

- Optimized for voltage source driving into 150 ohms •
- Enhanced Common Mode performance over UTP •
- Robust construction allows for solder reflow processes •
- Complies with or exceeds IEEE 802.5 Requirements •

### Electrical Parameters @ 25° C

Impedance ( $\Omega$ ) [Xmit/Rcv]	Insertion Loss (dB)								Return Loss (dB Min.)						Common Mode Rejection (dB Min.)						Crosstalk (dB Min.)				
	1-16 MHz		32 MHz		36 MHz		44 MHz		1-6 MHz		6-17 MHz		17-25 MHz		1-30 MHz		30-100 MHz		100-200 MHz			200-300 MHz		1-30 MHz	
Chip Side 150	Max.		Min.	Max.	Min.	Max.	Min.	Max.																	
Cable Side	Xmit	Rcv	Xmit	Rcv	Xmit	Rcv	Xmit	Rcv	Xmit	Rcv	Xmit	Rcv	Xmit	Rcv	Xmit	Rcv	Xmit	Rcv	Xmit	Rcv	Xmit	Rcv	Xmit	Rcv	
100	-8	-5	-7	-1	-25	-3	-30	-3	-18	-23	-12	-20	-8	-10	-50	-40	-35	-35	-30	-30	-20	-20			-38

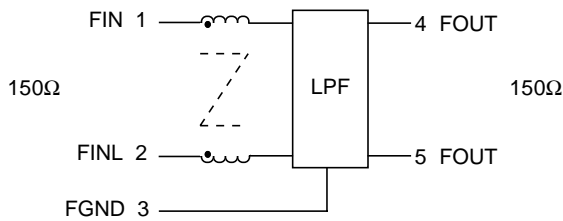

### Schematic

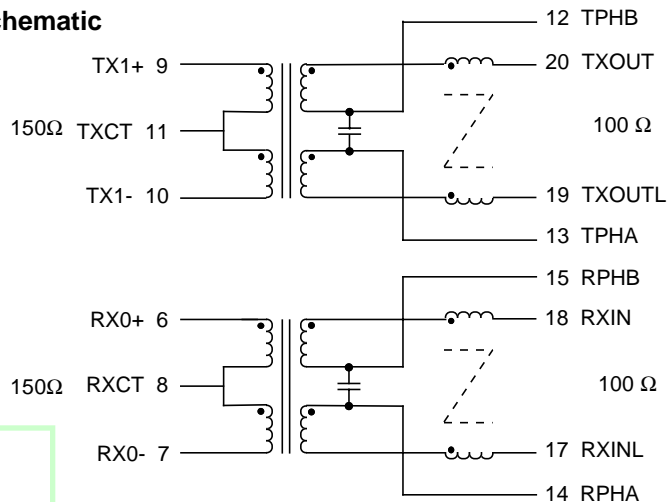

### Package

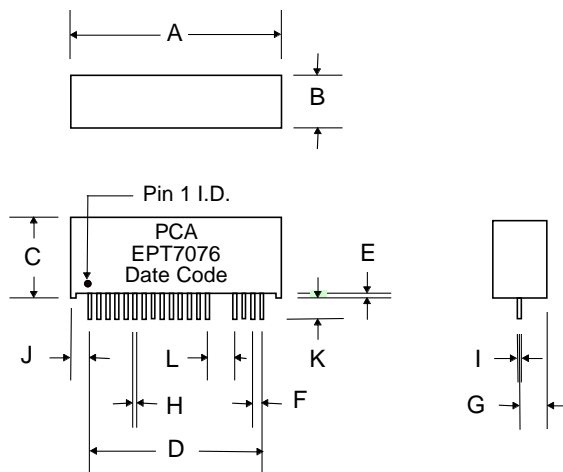

### Dimensions

Dim.	(Inches)			(Millimeters)		
	Min.	Max.	Nom.	Min.	Max.	Nom.
A	1.090	1.110		27.69	28.19	
B	.260	.280		6.60	7.11	
C	.380	.400		9.65	10.16	
D	.950	Typ.		24.13	Typ.	
E	.010	.030		.254	.762	
F	.050	Typ.		1.27	Typ.	
G	.135	Typ.		3.43	Typ.	
H	.016	.022		.406	.559	
I	.008	.012		.203	.305	
J	.075	Typ.		1.91	Typ.	
K	.130	.150		3.30	3.81	
L	.100	Typ.		2.54	Typ.	

The circuit below is a guideline for interconnecting PCA's EPT7076 with a typical Token Ring PHY chip for 4 Mb/16Mb applications over UTP cable. Further details of system design should be obtained from the specific chip manufacturer. Note that this module is optimized for a "voltage source" driver such as TI380C60.

Note that there is no need for the receiver side filtering. So consider this a cost effective solution for almost all Token Ring applications using this or similar chips.

The pull down resistors to chassis via a cap shown around the RJ45 connector have been known to suppress unwanted radiation that unused wires pick up from the immediate environment. This is specially true if driving UTP cable. Their placement and use are to be considered carefully before a design is finalized.

No specific recommendation is made here for phantom return circuitry: implementation varies. Please note that additional emission control has been observed if both nodes of the phantom bypass capacitor on the transmit channel are pulled to the chassis ground via suitable capacitors.

It is recommended that there be a neat separation of ground planes in the layout. It is generally accepted practice to limit the plane off at least 0.05 inches away from the chip side of EPT7076. There need not be any ground plane beyond this point.

For best results, PCB designer should design the outgoing traces preferably to be 50 ohms, balanced and well coupled to achieve minimum radiation from these traces.

### Typical Application Circuit Connection to TI380C60 (or Equivalent) For NIC.

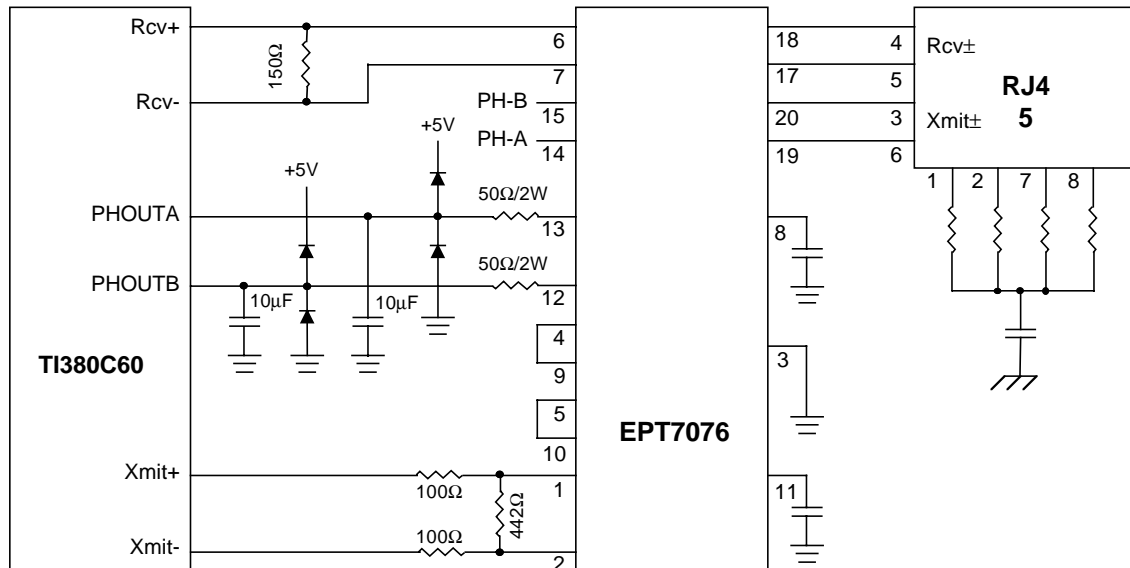

Notes : 1. Pins 15 & 14 are left unconnected. Applications vary. Your system may have a phantom drive return detection circuit needing pins 15 & 14 to be connected separately or together, can be taken to ground via an inductor.