

±15kV ESD Protected, Two Port, Dual Protocol Transceivers

The ISLX1334 are two port interface ICs where each port can be independently configured as a single RS-485/422 transceiver, or as a dual (2 Tx, 2 Rx) RS-232 transceiver. With both ports set to the same mode, two RS-485/422 transceivers, or four RS-232 transceivers are available.

If either port is in RS-232 mode, the onboard charge pump generates RS-232 compliant ±5V Tx output levels from a single V_{CC} supply as low as 4.5V. Four small 0.1µF capacitors are required for the charge pump. The transceivers are RS-232 compliant, with the Rx inputs handling up to ±25V, and the Tx outputs handling ±12V.

In RS-485 mode, the transceivers support both the RS-485 and RS-422 differential communication standards. The receivers feature "full failsafe" operation, so the Rx outputs remain in a high state if the inputs are open or shorted together. The transmitters support up to three data rates, two of which are slew rate limited for problem free communications. The charge pump disables when both ports are in RS-485 mode, thereby saving power, minimizing noise, and eliminating the charge pump capacitors.

Both RS-232 and RS-485 modes feature loopback and shutdown functions. Loopback internally connects the Tx outputs to the corresponding Rx input, to facilitate board level self test implementation. The outputs remain connected to the loads during loopback, so connection problems (e.g., shorted connectors or cables) can be detected. Shutdown mode disables the Tx and Rx outputs, disables the charge pumps, and places the IC in a low current (µA) mode.

The ISL41334 is a QFN packaged device that includes two additional user selectable, lower speed and edge rate options for EMI sensitive designs, or to allow longer bus lengths. It also features a logic supply pin (V_L) that sets the V_{OH} level of logic outputs, and the switching points of logic inputs, to be compatible with another supply voltage in mixed voltage systems. The QFN also adds active low Rx enable pins to increase design flexibility, allowing Tx/Rx direction control, via a single signal per port, by connecting the corresponding DE and RE pins together.

For a single port version of these devices, please see the ISL81387/ ISL41387 data sheet.

Features

- ±15kV (HBM) ESD Protected Bus Pins (RS-232 or RS-485)
- Two Independent Ports, Each User Selectable for RS-232 (2 Transceivers) or RS-485/422 (1 Transceiver)
- Flow-Through Pinouts Simplify Board Layouts
- Pb-Free Plus Anneal Available (RoHS Compliant)
- Large (2.7V) Differential V_{OUT} for Improved Noise Immunity in RS-485/422 Networks
- Full Failsafe (Open/Short) Rx in RS-485/422 Mode
- Loopback Mode Facilitates Board Self Test Functions
- User Selectable RS-485 Data Rates (ISL41334 Only)
 - Fast Speed 20Mbps
 - Slew Rate Limited. 460kbps
 - Slew Rate Limited. 115kbps
- Fast RS-232 Data Rate Up to 650kbps
- Low Current Shutdown Mode. 42µA
- QFN Package Saves Board Space (ISL41334 Only)
- Logic Supply Pin (V_L) Eases Operation in Mixed Supply Systems (ISL41334 Only)

Applications

- Gaming Applications (e.g., Slot Machines)
- Single Board Computers
- Factory Automation
- Security Networks
- Industrial/Process Control Networks
- Level Translators (e.g., RS-232 to RS-422)
- Point of Sale Equipment
- Dual Channel RS-485 Interfaces

TABLE 1. SUMMARY OF FEATURES

PART NUMBER	NO. OF PORTS	PACKAGE OPTIONS	RS-485 DATA RATE (bps)	RS-232 DATA RATE (kbps)	V _L PIN?	ACTIVE H or L Rx ENABLE?	LOW POWER SHUTDOWN?
ISL81334	2	28 Ld SOIC, 28 Ld SSOP	20M	650	NO	NONE	YES
ISL41334	2	40 Ld QFN (6 x 6mm)	20M, 460k, 115k	650	YES	L	YES

Ordering Information

PART NUMBER (NOTE)	PART MARKING	TEMP. RANGE (°C)	PACKAGE (Pb-Free)	PKG. DWG. #
ISL81334IAZ	81334IAZ	-40 to 85	28 Ld SSOP	M28.209
ISL81334IAZ-T	81334IAZ	-40 to 85	28 Ld SSOP Tape and Reel	M28.209
ISL81334IBZ	ISL81334IBZ	-40 to 85	28 Ld SOIC	M28.3
ISL81334IBZ-T	ISL81334IBZ	-40 to 85	28 Ld SOIC Tape and Reel	M28.3
ISL41334IRZ	41334IRZ	-40 to 85	40 Ld QFN	L40.6x6
ISL41334IRZ-T	41334IRZ	-40 to 85	40 Ld QFN Tape and Reel	L40.6x6

NOTE: Intersil Pb-free plus anneal products employ special Pb-free material sets; molding compounds/die attach materials and 100% matte tin plate termination finish, which are RoHS compliant and compatible with both SnPb and Pb-free soldering operations. Intersil Pb-free products are MSL classified at Pb-free peak reflow temperatures that meet or exceed the Pb-free requirements of IPC/JEDEC J STD-020.

Pinouts

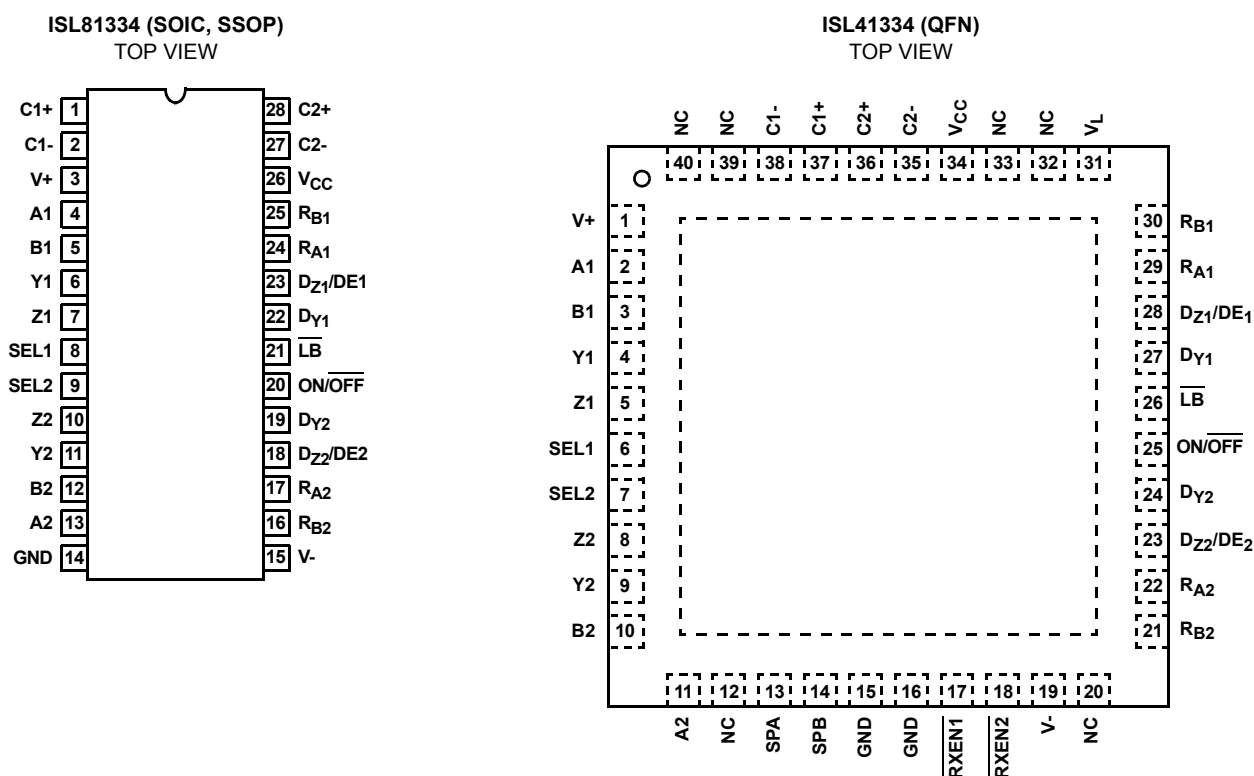

TABLE 2. ISL81334 FUNCTION TABLE

INPUTS			RECEIVER OUTPUTS		DRIVER OUTPUTS		CHARGE PUMPS (NOTE 1)	MODE
SEL1 or 2	ON/OFF	DE 1 or 2	R _A	R _B	Y	Z		
0	1	N.A.	ON	ON	ON	ON	ON	RS-232
X	0	X	High-Z	High-Z	High-Z	High-Z	OFF	Shutdown
1	1	0	ON	High-Z *	High-Z	High-Z	OFF	RS-485
1	1	1	ON	High-Z *	ON	ON	OFF	RS-485

NOTE:

- Charge pumps are off iff SEL1 = SEL2 = 1, or if ON/OFF = 0. If ON = 1, and either port is programmed for RS-232 mode, then the charge pumps are on.

ISL81334 Truth Tables (FOR EACH PORT)

RS-232 TRANSMITTING MODE					
INPUTS				OUTPUTS	
SEL1 or 2	ON/OFF	D _Y	D _Z	Y	Z
0	1	0	0	1	1
0	1	0	1	1	0
0	1	1	0	0	1
0	1	1	1	0	0
0	0	X	X	High-Z	High-Z

RS-485 TRANSMITTING MODE					
INPUTS				OUTPUTS	
SEL1 or 2	ON/OFF	DE1 or 2	D _Y	Y	Z
1	1	1	0	1	0
1	1	1	1	0	1
1	1	0	X	High-Z	High-Z
1	0	X	X	High-Z	High-Z

RS-232 RECEIVING MODE					
INPUTS				OUTPUT	
SEL1 or 2	ON/OFF	A	B	R _A	R _B
0	1	0	0	1	1
0	1	0	1	1	0
0	1	1	0	0	1
0	1	1	1	0	0
0	1	Open	Open	1	1
0	0	X	X	High-Z	High-Z

RS-485 RECEIVING MODE					
INPUTS				OUTPUT	
SEL1 or 2	ON/OFF	B-A		R _A	R _B *
1	1	≥ -40mV		1	High-Z
1	1	≤ -200mV		0	High-Z
1	1	Open or Shorted together		1	High-Z
1	0	X		High-Z	High-Z

* Internally pulled high through a 40kΩ resistor.

TABLE 3. ISL41334 FUNCTION TABLE

INPUTS						RECEIVER OUTPUTS		DRIVER OUTPUTS		CHARGE PUMPS (NOTE 2)	DRIVER DATA RATE (Mbps)	MODE
SEL1 or 2	ON/OFF	SPA	SPB	RXEN 1 or 2	DE 1 or 2	R _A	R _B	Y	Z			
0	1	X	X	0	N.A.	ON	ON	ON	ON	ON	0.46	RS-232
0	1	X	X	1	N.A.	High-Z	High-Z	ON	ON	ON	0.46	RS-232
X	0	X	X	X	X	High-Z	High-Z	High-Z	High-Z	OFF	N.A.	Shutdown
1	1	X	X	0	0	ON	High-Z *	High-Z	High-Z	OFF	N.A.	RS-485
1	1	0	0	0	1	ON	High-Z *	ON	ON	OFF	0.46	RS-485
1	1	0	1	0	1	ON	High-Z *	ON	ON	OFF	0.115	RS-485
1	1	1	0	0	1	ON	High-Z *	ON	ON	OFF	20	RS-485
1	1	1	1	0	1	ON	High-Z *	ON	ON	OFF	20	RS-485
1	1	X	X	1	0	High-Z	High-Z *	High-Z	High-Z	OFF	N.A.	RS-485
1	1	0	0	1	1	High-Z	High-Z *	ON	ON	OFF	0.46	RS-485
1	1	0	1	1	1	High-Z	High-Z *	ON	ON	OFF	0.115	RS-485
1	1	1	0	1	1	High-Z	High-Z *	ON	ON	OFF	20	RS-485
1	1	1	1	1	1	High-Z	High-Z *	ON	ON	OFF	20	RS-485

NOTE:

- Charge pumps are off iff SEL1 = SEL2 = 1, or if ON/OFF = 0. If ON = 1, and either port is programmed for RS-232 mode, then the charge pumps are on.

ISL41334 Truth Tables (FOR EACH PORT)

RS-232 TRANSMITTING MODE					
INPUTS			OUTPUTS		
SEL1 or 2	ON/OFF	D _Y	D _Z	Y	Z
0	1	0	0	1	1
0	1	0	1	1	0
0	1	1	0	0	1
0	1	1	1	0	0
0	0	X	X	High-Z	High-Z

RS-232 RECEIVING MODE						
INPUTS					OUTPUT	
SEL1 or 2	ON/OFF	RXEN 1 or 2	A	B	R _A	R _B
0	1	0	0	0	1	1
0	1	0	0	1	1	0
0	1	0	1	0	0	1
0	1	0	1	1	0	0
0	1	0	Open	Open	1	1
0	1	1	X	X	High-Z	High-Z
0	0	X	X	X	High-Z	High-Z

RS-485 TRANSMITTING MODE								
INPUTS						OUTPUTS		DATA RATE
SEL1 or 2	ON/OFF	DEN 1 or 2	SPA	SPB	D _Y	Y	Z	Mbps
1	1	1	0	0	0/1	1/0	0/1	0.46
1	1	1	0	1	0/1	1/0	0/1	0.115
1	1	1	1	X	0/1	1/0	0/1	20
1	1	0	X	X	X	High-Z	High-Z	N.A.
1	0	X	X	X	X	High-Z	High-Z	N.A.

RS-485 RECEIVING MODE					
INPUTS				OUTPUT	
SEL1 or 2	ON/OFF	RXEN 1 or 2	B-A	R _A	R _B *
1	1	0	≥ -40mV	1	High-Z
1	1	0	≤ -200mV	0	High-Z
1	1	0	Open or Shorted together	1	High-Z
1	1	1	X	High-Z	High-Z
1	0	X	X	High-Z	High-Z

* Internally pulled high through a 40kΩ resistor.

Pin Descriptions

PIN	MODE	FUNCTION
GND	BOTH	Ground connection.
$\overline{\text{LB}}$	BOTH	Enables loopback mode when low. Internally pulled-high.
NC	BOTH	No Connection.
$\overline{\text{ON/OFF}}$	BOTH	If either port is in RS-232 mode, a low on $\overline{\text{ON/OFF}}$ disables the charge pumps. In either mode, a low disables all the outputs, and places the device in low power shutdown. Internally pulled-high. ON = 1 for normal operation.
$\overline{\text{RXEN}}$	BOTH	Active low receiver output enable. Rx is enabled when $\overline{\text{RXEN}}$ is low; Rx is high impedance when $\overline{\text{RXEN}}$ is high. Internally pulled low. (QFN only)
SEL	BOTH	Interface Mode Select input. High puts corresponding port in RS-485 Mode, while a low puts it in RS-232 Mode.
V _{CC}	BOTH	System power supply input (5V).
V _L	BOTH	Logic-Level Supply. All TTL/CMOS inputs and outputs are powered by this supply. (QFN only)
A	RS-232	Receiver input with ±15kV ESD protection. A low on A forces R _A high; A high on A forces R _A low.
	RS-485	Inverting receiver input with ±15kV ESD protection.
B	RS-232	Receiver input with ±15kV ESD protection. A low on B forces R _B high; A high on B forces R _B low.
	RS-485	Noninverting receiver input with ±15kV ESD protection.
D _Y	RS-232	Driver input. A low on D _Y forces output Y high. Similarly, a high on D _Y forces output Y low.
	RS-485	Driver input. A low on D _Y forces output Y high and output Z low. Similarly, a high on D _Y forces output Y low and output Z high.
D _Z	RS-232	Driver input. A low on D _Z forces output Z high. Similarly, a high on D _Z forces output Z low.
DE	RS-485	Driver output enable. The driver outputs, Y and Z, are enabled by bringing DE high. They are high impedance when DE is low. Internally pulled high when port selected for RS-485 mode.
R _A	RS-232	Receiver output.
	RS-485	Receiver output: If B > A by at least -40mV, R _A is high; If B < A by -200mV or more, R _A is low; R _A = High if A and B are unconnected (floating) or shorted together (i.e., full fail-safe).
R _B	RS-232	Receiver output.
	RS-485	Not used. Internally pulled-high, and unaffected by $\overline{\text{RXEN}}$.
Y	RS-232	Driver output with ±15kV ESD protection.
	RS-485	Inverting driver output with ±15kV ESD protection.
Z	RS-232	Driver output with ±15kV ESD protection.
	RS-485	Noninverting driver output with ±15kV ESD protection.
SP	RS-485	Speed control. Internally pulled-high. (QFN only)
C1+	RS-232	External capacitor (voltage doubler) is connected to this lead. Not needed if both ports in RS-485 Mode.
C1-	RS-232	External capacitor (voltage doubler) is connected to this lead. Not needed if both ports in RS-485 Mode.
C2+	RS-232	External capacitor (voltage inverter) is connected to this lead. Not needed if both ports in RS-485 Mode.
C2-	RS-232	External capacitor (voltage inverter) is connected to this lead. Not needed if both ports in RS-485 Mode.
V+	RS-232	Internally generated positive RS-232 transmitter supply (+5.5V). C3 not needed if both ports in RS-485 Mode.
V-	RS-232	Internally generated negative RS-232 transmitter supply (-5.5V). C4 not needed if both ports in RS-485 Mode.

Typical Operating Circuit

RS-232 MODE WITHOUT LOOPBACK

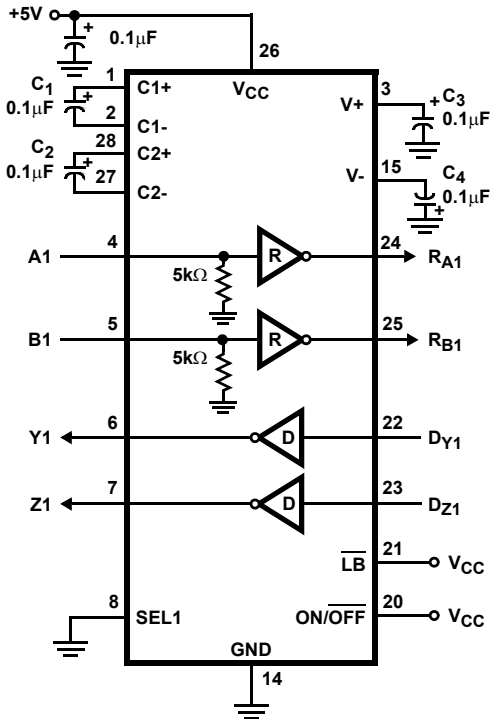

NOTE: PINOUT FOR SOIC AND SSOP SAME FOR PORT 2.

RS-232 MODE WITH LOOPBACK

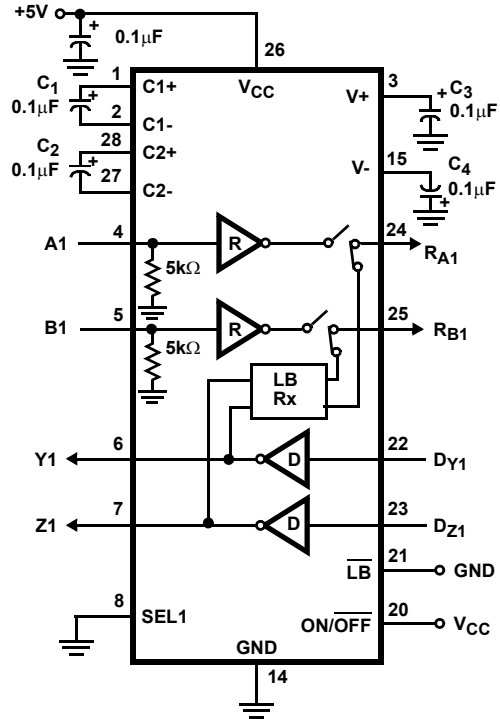

NOTE: PINOUT FOR SOIC AND SSOP SAME FOR PORT 2.

RS-485 MODE WITHOUT LOOPBACK

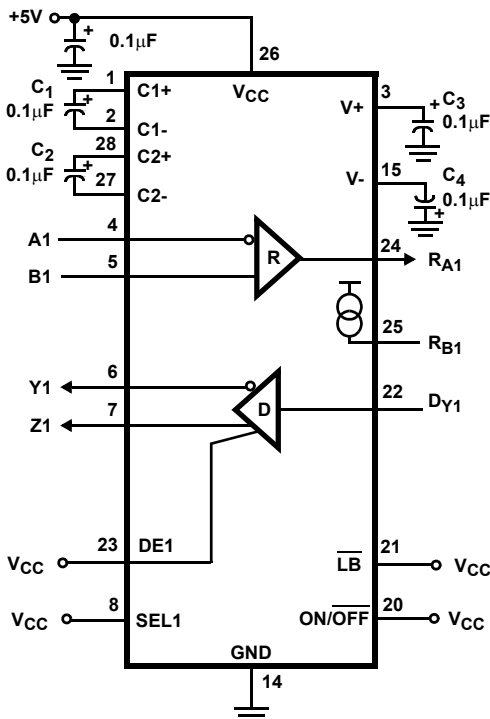

NOTE: PINOUT FOR SOIC AND SSOP SAME FOR PORT 2.

RS-485 MODE WITH LOOPBACK

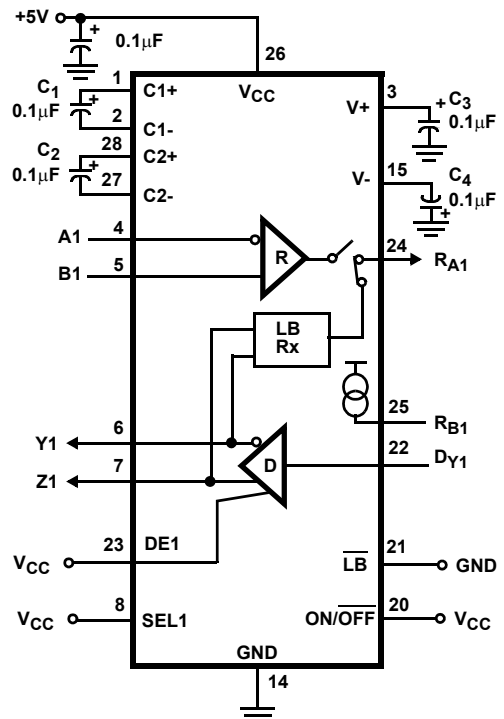

NOTE: PINOUT FOR SOIC AND SSOP SAME FOR PORT 2.

Absolute Maximum Ratings (T_A = 25°C)

V _{CC} to Ground	7V
V _L (QFN Only)	-0.5V to V _{CC} + 0.5V
Input Voltages	
All Except A, B (non-QFN Package)	-0.5V to (V _{CC} + 0.5V)
All Except A, B (QFN Package)	-0.5V to (V _L + 0.5V)
Input/Output Voltages	
A, B (Any Mode)	-25V to +25V
Y, Z (Any Mode, Note 3)	-12.5V to +12.5V
R _A , R _B (non-QFN Package)	-0.5V to (V _{CC} + 0.5V)
R _A , R _B (QFN Package)	-0.5V to (V _L + 0.5V)
Output Short Circuit Duration	
Y, Z, R _A , R _B	Indefinite
ESD Rating	See Specification Table

Thermal Information

Thermal Resistance (Typical, Note 4)	θ _{JA} (°C/W)
28 Ld SOIC Package	65
28 Ld SSOP Package	60
40 Ld QFN Package	32
Maximum Junction Temperature (Plastic Package)	150°C
Maximum Storage Temperature Range	-65°C to 150°C
Maximum Lead Temperature (Soldering 10s)	300°C (SOIC and SSOP - Lead Tips Only)

Operating Conditions

Temperature Range	-40°C to 85°C
-------------------	---------------

CAUTION: Stresses above those listed in "Absolute Maximum Ratings" may cause permanent damage to the device. This is a stress only rating and operation of the device at these or any other conditions above those indicated in the operational sections of this specification is not implied.

NOTES:

- One output at a time, I_{OUT} ≤ 100mA for ≤ 10 mins.
- QFN θ_{JA} is measured in free air with the component mounted on a high effective thermal conductivity test board with "direct attach" features. θ_{JA} for other packages is measured with the component mounted on a high effective thermal conductivity test board in free air. See Tech Brief TB379 and Tech Brief TB389 for details.

Electrical Specifications Test Conditions: V_{CC} = 4.5V to 5.5V, C1 - C4 = 0.1μF, V_L = V_{CC} (for QFN only); Unless Otherwise Specified. Typical values are at V_{CC} = 5V, T_A = 25°C (Note 5)

PARAMETER	SYMBOL	TEST CONDITIONS	TEMP (°C)	MIN	TYP	MAX	UNITS	
DC CHARACTERISTICS - RS-485 DRIVER (SEL = V_{CC})								
Driver Differential V _{OUT} (no load)	V _{OD1}		Full	-	-	V _{CC}	V	
Driver Differential V _{OUT} (with load)	V _{OD2}	R = 50Ω (RS-422) (Figure 1)	Full	2.5	3.1	-	V	
		R = 27Ω (RS-485) (Figure 1)	Full	2.2	2.7	5	V	
	V _{OD3}	R _D = 60Ω, R = 375Ω, V _{CM} = -7V to 12V (Figure 1)	Full	2	2.7	5	V	
Change in Magnitude of Driver Differential V _{OUT} for Complementary Output States	ΔV _{OD}	R = 27Ω or 50Ω (Figure 1)	Full	-	0.01	0.2	V	
Driver Common-Mode V _{OUT}	V _{OC}	R = 27Ω or 50Ω (Figure 1) (Note 9)	Full	-	-	3.1	V	
Change in Magnitude of Driver Common-Mode V _{OUT} for Complementary Output States	ΔV _{OC}	R = 27Ω or 50Ω (Figure 1) (Note 9)	Full	-	0.01	0.2	V	
Driver Short-Circuit Current, V _{OUT} = High or Low	I _{OS}	-7V ≤ (V _Y or V _Z) ≤ 12V (Note 7)	Full	35	-	250	mA	
Driver Three-State Output Leakage Current (Y, Z)	I _{OZ}	Outputs Disabled, V _{CC} = 0V or 5.5V	V _{OUT} = 12V	Full	-	-	500	μA
			V _{OUT} = -7V	Full	-200	-	-	μA
DC CHARACTERISTICS - RS-232 DRIVER (SEL = GND)								
Driver Output Voltage Swing	V _O	All T _{OUTS} Loaded with 3kΩ to Ground	Full	±5.0	+6/-7	-	V	
Driver Output Short-Circuit Current	I _{OS}	V _{OUT} = 0V	Full	-60	25/-35	60	mA	
DC CHARACTERISTICS - LOGIC PINS (i.e., DRIVER AND CONTROL INPUT PINS)								
Input High Voltage	V _{IH1}	V _L = V _{CC} if QFN	Full	2	1.6	-	V	
	V _{IH2}	V _L = 3.3V (QFN Only)	Full	2	1.2	-	V	
	V _{IH3}	V _L = 2.5V (QFN Only)	Full	1.5	1	-	V	

ISL81334, ISL41334

Electrical Specifications Test Conditions: $V_{CC} = 4.5V$ to $5.5V$, $C1 - C4 = 0.1\mu F$, $V_L = V_{CC}$ (for QFN only); Unless Otherwise Specified. Typical values are at $V_{CC} = 5V$, $T_A = 25^\circ C$ (Note 5) **(Continued)**

PARAMETER	SYMBOL	TEST CONDITIONS	TEMP (°C)	MIN	TYP	MAX	UNITS	
Input Low Voltage	V_{IL1}	$V_L = V_{CC}$ if QFN	Full	-	1.4	0.8	V	
	V_{IL2}	$V_L = 3.3V$ (QFN Only)	Full	-	1	0.7	V	
	V_{IL3}	$V_L = 2.5V$ (QFN Only)	Full	-	-	0.5	V	
Input Current	I_{IN1}	Pins Without Pull-ups or Pull-downs	Full	-2	-	2	μA	
	I_{IN2}	\overline{LB} , ON/\overline{OFF} , DE , SP (QFN), \overline{RXEN} (QFN)	Full	-25	-	25	μA	
DC CHARACTERISTICS - RS-485 RECEIVER INPUTS (SEL = V_{CC})								
Receiver Differential Threshold Voltage	V_{TH}	$-7V \leq V_{CM} \leq 12V$, Full Failsafe	Full	-0.2	-	-0.04	V	
Receiver Input Hysteresis	ΔV_{TH}	$V_{CM} = 0V$	25	-	35	-	mV	
Receiver Input Current (A, B)	I_{IN}	$V_{CC} = 0V$ or 4.5 to $5.5V$	$V_{IN} = 12V$	Full	-	-	0.8	mA
			$V_{IN} = -7V$	Full	-0.64	-	-	mA
Receiver Input Resistance	R_{IN}	$-7V \leq V_{CM} \leq 12V$, $V_{CC} = 0$ (Note 8) or $4.5V \leq V_{CC} \leq 5.5V$	Full	15	-	-	k Ω	
DC CHARACTERISTICS - RS-232 RECEIVER INPUTS (SEL = GND)								
Receiver Input Voltage Range	V_{IN}		Full	-25	-	25	V	
Receiver Input Threshold	V_{IL}		Full	-	1.4	0.8	V	
	V_{IH}		Full	2.4	1.9	-	V	
Receiver Input Hysteresis	ΔV_{TH}		25	-	0.5	-	V	
Receiver Input Resistance	R_{IN}	$V_{IN} = \pm 15V$, V_{CC} Powered Up (Note 8)	Full	3	5	7	k Ω	
DC CHARACTERISTICS - RECEIVER OUTPUTS (485 OR 232 MODE)								
Receiver Output High Voltage	V_{OH1}	$I_O = -2mA$ ($V_L = V_{CC}$ if QFN)	Full	3.5	4.6	-	V	
	V_{OH2}	$I_O = -650\mu A$, $V_L = 3V$, QFN Only	Full	2.6	2.9	-	V	
	V_{OH3}	$I_O = -500\mu A$, $V_L = 2.5V$, QFN Only	Full	2	2.4	-	V	
Receiver Output Low Voltage	V_{OL}	$I_O = 3mA$	Full	-	0.1	0.4	V	
Receiver Short-Circuit Current	I_{OSR}	$0V \leq V_O \leq V_{CC}$	Full	7	-	85	mA	
Receiver Three-State Output Current	I_{OZR}	Output Disabled, $0V \leq V_O \leq V_{CC}$ (or V_L for QFN)	Full	-	-	± 10	μA	
Unused Receiver (R_B) Pull-Up Resistance	R_{OBZ}	$ON/\overline{OFF} = V_{CC}$, $SELX = V_{CC}$ (RS-485 Mode)	25	-	40	-	k Ω	
POWER SUPPLY CHARACTERISTICS								
No-Load Supply Current, Note 6	I_{CC232}	$SEL1$ or $SEL2 = GND$, $\overline{LB} = ON/\overline{OFF} = V_{CC}$	Full	-	3.7	7	mA	
	I_{CC485}	$SEL 1 \& 2 = \overline{LB} = DE = ON/\overline{OFF} = V_{CC}$	Full	-	1.6	5	mA	
Shutdown Supply Current	$I_{SHDN232}$	$ON/\overline{OFF} = SELX = GND$, $\overline{LB} = V_{CC}$, ($SPX = V_{CC}$ if QFN)	Full	-	25	50	μA	
	$I_{SHDN485}$	$ON/\overline{OFF} = DEX = GND$, $SELX = \overline{LB} = V_{CC}$, ($SPX = GND$ if QFN)	SOIC/SSOP	Full	-	42	80	μA
QFN			Full	-	80	160	μA	
ESD CHARACTERISTICS								
Bus Pins (A, B, Y, Z) Any Mode		Human Body Model	25	-	15	-	kV	
All Other Pins		Human Body Model	25	-	4	-	kV	

ISL81334, ISL41334

Electrical Specifications Test Conditions: $V_{CC} = 4.5V$ to $5.5V$, $C_1 - C_4 = 0.1\mu F$, $V_L = V_{CC}$ (for QFN only); Unless Otherwise Specified. Typicals are at $V_{CC} = 5V$, $T_A = 25^\circ C$ (Note 5) (Continued)

PARAMETER	SYMBOL	TEST CONDITIONS	TEMP (°C)	MIN	TYP	MAX	UNITS	
RS-232 DRIVER AND RECEIVER SWITCHING CHARACTERISTICS (SEL = GND, ALL VERSIONS AND SPEEDS)								
Driver Output Transition Region Slew Rate	SR	$R_L = 3k\Omega$, Measured From 3V to -3V or -3V to 3V	$C_L \geq 15pF$	Full	-	18	30	V/ μs
			$C_L \leq 2500pF$	Full	4	12	-	V/ μs
Driver Output Transition Time	t_r, t_f	$R_L = 3k\Omega$, $C_L = 2500pF$, 10% - 90%	Full	0.22	1.2	3.1	μs	
Driver Propagation Delay	t_{DPHL}	$R_L = 3k\Omega$, $C_L = 1000pF$ (Figure 6)	Full	-	1	2	μs	
	t_{DPLH}		Full	-	1.2	2	μs	
Driver Propagation Delay Skew	t_{DSKEW}	$t_{DPHL} - t_{DPLH}$ (Figure 6)	Full	-	240	400	ns	
Driver Enable Time from Shutdown	t_{DENSD}	$V_{OUT} = \pm 3.0V$	25	-	20	-	μs	
Driver Maximum Data Rate	DR_D	$R_L = 3k\Omega$, $C_L = 1000pF$, One Transmitter Switching per port	Full	460	650	-	kbps	
Receiver Propagation Delay	t_{RPHL}	$C_L = 15pF$ (Figure 7)	Full	-	50	120	ns	
	t_{RPLH}		Full	-	40	120	ns	
Receiver Propagation Delay Skew	t_{RSKEW}	$t_{RPHL} - t_{RPLH}$ (Figure 7)	Full	-	10	40	ns	
Receiver Maximum Data Rate	DR_R	$C_L = 15pF$	Full	0.46	2	-	Mbps	
RS-485 DRIVER SWITCHING CHARACTERISTICS (FAST DATA RATE (20Mbps), SEL = V_{CC}, ALL VERSIONS (SPA = V_{CC} if QFN))								
Driver Differential Input to Output Delay	t_{DLH}, t_{DHL}	$R_{DIFF} = 54\Omega$, $C_L = 100pF$ (Figure 2)	Full	15	30	50	ns	
Driver Output Skew	t_{SKEW}	$R_{DIFF} = 54\Omega$, $C_L = 100pF$ (Figure 2)	Full	-	0.5	10	ns	
Driver Differential Rise or Fall Time	t_R, t_F	$R_{DIFF} = 54\Omega$, $C_L = 100pF$, Figure 2	Full	3	11	20	ns	
Driver Enable to Output Low	t_{ZL}	$C_L = 100pF$, SW = V_{CC} (Figure 3)	Full	-	27	60	ns	
Driver Enable to Output High	t_{ZH}	$C_L = 100pF$, SW = GND (Figure 3)	Full	-	24	60	ns	
Driver Disable from Output Low	t_{LZ}	$C_L = 15pF$, SW = V_{CC} (Figure 3)	Full	-	31	60	ns	
Driver Disable from Output High	t_{HZ}	$C_L = 15pF$, SW = GND (Figure 3)	Full	-	24	60	ns	
Driver Enable from Shutdown to Output Low	$t_{ZL(SHDN)}$	$R_L = 500\Omega$, $C_L = 100pF$, SW = V_{CC} (Figure 3)	Full	-	65	250	ns	
Driver Enable from Shutdown to Output High	$t_{ZH(SHDN)}$	$R_L = 500\Omega$, $C_L = 100pF$, SW = GND (Figure 3)	Full	-	152	250	ns	
Driver Maximum Data Rate	f_{MAX}	$R_{DIFF} = 54\Omega$, $C_L = 100pF$ (Figure 2)	Full	-	30	-	Mbps	
RS-485 DRIVER SWITCHING CHARACTERISTICS (MEDIUM DATA RATE (460kbps, QFN ONLY), SEL = V_{CC}, SPA = SPB= GND)								
Driver Differential Input to Output Delay	t_{DLH}, t_{DHL}	$R_{DIFF} = 54\Omega$, $C_L = 100pF$ (Figure 2)	Full	200	490	1000	ns	
Driver Output Skew	t_{SKEW}	$R_{DIFF} = 54\Omega$, $C_L = 100pF$ (Figure 2)	Full	-	110	400	ns	
Driver Differential Rise or Fall Time	t_R, t_F	$R_{DIFF} = 54\Omega$, $C_L = 100pF$ (Figure 2)	Full	300	600	1100	ns	
Driver Enable to Output Low	t_{ZL}	$C_L = 100pF$, SW = V_{CC} (Figure 3)	Full	-	30	300	ns	
Driver Enable to Output High	t_{ZH}	$C_L = 100pF$, SW = GND (Figure 3)	Full	-	128	300	ns	
Driver Disable from Output Low	t_{LZ}	$C_L = 15pF$, SW = V_{CC} (Figure 3)	Full	-	31	60	ns	
Driver Disable from Output High	t_{HZ}	$C_L = 15pF$, SW = GND (Figure 3)	Full	-	24	60	ns	
Driver Enable from Shutdown to Output Low	$t_{ZL(SHDN)}$	$R_L = 500\Omega$, $C_L = 100pF$, SW = V_{CC} (Figure 3)	Full	-	65	500	ns	
Driver Enable from Shutdown to Output High	$t_{ZH(SHDN)}$	$R_L = 500\Omega$, $C_L = 100pF$, SW = GND (Figure 3)	Full	-	255	500	ns	

ISL81334, ISL41334

Electrical Specifications Test Conditions: $V_{CC} = 4.5V$ to $5.5V$, $C_1 - C_4 = 0.1\mu F$, $V_L = V_{CC}$ (for QFN only); Unless Otherwise Specified. Typical values are at $V_{CC} = 5V$, $T_A = 25^\circ C$ (Note 5) **(Continued)**

PARAMETER	SYMBOL	TEST CONDITIONS	TEMP (°C)	MIN	TYP	MAX	UNITS	
Driver Maximum Data Rate	f_{MAX}	$R_{DIFF} = 54\Omega$, $C_L = 100pF$ (Figure 2)	Full	-	2000	-	kbps	
RS-485 DRIVER SWITCHING CHARACTERISTICS (SLOW DATA RATE (115kbps, QFN ONLY), SEL = V_{CC}, SPA = GND, SPB = V_{CC})								
Driver Differential Input to Output Delay	t_{DLH} , t_{DHL}	$R_{DIFF} = 54\Omega$, $C_L = 100pF$ (Figure 2)	Full	800	1500	2500	ns	
Driver Output Skew	t_{SKEW}	$R_{DIFF} = 54\Omega$, $C_L = 100pF$ (Figure 2)	Full	-	350	1250	ns	
Driver Differential Rise or Fall Time	t_R , t_F	$R_{DIFF} = 54\Omega$, $C_L = 100pF$ (Figure 2)	Full	1000	2000	3100	ns	
Driver Enable to Output Low	t_{ZL}	$C_L = 100pF$, SW = V_{CC} (Figure 3)	Full	-	32	600	ns	
Driver Enable to Output High	t_{ZH}	$C_L = 100pF$, SW = GND (Figure 3)	Full	-	300	600	ns	
Driver Disable from Output Low	t_{LZ}	$C_L = 15pF$, SW = V_{CC} (Figure 3)	Full	-	31	60	ns	
Driver Disable from Output High	t_{HZ}	$C_L = 15pF$, SW = GND (Figure 3)	Full	-	24	60	ns	
Driver Enable from Shutdown to Output Low	$t_{ZL(SHDN)}$	$R_L = 500\Omega$, $C_L = 100pF$, SW = V_{CC} (Figure 3)	Full	-	65	800	ns	
Driver Enable from Shutdown to Output High	$t_{ZH(SHDN)}$	$R_L = 500\Omega$, $C_L = 100pF$, SW = GND (Figure 3)	Full	-	420	800	ns	
Driver Maximum Data Rate	f_{MAX}	$R_{DIFF} = 54\Omega$, $C_L = 100pF$ (Figure 2)	Full	-	800	-	kbps	
RS-485 RECEIVER SWITCHING CHARACTERISTICS (SEL = V_{CC}, ALL VERSIONS AND SPEEDS)								
Receiver Input to Output Delay	t_{PLH} , t_{PHL}	(Figure 4)	Full	20	50	90	ns	
Receiver Skew $t_{PLH} - t_{PHL}$	t_{SKEW}	(Figure 4)	Full	-	0.1	10	ns	
Receiver Maximum Data Rate	f_{MAX}		Full	-	40	-	Mbps	
RECEIVER ENABLE/DISABLE CHARACTERISTICS (ALL MODES AND SPEEDS)								
Receiver Enable to Output Low	t_{ZL}	QFN Only, $C_L = 15pF$, SW = V_{CC} (Figure 5)	Full	-	22	60	ns	
Receiver Enable to Output High	t_{ZH}	QFN Only, $C_L = 15pF$, SW = GND (Figure 5)	Full	-	23	60	ns	
Receiver Disable from Output Low	t_{LZ}	QFN Only, $C_L = 15pF$, SW = V_{CC} (Figure 5)	Full	-	24	60	ns	
Receiver Disable from Output High	t_{HZ}	QFN Only, $C_L = 15pF$, SW = GND (Figure 5)	Full	-	25	60	ns	
Receiver Enable from Shutdown to Output Low	t_{ZLSHDN}	$C_L = 15pF$, SW = V_{CC} (Figure 5)	RS-485 Mode	Full	-	260	700	ns
			RS-232 Mode	25	-	35	-	ns
Receiver Enable from Shutdown to Output High	t_{ZHSHDN}	$C_L = 15pF$, SW = GND (Figure 5)	RS-485 Mode	Full	-	260	700	ns
			RS-232 Mode	25	-	25	-	ns

NOTES:

5. All currents into device pins are positive; all currents out of device pins are negative. All voltages are referenced to device ground unless otherwise specified.
6. Supply current specification is valid for loaded drivers when DE = 0V (RS-485 mode only).
7. Applies to peak current. See "Typical Performance Curves" for more information.
8. R_{IN} defaults to RS-485 mode ($>15k\Omega$) when the device is unpowered ($V_{CC} = 0V$), regardless of the state of the SEL inputs.
9. $V_{CC} \leq 5.25V$.

Test Circuits and Waveforms

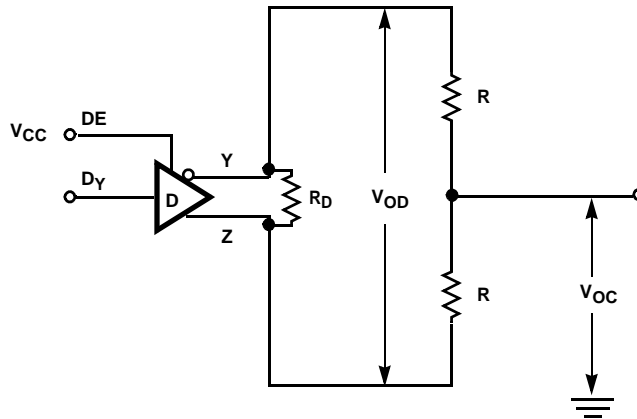

FIGURE 1. RS-485 DRIVER V_{OD} AND V_{OC} TEST CIRCUIT

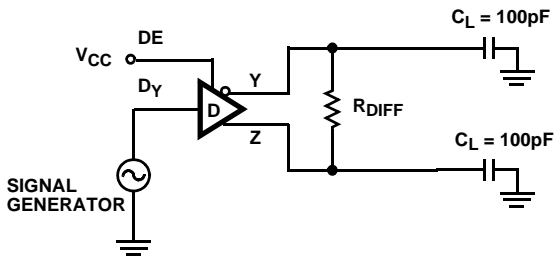
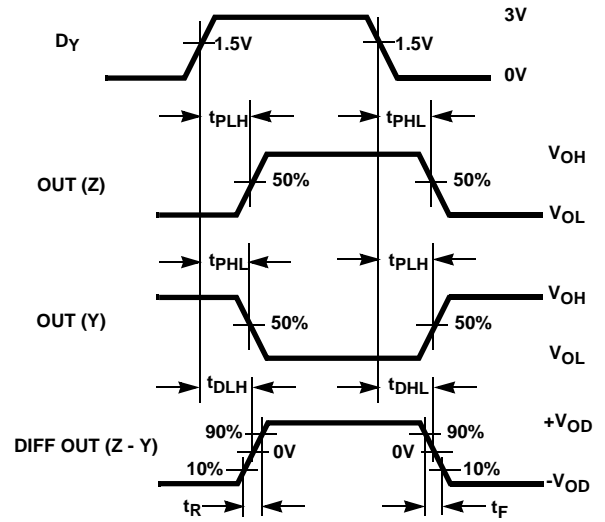

FIGURE 2A. TEST CIRCUIT



$$\text{SKEW} = |t_{PLH}(Y \text{ or } Z) - t_{PHL}(Z \text{ or } Y)|$$

FIGURE 2B. MEASUREMENT POINTS

FIGURE 2. RS-485 DRIVER PROPAGATION DELAY AND DIFFERENTIAL TRANSITION TIMES

Test Circuits and Waveforms (Continued)

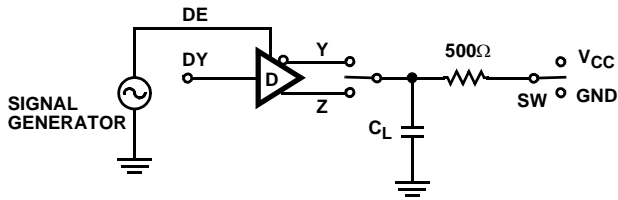

FOR SHDN TESTS, SWITCH ON/OFF RATHER THAN DE

PARAMETER	ON/DE	OUTPUT	DY	SW	CL (pF)
t _{HZ}	1/-	Y/Z	0/1	GND	15
t _{LZ}	1/-	Y/Z	1/0	V _{CC}	15
t _{ZH}	1/-	Y/Z	0/1	GND	100
t _{ZL}	1/-	Y/Z	1/0	V _{CC}	100
t _{ZH(SHDN)}	-/1	Y/Z	0/1	GND	100
t _{ZL(SHDN)}	-/1	Y/Z	1/0	V _{CC}	100

FIGURE 3A. TEST CIRCUIT

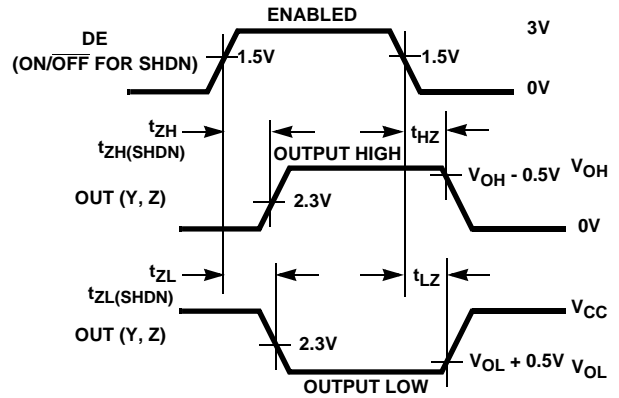

FIGURE 3B. MEASUREMENT POINTS

FIGURE 3. RS-485 DRIVER ENABLE AND DISABLE TIMES

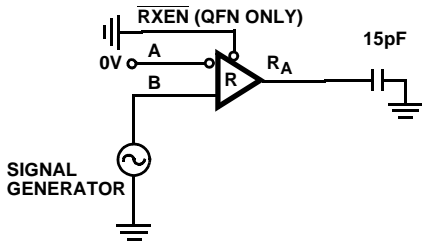

FIGURE 4A. TEST CIRCUIT

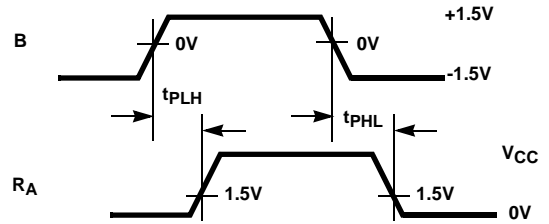
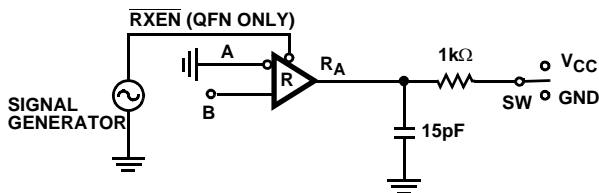

FIGURE 4B. MEASUREMENT POINTS

FIGURE 4. RS-485 RECEIVER PROPAGATION DELAY



FOR SHDN TESTS, SWITCH ON/OFF RATHER THAN RXEN

PARAMETER	ON/RXEN	B	SW
t _{HZ} (QFN Only)	1/-	+1.5V	GND
t _{LZ} (QFN Only)	1/-	-1.5V	V _{CC}
t _{ZH} (QFN Only)	1/-	+1.5V	GND
t _{ZL} (QFN Only)	1/-	-1.5V	V _{CC}
t _{ZH(SHDN)}	-/0	+1.5V	GND
t _{ZL(SHDN)}	-/0	-1.5V	V _{CC}

FIGURE 5A. TEST CIRCUIT

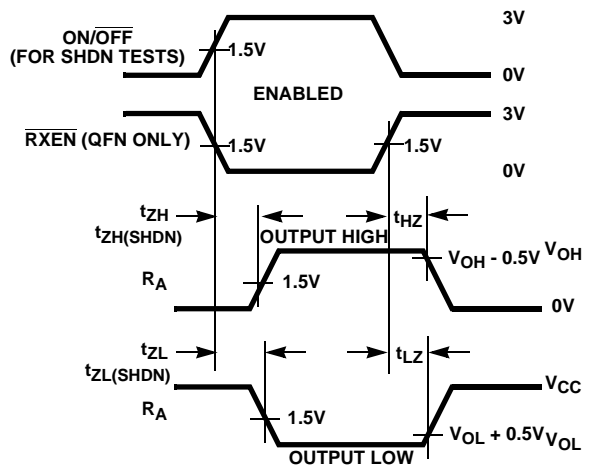

FIGURE 5B. MEASUREMENT POINTS

FIGURE 5. RS-485 RECEIVER ENABLE AND DISABLE TIMES

Test Circuits and Waveforms (Continued)

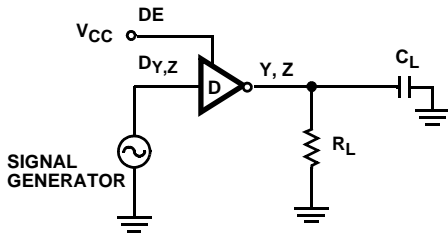

FIGURE 6A. TEST CIRCUIT

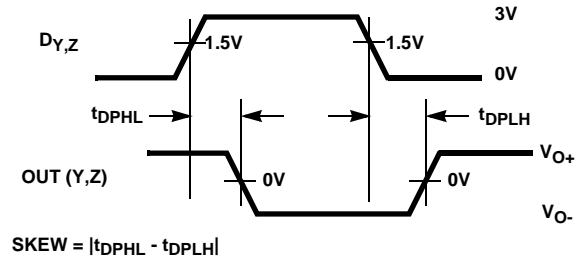

FIGURE 6B. MEASUREMENT POINTS

FIGURE 6. RS-232 DRIVER PROPAGATION DELAY AND TRANSITION TIMES

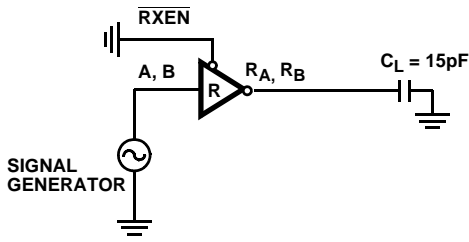

FIGURE 7A. TEST CIRCUIT

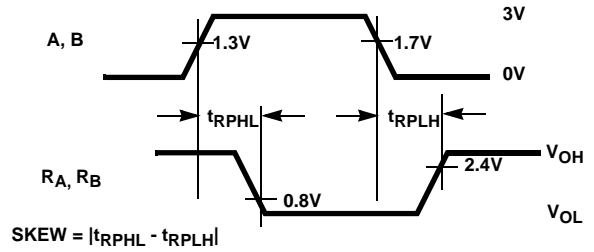

FIGURE 7B. MEASUREMENT POINTS

FIGURE 7. RS-232 RECEIVER PROPAGATION DELAY AND TRANSITION TIMES

Typical Application

RS-232 to RS-485 Converter

The ISLX1334 are ideal for implementing a single IC 2-wire (Tx Data, Rx Data) protocol converter, because each port can be programmed for a different protocol. Figure 8 illustrates the simple connections to create a single transceiver RS-232 to RS-485 converter. Depending on the RS-232 data rate, using an RS-422 bus as an RS-232 “extension cord” can extend the transmission distance up to 4000’ (1220m). A similar circuit on the other end of the cable completes the conversion to/from RS-232.

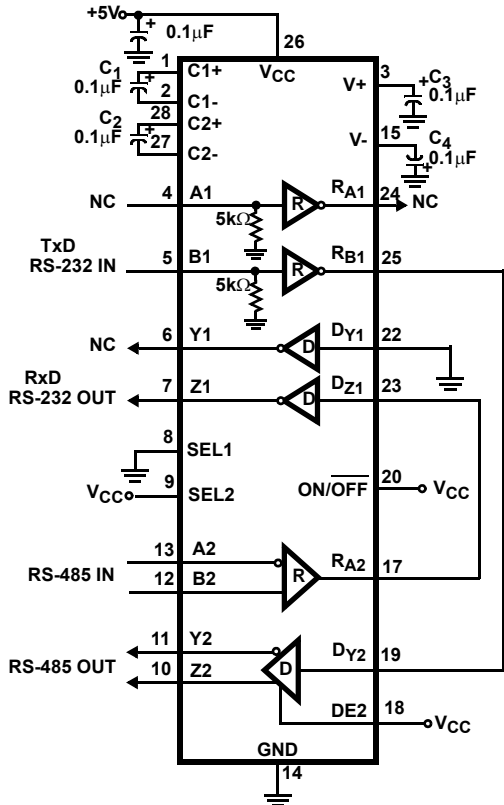

NOTE: PINOUT FOR SOIC AND SSOP

FIGURE 8. SINGLE IC RS-232 TO RS-485 CONVERTER

Detailed Description

Each of the two ISLX1334 ports supports dual protocols: RS-485/422, and RS-232. RS-485 and RS-422 are differential (balanced) data transmission standards for use in high speed (up to 20Mbps) networks, or long haul and noisy environments. The differential signaling, coupled with RS-485’s requirement for extended common mode range (CMR) of +12V to -7V make these transceivers extremely tolerant of ground potential differences, as well as voltages induced in the cable by external fields. Both of these effects are real concerns when communicating over the RS-485/422 maximum distance of 4000’ (1220m). It is important to note that the ISLX1334 don’t follow the RS-485 convention whereby the inverting I/O is labeled “B/Z”, and the noninverting I/O is “A/Y”. Thus, in the application diagrams below the 1334 A/Y (B/Z) pins connect to the B/Z (A/Y) pins of the generic RS-485/422 ICs.

RS-422 is typically a point-to-point (one driver talking to one receiver on a bus), or a point-to-multipoint (multidrop) standard that allows only one driver and up to 10 receivers on each bus. Because of the one driver per bus limitation, RS-422 networks use a two bus, full duplex structure for bidirectional communication, and the Rx inputs and Tx outputs (no tri-state required) connect to different busses, as shown in Figure 10.

Conversely, RS-485 is a true multipoint standard, which allows up to 32 devices (any combination of drivers- must be tri-statable - and receivers) on each bus. Now bidirectional communication takes place on a single bus, so the Rx inputs and Tx outputs of a port connect to the same bus lines, as shown in Figure 9. Each port set to RS-485 /422 mode includes one Rx and one Tx.

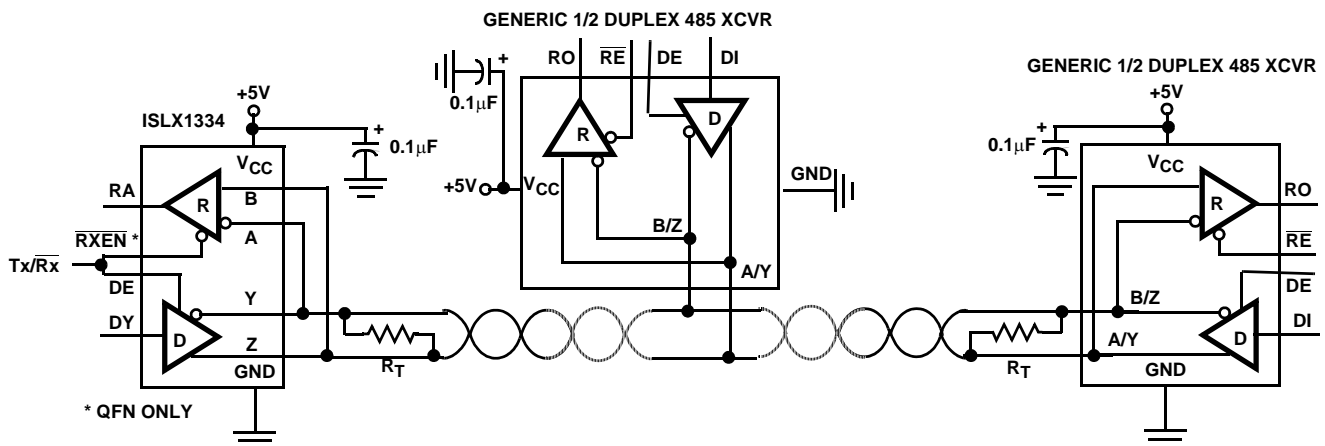

FIGURE 9. TYPICAL HALF DUPLEX RS-485 NETWORK

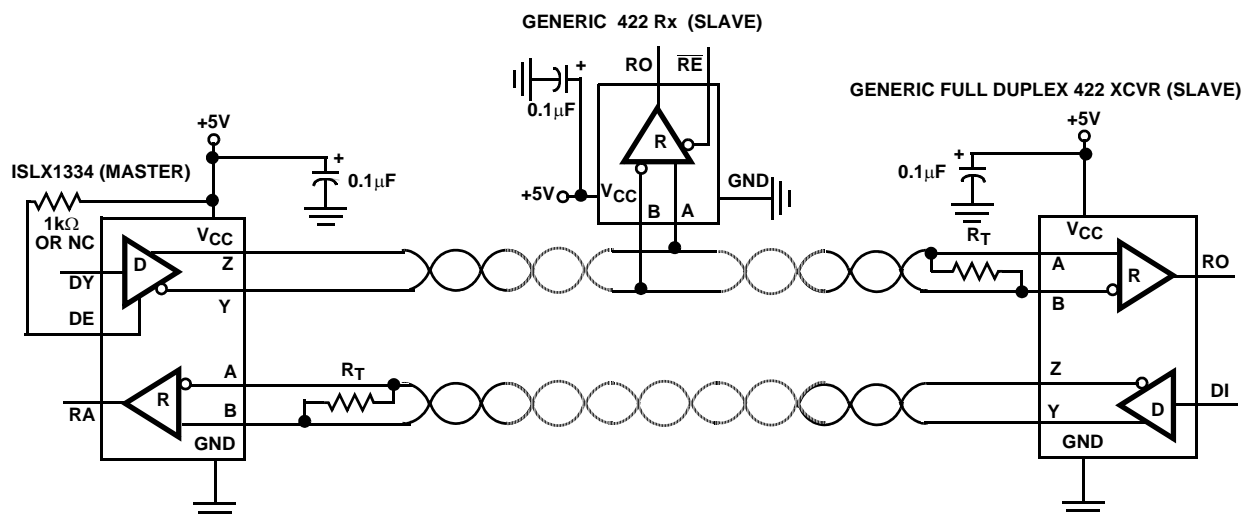

FIGURE 10. TYPICAL RS-422 NETWORK

RS-232 is a point-to-point, singled ended (signal voltages referenced to GND) communication protocol targeting fairly short (<150', 46m) and low data rate (<1Mbps) applications. Each port contains two transceivers (2 Tx and 2 Rx) in RS-232 mode.

Protocol selection is handled via a logic pin (SELX) for each port.

ISLX1334 Advantages

- These dual protocol ICs offer many parametric improvements versus those offered on competing dual protocol devices. Some of the major improvements are:
- 15kV Bus Pin ESD - Eases board level requirements;
- 2.7V Diff V_{OUT} - Better Noise immunity and/or distance;
- Full Failsafe RS-485 Rx - Eliminates bus biasing;
- Selectable RS-485 Data Rate - Up to 20Mbps, or slew rate limited for low EMI and fewer termination issues;
- High RS-232 Data Rate - >460kbps
- Lower Tx and Rx Skews - Wider, consistent bit widths;
- Lower I_{CC} - Max I_{CC} is 2-4X lower than competition;
- Flow-Thru Pinouts - Tx, Rx bus pins on one side/logic pins on the other, for easy routing to connector/UART;
- Smaller (SSOP and QFN) and Pb-free Packaging.

RS-232 Mode

Rx Features

RS-232 receivers invert and convert RS-232 input levels ($\pm 3V$ to $\pm 25V$) to the standard TTL/CMOS levels required by a UART, ASIC, or μ controller serial port. Receivers are designed to operate at faster data rates than the drivers, and they feature very low skews (10ns) so the receivers contribute negligibly to bit width distortion. Inputs include the standards required 3k Ω to 7k Ω pulldown resistor, so unused inputs may be left unconnected. Rx inputs also have built-in hysteresis to increase noise immunity, and to decrease erroneous triggering due to slowly transitioning input signals.

Rx outputs are short circuit protected, and are only tri-statable when the entire IC is shutdown via the ON/OFF pin, or via the active low \overline{RXEN} pin available on the QFN package option (see "ISL41334 Special Features" for more details).

Tx Features

RS-232 drivers invert and convert the standard TTL/CMOS levels from a UART, or μ controller serial port to RS-232 compliant levels ($\pm 5V$ minimum). The Tx delivers these compliant output levels even at data rates of 650kbps, and with loads of 1000pF. The drivers are designed for low skew (typically 12% of the 500kbps bit width), and are compliant to the RS-232 slew rate spec (4 to 30V/ μ s) for a wide range of load capacitances. Tx inputs float if left unconnected, and may cause I_{CC} increases. For the best results, connect unused inputs to GND.

Tx outputs are short circuit protected, and incorporate a thermal SHDN feature to protect the IC in situations of severe power dissipation. See the RS-485 section for more details. Drivers tri-state only in SHDN, or when the 5V power supply is off. The SHDN function is useful for tri-stating the outputs if both ports will always be tri-stated together (e.g., used as a four transceiver RS-232 port), and if it is acceptable for the Rx to be disabled as well. A single port Tx disable can be accomplished by switching the port to RS-485 mode, and then using the corresponding DE pin to tri-state the drivers. Of course, the Rx is now an RS-485 Rx, so this option is feasible only if the Rx aren't needed when the Tx are disabled.

Charge Pumps

The on-chip charge pumps create the RS-232 transmitter power supplies (typically +6/-7V) from a single supply as low as 4.5V, and are enabled only if either port is configured for RS-232 operation. The efficient design requires only four

small 0.1 μ F capacitors for the voltage doubler and inverter functions. By operating discontinuously (i.e., turning off as soon as V+ and V- pump up to the nominal values), the charge pump contribution to RS-232 mode I_{CC} is reduced significantly. Unlike competing devices that require the charge pump in RS-485 mode, disabling the charge pump saves power, and minimizes noise. If the application keeps both ports in RS-485 mode (e.g., a dedicated dual channel RS-485 interface), then the charge pump capacitors aren't even required.

Data Rates and Cabling

Drivers operate at data rates up to 650kbps, and are guaranteed for data rates up to 460kbps. The charge pumps and drivers are designed such that one driver in each port can be operated at the rated load, and at 460kbps (see Figure 34). Figure 34 also shows that drivers can easily drive several thousands of picofarads at data rates up to 250kbps, while still delivering compliant $\pm 5V$ output levels.

Receivers operate at data rates up to 2Mbps. They are designed for a higher data rate to facilitate faster factory downloading of software into the final product, thereby improving the user's manufacturing throughput.

Figures 37 and 38 illustrate driver and receiver waveforms at 250kbps, and 500kbps, respectively. For these graphs, one driver of each port drives the specified capacitive load, and a receiver in the port.

RS-232 doesn't require anything special for cabling; just a single bus wire per transmitter and receiver, and another wire for GND. So an ISLX1334 RS-232 port uses a five conductor cable for interconnection. Bus terminations are not required, nor allowed, by the RS-232 standard.

RS-485 Mode

Rx Features

RS-485 receivers convert differential input signals as small as 200mV, as required by the RS-485 and RS-422 standards, to TTL/CMOS output levels. The differential Rx provides maximum sensitivity, noise immunity, and common mode rejection. Per the RS-485 standard, receiver inputs function with common mode voltages as great as $\pm 7V$ outside the power supplies (i.e., +12V and -7V), making them ideal for long networks where induced voltages are a realistic concern. Each RS-485/422 port includes a single receiver (RA), and the unused Rx output (RB) is disabled, but pulled high by an internal current source. The internal current source turns off in SHDN.

Worst case receiver input currents are 20% lower than the "unit load" (1mA) RS-485 limit, which translates to a 15k Ω minimum input resistance.

These receivers include a "full fail-safe" function that guarantees a high level receiver output if the receiver inputs are unconnected (floating), shorted together, or if the bus is

terminated but undriven (i.e., differential voltage collapses to near zero due to termination). Failsafe with shorted, or terminated and undriven inputs is accomplished by setting the Rx upper switching point at -40mV, thereby ensuring that the Rx recognizes a 0V differential as a high level.

All the Rx outputs are short circuit protected, and are tri-state when the IC is forced into SHDN, but ISL81334 (SOIC and SSOP) receiver outputs are not independently tri-statable. ISL41334 (QFN) receiver outputs are tri-statable via an active low RXEN input for each port (see "ISL41334 Special Features" for more details).

Tx Features

The RS-485/422 driver is a differential output device that delivers at least 2.2V across a 54 Ω load (RS-485), and at least 2.5V across a 100 Ω load (RS-422). Both levels significantly exceed the standards requirements, and these exceptional output voltages increase system noise immunity, and/or allow for transmission over longer distances. The drivers feature low propagation delay skew to maximize bit widths, and to minimize EMI.

To allow multiple drivers on a bus, the RS-485 spec requires that drivers survive worst case bus contentions undamaged. The ISLX1334 drivers meet this requirement via driver output short circuit current limits, and on-chip thermal shutdown circuitry. The output stages incorporate current limiting circuitry that ensures that the output current never exceeds the RS-485 spec, even at the common mode voltage range extremes. In the event of a major short circuit condition, devices also include a thermal shutdown feature that disables the drivers whenever the die temperature becomes excessive. This eliminates the power dissipation, allowing the die to cool. The drivers automatically re-enable after the die temperature drops about 15 degrees. If the contention persists, the thermal shutdown/re-enable cycle repeats until the fault is cleared. Receivers stay operational during thermal shutdown.

RS-485 multi-driver operation also requires drivers to include tri-state functionality, so each port has a DE pin to control this function. If the driver is used in an RS-422 network, such that driver tri-state isn't required, then the DE pin can be left unconnected and an internal pull-up keeps it in the enabled state. Drivers are also tri-stated when the IC is in SHDN, or when the 5V power supply is off.

Speed Options

The ISL81334 (SOIC/SSOP) has fixed, high slew rate driver outputs optimized for 20Mbps data rates. The ISL41334 (QFN) offers three user selectable data rate options: "Fast" for high slew rate and 20Mbps; "Medium" with slew rate limiting set for 460kbps; "Slow" with even more slew rate limiting for 115kbps operation. See the "Data Rate" and "Slew Rate Limited Data Rates" sections for more information.

Receiver performance is the same for all three speed options.

Data Rate, Cables, and Terminations

RS-485/422 are intended for network lengths up to 4000' (1220m), but the maximum system data rate decreases as the transmission length increases. Devices operating at the maximum data rate of 20Mbps are limited to lengths of 20-30' (6-9m), while devices operating at or below 115kbps can operate at the maximum length of 4000' (1220m).

Higher data rates require faster edges, so both the ISLX1334 versions offer an edge rate capable of 20Mbps data rates. The ISL41334 also offers two slew rate limited edge rates to minimize problems at slower data rates. Nevertheless, for the best jitter performance when driving long cables, the faster speed settings may be preferable, even at low data rates. See the "RS-485 Slew Rate Limited Data Rates" section for details.

Twisted pair is the cable of choice for RS-485/422 networks. Twisted pair cables tend to pick up noise and other electromagnetically induced voltages as common mode signals, which are effectively rejected by the differential receivers in these ICs.

The preferred cable connection technique is "daisy-chaining", where the cable runs from the connector of one device directly to the connector of the next device, such that cable stub lengths are negligible. A "backbone" structure, where stubs run from the main backbone cable to each device's connector, is the next best choice, but care must be taken to ensure that each stub is electrically "short". See Table 4 for recommended maximum stub lengths for each speed option.

TABLE 4. RECOMMENDED STUB LENGTHS

SPEED OPTION	MAXIMUM STUB LENGTH ft (m)
SLOW	350-500 (107-152)
MED	100-150 (30.5 - 46)
FAST	1-3 (0.3 - 0.9)

Proper termination is imperative to minimize reflections when using the 20Mbps speed option. Short networks using the medium and slow speed options need not be terminated, but terminations are recommended unless power dissipation is an overriding concern. Note that the RS-485 spec allows a maximum of two terminations on a network, otherwise the Tx output voltage may not meet the required V_{OD} .

In point-to-point, or point-to-multipoint (RS-422) networks, the main cable should be terminated in its characteristic impedance (typically 120Ω) at the end farthest from the driver. In multi-receiver applications, stubs connecting receivers to the main cable should be kept as short as possible, but definitely shorter than the limits shown in Table 4. Multipoint (RS-485) systems require that the main cable be terminated in its characteristic impedance at both ends. Again, keep stubs connecting a transceiver to the main

cable as short as possible, and refer to Table 4. Avoid "star", and other configurations, where there are many "ends" which would require more than the two allowed terminations to prevent reflections.

High ESD

All pins on the ISLX1334 include ESD protection structures rated at ±4kV (HBM), which is good enough to survive ESD events commonly seen during manufacturing. But the bus pins (Tx outputs and Rx inputs) are particularly vulnerable to ESD events because they connect to an exposed port on the exterior of the finished product. Simply touching the port pins, or connecting a cable, can destroy an unprotected port. ISLX1334 bus pins are fitted with advanced structures that deliver ESD protection in excess of ±15kV (HBM), without interfering with any signal in the RS-485 or the RS-232 range. This high level of protection may eliminate the need for board level protection, or at the very least will increase the robustness of any board level scheme.

Small Packages

Many competing dual protocol ICs are available only in monstrously large 24 to 28 Ld SOIC packages. The ISL81334's 28 Ld SSOP is 50% smaller than even a 24 Ld SOIC, and the ISL41334's tiny 6x6mm QFN is 80% smaller than a 28 Ld SOIC.

Flow Through Pinouts

Even the ISLX1334 pinouts are features, in that the "flow-through" design simplifies board layout. Having the bus pins all on one side of the package for easy routing to a cable connector, and the Rx outputs and Tx inputs on the other side for easy connection to a UART, avoids costly and problematic crossovers. Figure 11 illustrates the flow-through nature of the pinout.

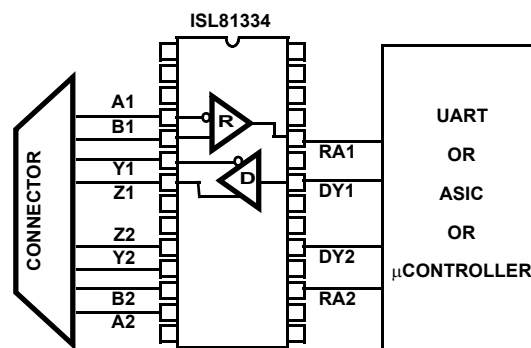

FIGURE 11. ILLUSTRATION OF FLOW THROUGH PINOUT

Low Power Shutdown (SHDN) Mode

The ON/OFF pin is driven low to place the IC (both ports) in the SHDN mode, and the already low supply current drops to as low as 25μA. If this functionality isn't desired, the pin can be left disconnected (thanks to the internal pull-up), or it should be connected to V_{CC} (V_L for the QFN), through a 1kΩ resistor. SHDN disables the Tx and Rx outputs, and

disables the charge pumps if either port is in RS-232 mode, so V+ collapses to V_{CC}, and V- collapses to GND.

All but 5uA of SHDN I_{CC} current is due to control input (ON, LB, SP, DE) pull-up resistors (~20uA/resistor), so SHDN I_{CC} varies depending on the ISLX1334 configuration. The spec tables indicate the worst case values, but careful selection of the configuration yields lower currents. For example, in RS-232 mode the SP pins aren't used, so if both ports are configured for RS-232, floating or tying the SP pins high minimizes SHDN I_{CC}. Likewise in RS-485 mode, the drivers are disabled in SHDN, so driving the DE pins high during this time also reduces I_{CC}.

On the ISL41334, the SHDN I_{CC} increases as V_L decreases. V_L powers the input stage and sets its V_{OH} at V_L rather than V_{CC}. V_{CC} powers the second stage, but the second stage input isn't driven to the rail, so some I_{CC} current flows. See Figure 21 for details.

When enabling from SHDN in RS-232 mode, allow at least 20uS for the charge pumps to stabilize before transmitting data. The charge pumps aren't used in RS-485 mode, so the transceiver is ready to send or receive data in less than 1uS, which is much faster than competing devices that require the charge pump for all modes of operation.

Internal Loopback Mode

Driving the LB pin low places both ports in the loopback mode, a mode that facilitates implementing board level self test functions. In loopback, internal switches disconnect the Rx inputs from the Rx outputs, and feed back the Tx outputs to the appropriate Rx output. This way the data driven at the Tx input appears at the corresponding Rx output (refer to "Typical Operating Circuits"). The Tx outputs remain connected to their terminals, so the external loads are reflected in the loopback performance. This allows the loopback function to potentially detect some common bus faults such as one or both driver outputs shorted to GND, or outputs shorted together.

Note that the loopback mode uses an additional set of receivers, as shown in the "Typical Operating Circuits". These loopback receivers are not standards compliant, so the loopback mode can't be used to implement a half-duplex RS-485 transceiver.

If loopback won't be utilized, the pin can be left disconnected (thanks to the internal pull-up), or it should be connected to V_{CC} (V_L for the QFN), through a 1kΩ resistor.

ISL41334 (QFN Package) Special Features

Logic Supply (V_L Pin)

The ISL41334 (QFN) includes a V_L pin that powers the logic inputs (Tx inputs and control pins) and Rx outputs. These pins interface with "logic" devices such as UARTs, ASICs, and μcontrollers, and today most of these devices use power supplies significantly lower than 5V. Thus, a 5V output level

from a 5V powered dual protocol IC might seriously overdrive and damage the logic device input. Similarly, the the logic device's low V_{OH} might not exceed the V_{IH} of a 5V powered dual protocol input. Connecting the V_L pin to the power supply of the logic device - as shown in Figure 12 - limits the ISL41334's Rx output V_{OH} to V_L (see Figure 15), and reduces the Tx and control input switching points to values compatible with the logic device output levels. Tailoring the logic pin input switching points and output levels to the supply voltage of the UART, ASIC, or μcontroller eliminates the need for a level shifter/translator between the two ICs.

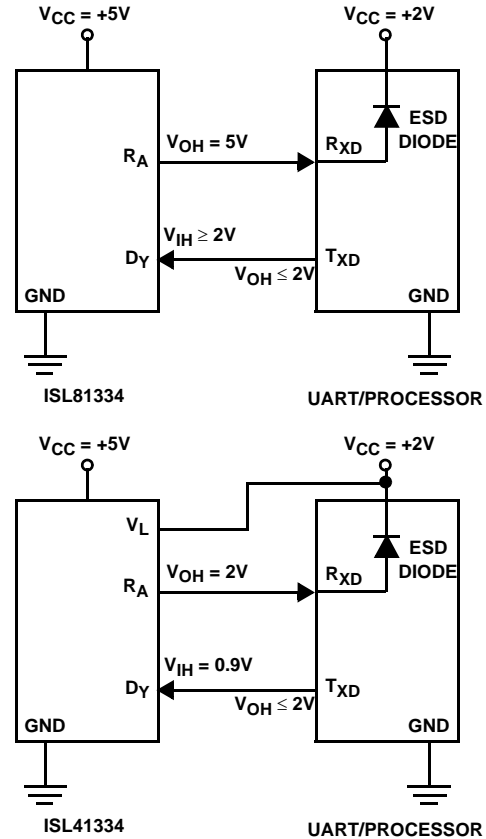

FIGURE 12. USING V_L PIN TO ADJUST LOGIC LEVELS

V_L can be anywhere from V_{CC} down to 1.65V, but the input switching points may not provide enough noise margin when V_L < 1.8V. Table 5 indicates typical V_{IH} and V_{IL} values for various V_L values so the user can ascertain whether or not a particular V_L voltage meets his needs.

TABLE 5. V_{IH} AND V_{IL} vs. V_L FOR V_{CC} = 5V

V _L (V)	V _{IH} (V)	V _{IL} (V)
1.65V	0.79	0.50
1.8V	0.82	0.60
2.0V	0.87	0.69
2.5V	0.99	0.86
3.3V	1.19	1.05

Typical Performance Curves $V_{CC} = V_L = 5V$, $T_A = 25^\circ C$; Unless Otherwise Specified

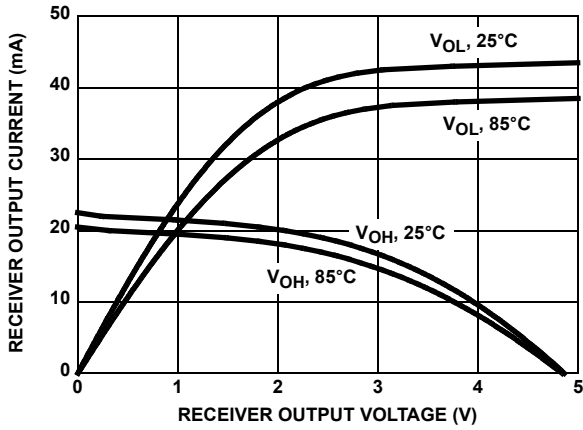

FIGURE 14. RECEIVER OUTPUT CURRENT vs RECEIVER OUTPUT VOLTAGE

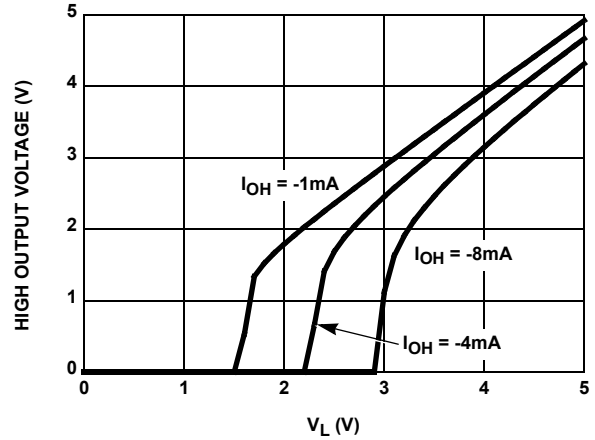

FIGURE 15. RECEIVER HIGH OUTPUT VOLTAGE vs LOGIC SUPPLY VOLTAGE (V_L)

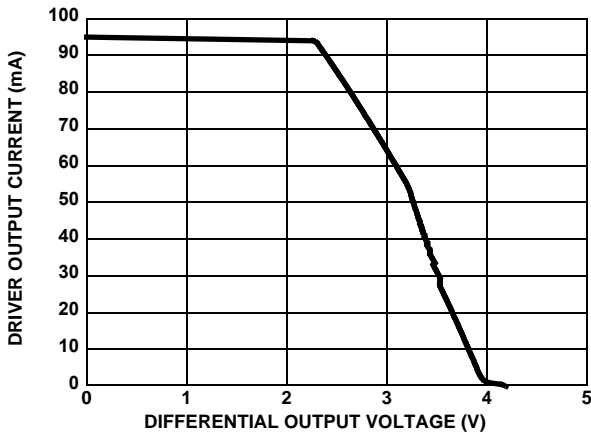

FIGURE 16. RS-485, DRIVER OUTPUT CURRENT vs DIFFERENTIAL OUTPUT VOLTAGE

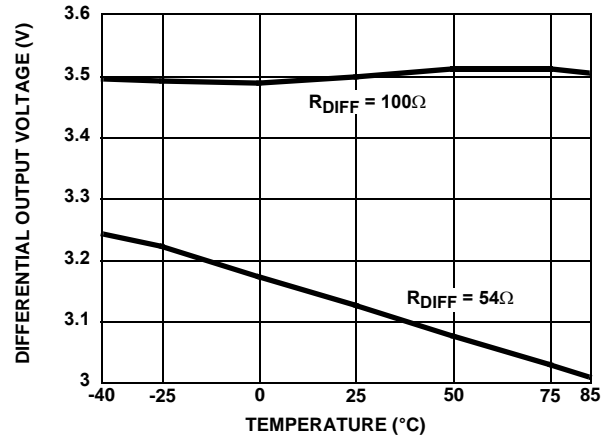

FIGURE 17. RS-485, DRIVER DIFFERENTIAL OUTPUT VOLTAGE vs TEMPERATURE

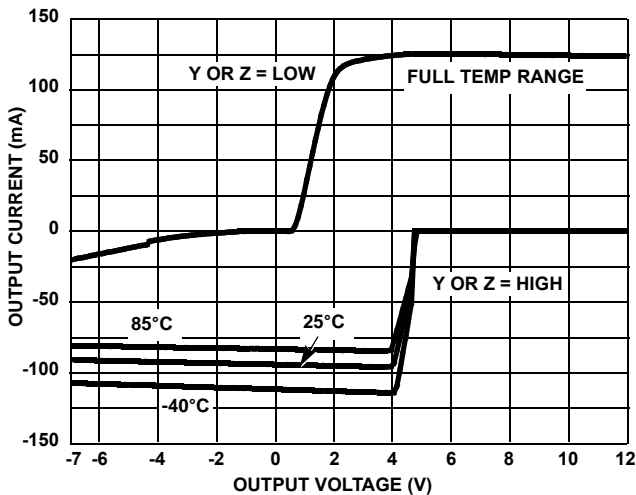

FIGURE 18. RS-485, DRIVER OUTPUT CURRENT vs SHORT CIRCUIT VOLTAGE

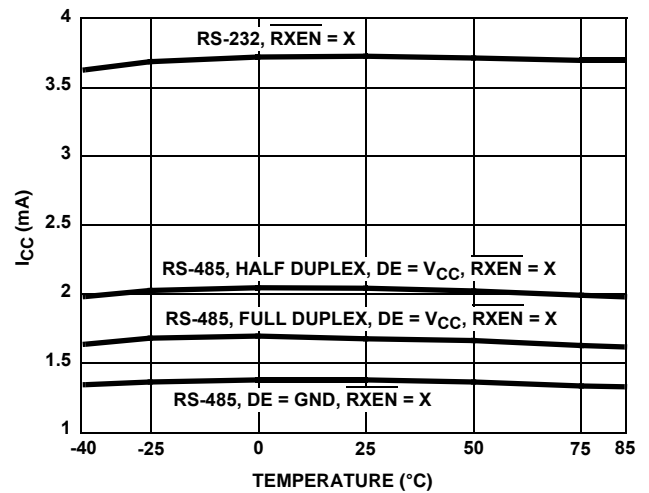

FIGURE 19. SUPPLY CURRENT vs TEMPERATURE

Typical Performance Curves $V_{CC} = V_L = 5V$, $T_A = 25^\circ C$; Unless Otherwise Specified (Continued)

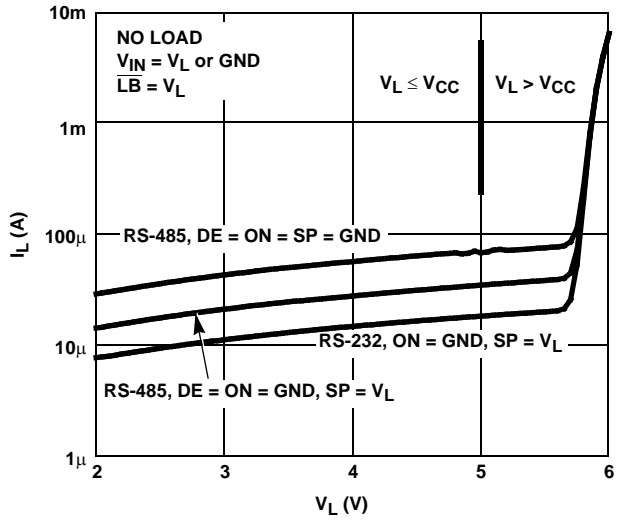

FIGURE 20. RS-232, V_L SUPPLY CURRENT vs V_L VOLTAGE (QFN ONLY)

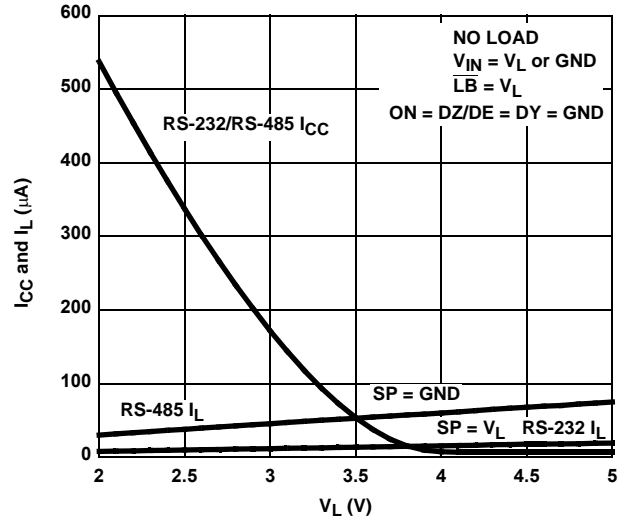

FIGURE 21. V_{CC} and V_L SHDN SUPPLY CURRENTS vs V_L VOLTAGE (QFN ONLY)

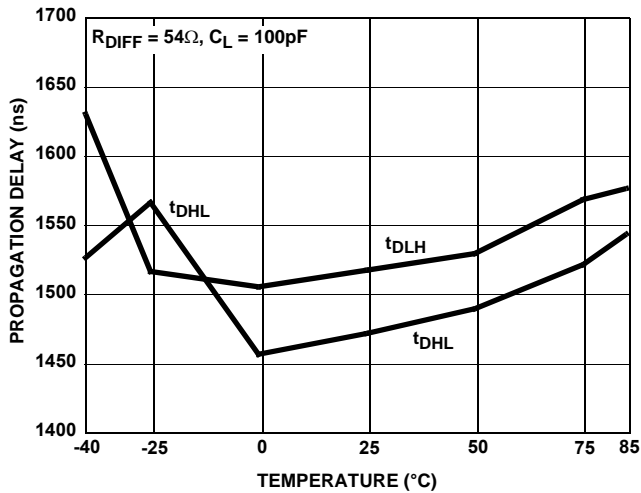

FIGURE 22. RS-485, DRIVER PROPAGATION DELAY vs TEMPERATURE (SLOW DATA RATE, QFN ONLY)

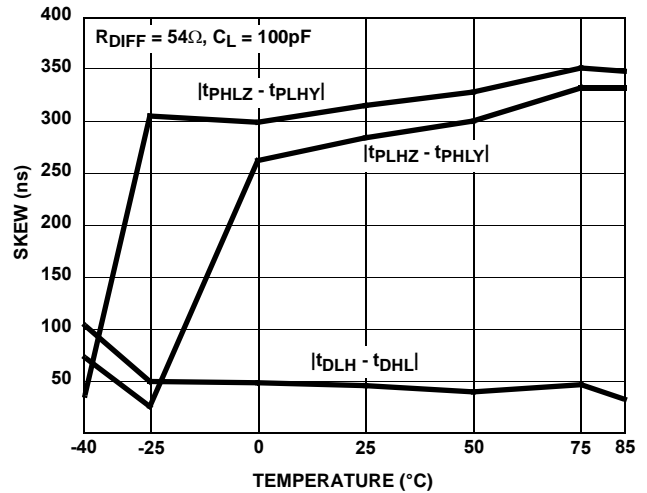

FIGURE 23. RS-485, DRIVER SKEW vs TEMPERATURE (SLOW DATA RATE, QFN ONLY)

Typical Performance Curves $V_{CC} = V_L = 5V$, $T_A = 25^\circ C$; Unless Otherwise Specified (Continued)

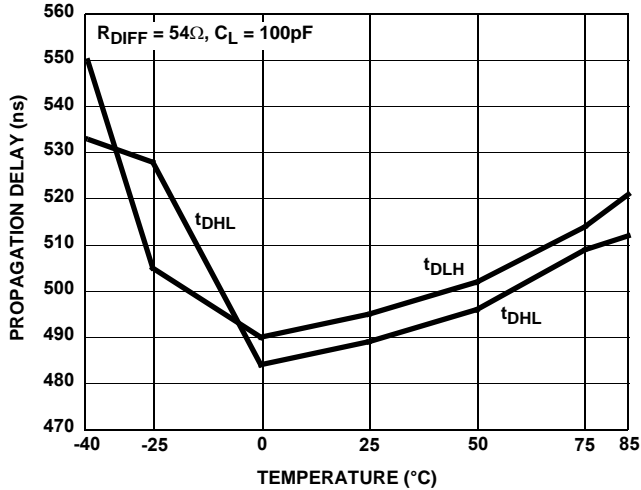

FIGURE 24. RS-485, DRIVER PROPAGATION DELAY vs TEMPERATURE (MEDIUM DATA RATE, QFN ONLY)

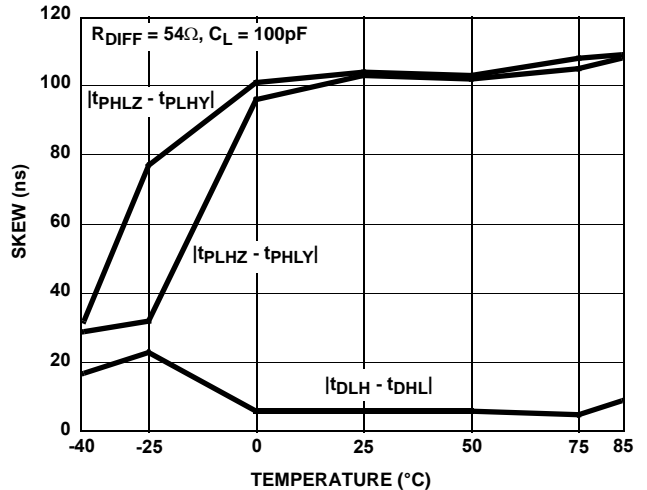

FIGURE 25. RS-485, DRIVER SKEW vs TEMPERATURE (MEDIUM DATA RATE, QFN ONLY)

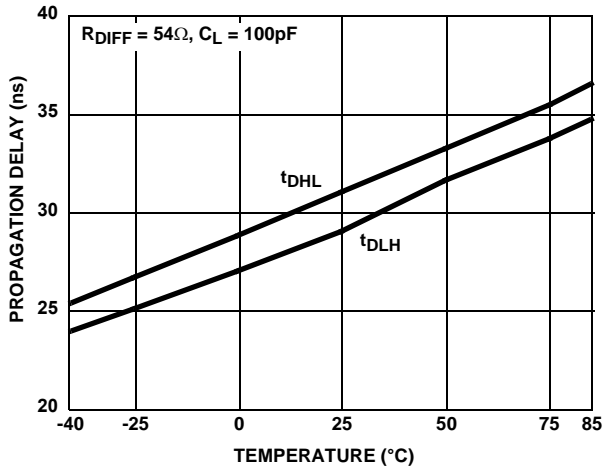

FIGURE 26. RS-485, DRIVER PROPAGATION DELAY vs TEMPERATURE (FAST DATA RATE)

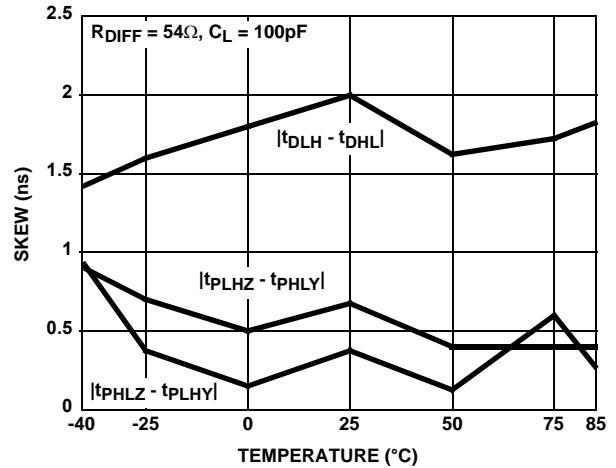

FIGURE 27. RS-485, DRIVER SKEW vs TEMPERATURE (FAST DATA RATE)

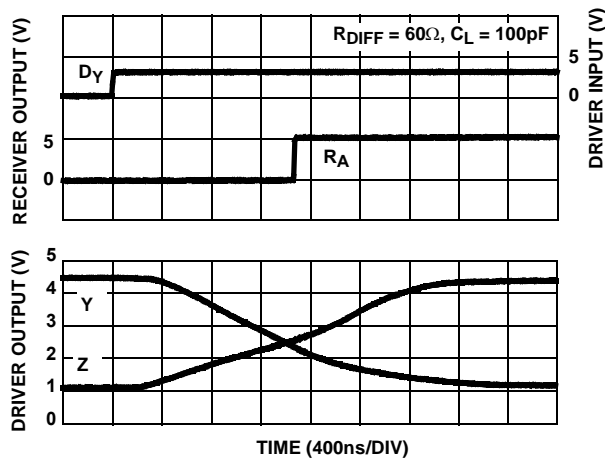

FIGURE 28. RS-485, DRIVER AND RECEIVER WAVEFORMS, LOW TO HIGH (SLOW DATA RATE, QFN ONLY)

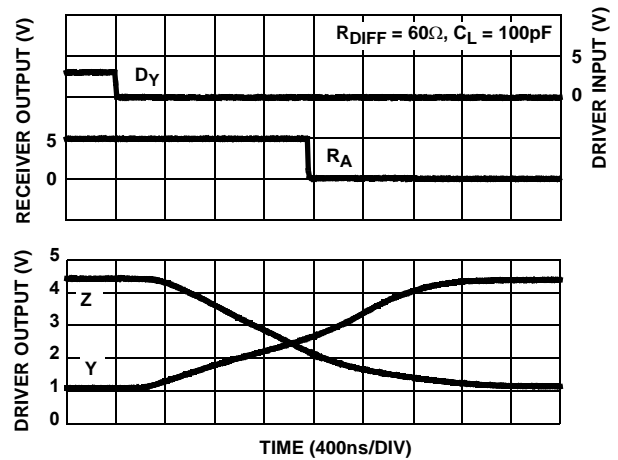

FIGURE 29. RS-485, DRIVER AND RECEIVER WAVEFORMS, HIGH TO LOW (SLOW DATA RATE, QFN ONLY)

Typical Performance Curves $V_{CC} = V_L = 5V$, $T_A = 25^\circ C$; Unless Otherwise Specified (Continued)

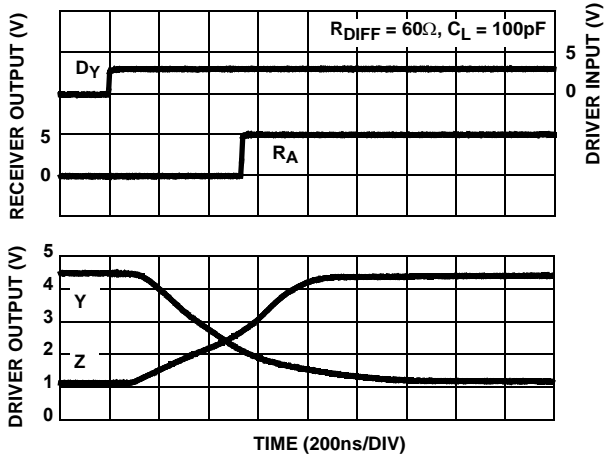

FIGURE 30. RS-485, DRIVER AND RECEIVER WAVEFORMS, LOW TO HIGH (MEDIUM DATA RATE, QFN ONLY)

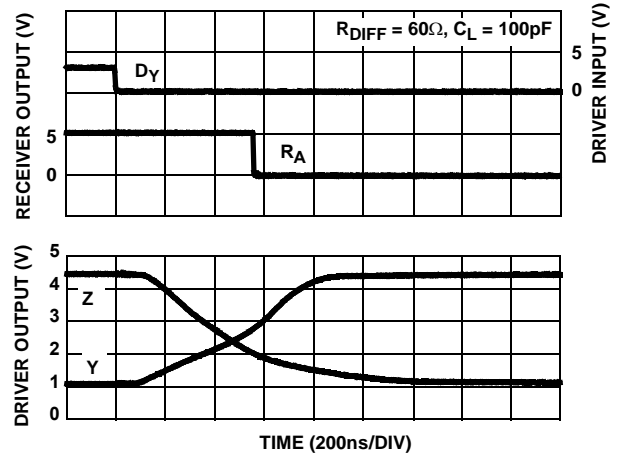

FIGURE 31. RS-485, DRIVER AND RECEIVER WAVEFORMS, HIGH TO LOW (MEDIUM DATA RATE, QFN ONLY)

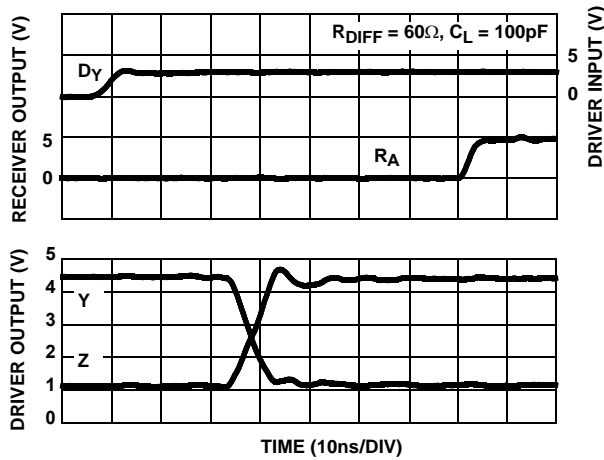

FIGURE 32. RS-485, DRIVER AND RECEIVER WAVEFORMS, LOW TO HIGH (FAST DATA RATE)

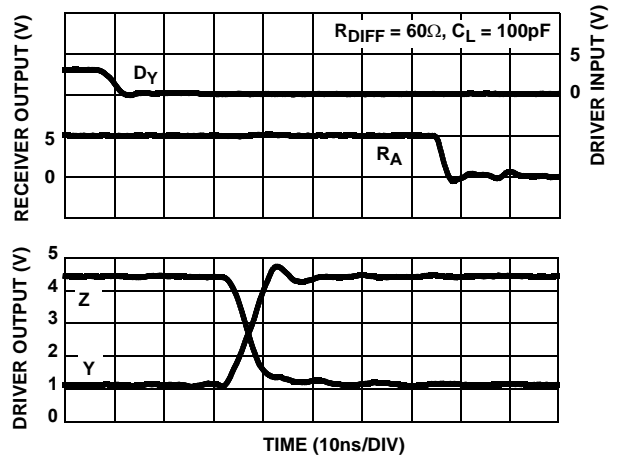

FIGURE 33. RS-485, DRIVER AND RECEIVER WAVEFORMS, HIGH TO LOW (FAST DATA RATE)

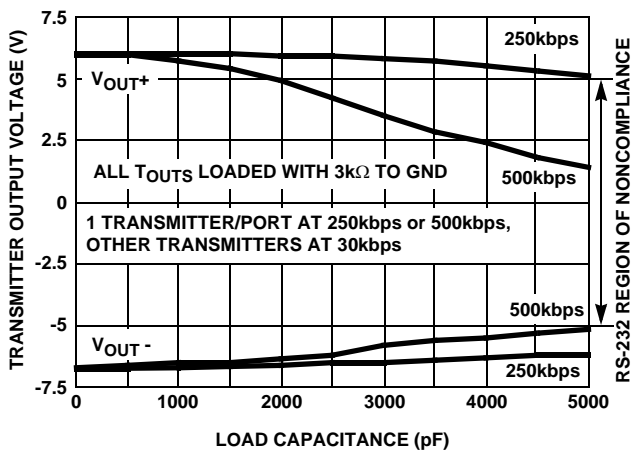

FIGURE 34. RS-232, TRANSMITTER OUTPUT VOLTAGE vs LOAD CAPACITANCE

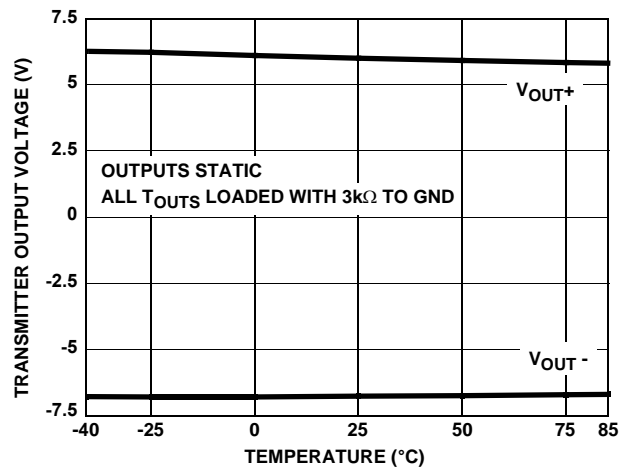

FIGURE 35. RS-232, TRANSMITTER OUTPUT VOLTAGE vs TEMPERATURE

Typical Performance Curves $V_{CC} = V_L = 5V$, $T_A = 25^\circ C$; Unless Otherwise Specified (Continued)

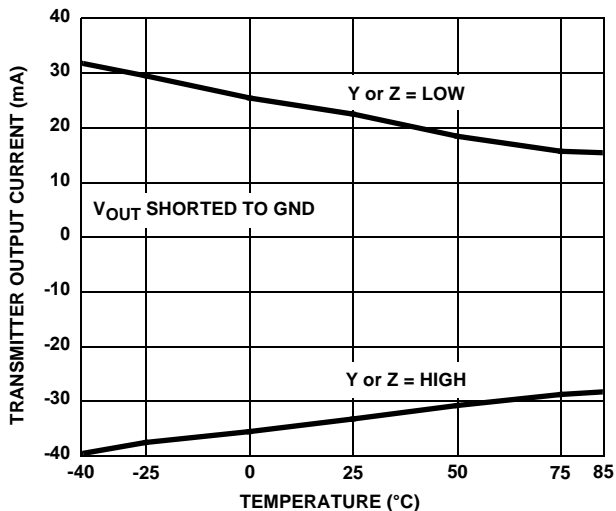

FIGURE 36. RS-232, TRANSMITTER SHORT CIRCUIT CURRENT vs TEMPERATURE

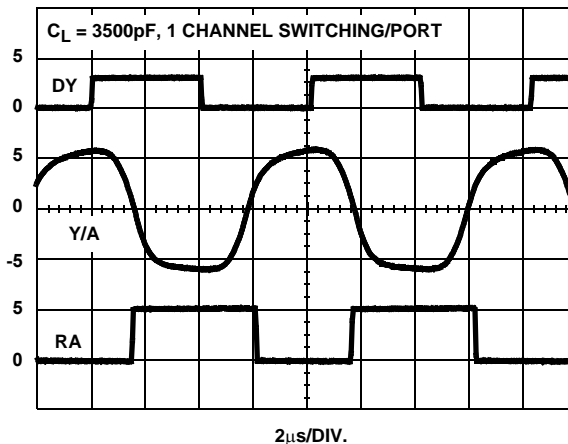

FIGURE 37. RS-232, TRANSMITTER AND RECEIVER WAVEFORMS AT 250kbps

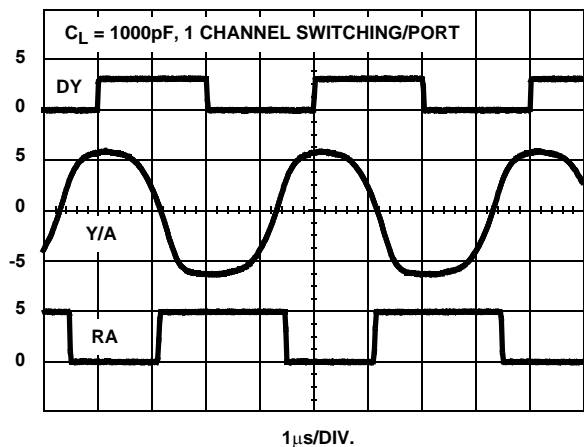

FIGURE 38. RS-232, TRANSMITTER AND RECEIVER WAVEFORMS AT 500kbps

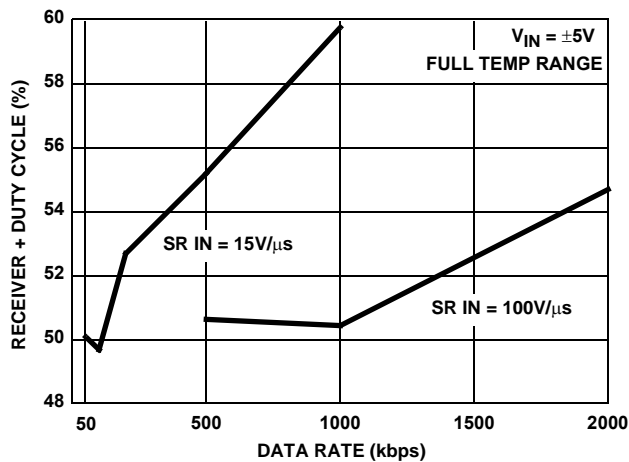

FIGURE 39. RS-232, RECEIVER OUTPUT + DUTY CYCLE vs DATA RATE

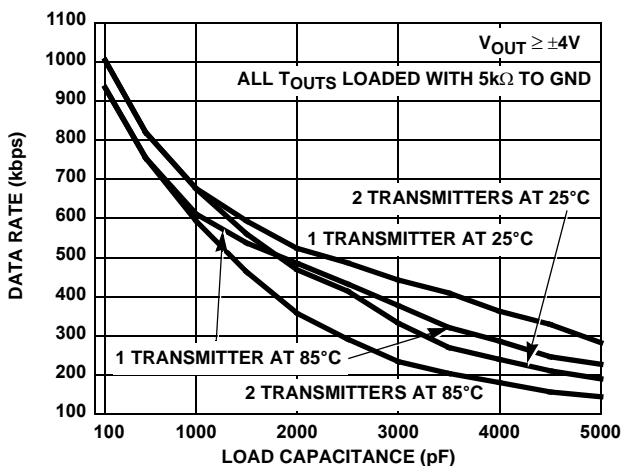

FIGURE 40. RS-232, TRANSMITTER MAXIMUM DATA RATE vs LOAD CAPACITANCE

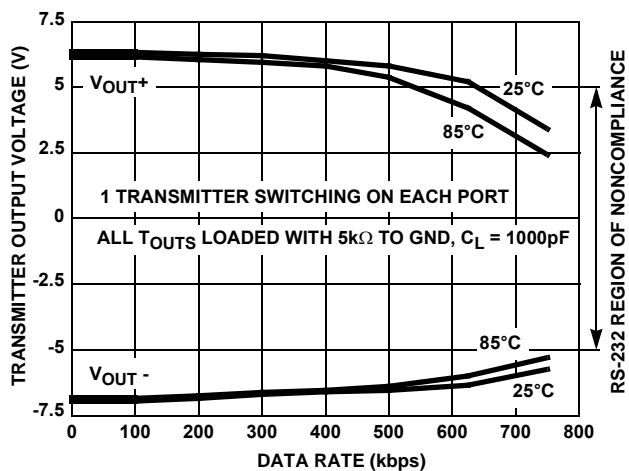

FIGURE 41. RS-232, TRANSMITTER OUTPUT VOLTAGE vs DATA RATE

Typical Performance Curves $V_{CC} = V_L = 5V$, $T_A = 25^\circ C$; Unless Otherwise Specified (Continued)

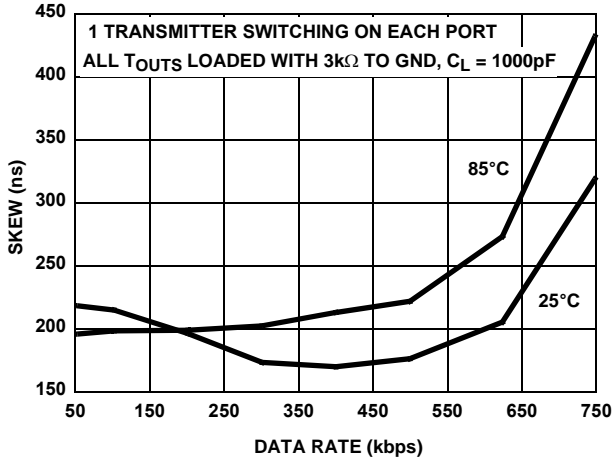

FIGURE 42. RS-232, TRANSMITTER SKEW vs DATA RATE

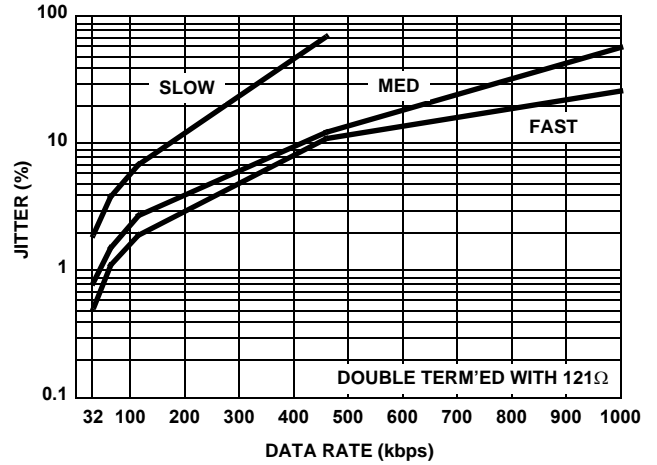

FIGURE 43. RS-485, TRANSMITTER JITTER vs DATA RATE WITH 2000' CAT 5 CABLE

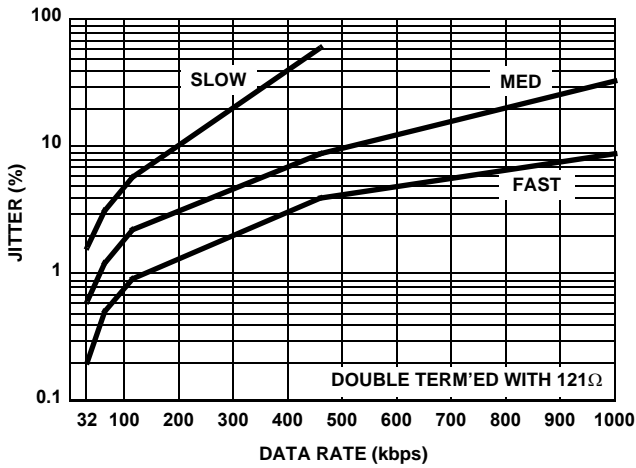

FIGURE 44. RS-485, TRANSMITTER JITTER vs DATA RATE WITH 1000' CAT 5 CABLE

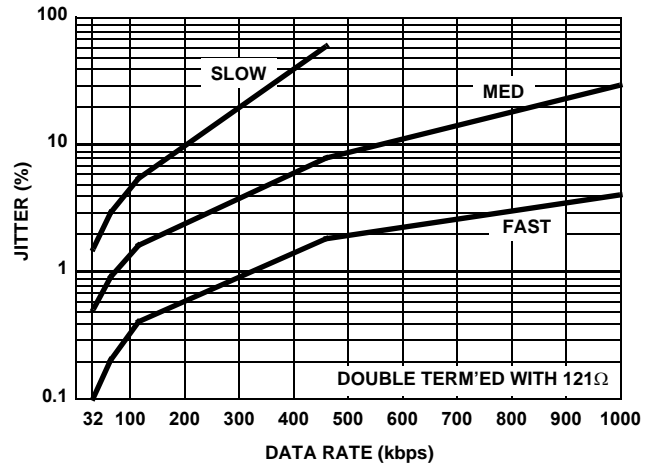

FIGURE 45. RS-485, TRANSMITTER JITTER vs DATA RATE WITH 350' CAT 5 CABLE

Die Characteristics

SUBSTRATE POTENTIAL (POWERED UP):

GND

TRANSISTOR COUNT:

4838

PROCESS:

BiCMOS

Small Outline Plastic Packages (SOIC)

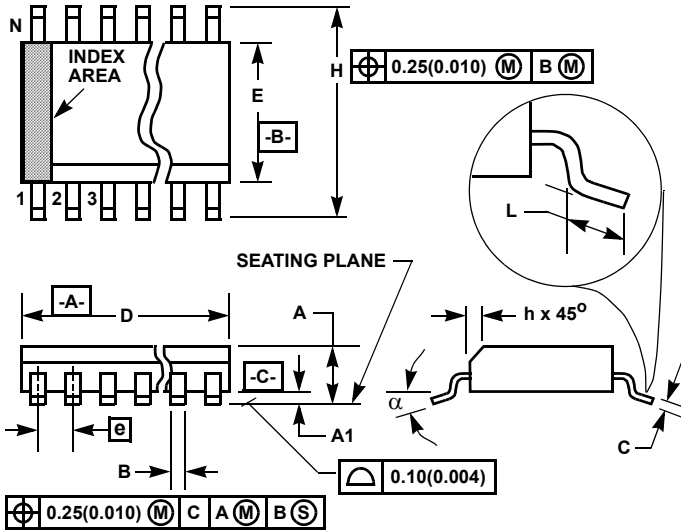

M28.3 (JEDEC MS-013-AE ISSUE C)
28 LEAD WIDE BODY SMALL OUTLINE PLASTIC PACKAGE

SYMBOL	INCHES		MILLIMETERS		NOTES
	MIN	MAX	MIN	MAX	
A	0.0926	0.1043	2.35	2.65	-
A1	0.0040	0.0118	0.10	0.30	-
B	0.013	0.0200	0.33	0.51	9
C	0.0091	0.0125	0.23	0.32	-
D	0.6969	0.7125	17.70	18.10	3
E	0.2914	0.2992	7.40	7.60	4
e	0.05 BSC		1.27 BSC		-
H	0.394	0.419	10.00	10.65	-
h	0.01	0.029	0.25	0.75	5
L	0.016	0.050	0.40	1.27	6
N	28		28		7
α	0°	8°	0°	8°	-

NOTES:

1. Symbols are defined in the "MO Series Symbol List" in Section 2.2 of Publication Number 95.
2. Dimensioning and tolerancing per ANSI Y14.5M-1982.
3. Dimension "D" does not include mold flash, protrusions or gate burrs. Mold flash, protrusion and gate burrs shall not exceed 0.15mm (0.006 inch) per side.
4. Dimension "E" does not include interlead flash or protrusions. Interlead flash and protrusions shall not exceed 0.25mm (0.010 inch) per side.
5. The chamfer on the body is optional. If it is not present, a visual index feature must be located within the crosshatched area.
6. "L" is the length of terminal for soldering to a substrate.
7. "N" is the number of terminal positions.
8. Terminal numbers are shown for reference only.
9. The lead width "B", as measured 0.36mm (0.014 inch) or greater above the seating plane, shall not exceed a maximum value of 0.61mm (0.024 inch)
10. Controlling dimension: MILLIMETER. Converted inch dimensions are not necessarily exact.

Rev. 0 12/93

Shrink Small Outline Plastic Packages (SSOP)

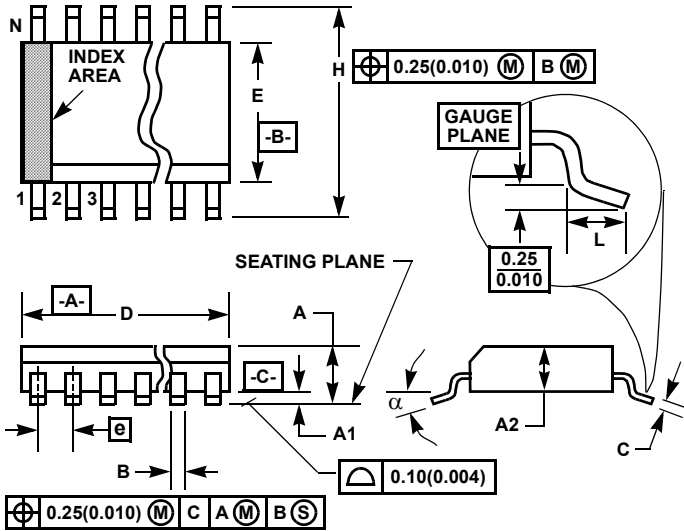

M28.209 (JEDEC MO-150-AH ISSUE B)
28 LEAD SHRINK SMALL OUTLINE PLASTIC PACKAGE

SYMBOL	INCHES		MILLIMETERS		NOTES
	MIN	MAX	MIN	MAX	
A	-	0.078	-	2.00	-
A1	0.002	-	0.05	-	-
A2	0.065	0.072	1.65	1.85	-
B	0.009	0.014	0.22	0.38	9
C	0.004	0.009	0.09	0.25	-
D	0.390	0.413	9.90	10.50	3
E	0.197	0.220	5.00	5.60	4
e	0.026 BSC		0.65 BSC		-
H	0.292	0.322	7.40	8.20	-
L	0.022	0.037	0.55	0.95	6
N	28		28		7
α	0°	8°	0°	8°	-

NOTES:

1. Symbols are defined in the "MO Series Symbol List" in Section 2.2 of Publication Number 95.
2. Dimensioning and tolerancing per ANSI Y14.5M-1982.
3. Dimension "D" does not include mold flash, protrusions or gate burrs. Mold flash, protrusion and gate burrs shall not exceed 0.20mm (0.0078 inch) per side.
4. Dimension "E" does not include interlead flash or protrusions. Interlead flash and protrusions shall not exceed 0.20mm (0.0078 inch) per side.
5. The chamfer on the body is optional. If it is not present, a visual index feature must be located within the crosshatched area.
6. "L" is the length of terminal for soldering to a substrate.
7. "N" is the number of terminal positions.
8. Terminal numbers are shown for reference only.
9. Dimension "B" does not include dambar protrusion. Allowable dambar protrusion shall be 0.13mm (0.005 inch) total in excess of "B" dimension at maximum material condition.
10. Controlling dimension: MILLIMETER. Converted inch dimensions are not necessarily exact.

Rev. 2 6/05

**Quad Flat No-Lead Plastic Package (QFN)
Micro Lead Frame Plastic Package (MLFP)**

L40.6x6
40 LEAD QUAD FLAT NO-LEAD PLASTIC PACKAGE
(COMPLIANT TO JEDEC MO-220VJJD-2 ISSUE C)

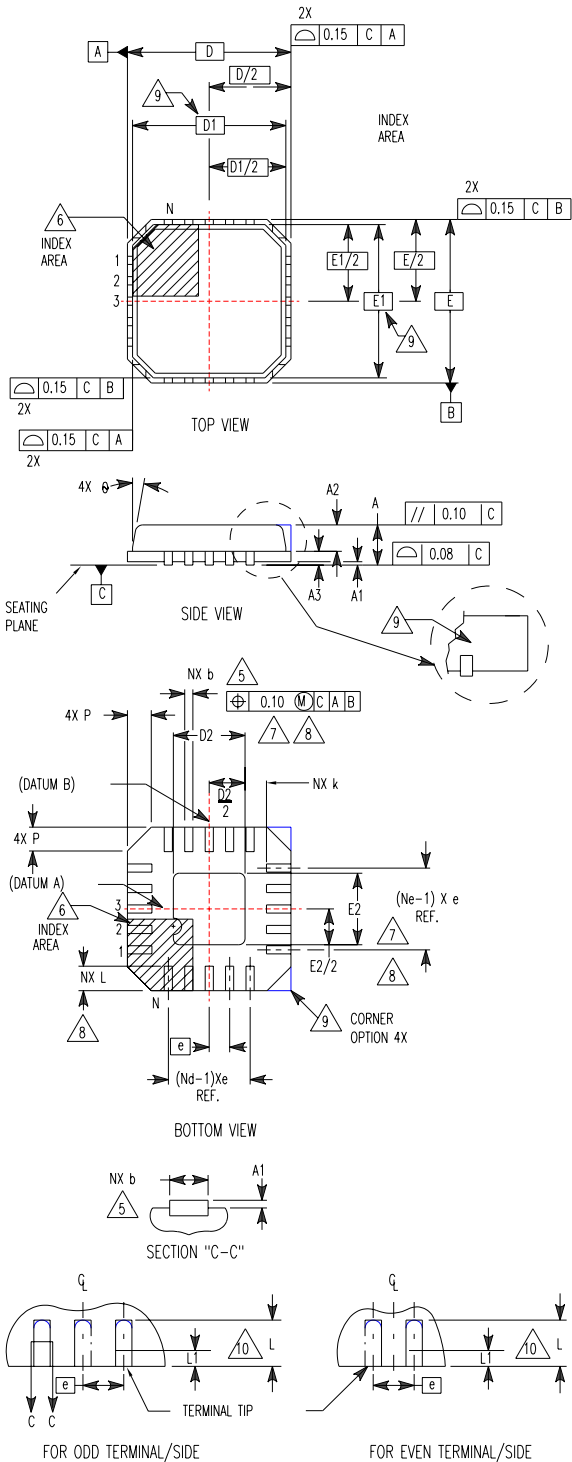

SYMBOL	MILLIMETERS			NOTES
	MIN	NOMINAL	MAX	
A	0.80	0.90	1.00	-
A1	-	-	0.05	-
A2	-	-	1.00	9
A3	0.20 REF			9
b	0.18	0.23	0.30	5, 8
D	6.00 BSC			-
D1	5.75 BSC			9
D2	3.95	4.10	4.25	7, 8
E	6.00 BSC			-
E1	5.75 BSC			9
E2	3.95	4.10	4.25	7, 8
e	0.50 BSC			-
k	0.25	-	-	-
L	0.30	0.40	0.50	8
L1	-	-	0.15	10
N	40			2
Nd	10			3
Ne	10			3
P	-	-	0.60	9
θ	-	-	12	9

Rev. 1 10/02

NOTES:

1. Dimensioning and tolerancing conform to ASME Y14.5-1994.
2. N is the number of terminals.
3. Nd and Ne refer to the number of terminals on each D and E.
4. All dimensions are in millimeters. Angles are in degrees.
5. Dimension b applies to the metallized terminal and is measured between 0.15mm and 0.30mm from the terminal tip.
6. The configuration of the pin #1 identifier is optional, but must be located within the zone indicated. The pin #1 identifier may be either a mold or mark feature.
7. Dimensions D2 and E2 are for the exposed pads which provide improved electrical and thermal performance.
8. Nominal dimensions are provided to assist with PCB Land Pattern Design efforts, see Intersil Technical Brief TB389.
9. Features and dimensions A2, A3, D1, E1, P & θ are present when Anvil singulation method is used and not present for saw singulation.
10. Depending on the method of lead termination at the edge of the package, a maximum 0.15mm pull back (L1) maybe present. L minus L1 to be equal to or greater than 0.3mm.

All Intersil U.S. products are manufactured, assembled and tested utilizing ISO9000 quality systems.
Intersil Corporation's quality certifications can be viewed at www.intersil.com/design/quality

Intersil products are sold by description only. Intersil Corporation reserves the right to make changes in circuit design, software and/or specifications at any time without notice. Accordingly, the reader is cautioned to verify that data sheets are current before placing orders. Information furnished by Intersil is believed to be accurate and reliable. However, no responsibility is assumed by Intersil or its subsidiaries for its use; nor for any infringements of patents or other rights of third parties which may result from its use. No license is granted by implication or otherwise under any patent or patent rights of Intersil or its subsidiaries.

For information regarding Intersil Corporation and its products, see www.intersil.com