

ASSP For Power Supply Applications

6 ch DC/DC Converter IC with Synchronous Rectification

MB39A123

■ DESCRIPTION

MB39A123 is a 6-channel DC/DC converter IC using pulse width modulation (PWM), and it is suitable for up conversion, down conversion, and up/down conversion. MB39A123 is built in 6 channels into BCC-48+/LQFP-48P package and this IC can control and soft-start at each channel. MB39A123 is suitable for power supply of high performance portable instruments such as a digital still camera (DSC).

■ FEATURES

- Supports for step-down with synchronous rectification (ch.1)
- Supports for step-down and up/down Zeta conversion (ch.2 to ch.4)
- Supports for step-up and up/down Sepic conversion (ch.5, ch.6)
- Negative voltage output (Inverting amplifier) (ch.4)
- Low voltage start-up (ch.5, ch.6) : 1.7 V
- Power supply voltage range : 2.5 V to 11 V
- Reference voltage : 2.0 V \pm 1%
- Error amplifier reference voltage : 1.0 V \pm 1% (ch.1), 1.23 V \pm 1% (ch.2 to ch.6)
- Oscillation frequency range : 200 kHz to 2.0 MHz
- Standby current : 0 μ A (Typ)
- Built-in soft-start circuit independent of loads
- Built-in totem-pole type output for MOS FET
- Short-circuit detection capability by external signal (-INS terminal)
- Two types of packages (BCC-48 pin : 1 type, LQFP-48 pin : 1 type)

■ APPLICATIONS

- Digital still camera(DSC)
- Digital video camera(DVC)
- Surveillance camera etc.

MB39A123

■ PIN ASSIGNMENTS

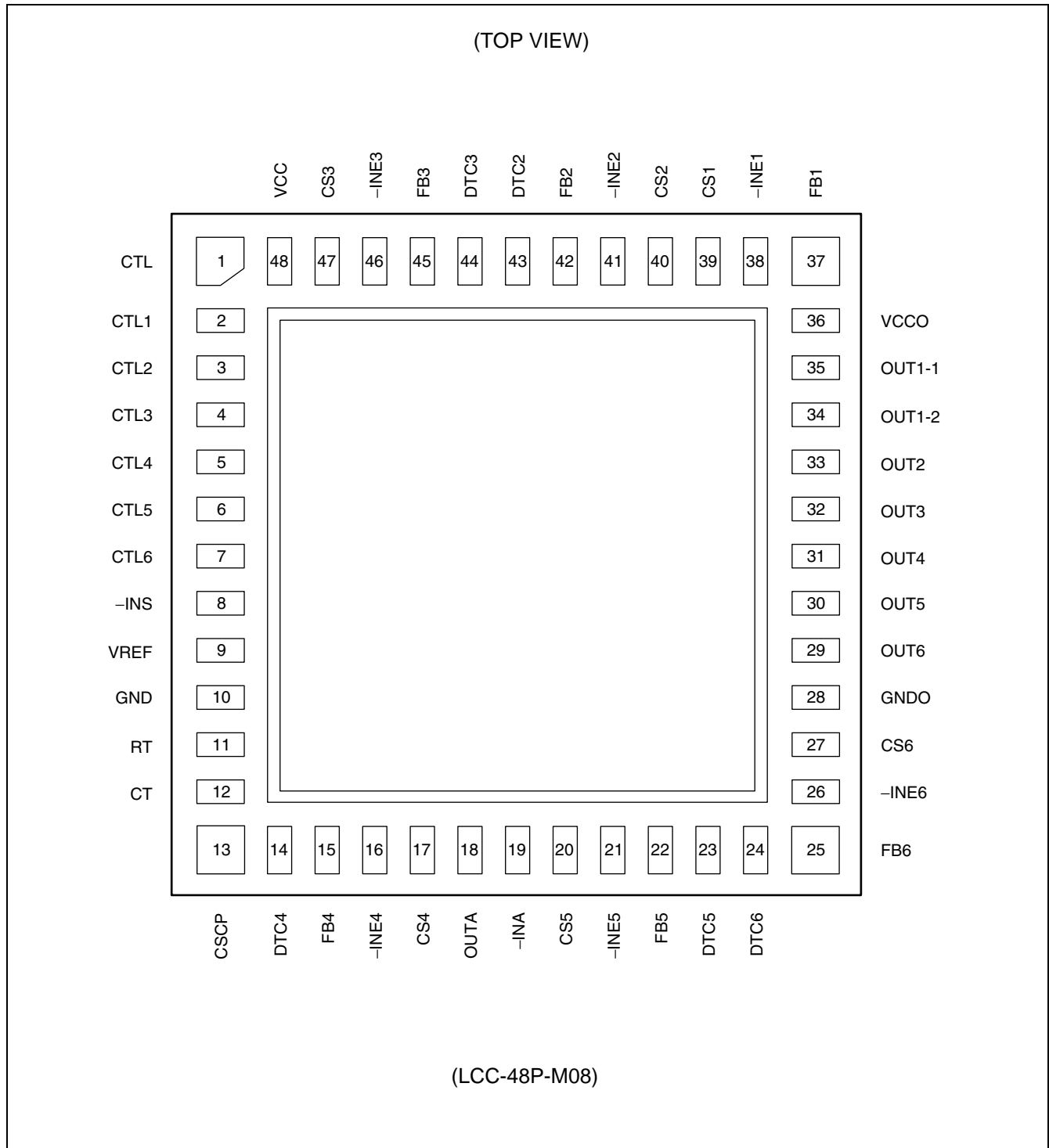

(Continued)

(Continued)

(TOP VIEW)

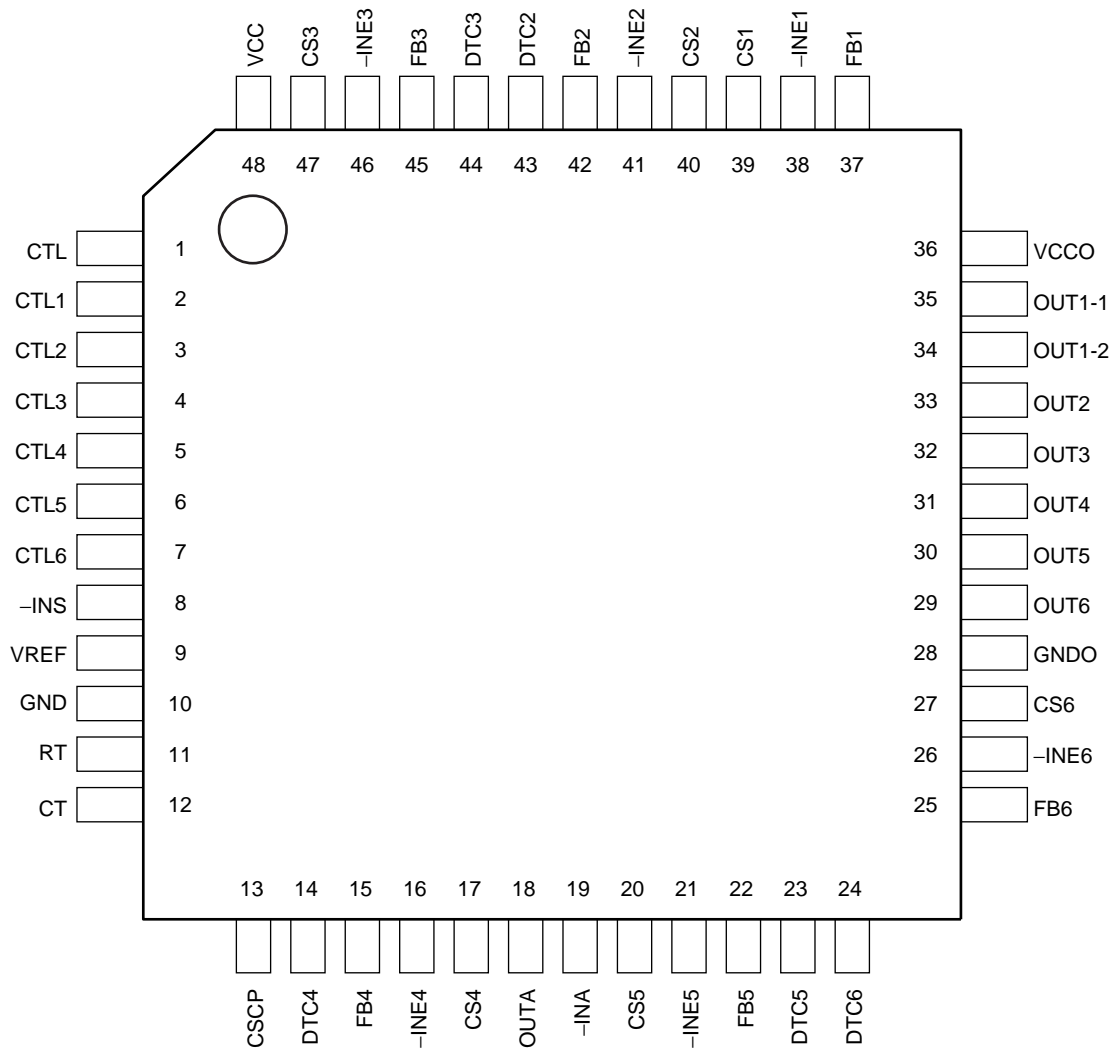

(FPT-48P-M26)

MB39A123

■ PIN DESCRIPTIONS

Block name	Pin No.	Pin name	I/O	Description
ch.1	37	FB1	O	ch.1 • Error amplifier output terminal
	38	-INE1	I	ch.1 • Error amplifier inverted input terminal
	39	CS1	—	ch.1 • Soft-start setting capacitor connection terminal
	35	OUT1-1	O	ch.1 • P-ch drive output terminal (External main side FET gate driving)
	34	OUT1-2	O	ch.1 • N-ch drive output terminal (External synchronous rectification side FET gate driving)
ch.2	43	DTC2	I	ch.2 • Dead time control terminal
	42	FB2	O	ch.2 • Error amplifier output terminal
	41	-INE2	I	ch.2 • Error amplifier inverted input terminal
	40	CS2	—	ch.2 • Soft-start setting capacitor connection terminal
	33	OUT2	O	ch.2 • P-ch drive output terminal
ch.3	44	DTC3	I	ch.3 • Dead time control terminal
	45	FB3	O	ch.3 • Error amplifier output terminal
	46	-INE3	I	ch.3 • Error amplifier inverted input terminal
	47	CS3	—	ch.3 • Soft-start setting capacitor connection terminal
	32	OUT3	O	ch.3 • P-ch drive output terminal
ch.4	14	DTC4	I	ch.4 • Dead time control terminal
	15	FB4	O	ch.4 • Error amplifier output terminal
	16	-INE4	I	ch.4 • Error amplifier inverted input terminal
	17	CS4	—	ch.4 • Soft-start setting capacitor connection terminal
	31	OUT4	O	ch.4 • P-ch drive output terminal
	19	-INA	I	Inverting amplifier input terminal
	18	OUTA	O	Inverting amplifier output terminal
ch.5	23	DTC5	I	ch.5 • Dead time control terminal
	22	FB5	O	ch.5 • Error amplifier output terminal
	21	-INE5	I	ch.5 • Error amplifier inverted input terminal
	20	CS5	—	ch.5 • Soft-start setting capacitor connection terminal
	30	OUT5	O	ch.5 • N-ch drive output terminal
ch.6	24	DTC6	I	ch.6 • Dead time control terminal
	25	FB6	O	ch.6 • Error amplifier output terminal
	26	-INE6	I	ch.6 • Error amplifier inverted input terminal
	27	CS6	—	ch.6 • Soft-start setting capacitor connection terminal
	29	OUT6	O	ch.6 • N-ch drive output terminal

(Continued)

(Continued)

Block name	Pin No.	Pin name	I/O	Description
OSC	12	CT	—	Triangular wave frequency setting capacitor connection terminal
	11	RT	—	Triangular wave frequency setting resistor connection terminal
Control	1	CTL	I	Power supply control terminal
	2	CTL1	I	ch.1 control terminal
	3	CTL2	I	ch.2 control terminal
	4	CTL3	I	ch.3 control terminal
	5	CTL4	I	ch.4 control terminal
	6	CTL5	I	ch.5 control terminal
	7	CTL6	I	ch.6 control terminal
	13	CSCP	—	Short-circuit detection circuit capacitor connection terminal
8	-INS	I	Short-circuit detection comparator inverted input terminal	
Power	36	VCCO	—	Drive output block power supply terminal
	48	VCC	—	Power supply terminal
	9	VREF	O	Reference voltage output terminal
	28	GNDO	—	Drive output block ground terminal
	10	GND	—	Ground terminal

MB39A123

■ BLOCK DIAGRAM

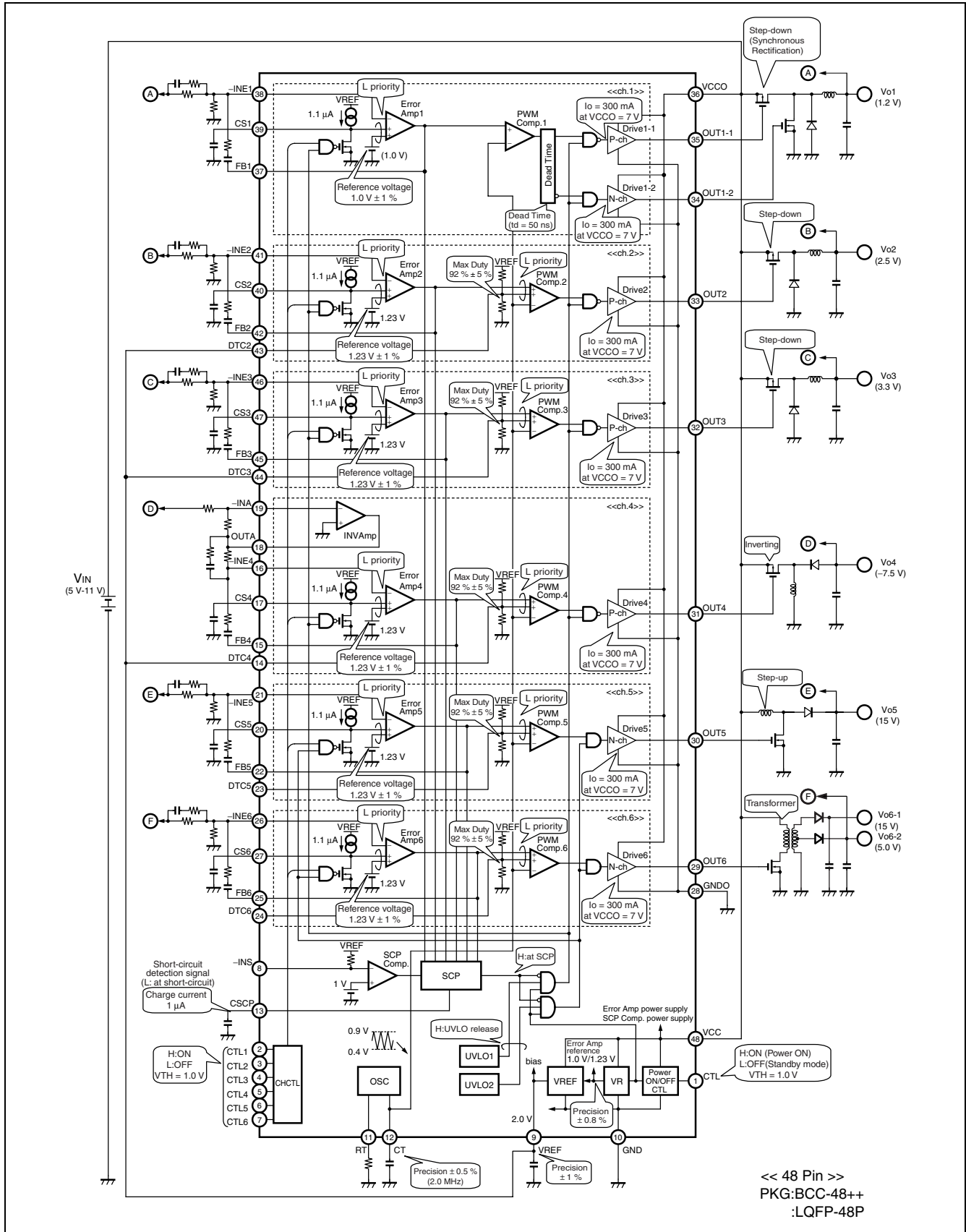

■ ABSOLUTE MAXIMUM RATINGS

Parameter	Symbol	Conditions	Rating		Unit
			Min	Max	
Power supply voltage	V _{CC}	VCC, VCCO terminals	—	12	V
Output current	I _O	OUT1-1, OUT1-2, OUT2 to OUT6 terminals	—	20	mA
Peak output current	I _{OP}	OUT1-1, OUT1-2, OUT2 to OUT6 terminals Duty ≤ 5%	—	400	mA
Power dissipation	P _D	T _a ≤ +25 °C (BCC-48++)	—	1670*	mW
		T _a ≤ +25 °C (LQFP-48P)	—	2000*	mW
Storage temperature	T _{STG}	—	-55	+125	°C

* : When mounted on a 117 mm × 84 mm × 0.8 mm FR-4 boards.

WARNING: Semiconductor devices can be permanently damaged by application of stress (voltage, current, temperature, etc.) in excess of absolute maximum ratings. Do not exceed these ratings.

■ RECOMMENDED OPERATING CONDITIONS

Parameter	Symbol	Conditions	Value			Unit
			Min	Typ	Max	
Start power supply voltage	V_{CC}	ch.5, ch.6, VCC, VCCO terminals	1.7	—	11	V
Power supply voltage	V_{CC}	VCC, VCCO terminals	2.5	4	11	V
Reference voltage output current	I_{REF}	VREF terminal	-1	—	0	mA
Input voltage	V_{INE}	-INE1 to -INE6 terminals	0	—	$V_{CC} - 0.9$	V
		-INA terminal	-0.2	—	$V_{CC} - 1.8$	V
		-INS terminal	0	—	V_{REF}	V
	V_{DTC}	DTC2 to DTC6 terminals	0	—	V_{REF}	V
Control input voltage	V_{CTL}	CTL, CTL1 to CTL6 terminals	0	—	11	V
Output current	I_o	OUT1-1, OUT1-2, OUT2 to OUT6 terminals	-15	—	+15	mA
Total gate charge of external FET	Q_g	OUT1-1, OUT1-2, OUT2 to OUT6 terminals connection FET $f_{osc} = 2 \text{ MHz}$	—	2.6	7.5	nC
Oscillation frequency	f_{osc}	—	0.2	1.0	2.0	MHz
Timing capacitor	C_T	—	27	100	680	pF
Timing resistor	R_T	—	3.0	6.8	39	k Ω
Soft-start capacitor	C_S	CS1 to CS6 terminals	—	0.1	1.0	μF
Short-circuit detection capacitor	C_{SCP}	—	—	0.1	1.0	μF
Reference voltage output capacitor	C_{REF}	—	—	0.1	1.0	μF
Operating ambient temperature	T_a	—	-30	+25	+85	$^{\circ}\text{C}$

WARNING: The recommended operating conditions are required in order to ensure the normal operation of the semiconductor device. All of the device's electrical characteristics are warranted when the device is operated within these ranges.

Always use semiconductor devices within their recommended operating condition ranges. Operation outside these ranges may adversely affect reliability and could result in device failure.

No warranty is made with respect to uses, operating conditions, or combinations not represented on the data sheet. Users considering application outside the listed conditions are advised to contact their FUJITSU representatives beforehand.

■ ELECTRICAL CHARACTERISTICS

(V_{CC} = V_{CCO} = 4 V, T_a = +25 °C)

Parameter	Symbol	Pin No.	Conditions	Value			Unit	
				Min	Typ	Max		
Reference Voltage Block [VREF]	Output voltage	V _{REF1}	9	VREF = 0 mA	1.98	2.00	2.02	V
		V _{REF2}	9	V _{CC} = 2.5 V to 11 V	1.975	2.000	2.025	V
		V _{REF3}	9	VREF = 0 mA to -1 mA	1.975	2.000	2.025	V
	Input stability	Line	9	V _{CC} = 2.5 V to 11 V*	—	2	—	mV
	Load stability	Load	9	VREF = 0 mA to -1 mA*	—	2	—	mV
	Temperature stability	$\Delta V_{REF}/V_{REF}$	9	T _a = 0 °C to +85 °C*	—	0.20	—	%
	Short-circuit output current	I _{OS}	9	VREF = 0 V*	—	-130	—	mA
Under voltage lockout protection circuit Block (ch.1 to ch.4) [UVLO1]	Threshold voltage	V _{TH1}	35	V _{CC} = \uparrow	1.7	1.8	1.9	V
	Hysteresis width	V _{H1}	35	—	0.05	0.1	0.2	V
	Reset voltage	V _{RST1}	35	V _{CC} = \downarrow	1.55	1.7	1.85	V
Under voltage lockout protection circuit Block (ch.5, ch.6) [UVLO2]	Threshold voltage	V _{TH2}	30	V _{CC} = \uparrow	1.35	1.5	1.65	V
	Hysteresis width	V _{H2}	30	—	0.02	0.05	0.1	V
	Reset voltage	V _{RST2}	30	V _{CC} = \downarrow	1.27	1.45	1.63	V
Short-circuit detection Block [SCP]	Threshold voltage	V _{TH}	13	—	0.65	0.70	0.75	V
	Input source current	I _{CS}	13	—	-1.4	-1.0	-0.6	μA
Triangular Wave Oscillator Block [OSC]	Oscillation frequency	f _{OSC1}	29 to 35	C _T = 100 pF, R _T = 6.8 kΩ	0.95	1.0	1.05	MHz
		f _{OSC2}	29 to 35	C _T = 100 pF, R _T = 6.8 kΩ V _{CC} = 2.5 V to 11 V	0.945	1.0	1.055	MHz
	Frequency Input stability	$\Delta f_{OSC}/f_{OSC}$	29 to 35	C _T = 100 pF, R _T = 6.8 kΩ V _{CC} = 2.5 V to 11 V*	—	1.0	—	%
	Frequency temperature stability	$\Delta f_{OSC}/f_{OSC}$	29 to 35	C _T = 100 pF, R _T = 6.8 kΩ T _a = 0 °C to +85 °C*	—	1.0	—	%
Soft-Start Block (ch.1 to ch.6) [CS1 to CS6]	Charge current	I _{CS}	17,20,27,39,40,47	CS1 to CS6 = 0 V	-1.45	-1.1	-0.75	μA

(Continued)

MB39A123

(VCC = VCCO = 4 V, Ta = +25 °C)

Parameter		Symbol	Pin No.	Conditions	Value			Unit
					Min	Typ	Max	
Error Amp Block (ch.1) [Error Amp1]	Reference voltage	V _{TH1}	38	V _{CC} = 2.5 V to 11 V Ta = +25 °C	0.990	1.000	1.010	V
		V _{TH2}	38	V _{CC} = 2.5 V to 11 V Ta = 0 °C to +85 °C*	0.988	1.000	1.012	V
	Temperature stability	$\Delta V_{TH}/V_{TH}$	38	Ta = 0 °C to +85 °C*	—	0.1	—	%
	Input bias current	I _B	38	-INE1 = 0 V	-120	-30	—	nA
	Voltage gain	A _v	37	DC*	—	100	—	dB
	Frequency bandwidth	BW	37	A _v = 0 dB*	—	1.4	—	MHz
	Output voltage	V _{OH}	37	—	1.7	1.9	—	V
		V _{OL}	37	—	—	40	200	mV
	Output source current	I _{SOURCE}	37	FB1 = 0.65 V	—	-2	-1	mA
Output sink current	I _{SINK}	37	FB1 = 0.65 V	150	200	—	μA	
Error Amp Block (ch.2 to ch.6) [Error Amp2 to Error Amp6]	Reference voltage	V _{TH3}	16, 21, 26, 41, 46	V _{CC} = 2.5 V to 11 V Ta = +25 °C	1.217	1.230	1.243	V
		V _{TH4}	16, 21, 26, 41, 46	V _{CC} = 2.5 V to 11 V Ta = 0 °C to +85 °C*	1.215	1.230	1.245	V
	Temperature stability	$\Delta V_{TH}/V_{TH}$	16, 21, 26, 41, 46	Ta = 0 °C to +85 °C*	—	0.1	—	%
	Input bias current	I _B	16, 21, 26, 41, 46	-INE2 to -INE6 = 0 V	-120	-30	—	nA
	Voltage gain	A _v	15, 22, 25, 42, 45	DC*	—	100	—	dB
	Frequency bandwidth	BW	15, 22, 25, 42, 45	A _v = 0 dB*	—	1.4	—	MHz
	Output voltage	V _{OH}	15, 22, 25, 42, 45	—	1.7	1.9	—	V
		V _{OL}	15, 22, 25, 42, 45	—	—	40	200	mV

(Continued)

(VCC = VCCO = 4 V, Ta = +25 °C)

Parameter		Symbol	Pin No.	Conditions	Value			Unit
					Min	Typ	Max	
Error Amp Block (ch.2 to ch.6) [Error Amp2 to Error Amp6]	Output source current	I _{SOURCE}	15, 22, 25, 42, 45	FB2 to FB6 = 0.65 V	—	-2	-1	mA
	Output sink current	I _{SINK}	15, 22, 25, 42, 45	FB2 to FB6 = 0.65 V	150	200	—	μA
Inverting Amp Block (ch.4) [Inv Amp]	Input offset voltage	V _{IO}	18	OUTA = 1.23V	-10	0	+10	mV
	Input bias current	I _B	19	- INA = 0V	-120	-30	—	nA
	Voltage gain	A _v	18	DC*	—	100	—	dB
	Frequency bandwidth	BW	18	A _v = 0 dB*	—	1.0	—	MHz
	Output voltage	V _{OH}	18	—	1.7	1.9	—	V
		V _{OL}	18	—	—	40	200	mV
	Output source current	I _{SOURCE}	18	OUTA = 1.23V	—	-2	-1	mA
Output sink current	I _{SINK}	18	OUTA = 1.23V	150	200	—	μA	
PWM Comparator Block (ch.1) [PWM Comp.1]	Threshold voltage	V _{T0}	34, 35	Duty cycle = 0%	0.35	0.4	0.45	V
		V _{T100}	34, 35	Duty cycle = 100%	0.85	0.9	0.95	V
PWM Comparator Block (ch.2 to ch.6) [PWM Comp.2 to PWM Comp.6]	Threshold voltage	V _{T0}	29 to 33	Duty cycle = 0%	0.35	0.4	0.45	V
		V _{T100}	29 to 33	Duty cycle = 100%	0.85	0.9	0.95	V
	Maximum duty cycle	D _{tr}	29 to 33	C _T = 100 pF, R _T = 6.8 kΩ	87	92	97	%
Output Block (ch.1 to ch.6) [Drive1 to Drive6]	Output source current	I _{SOURCE}	29 to 35	Duty ≤ 5% OUT = 0 V	—	-130	-75	mA
	Output sink current	I _{SINK}	29 to 35	Duty ≤ 5% OUT = 4 V	75	130	—	mA
	Output on resistor	R _{OH}	29 to 35	OUT = -15 mA	—	18	27	Ω
		R _{OL}	29 to 35	OUT = 15 mA	—	18	27	Ω
	Dead time	t _{D1}	34, 35	OUT2 $\overline{\downarrow}$ - OUT1 $\overline{\downarrow}$ *	—	50	—	ns
t _{D2}		34, 35	OUT1 $\overline{\downarrow}$ - OUT2 $\overline{\downarrow}$ *	—	50	—	ns	

(Continued)

MB39A123

(Continued)

(VCC = VCCO = 4 V, Ta = +25 °C)

Parameter		Symbol	Pin No.	Conditions	Value			Unit
					Min	Typ	Max	
Short-Circuit Detection Comparator Block [SCP Comp.]	Threshold voltage	V_{TH}	35	—	0.97	1.00	1.03	V
	Input bias current	I_B	8	$-INS = 0 V$	-25	-20	-17	μA
Control Block (CTL, CTL1 to CTL6) [CTL, CHCTL]	Output on condition	V_{IH}	1 to 7	CTL, CTL1 to CTL6	1.5	—	11	V
	Output off condition	V_{IL}	1 to 7	CTL, CTL1 to CTL6	0	—	0.5	V
	Input current	I_{CTLH}	1 to 7	CTL, CTL1 to CTL6 = 3 V	5	30	60	μA
		$I_{CTL L}$	1 to 7	CTL, CTL1 to CTL6 = 0 V	—	—	1	μA
General	Standby current	I_{CCS}	48	CTL, CTL1 to CTL6 = 0 V	—	0	2	μA
		I_{CCSO}	36	CTL = 0 V	—	0	1	μA
	Power supply current	I_{CC}	48	CTL = 3 V	—	4.5	6.8	mA

* : Standard design value

■ TYPICAL CHARACTERISTICS

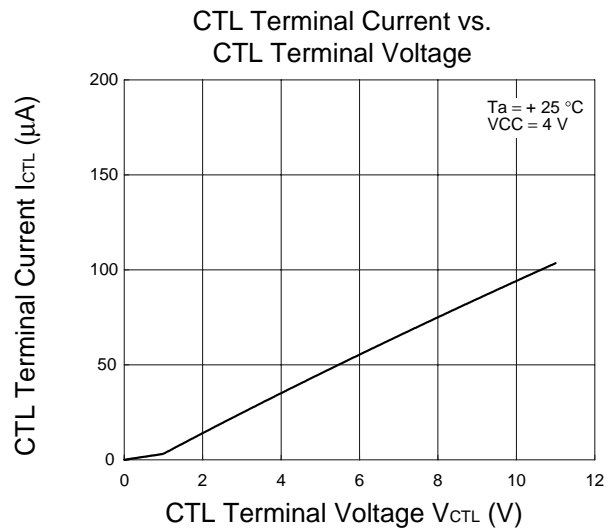
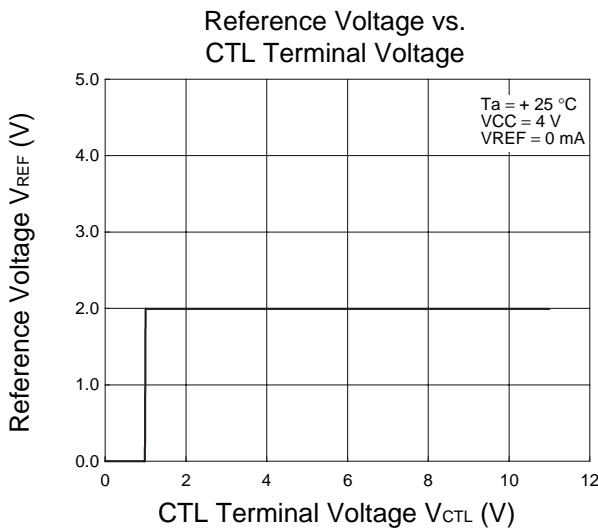
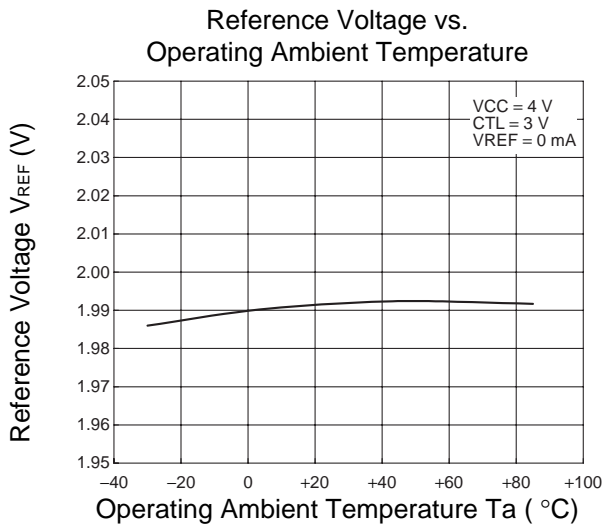
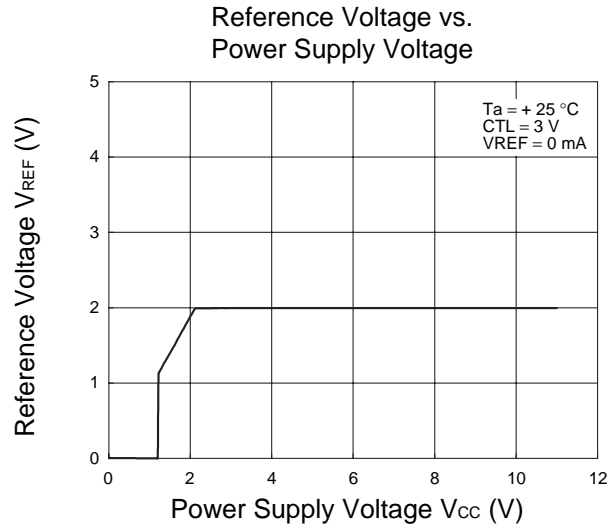
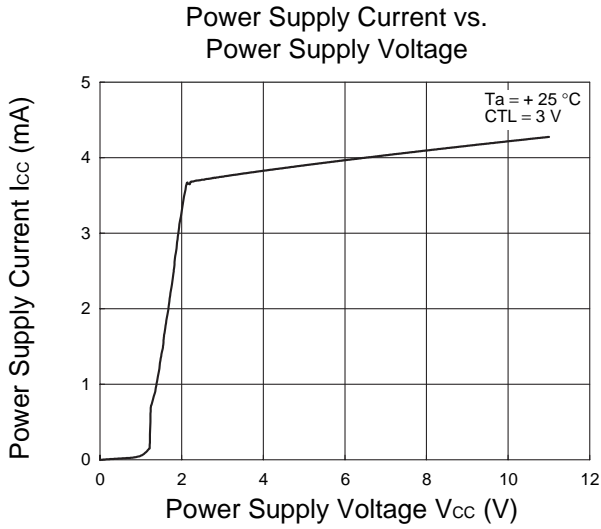

(Continued)

Triangular Wave Oscillation Frequency vs. Timing Resistor

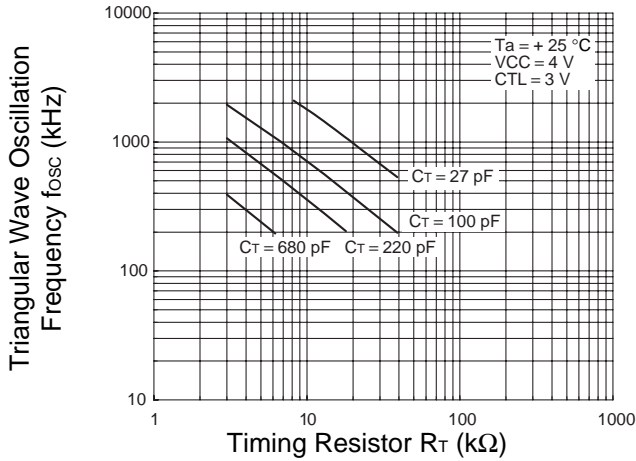

Triangular Wave Oscillation Frequency vs. Timing Capacity

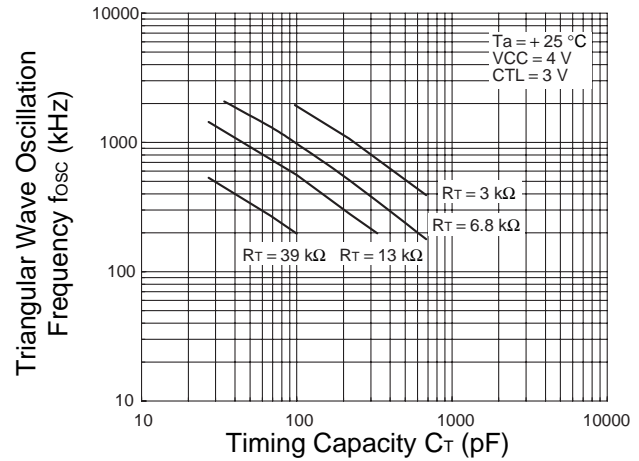

Triangular Wave Upper and Lower Limit Voltage vs. Triangular Wave Oscillation Frequency

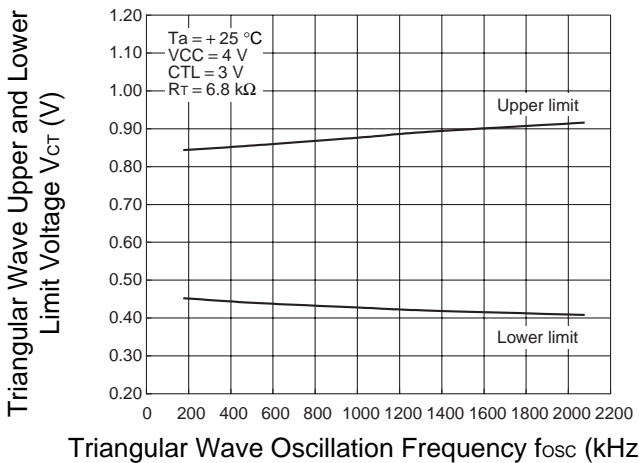

Triangular Wave Upper and Lower Limit Voltage vs. Operating Ambient Temperature

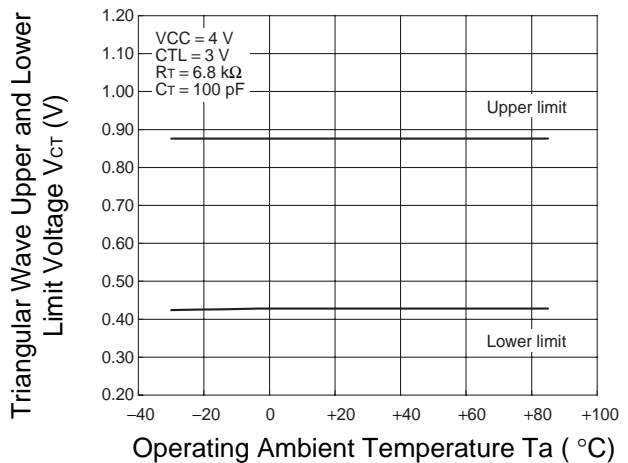

Triangular Wave Oscillation Frequency vs. Operating Ambient Temperature

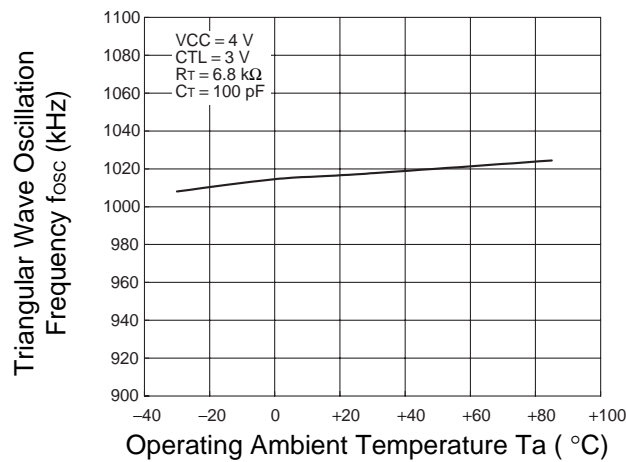

(Continued)

ON Duty Cycle vs. DTC Terminal Voltage

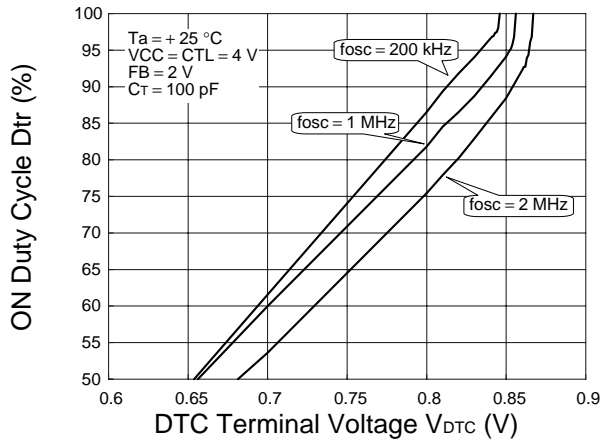

Maximum Duty Cycle vs. Oscillation Frequency

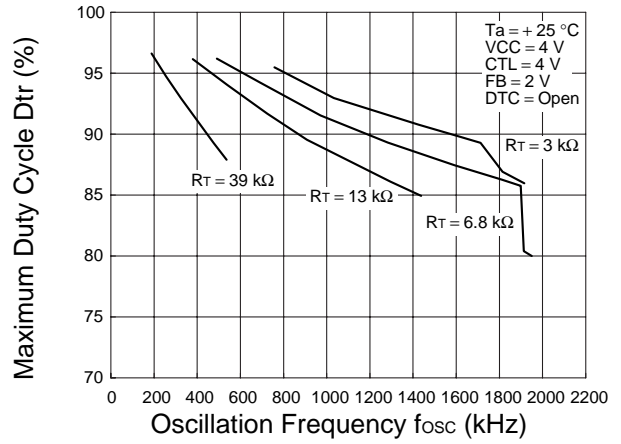

Maximum Duty Cycle vs. Power Supply Voltage

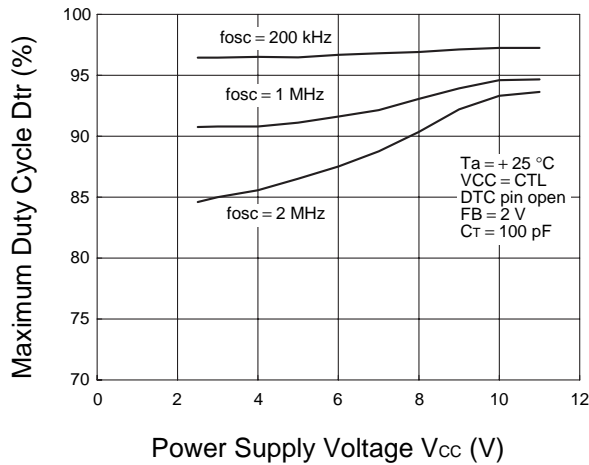

Maximum Duty Cycle vs. Operating Ambient Temperature

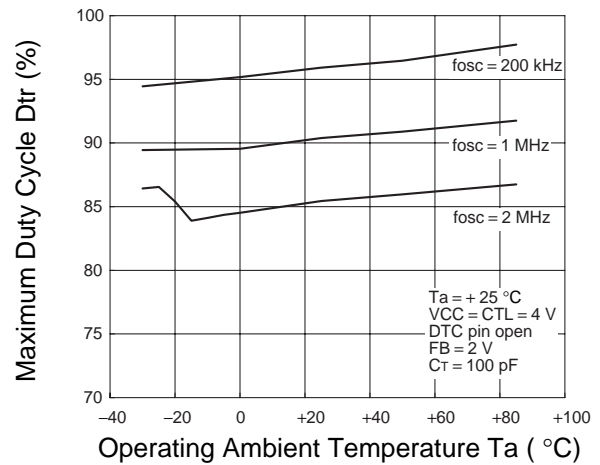

Start Power Supply Voltage vs. Timing Resistor

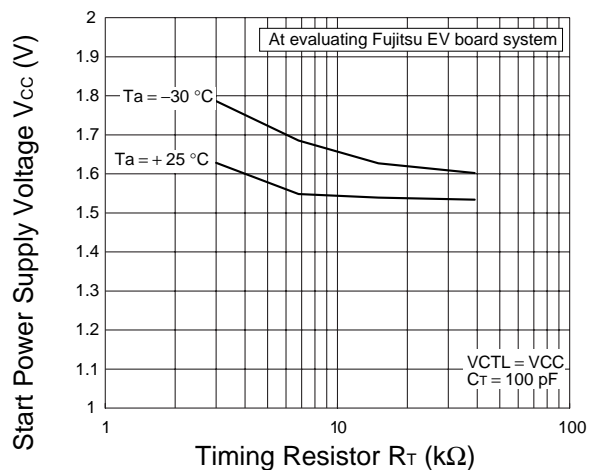

(Continued)

MB39A123

(Continued)

Error Amp Voltage Gain, Phase vs. Frequency

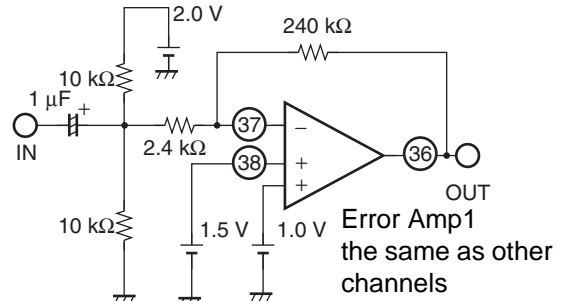
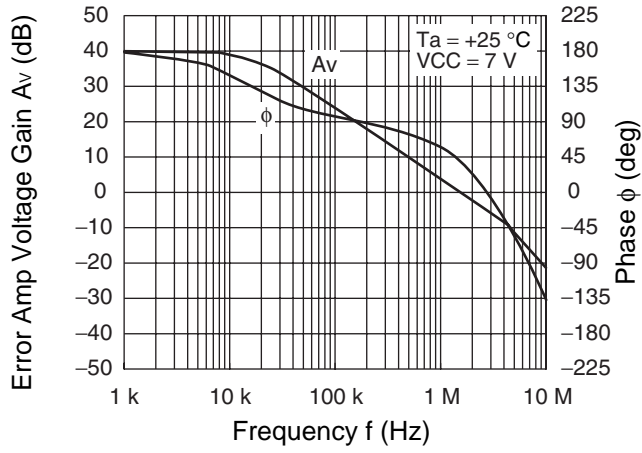

Maximum Power Dissipation vs. Operating Ambient Temperature (for BCC-48++)

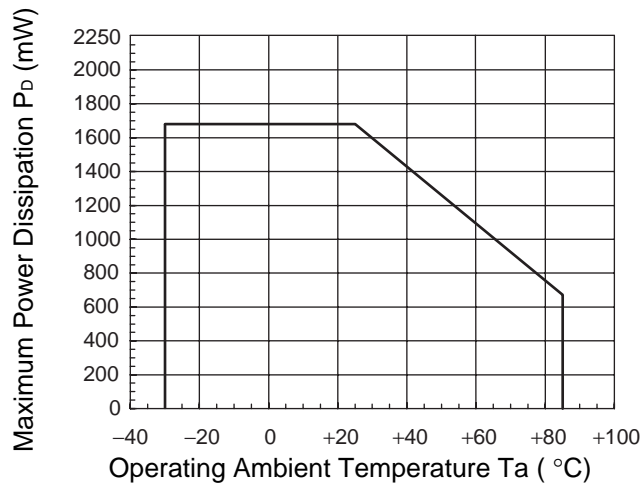

Maximum Power Dissipation vs. Operating Ambient Temperature (for LQFP-48P)

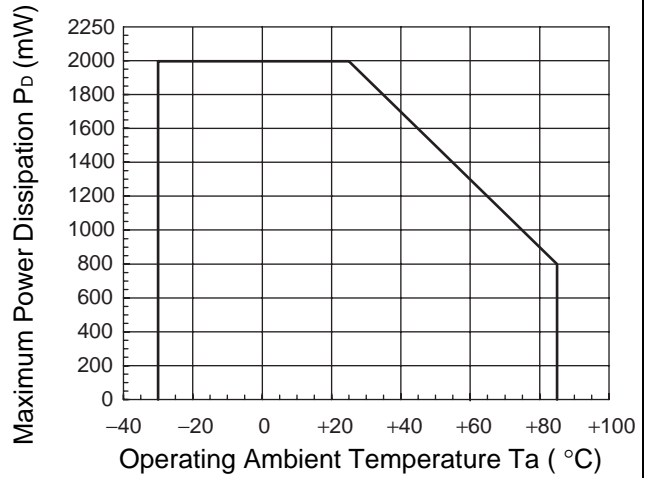

■ FUNCTIONAL DESCRIPTION

1. DC/DC Converter Function

(1) Reference voltage block (VREF)

The reference voltage circuit uses the voltage supplied from VCC terminal (pin 48) to generate a temperature compensated reference voltage (2.0 V Typ) used as the reference voltage for the internal circuits of the IC. It is also possible to supply the load current of up to 1 mA to external circuits as a reference voltage through the VREF terminal (pin 9) .

(2) Triangular wave oscillator block (OSC)

The triangular wave oscillator block generates the triangular wave oscillation waveform width of 0.4 V lower limit and 0.5 V amplitude by the timing resistor (R_T) connected to the RT terminal (pin 11) , and the timing capacitor (C_T) connected to the CT terminal (pin 12) . The triangular wave is input to the PWM comparator circuits on the IC.

(3) Error amplifier block (Error Amp1 to Error Amp6)

The error amplifier detects output voltage of the DC/DC converter and outputs PWM control signals. An arbitrary loop gain can be set by connecting a feedback resistor and capacitor from the output terminal to inverted input terminal of the error amplifier, enabling stable phase compensation for the system.

You can prevent surge currents when the IC is turned on by connecting soft-start capacitors to the CS1 terminal (pin 39) to CS6 terminal (pin 27) which are the noninverting input terminals of the error amplifier. The IC is started up at constant soft-start time intervals independent of the output load of the DC/DC converter.

(4) PWM comparator block (PWM Comp.1 to PWM Comp.6)

The PWM comparator block is a voltage-pulse width converter that controls the output duty depending on the input/output voltage.

An output transistor is turned on, during intervals when the error amplifier output voltage and DTC voltage (ch.2 to ch.6) are higher than the triangular wave voltage.

(5) Output block (Drive1 to Drive6)

The output circuit uses a totem-pole configuration and is capable of driving an external P-ch MOS FET (main side of ch.1, ch.2, ch.3 and ch.4) and N-ch MOS FET (synchronous rectification side of ch.1, ch.5 and ch.6).

MB39A123

2. Channel Control Function

Use the CTL terminal (pin 1), CTL1 terminal (pin 2), CTL2 terminal (pin 3), CTL3 terminal (pin 4), CTL4 terminal (pin 5), CTL5 terminal (pin 6), and CTL6 terminal (pin 7) to set ON/OFF to the main and each channels.

ON/OFF setting conditions for each channel

CTL	CTL1	CTL2	CTL3	CTL4	CTL5	CTL6	Power	ch.1	ch.2	ch.3	ch.4	ch.5	ch.6
L	X	X	X	X	X	X	OFF	OFF	OFF	OFF	OFF	OFF	OFF
H	L	L	L	L	L	L	ON	OFF	OFF	OFF	OFF	OFF	OFF
H	H	L	L	L	L	L	ON	ON	OFF	OFF	OFF	OFF	OFF
H	L	H	L	L	L	L	ON	OFF	ON	OFF	OFF	OFF	OFF
H	L	L	H	L	L	L	ON	OFF	OFF	ON	OFF	OFF	OFF
H	L	L	L	H	L	L	ON	OFF	OFF	OFF	ON	OFF	OFF
H	L	L	L	L	H	L	ON	OFF	OFF	OFF	OFF	ON	OFF
H	L	L	L	L	L	H	ON	OFF	OFF	OFF	OFF	OFF	ON
H	H	H	H	H	H	H	ON	ON	ON	ON	ON	ON	ON

Note : Note that current which is over standby current flows into VCC terminal when the CTL terminal is in “L” level and one of the terminals between CTL1 to CTL6 terminals is set to “H” level.
(Refer to the following circuit)

- CTL1 to CTL6 terminals equivalent circuit

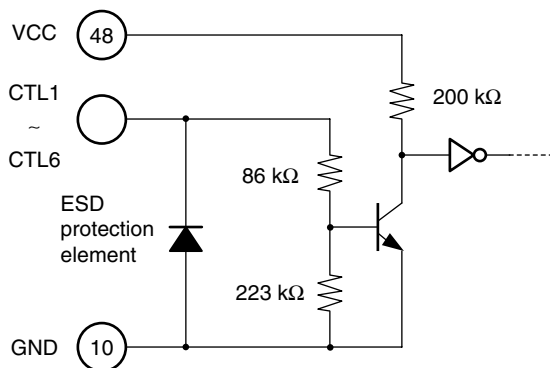

3. Protection Function

(1) Timer-latch short-circuit protection circuit (SCP, SCP Comp.)

The short-circuit detection comparator (SCP) detects the output voltage level of each channel. If the output voltage of any channel is lower than the short-circuit detection voltage, the timer circuit is actuated to start charging to the capacitor (Cscp) externally connected to the CSCP terminal (pin 13).

When the capacitor (Cscp) voltage becomes about 0.7 V, the output transistor is turned off and the dead time is set to 100%.

The short-circuit detection from external input is capable by using –INS terminal (pin 8) on short-circuit detection comparator (SCP Comp.) .

When the protection circuit is actuated, the power supply is rebooted or the CTL terminal (pin 1) is set to "L" level, resetting the latch as the voltage at the VREF terminal (pin 9) becomes 1.27 V (Min) or less (Refer to "■SETTING THE TIME CONSTANT FOR TIMER-LATCH SHORT-CIRCUIT PROTECTION CIRCUIT") .

(2) Under voltage lockout protection circuit block (UVLO)

The transient state or a momentary decrease in the power supply voltage, which occurs when the power supply is turned on, may cause the control IC to malfunction, resulting in the breakdown or degradation of the system. To prevent such malfunctions, under voltage lockout protection circuit detects a decrease in internal reference voltage level with respect to the power supply voltage, turns off the output transistor, and sets the dead time to 100% while holding the CSCP terminal (pin 13) at the "L" level.

The system returns to the normal state when the power supply voltage reaches the reference voltage of the under voltage lockout protection circuit.

(3) Protection circuit operating function table

The following table shows the output state that the protection circuit is operating.

Operation circuit	OUT1-1	OUT1-2	OUT2	OUT3	OUT4	OUT5	OUT6
Short-circuit protection circuit	H	L	H	H	H	L	L
Under voltage lockout protection circuit	H	L	H	H	H	L	L

■ SETTING THE OUTPUT VOLTAGE

• ch.1

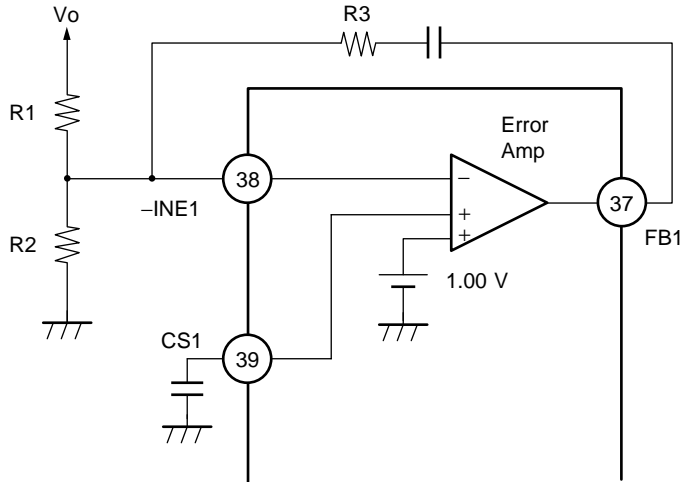

$$V_o = \frac{1.00 \text{ V}}{R_2} (R_1 + R_2)$$

$$(R_1 + R_3) \geq \frac{V_o}{100 \mu\text{A}}$$

Set R1 and R3 to prevent the error amp's response from decreasing by using above formula.

• ch.2 to ch.6

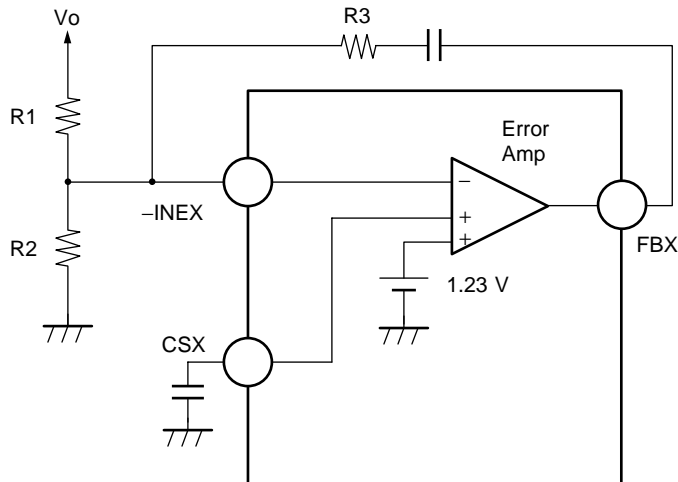

$$V_o = \frac{1.23 \text{ V}}{R_2} (R_1 + R_2)$$

$$(R_1 + R_3) \geq \frac{V_o}{100 \mu\text{A}}$$

X : Each channel number

Set R1 and R3 to prevent the error amp's response from decreasing by using above formula.

- ch.4 (Negative voltage output)

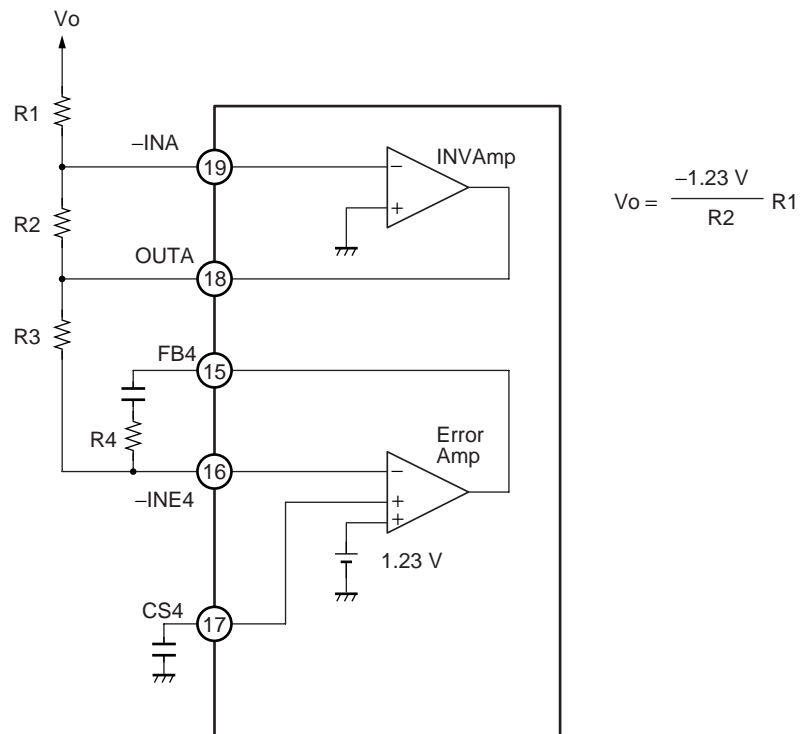

■ SETTING THE TRIANGULAR WAVE OSCILLATION FREQUENCY

The triangular wave oscillation frequency can be set by connecting a timing resistor (R_T) to the RT terminal (pin 11) and a timing capacitor (C_T) to the CT terminal (pin 12).

Triangular wave oscillation frequency : f_{osc}

$$f_{osc} \text{ (kHz)} \doteq \frac{680000}{C_T \text{ (pF)} \times R_T \text{ (k}\Omega\text{)}}$$

■ SETTING THE SOFT-START TIME

To prevent rush currents when the IC is turned on, you can set a soft-start by connecting soft-start capacitors (C_{S1} to C_{S6}) to the CS1 terminal (pin 39) to CS6 terminal (pin 27) respectively.

As illustrated below, when each CTLX is set to "H" from "L", the soft-start capacitors (C_{S1} to C_{S6}) externally connected to the CS1 to CS6 terminals are charged at about 1.1 μA .

The error amplifier output (FB1 to FB6) is determined by comparison between the lower voltage of the two non-inverted input terminal voltage (1.23 V (ch.1 : 1.0 V), CS terminal voltage) and the inverted input terminal voltage ($-\text{INE1}$ to $-\text{INE6}$). The FB terminal voltage is decided for the soft-start period (CS terminal voltage < 1.23 V (ch.1 : 1.0 V)) by the comparison between $-\text{INE}$ terminal voltage and CS terminal voltage. The DC/DC converter output voltage rises in proportion to the CS terminal voltage as the soft-start capacitor externally connected to the CS terminal is charged. The soft-start time is obtained from the following formula :

Soft-start time : t_s (time until output voltage 100%)

ch.1 : t_s (s) $\approx 0.91 \times C_{S1}$ (μF)

ch.2 to ch.6 : t_s (s) $\approx 1.12 \times C_{Sx}$ (μF) X : Each channel number

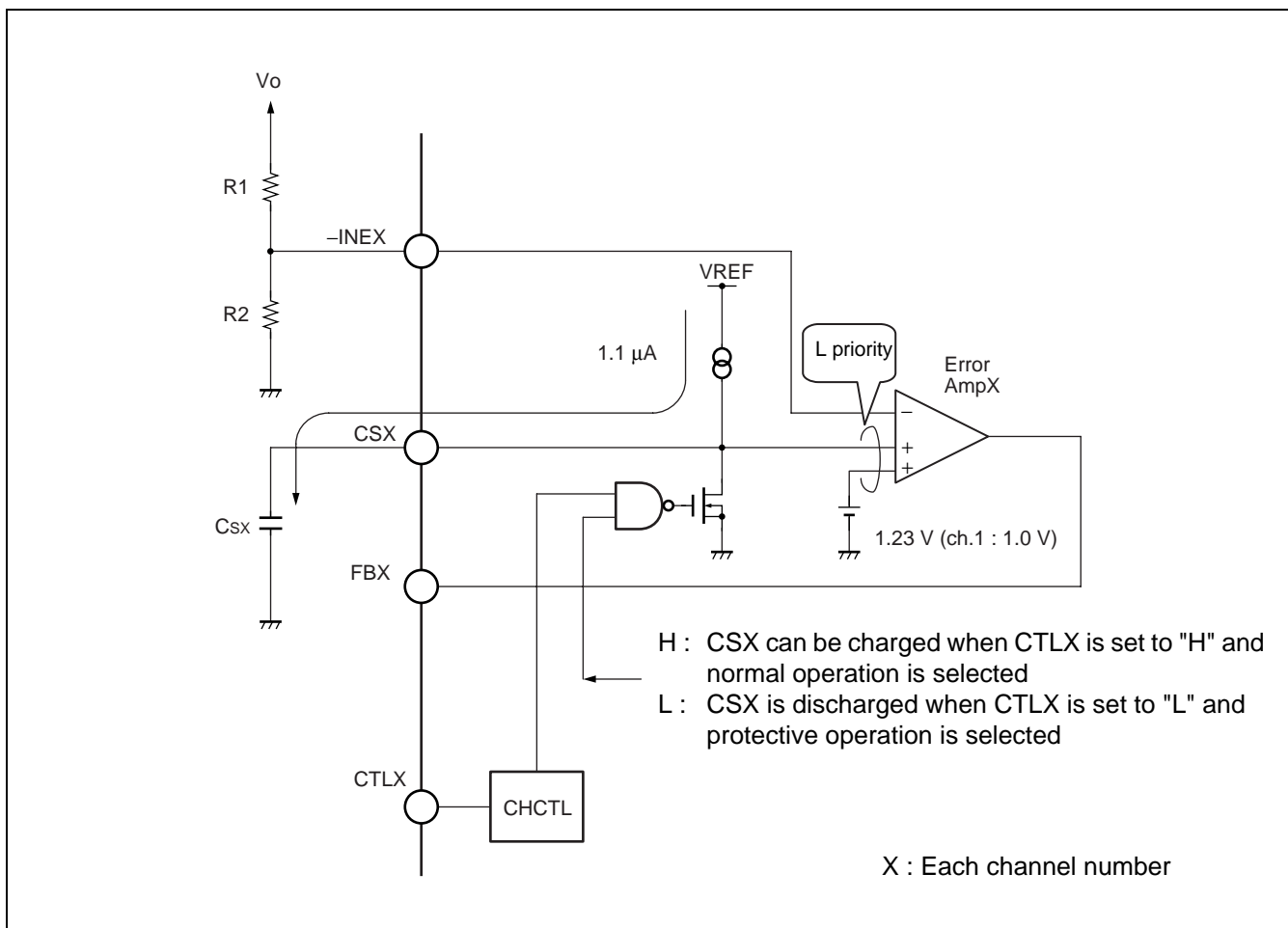

MB39A123

■ PROCESSING WHEN NOT USING CS TERMINAL

When soft-start function is not used, leave the CS1 terminal (pin 39), the CS2 terminal (pin 40), the CS3 terminal (pin 47), the CS4 terminal (pin 17), the CS5 terminal (pin 20) and the CS6 terminal (pin 27) open.

- When not setting soft-start time

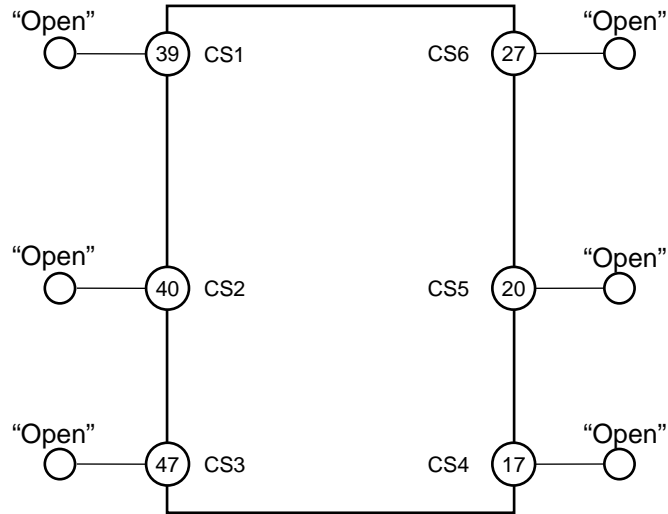

■ SETTING THE TIME CONSTANT FOR TIMER-LATCH SHORT-CIRCUIT PROTECTION CIRCUIT

Each channel uses the short-circuit detection comparator (SCP) to always compare the error amplifier's output level to the reference voltage.

While DC/DC converter load conditions are stable on all channels, the short-circuit detection comparator output remains at "L" level, and the CSCP terminal (pin 13) is held at "L" level.

If the load condition on a channel changes rapidly due to a short-circuit of the load, causing the output voltage to drop, the output of the short-circuit detection comparator on that channel goes to "H" level.

This causes the external short-circuit protection capacitor C_{SCP} connected to the CSCP terminal (pin 13) to be charged at 1 μ A.

Short-circuit detection time : t_{CSCP}

$$t_{CSCP} \text{ (s)} \cong 0.70 \times C_{SCP} \text{ (\mu F)}$$

When the capacitor C_{SCP} is charged to the threshold voltage ($V_{TH} \cong 0.70 \text{ V}$), the latch is set to and the external FET is turned off (dead time is set to 100%). At this time, the latch input is closed and CSCP terminal (pin 13) is held at "L" level.

The short-circuit detection from external input is capable by using $-INS$ terminal (pin 8). In this case, the short-circuit detection operates when the $-INS$ terminal voltage becomes the level of the threshold voltage ($V_{TH} \cong IV$) or less.

Note that the latch is reset as the voltage at the VREF terminal (pin 9) is decreased to 1.27 V (Min) or less by either recycling the power supply or setting the CTL terminal (pin 1) to "L" level.

• Timer-latch short-circuit protection circuit

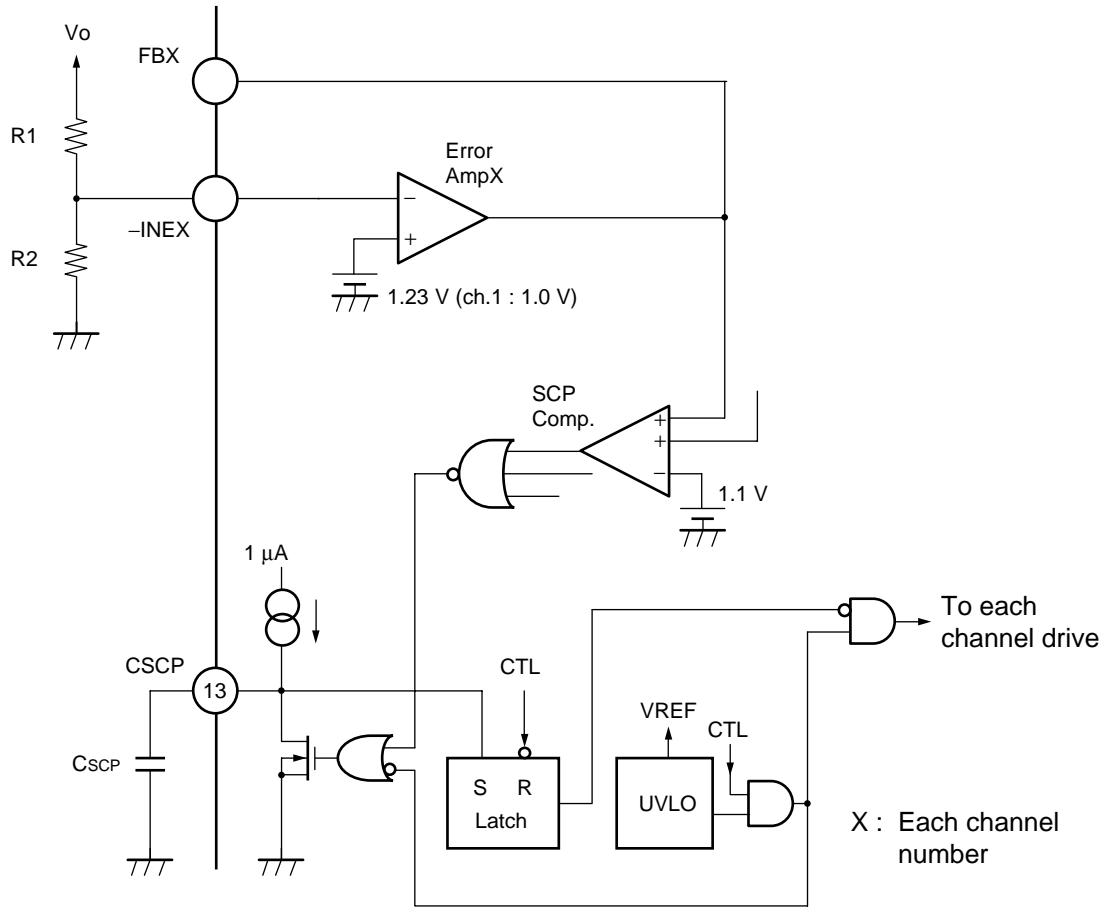

■ PROCESSING WHEN NOT USING CSCP TERMINAL

To disable the timer-latch short-circuit protection circuit, connect the CSCP terminal (pin 13) to GND in the shortest distance.

- Processing when not using the CSCP terminal

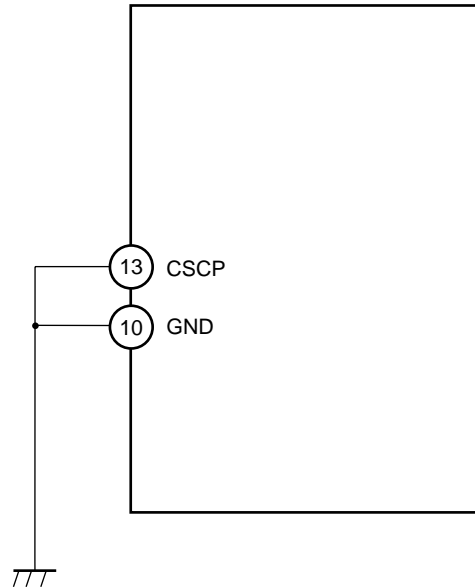

■ SETTING THE DEAD TIME (ch.2 to ch.6)

When the device is set for step-up or inverted output based on the step-up, step-up/down Zeta method, step up/down Sepic method, or flyback method, the FB terminal voltage may reach and exceed the triangular wave voltage due to load fluctuation. If this is the case, the output transistor is fixed to a full-ON state (ON duty = 100%). To prevent this, set the maximum duty of the output transistor.

When the DTC terminal is opened, the maximum duty is 92% (Typ) because of this IC built-in resistor which sets the DTC terminal voltage. This is based on the following setting: 1MHz ($R_T = 6.8k\Omega/C_T = 100pF$).

To disable the DTC terminal, connect it to the VREF terminal (pin 9) as illustrated below (when dead time is not set).

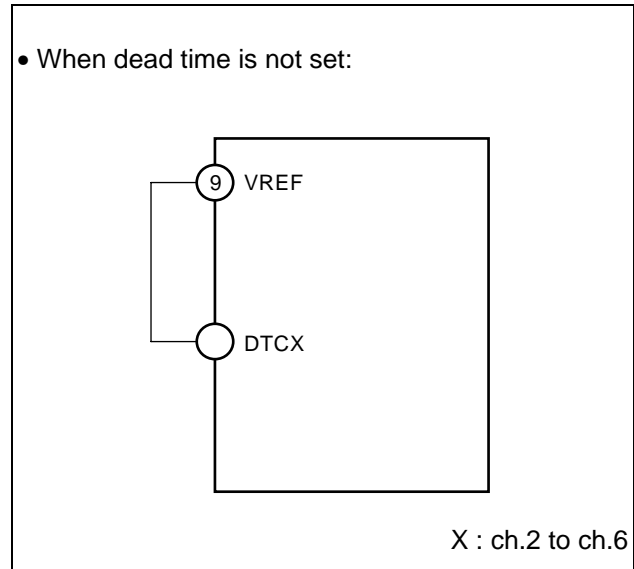
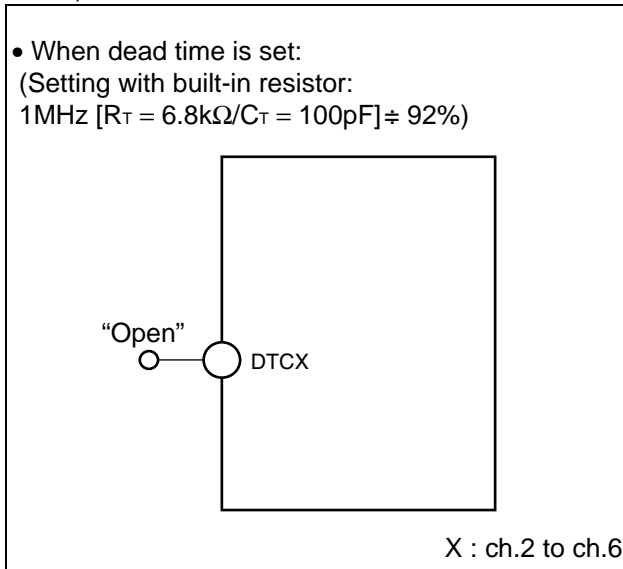

To change the maximum duty using external resistors, set the DTC terminal voltage by dividing resistance using the VREF voltage. Refer to “• When dead time is set : (Setting by external resistors)”.

It is possible to set without regard for the built-in resistance value (including tolerance) when setting the external resistance value to 1/10 of the built-in resistance or less.

Note that the VREF load current must be set such that the total current for all the channels does not exceed 1 mA.

When the DTC terminal voltage is higher than the triangular wave voltage, the output transistor is turned on. The formula for calculating the maximum duty is as follows, assuming that the triangular wave amplitude and triangular wave lower limit voltage are about 0.5 V and 0.4 V, respectively.

$$\text{DUTY (ON) Max} \approx \frac{V_{dt} - 0.4 \text{ V}}{0.5 \text{ V}} \times 100 (\%)$$

$$V_{dt} = \frac{R_b}{R_a + R_b} \times V_{REF} (\text{V}) \quad \left(\text{condition : } R_a < \frac{R_1}{10}, R_b < \frac{R_2}{10} \right)$$

Note : DUTY obtained by the above-mentioned formula is a calculated value. For setting, refer to “ON Duty cycle vs. DTC terminal voltage”.

The maximum duty varies depending on the oscillation frequency, regardless of settings in built-in or external resistors.

(This is due to the dependency of the peak value of a triangular wave on the oscillation frequency and R_T . Therefore, if R_T is greater, the maximum duty decreases, even when the same frequency is used.)

Furthermore, the maximum duty increases when the power supply voltage and the temperature are high. It is therefore recommended to set the duty, based on the "■ TYPICAL CHARACTERISTICS" data, so that it does not exceed 95% under the worst conditions.

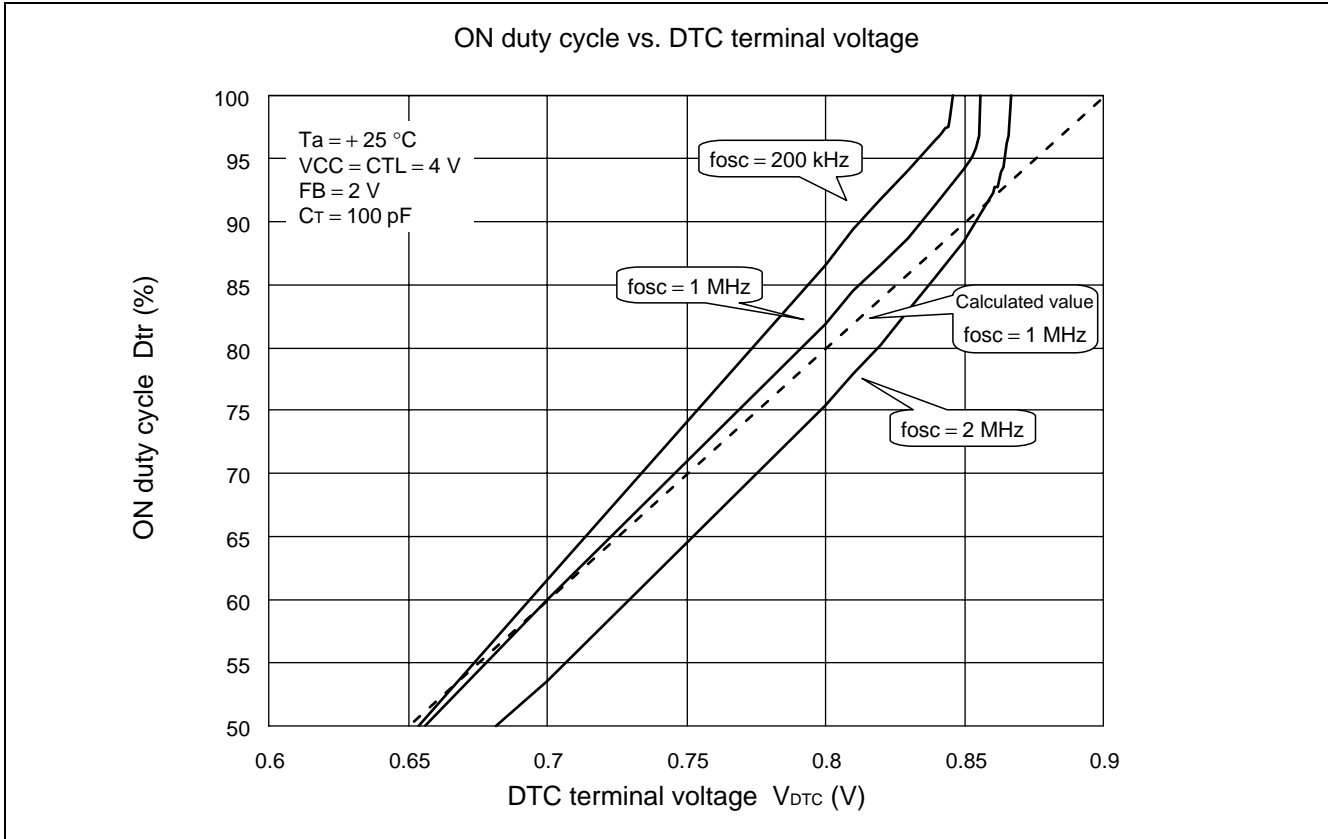

- When dead time is set (Setting by external resistors)

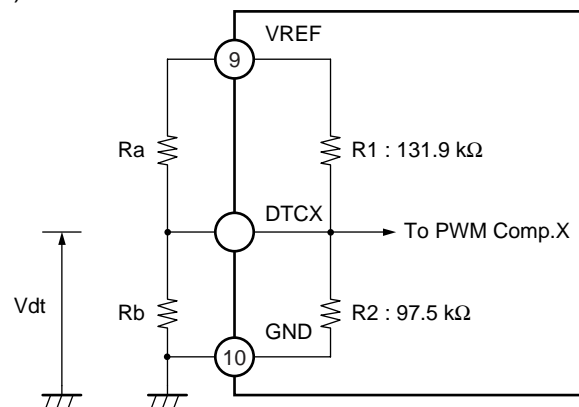

X: ch.2 to ch.6

MB39A123

Setting example (for an aim maximum ON duty of 80% ($V_{dt} = 0.8 \text{ V}$) with $R_a = 13.7 \text{ k}\Omega$ and $R_b = 9.1 \text{ k}\Omega$)

- Calculation using external resistors R_a and R_b only

$$V_{dt} = \frac{R_b}{R_a + R_b} \times V_{REF} \approx 0.80 \text{ V}$$

$$\text{DUTY (ON) Max} \approx \frac{V_{dt} - 0.4 \text{ V}}{0.5 \text{ V}} \times 100 (\%) \approx 80\% \dots \dots (1)$$

- Calculation taking account of the built-in resistor (tolerance $\pm 20\%$) also

$$V_{dt} = \frac{(\text{Rb, R2 Combined resistance})}{(\text{Ra, R1 Combined resistance}) + (\text{Rb, R2 Combined resistance})} \times V_{REF} \approx 0.80 \text{ V} \pm 0.13\%$$

$$\text{DUTY (ON) Max} \approx \frac{V_{dt} - 0.4 \text{ V}}{0.5 \text{ V}} \times 100 (\%) \approx 80\% \pm 0.2\% \dots \dots (2)$$

Based on (1) and (2) above, selecting external resistances to 1/10th or less of the built-in resistance enables the built-in resistance to be ignored.

As for the duty dispersion, please expect $\pm 5\%$ at ($f_{osc} = 1 \text{ MHz}$) due to the dispersion of a triangular wave amplitude.

■ PROCESSING WHEN NOT USING ch.4 INV AMP

Short-circuit the - INA terminal (pin 19) and OUTA terminal (pin 18) in the shortest distance when not using ch.4 INV Amp.

- When not using ch.4 INV Amp

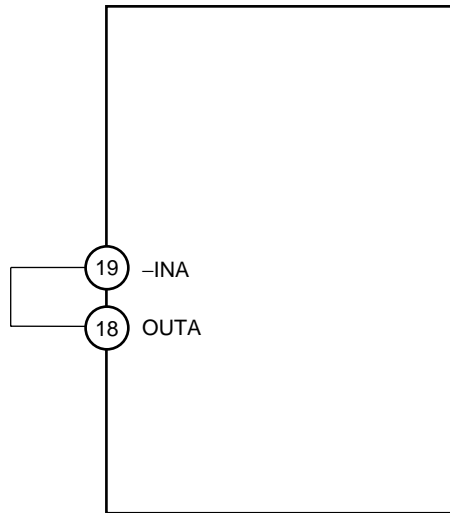

■ OPERATION EXPLANATION WHEN CTL TURNING ON AND OFF

When CTL is turned on, internal reference voltage VR and VREF generate. When VREF exceeds each threshold voltage (VTH) of UVLO (under voltage lockout protection circuit), UVLO is released, and the operation of output drive circuit of each channel becomes possible.

When CTL is off, the CS and CSCP terminals are always set to "L" as soon as output drive circuit of each channel is fixed to full off even if UVLO is released. When VR and VREF fall and VREF decreases the threshold voltage (VRST) of UVLO (under voltage lockout protection circuit), output drive circuit becomes the UVLO state.

• CTL block equivalent circuit

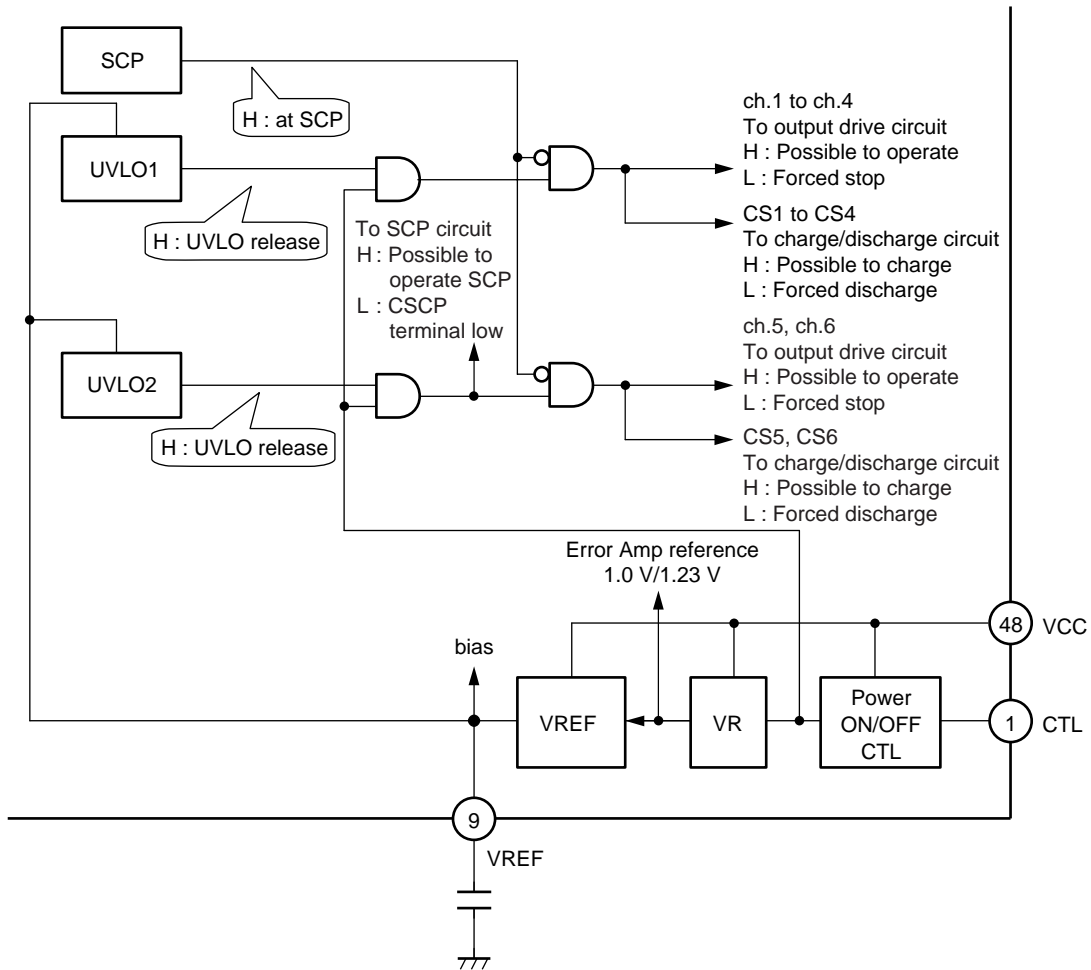

• Operation waveform when CTL turning on and off

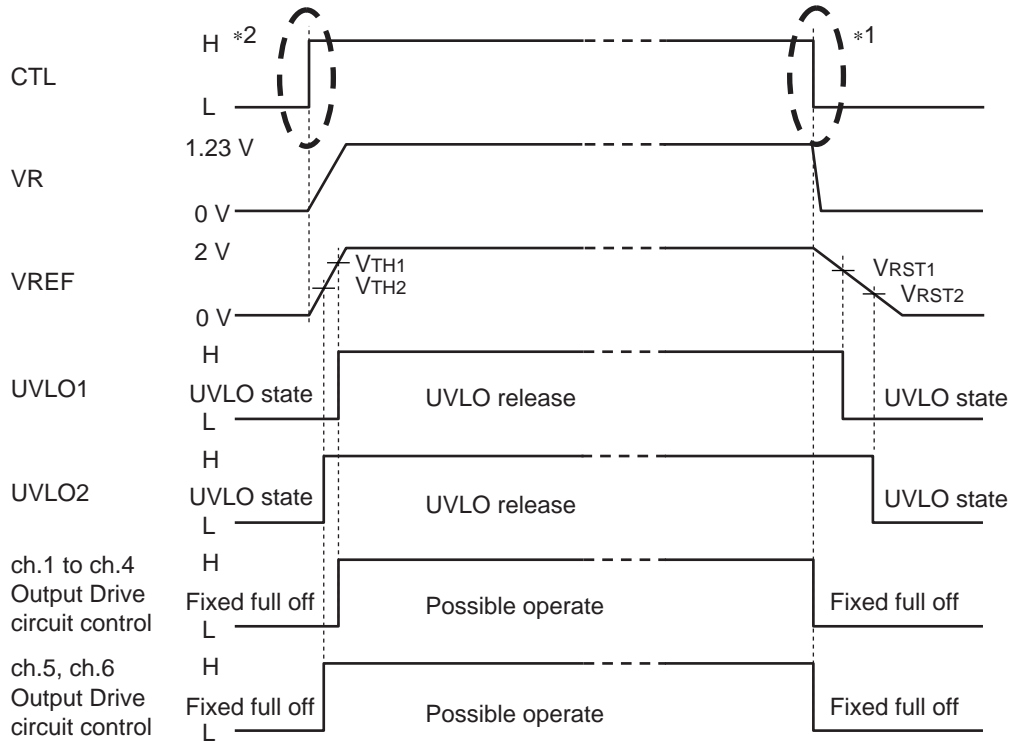

*1 : As shown in the sequence on the above figure, when turning off CTL while each CHCTL is turned on, intermission state may be generated due to noise around the CTL threshold voltage. To prevent this, it is recommended to turn off CTL with a slope of $-1\text{ V}/50\text{ }\mu\text{s}$ or higher so that the CTL voltage does not remain in the specified threshold voltage range (0.5 V to 1.5 V) . If the above slope setting is difficult to achieve, it is recommended to turn off CTL after turning off all CHCTLs.

Moreover, a voltage remains in the FB terminal, when VCC is turned off at the same time as CTL and CHCTL, or when VCC is turned off at the same time as CTL while each CHCTL is still turned on. As this may lead to an overshoot upon restart, it is recommended to turn off V_{IN} and CTL after turning off all the CHCTLs to reduce FB to 0V.

Likewise, it is recommended to turn off CHCTL with a slope of $-1\text{ V}/50\text{ }\mu\text{s}$ or higher.

*2 : When CTL and CHCTL are turned on at the same time, or when CTL is turned on while each CHCTL is turned on, there exists a period (approx. 200 ns) when the error Amp output voltage (FB) is higher than the triangular wave voltage (CT) upon the startup of VREF. As a result, when UVLO is released and then the Output Drive circuit of each channel becomes operable, the output transistor is turned on, generating a voltage at the DC/DC converter output.

The voltage to be generated (V_{op}) depends on L, Co and V_{IN} . (See • V_o characteristics (V_{op}) when turning on CTL at CHCTL ON.)

It should be noted that the above event does not occur when CTL is turned on while CHCTL is turned off. Therefore, it is recommended to turn on each CHCTL after turning on CTL.

- Vo characteristics (Vop) when turning on CTL at CHCTL ON

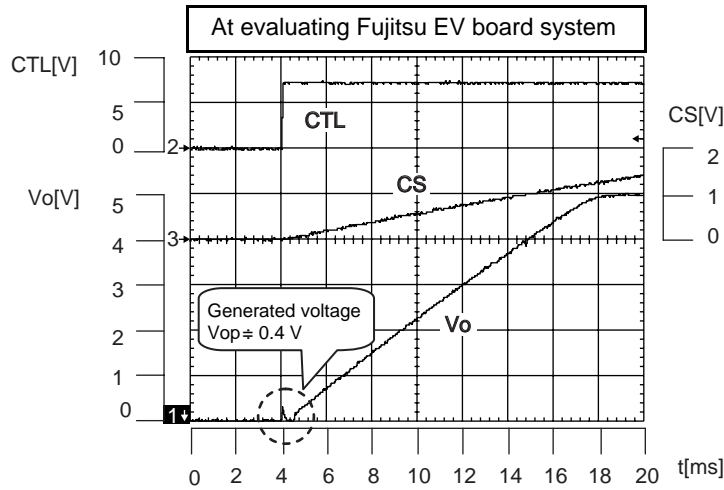

Step-down operation

$V_{IN} = 7.2\text{ V}$

$V_o = 5\text{ V}$

$L = 15\ \mu\text{H}$

$C_o = 2.2\ \mu\text{F}$

Load = $50\ \Omega$

CHCTL = ON

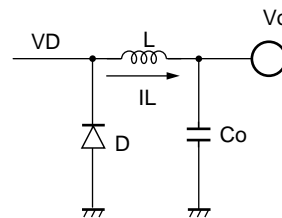

Generated output voltage - Output capacitor value

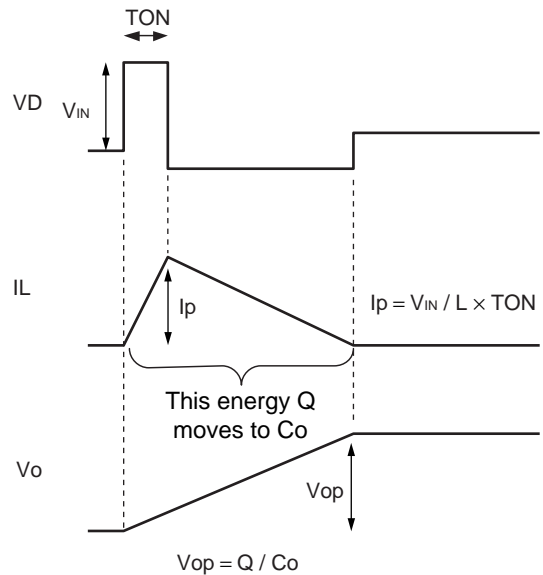
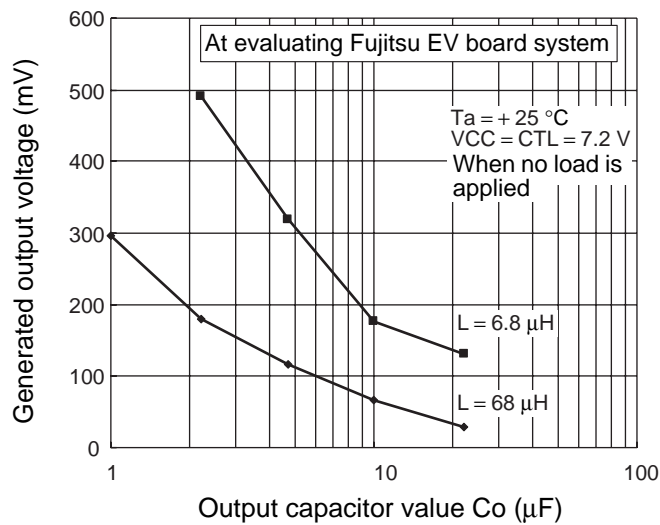

■ ABOUT THE LOW VOLTAGE OPERATION

1.7 V or more is necessary for the VCC terminal (pin 48) and the VCCO terminal (pin 36) for the self-power supply type to use the step-up circuit as the start voltage.

Even if thereafter V_{IN} voltage decreases to 1.5 V, operation is possible if the VCC terminal (pin 48) voltage and the VCCO terminal (pin 36) voltage rise to 2.5 V or more after start-up. However, it is necessary not to exceed the maximum duty set value by the duty due to the V_{IN} decrease. Including other channels, execute an enough operation margin confirmation when using it.

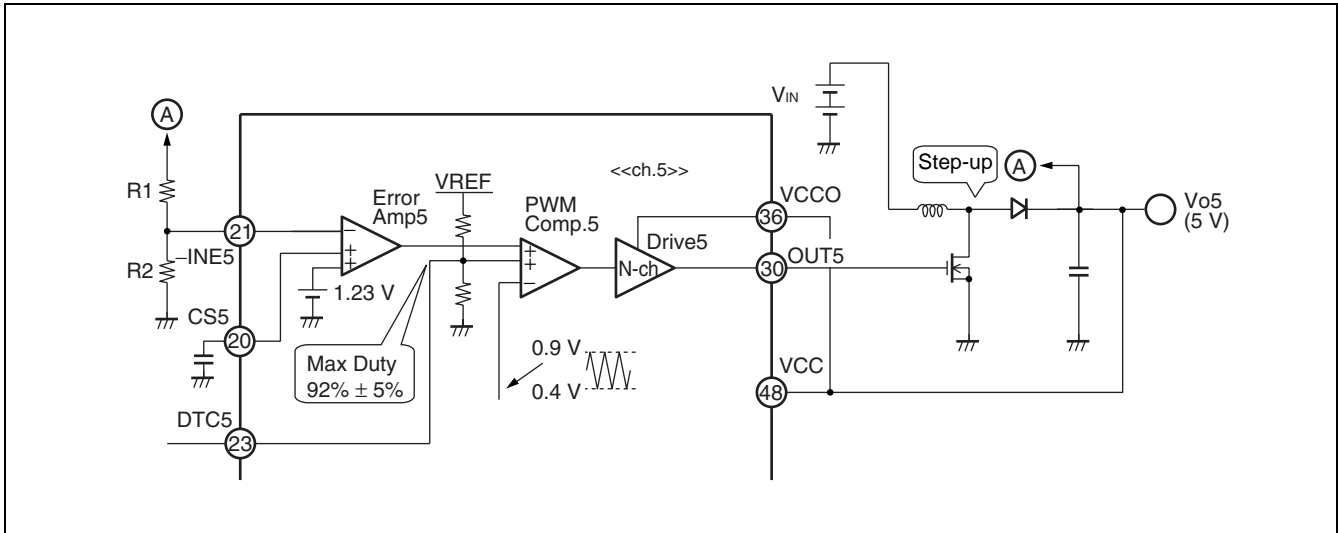

I/O EQUIVALENT CIRCUIT

Reference voltage block

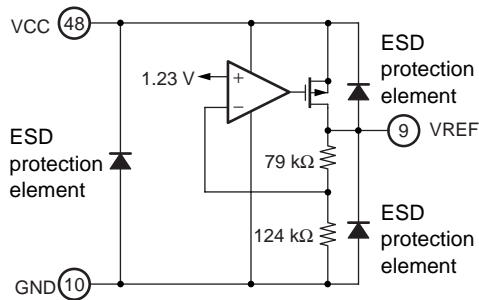

Control block (CTL, CTL1 to CTL6)

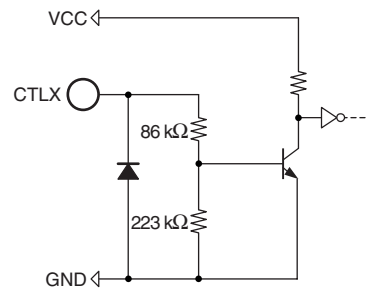

Soft-start block

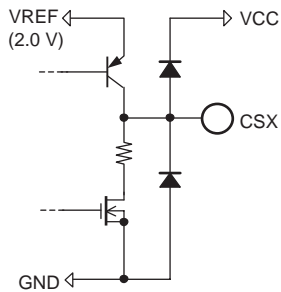

Short-circuit detection block

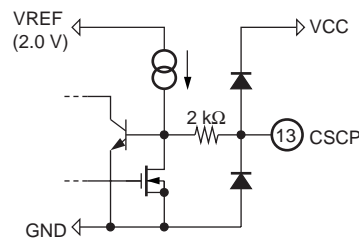

Short-circuit detection comparator block

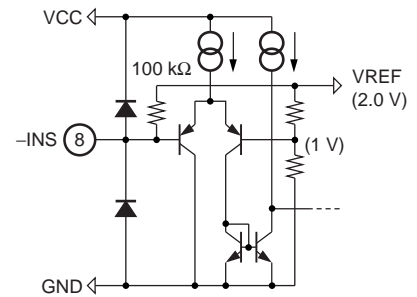

Triangular wave oscillator block (RT)

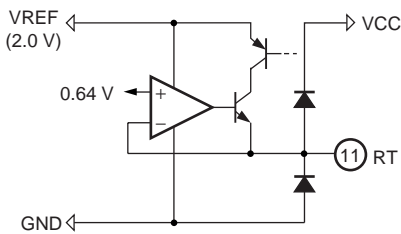

Triangular wave oscillator block (CT)

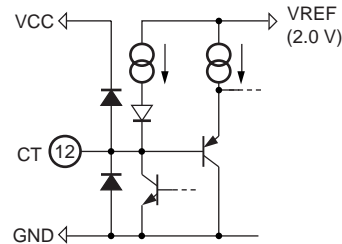

Error amplifier block (ch.1 to ch.6)

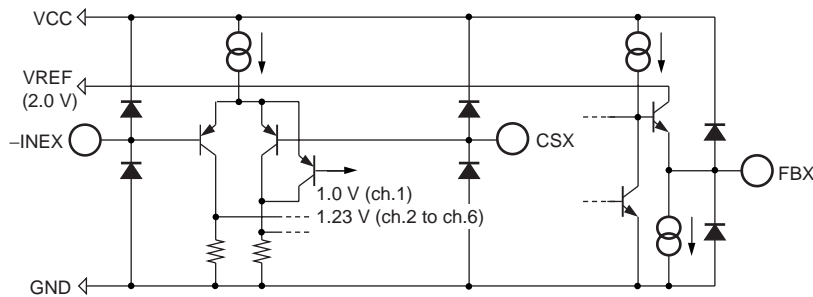

X : Each channel number

(Continued)

MB39A123

(Continued)

- Inverting amplifier block

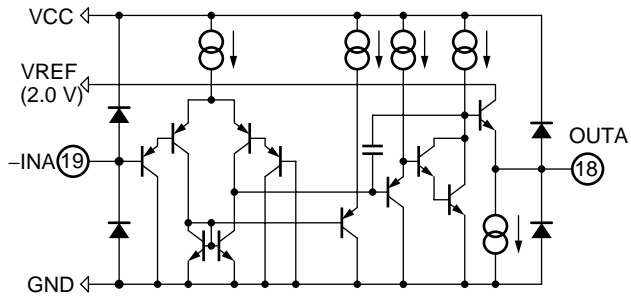

- PWM comparator block

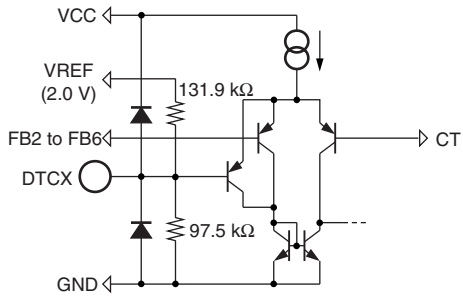

- Output block

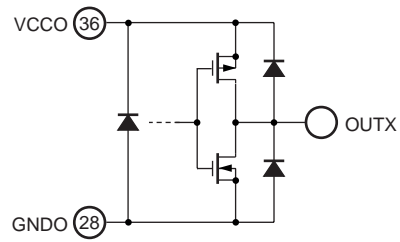

X : Each channel number

■ LAND MASK PATTERN (BCC-48++)

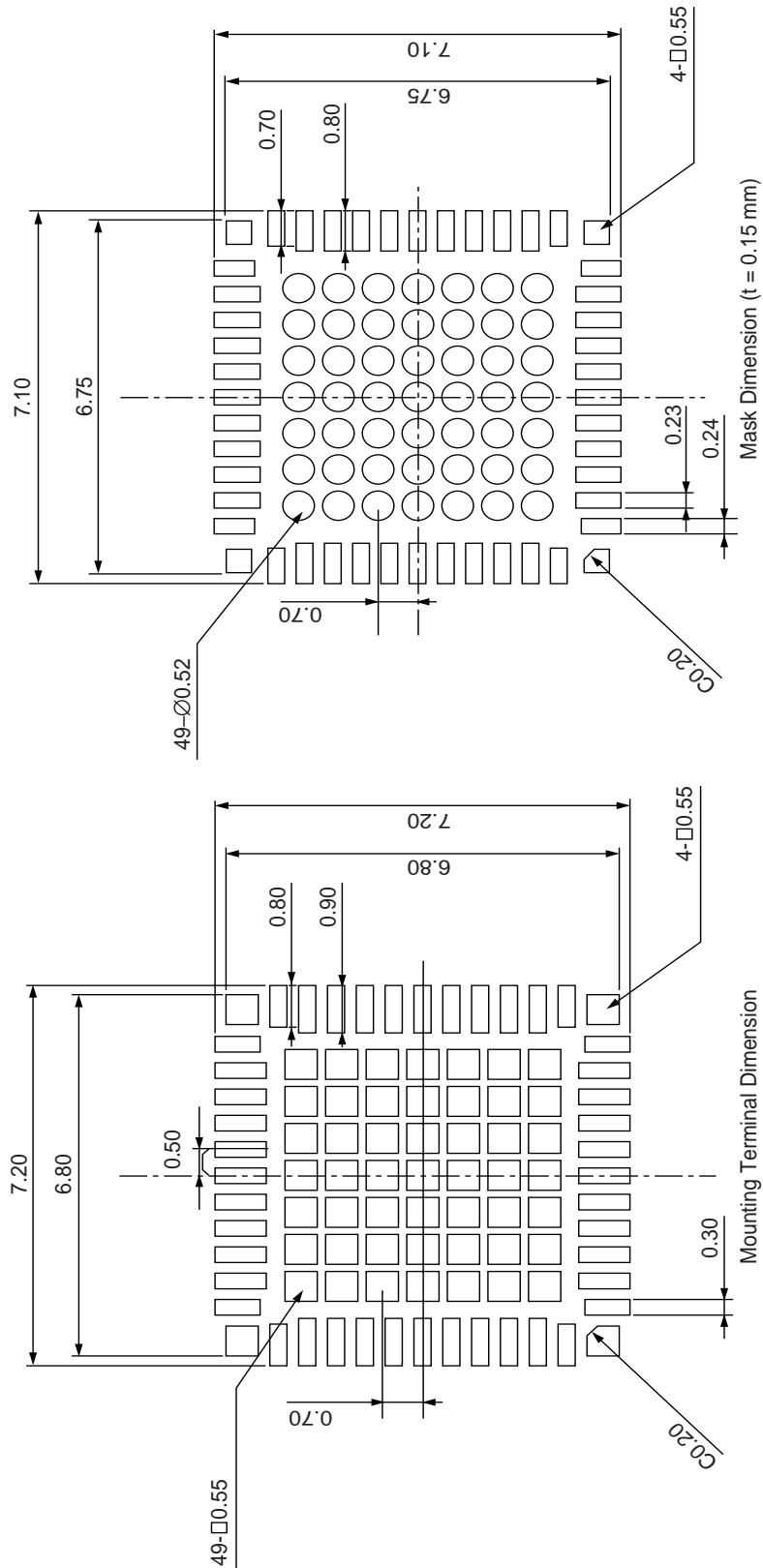

Unit : mm

MB39A123

■ USAGE PRECAUTIONS

- Printed circuit board ground lines should be set up with consideration for common impedance.
- Take appropriate static electricity measures.
 - Containers for semiconductor materials should have anti-static protection or be made of conductive material.
 - After mounting, printed circuit boards should be stored and shipped in conductive bags or containers.
 - Work platforms, tools, and instruments should be properly grounded.
 - Working personnel should be grounded with resistance of 250 kΩ to 1 MΩ between body and ground.
- Do not apply a negative voltages.
 - The use of negative voltages below -0.3 V may create parasitic transistors on LSI lines, which can cause abnormal operation.

■ ORDERING INFORMATION

Part number	Package	Remarks
MB39A123PMT-□□□E1	48-pin plastic LQFP (FPT-48P- M26)	Lead Free version
MB39A123PVK-□□□E1	48-pin plastic BCC (LCC-48P-M08)	Lead Free version

■ EV BOARD ORDERING INFORMATION

EV board part No.	EV board version No.	Remarks
MB39A123EVB-02	Board Rev.1.0	LQFP-48P

■ RoHS COMPLIANCE INFORMATION OF LEAD (Pb) FREE VERSION

The LSI products of Fujitsu with “E1” are compliant with RoHS Directive , and has observed the standard of lead, cadmium, mercury, Hexavalent chromium, polybrominated biphenyls (PBB) , and polybrominated diphenyl ethers (PBDE) .

The product that conforms to this standard is added “E1” at the end of the part number.

MARKING FORMAT (LEAD FREE VERSION)

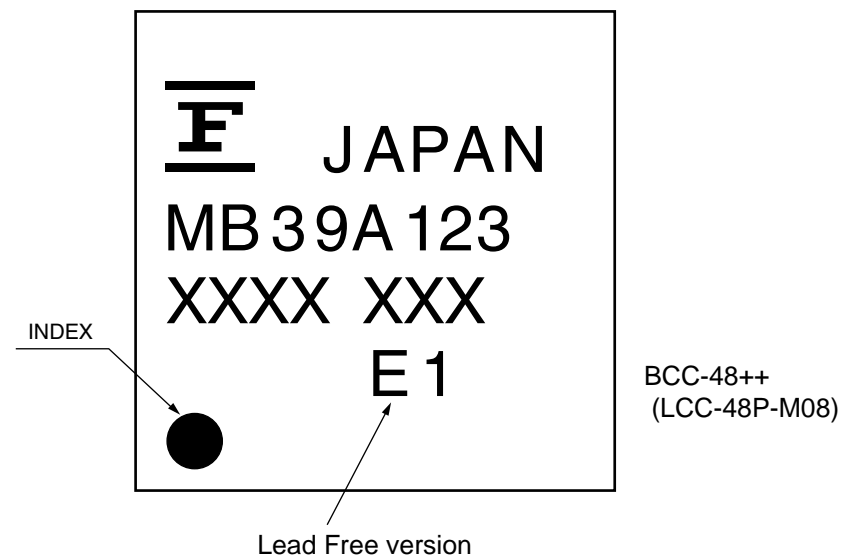
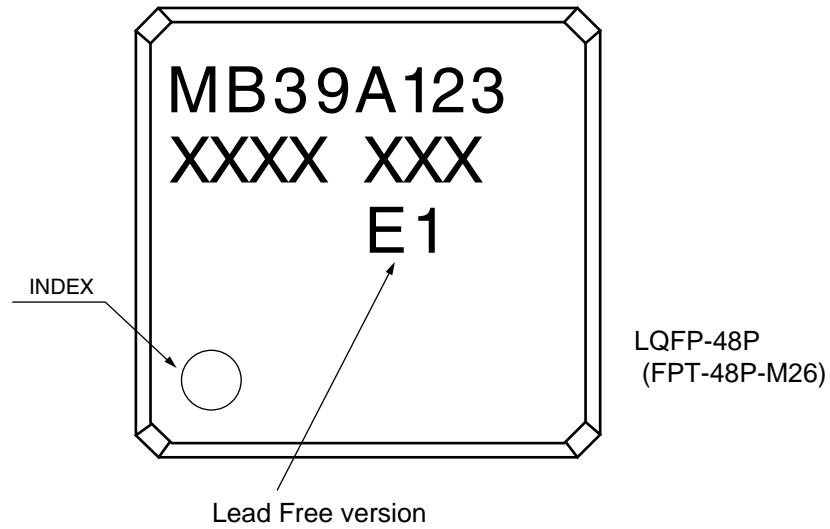

MB39A123

■ LABELING SAMPLE (LEAD FREE VERSION)

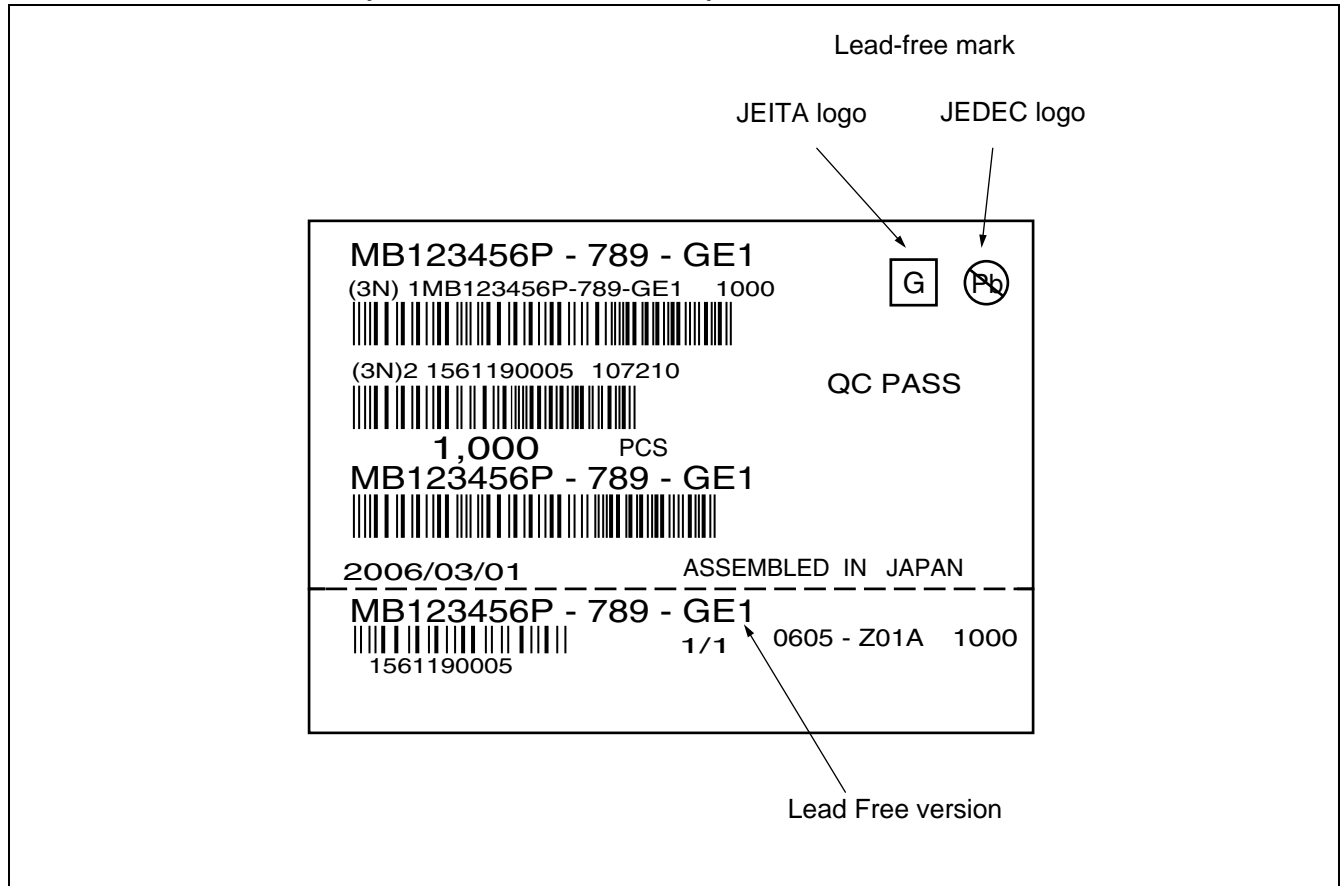

■ MB39A123PMT-□□□E1, MB39A123PVK-□□□E1 RECOMMENDED CONDITIONS OF MOISTURE SENSITIVITY LEVEL

Item	Condition	
Mounting Method	IR (infrared reflow) , Manual soldering (partial heating method)	
Mounting times	2 times	
Storage period	Before opening	Please use it within two years after Manufacture.
	From opening to the 2nd reflow	Less than 8 days
	When the storage period after opening was exceeded	Please processes within 8 days after baking (125 °C, 24H)
Storage conditions	5 °C to 30 °C, 70%RH or less (the lowest possible humidity)	

[Temperature Profile for FJ Standard IR Reflow]

(1) IR (infrared reflow)

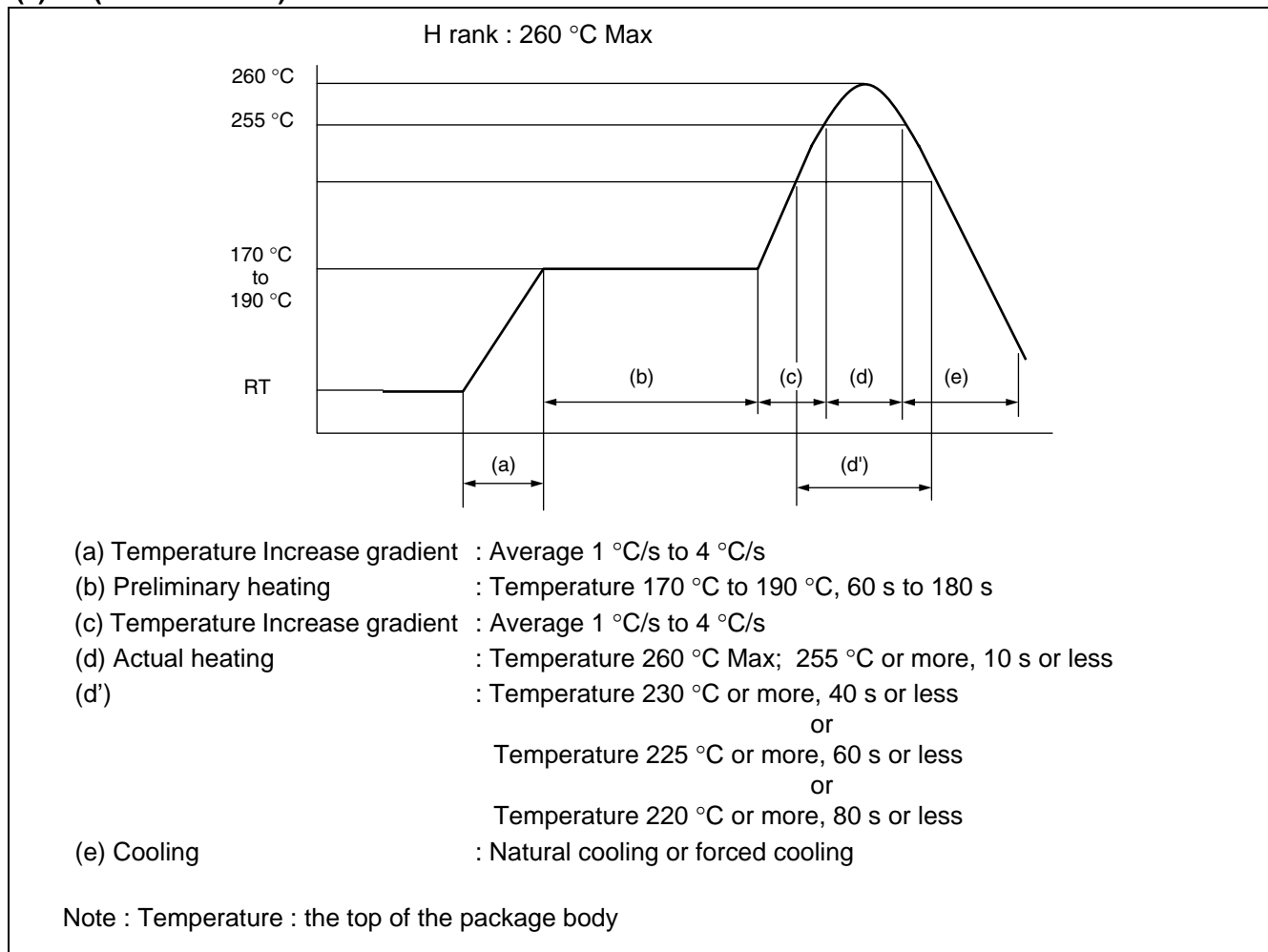

(2) Manual soldering (partial heating method)

Conditions : Temperature 400 °C Max

Times : 5 s max/pin

MB39A123

■ PACKAGE DIMENSIONS

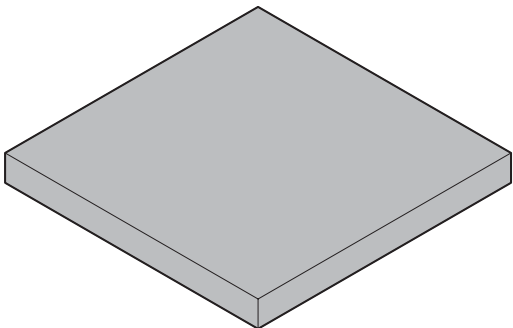
 <p>48-pin plastic BCC</p> <p>(LCC-48P-M08)</p>	Lead pitch	0.50 mm	
	Package width × package length	7.00 mm × 7.00 mm	
	Sealing method	Plastic mold	
	Mounting height	0.80 mm Max	
	Weight	0.07 g	

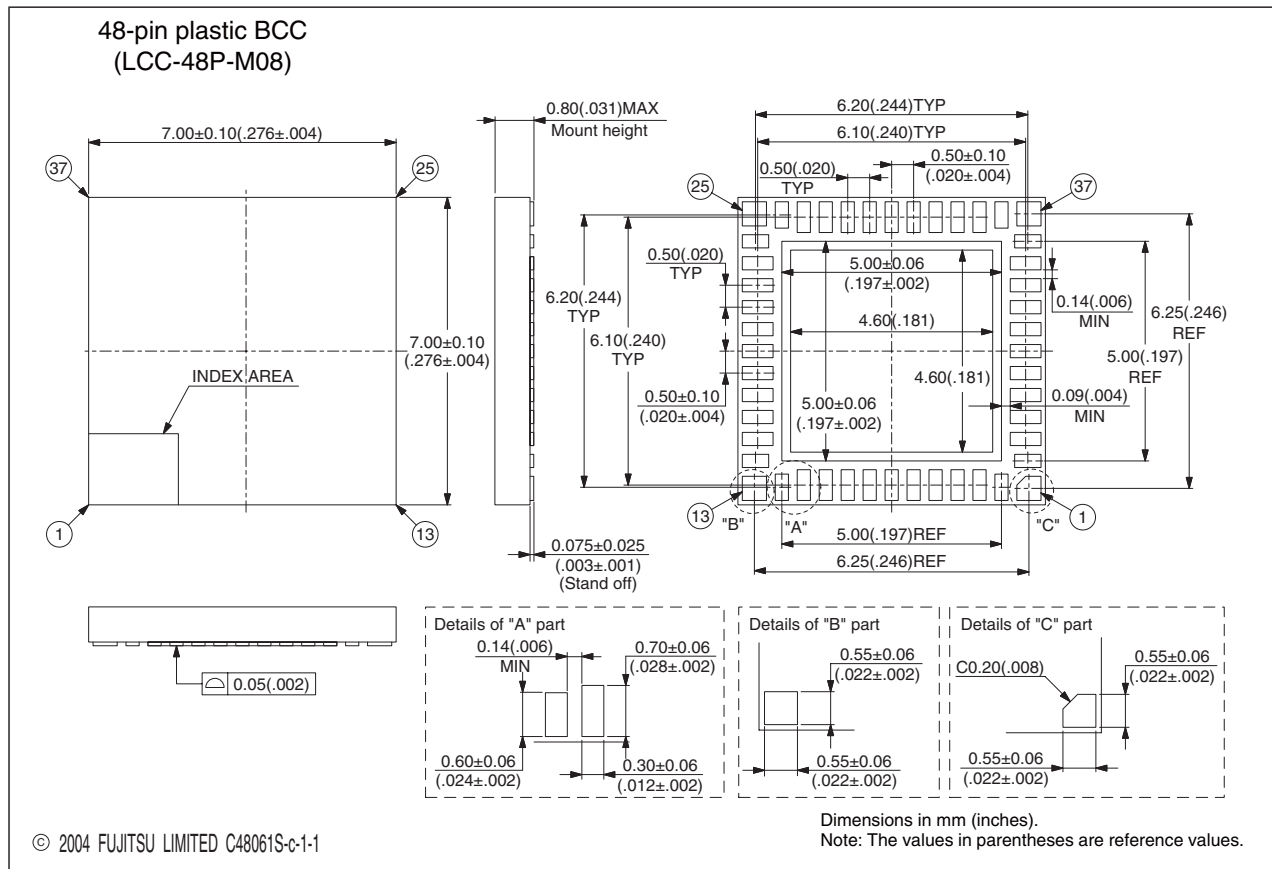

(Continued)

(Continued)

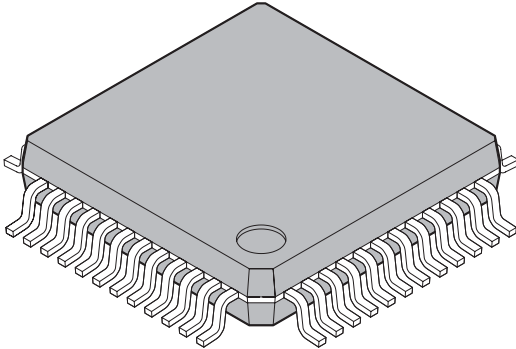
<p style="text-align: center;">48-pin plastic LQFP</p>  <p style="text-align: center;">(FPT-48P-M26)</p>	Lead pitch	0.50 mm
	Package width × package length	7 × 7 mm
	Lead shape	Gullwing
	Sealing method	Plastic mold
	Mounting height	1.70 mm MAX
	Weight	0.17 g
	Code (Reference)	P-LFQFP48-7×7-0.50

48-pin plastic LQFP
(FPT-48P-M26)

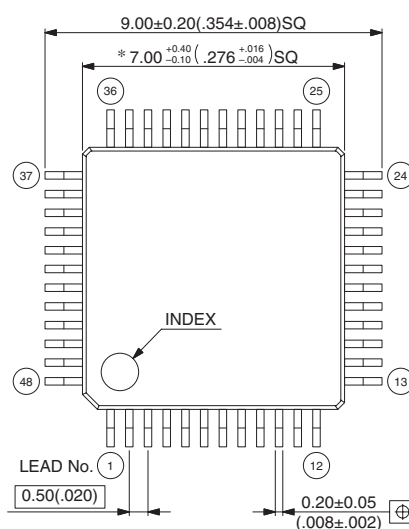

LEAD No. 1: 0.50(.020)

LEAD No. 12: 0.20±0.05 (.008±.002)

LEAD No. 13: 0.08(.003) Ⓜ

Note 1) * : These dimensions include resin protrusion.
 Note 2) Pins width and pins thickness include plating thickness.
 Note 3) Pins width do not include tie bar cutting remainder.

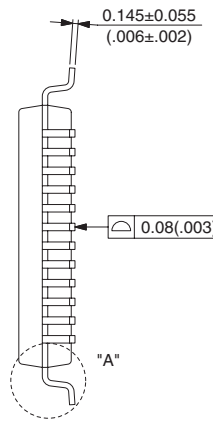

Details of "A" part

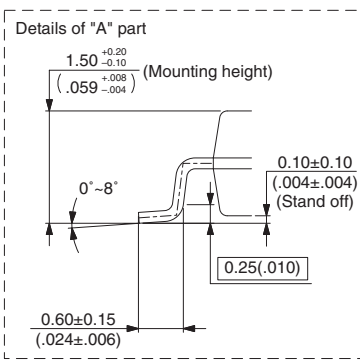

© 2003 FUJITSU LIMITED F48040S-c-2-2

Dimensions in mm (inches).
Note: The values in parentheses are reference values.

FUJITSU LIMITED

All Rights Reserved.

The contents of this document are subject to change without notice. Customers are advised to consult with FUJITSU sales representatives before ordering.

The information, such as descriptions of function and application circuit examples, in this document are presented solely for the purpose of reference to show examples of operations and uses of Fujitsu semiconductor device; Fujitsu does not warrant proper operation of the device with respect to use based on such information. When you develop equipment incorporating the device based on such information, you must assume any responsibility arising out of such use of the information. Fujitsu assumes no liability for any damages whatsoever arising out of the use of the information.

Any information in this document, including descriptions of function and schematic diagrams, shall not be construed as license of the use or exercise of any intellectual property right, such as patent right or copyright, or any other right of Fujitsu or any third party or does Fujitsu warrant non-infringement of any third-party's intellectual property right or other right by using such information. Fujitsu assumes no liability for any infringement of the intellectual property rights or other rights of third parties which would result from the use of information contained herein.

The products described in this document are designed, developed and manufactured as contemplated for general use, including without limitation, ordinary industrial use, general office use, personal use, and household use, but are not designed, developed and manufactured as contemplated (1) for use accompanying fatal risks or dangers that, unless extremely high safety is secured, could have a serious effect to the public, and could lead directly to death, personal injury, severe physical damage or other loss (i.e., nuclear reaction control in nuclear facility, aircraft flight control, air traffic control, mass transport control, medical life support system, missile launch control in weapon system), or (2) for use requiring extremely high reliability (i.e., submersible repeater and artificial satellite).

Please note that Fujitsu will not be liable against you and/or any third party for any claims or damages arising in connection with above-mentioned uses of the products.

Any semiconductor devices have an inherent chance of failure. You must protect against injury, damage or loss from such failures by incorporating safety design measures into your facility and equipment such as redundancy, fire protection, and prevention of over-current levels and other abnormal operating conditions.

If any products described in this document represent goods or technologies subject to certain restrictions on export under the Foreign Exchange and Foreign Trade Law of Japan, the prior authorization by Japanese government will be required for export of those products from Japan.

Edited Business Promotion Dept.