

1. General Description

This ROM-Based 8-bit micro-controller uses a fully static CMOS technology process to achieve high speed, small size, the low power and high noise immunity.

On chip memory includes 2K words EPROM, and 80 bytes static RAM.

2. Features

The followings are some of the features on the hardware and software :

- ◆ Fully CMOS static design
- ◆ 8-bit data bus
- ◆ On chip EPROM size : 2.0 K words
- ◆ Internal RAM size : 80 bytes
(73 general purpose registers, 7 special registers)
- ◆ 36 single word instructions
- ◆ 14-bit instructions
- ◆ 2-level stacks
- ◆ Operating voltage : 2.3 V ~ 6.0 V
- ◆ Operating frequency : 0 ~ 20 MHz
- ◆ The most fast execution time is 200 ns under 20 MHz in all single cycle instructions except the branch instruction
- ◆ Addressing modes include direct, indirect and relative addressing modes
- ◆ Power-on Reset
- ◆ Power edge-detector Reset
- ◆ Sleep Mode for power saving
- ◆ 4 types of oscillator can be selected by programming option:
RC - Low cost RC oscillator
LFXT - Low frequency crystal oscillator
XTAL - Standard crystal oscillator
HFXT - High frequency crystal oscillator
- ◆ 4 oscillator start-up time can be selected by programming option:
150 μ s, 20 ms, 40 ms, 80 ms
- ◆ 8-bit real time clock/counter(RTCC) with

8-bit programmable prescaler

- ◆ On-chip RC oscillator based Watchdog Timer(WDT)
- ◆ 12 I/O pins with their own independent direction control

3. Applications

The application areas of this MDT2030 range from appliance motor control and high speed automotive to low power remote transmitters /receivers, pointing devices, and telecommunications processors, such as Remote controller, small instruments, chargers, toy, automobile and PC peripheral ... etc.

4. Pin Assignment

		DIP / SOP			
PA2	1	18		PA1	
PA3	2	17		PA0	
RTCC	3	16		OSC1	
/MCLR	4	15		OSC2	
V _{ss}	5	14		V _{dd}	
PB0	6	13		PB7	
PB1	7	12		PB6	
PB2	8	11		PB5	
PB3	9	10		PB4	

		SSOP			
PA2	1	20		PA1	
PA3	2	19		PA0	
RTCC	3	18		OSC1	
/MCLR	4	17		OSC2	
VSS	5	16		VDD	
VSS	6	15		VDD	
PB0	7	14		PB7	
PB1	8	13		PB6	
PB2	9	12		PB5	
PB3	10	11		PB4	

This specification are subject to be changed without notice. Any latest information

5. Block Diagram

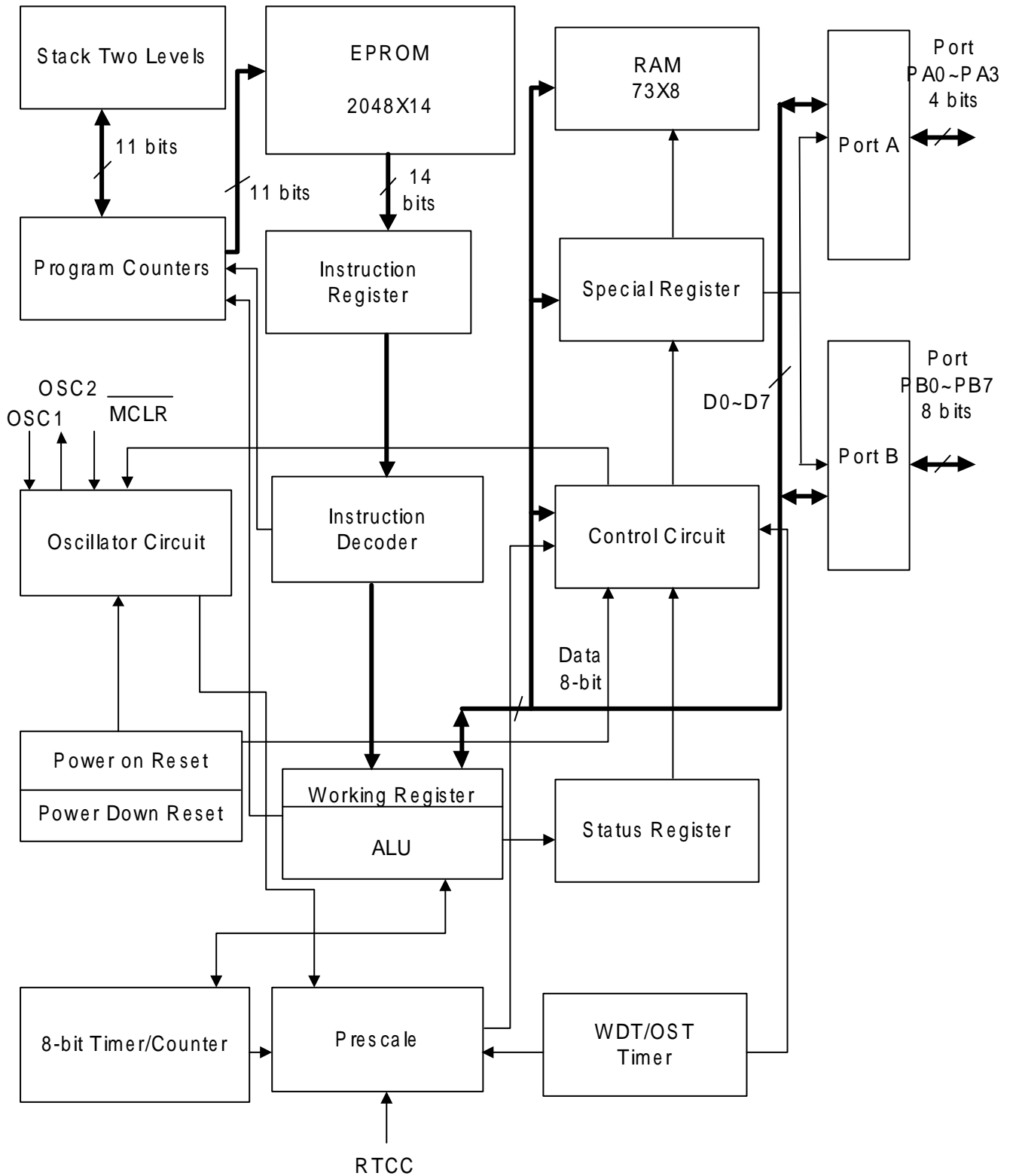

6. Pin Function Description

Pin Name	I/O	Function Description
PA0~PA3	I/O	Port A, TTL input level
PB0~PB7	I/O	Port B, TTL input level
RTCC	I	Real Time Clock/Counter, Schmitt Trigger input levels
/MCLR	I	Master Clear, Schmitt Trigger input levels
OSC1	I	Oscillator Input
OSC2	O	Oscillator Output
V _{dd}		Power supply
V _{ss}		Ground

7. Memory Map

(A) Register Map

Address	Description
00	Indirect Addressing Register
01	RTCC
02	PC
03	STATUS
04	MSR
05	Port A
06	Port B
07~1F	Internal RAM, Memory bank 0
30~3F	Internal RAM, Memory bank 1
50~5F	Internal RAM, Memory bank 2
70~7F	Internal RAM, memory bank 3

(1) IAR (Indirect Address Register) : R0

(2) RTCC (Real Time Counter/Counter Register) : R1

(3) PC (Program Counter) : R2

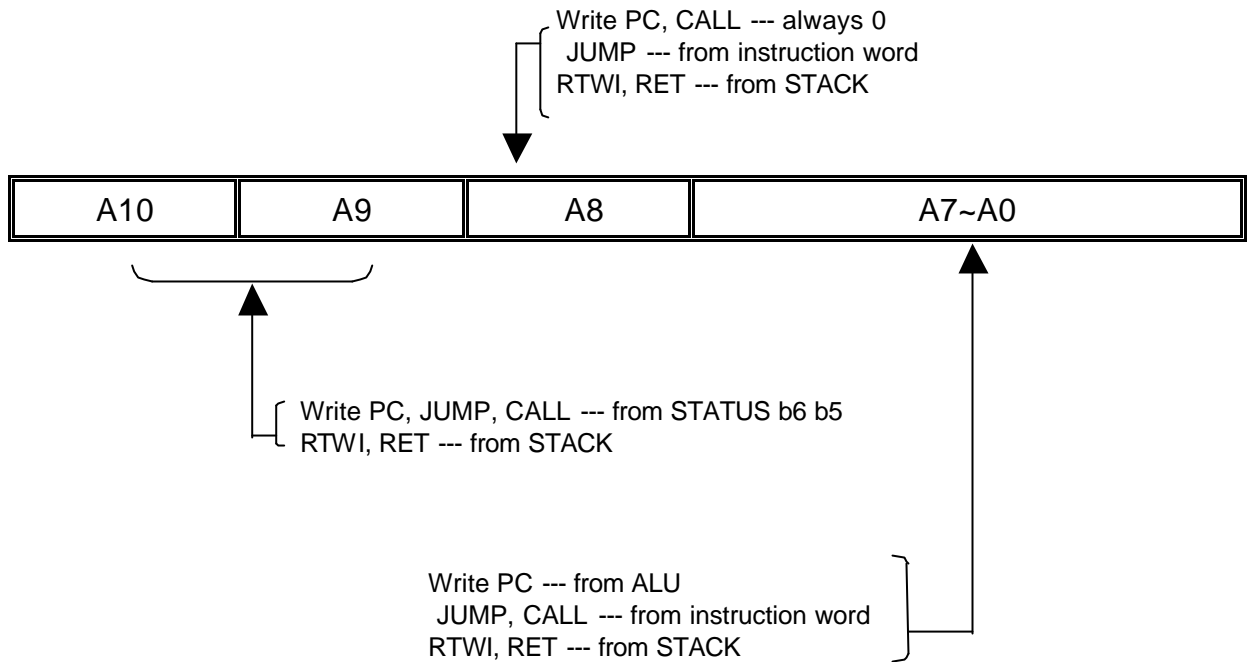

(4) STATUS (Status register) : R3

Bit	Symbol	Function
0	C	Carry bit
1	HC	Half Carry bit
2	Z	Zero bit
3	PF	Power loss Flag bit
4	TF	WDT Timer overflow Flag bit
6—5	page	ROM page select bit : 00 : Page 0, 000H --- 1FFH 01 : Page 1, 200H --- 3FFH 10 : Page 2, 400H --- 5FFH 11 : Page 3, 600H --- 7FFH
7	—	General purpose bit

(5) MSR (Memory Bank Select Register) : R4

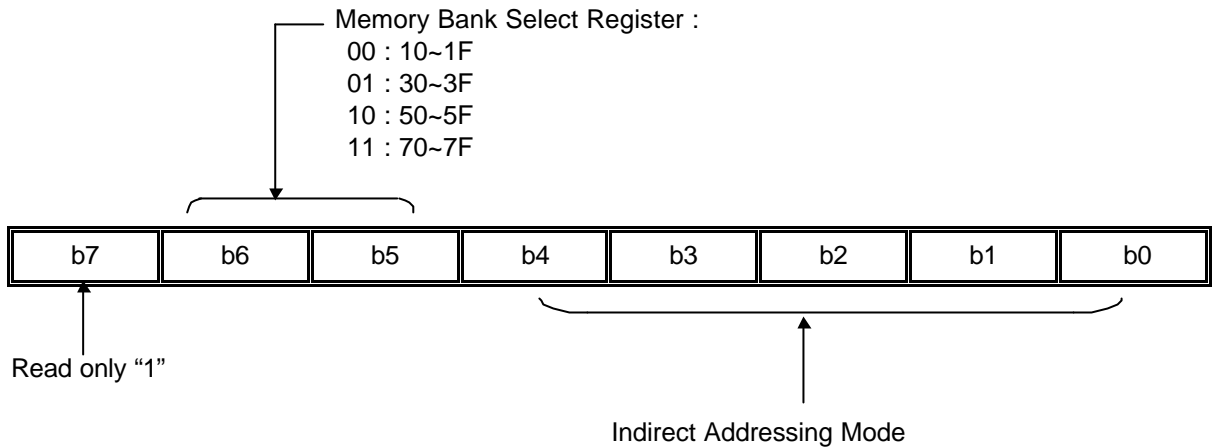

(6) PORT A : R5

PA3~PA0, I/O Register

(7) PORT B : R6

PB7~PB0, I/O Register

(8) TMR (Time Mode Register)

Bit	Symbol	Function		
		Prescaler Value	RTCC rate	WDT rate
2—0	PS2—0	0 0 0	1 : 2	1 : 1
		0 0 1	1 : 4	1 : 2
		0 1 0	1 : 8	1 : 4
		0 1 1	1 : 16	1 : 8
		1 0 0	1 : 32	1 : 16
		1 0 1	1 : 64	1 : 32
		1 1 0	1 : 128	1 : 64
		1 1 1	1 : 256	1 : 128
3	PSC	Prescaler assignment bit : 0 — RTCC 1 — Watchdog Timer		
4	TCE	RTCC signal Edge : 0 — Increment on low-to-high transition on RTCC pin 1 — Increment on high-to-low transition on RTCC pin		
5	TCS	RTCC signal set : 0 — Internal instruction cycle clock 1 — Transition on RTCC pin		

(9) CPIO A, CPIO B (Control Port I/O Mode Register)

The CPIO register is "write-only"

= "0", I/O pin in output mode;

= "1", I/O pin in input mode.

(10) Configurable options for EPROM (Set by writer) :

Oscillator Type	Oscillator Start-up Time
RC Oscillator	150 μ s,20ms,40ms,80ms
HFXT Oscillator	20 ms,40ms,80ms
XTAL Oscillator	20ms,40 ms,80ms
LFXT Oscillator	40 ms,80 ms

Watchdog Timer control
Watchdog timer disable all the time
Watchdog timer enable all the time

Power Edge Detect
PED Disable
PED Enable

Security state
Security weak Disable
Security Disable
Security Enable

The default security state of EPROM is weak disable. Once the IC was set to enable or disable, it's forbidden to change.

(B) Program Memory

Address	Description
000-7FF	Program memory
7FF	The starting address of power on, external reset or WDT time-out reset.

8. Reset Condition for all Registers

Register	Address	Power-On Reset	/MCLR or WDT Reset
CPIO A	- -	1111 1111	1111 1111
CPIO B	- -	1111 1111	1111 1111
TMR	- -	--11 1111	--11 1111
IAR	00h	-	-
RTCC	01h	xxxx xxxx	uuuu uuuu
PC	02h	1111 1111	1111 1111
STATUS	03h	0001 1xxx	000# #uuu
MSR	04h	100x xxxx	100u uuuu

Register	Address	Power-On Reset	/MCLR or WDT Reset
PORT A	05h	---- xxxx	---- uuuu
PORT B	06h	xxxx xxxx	uuuu uuuu

Note : u = unchanged, x = unknown, - = unimplemented, read as "0"

= value depends on the condition of the following table

Condition	Status: bit 4	Status: bit 3
/MCLR reset (not during SLEEP)	u	u
/MCLR reset during SLEEP	1	0
WDT reset (not during SLEEP)	0	1
WDT reset during SLEEP	0	0

9. Instruction Set :

Instruction Code	Mnemonic Operands	Function	Operating	Status
010000 00000000	NOP	No operation	None	
010000 00000001	CLRWT	Clear Watchdog timer	0 WT	TF, PF
010000 00000010	SLEEP	Sleep mode	0 WT, stop OSC	TF, PF
010000 00000011	TMODE	Load W to TMODE register	W TMODE	None
010000 00000100	RET	Return	Stack PC	None
010000 00000rrr	CPIO R	Control I/O port register	W CPIO r	None
010001 1rrrrrrr	STWR R	Store W to register	W R	None
011000 trrrrrrr	LDR R, t	Load register	R t	Z
111010 iiiiii	LDWI I	Load immediate to W	I W	None
010111 trrrrrrr	SWAPR R, t	Swap halves register	[R(0-3) ↔ R(4-7)] t	None
011001 trrrrrrr	INCR R, t	Increment register	R + 1 t	Z
011010 trrrrrrr	INCRSZ R, t	Increment register, skip if zero	R + 1 t	None
011011 trrrrrrr	ADDWR R, t	Add W and register	W + R t	C, HC, Z
011100 trrrrrrr	SUBWR R, t	Subtract W from register	R - W t or (R+/W+1 t)	C, HC, Z
011101 trrrrrrr	DECR R, t	Decrement register	R - 1 t	Z
011110 trrrrrrr	DECRSZ R, t	Decrement register, skip if zero	R - 1 t	None
010010 trrrrrrr	ANDWR R, t	AND W and register	R W t	Z
110100 iiiiii	ANDWI i	AND W and immediate	i W W	Z
010011 trrrrrrr	IORWR R, t	Inclu. OR W and register	R W t	Z
110101 iiiiii	IORWI i	Inclu. OR W and immediate	i W W	Z

This specification are subject to be changed without notice. Any latest information

Instruction Code	Mnemonic Operands	Function	Operating	Status
010100 trrrrrr	XORWR R, t	Exclu. OR W and register	R W t	Z
110110 iiiiii	XORWI i	Exclu. OR W and immediate	i W W	Z
011111 trrrrrr	COMR R, t	Complement register	/R t	Z
010110 trrrrrr	RRR R, t	Rotate right register	R(n) R(n-1), C R(7), R(0) C	C
010101 trrrrrr	RLR R, t	Rotate left register	R(n) r(n+1), C R(0), R(7) C	C
010000 1xxxxxxx	CLRW	Clear working register	0 W	Z
010001 0rrrrrr	CLRR R	Clear register	0 R	Z
0000bb brrrrrr	BCR R, b	Bit clear	0 R(b)	None
0010bb brrrrrr	BSR R, b	Bit set	1 R(b)	None
0001bb brrrrrr	BTSC R, b	Bit Test, skip if clear	Skip if R(b)=0	None
0011bb brrrrrr	BTSS R, b	Bit Test, skip if set	Skip if R(b)=1	None
1000nn nnnnnnnn	LCALL n	Long CALL subroutine	n PC, PC+1 Stack	None
1010nn nnnnnnnn	LJUMP n	Long JUMP to address	n PC	None
110000 nnnnnnnn	CALL n	Call subroutine	n PC, PC+1 Stack	None
110001 iiiiii	RTWI i	Return, place immediate to W	Stack PC,i W	None
11001n nnnnnnnn	JUMP n	JUMP to address	n PC	None

Note :

- | | | | |
|--------|-----------------------------|----|-----------------------------|
| W | : Working register | b | : Bit position |
| WT | : Watchdog timer | t | : Target |
| TMODE | : TMODE mode register | 0 | : Working register |
| CPIO | : Control I/O port register | 1 | : General register |
| TF | : Timer overflow flag | R | : General register address |
| PF | : Power loss flag | C | : Carry flag |
| PC | : Program Counter | HC | : Half carry |
| OSC | : Oscillator | Z | : Zero flag |
| Inclu. | : Inclusive ' ' | / | : Complement |
| Exclu. | : Exclusive ' ' | x | : Don't care |
| AND | : Logic AND ' ' | i | : Immediate data (8 bits) |
| | | n | : Immediate address |

10. Electrical Characteristics

(Operating temperature at 25 °C).

Sym	Description	Condition	Min	Typ	Max	Unit
V _{DD}	Operating voltage		2.3		6.0	V
V _{IL}	Input Low Voltage PA, PB	V _{DD} =5V	-0.6		1.0	V
		RTCC, /MCLR	V _{DD} =5V	-0.6	1.0	V
V _{IH}	Input high Voltage PA, PB	V _{DD} =5V	2.0		V _{DD}	V
		RTCC, /MCLR	V _{DD} =5V	3.3	V _{DD}	V
I _{IL}	Input leakage current	V _{DD} =5V			+/-1	μA
V _{OL}	Output Low Voltage PA, PB	V _{DD} =5V, I _{OL} =20mA		0.5		V
		V _{DD} =5V, I _{OL} =5mA		0.1		V
V _{OH}	Output High Voltage PA, PB	V _{DD} =5V, I _{OH} = -20mA		3.8		V
		V _{DD} =5V, I _{OH} = -5mA		4.5		V
I _{slp}	Sleep current (WDT disable)	V _{DD} = 2.3 ~ 6.0 V		0.1	1.0	μA
I _{slp}	Sleep current (WDT enable)	V _{DD} = 2.3 V		1		μA
		V _{DD} = 3.0 V		3		μA
		V _{DD} = 4.0 V		6		μA
		V _{DD} = 5.0 V		11		μA
		V _{DD} = 6.0 V		17		μA
V _{pr}	Power Edge-detector Reset Voltage		1.1		1.3	V
T _{wdt}	The basic WDT time-out cycle time	V _{DD} = 2.3 V		25.2		mS
		V _{DD} = 3.0 V		22.4		mS
		V _{DD} = 4.0 V		20.4		mS
		V _{DD} = 5.0 V		18.8		mS
		V _{DD} = 6.0 V		18.0		mS
T _{FLT}	/MCLR filter	V _{DD} = 5.0 V		600		nS
I _{CC}	Comparator Supply current (one comparator)	V _{DD} =5.0v		15		μA
V _{ref}	Input reference voltage	V _{DD} =2.5v ~6.0 V			V _{DD} -0.8 v	V

This specification are subject to be changed without notice. Any latest information

Sym	Description	Condition	Min	Typ	Max	Unit
---	Comparator Response time	Vdd=5.0v , V- = Vref V+ = (PA0~PA3)				
	V-=Vdd/4, V+=V- ± 0.2v			8		μS
	V-=Vdd/2, V+=V- ± 0.2v			8		μS
	V-=Vdd3/4, V+=V- ± 0.2v			8		μS
	V-=VDD-0.8, V+=V± 0.2v			8		μS

11. Operating Current

Temperature = 25 , the typical value as followings :

11.1 OSC Type = RC (OSC1&OSC2 Internal Cap about 10P); WDT - Enable;
 Comparator - Disable ; PED=Disable V_{dd} = 5.0 V

Cext. (F)	Rext. (Ohm)	Frequency (Hz)	Current (A)
0P	4.7 K	7.76M	980 μA
	10.0 K	3.82M	560 μA
	47.0 K	848K	240 μA
	100.0 K	404K	185 μA
	300.0 K	135.6K	155 μA
	470.0 K	86K	150 μA
3P	4.7 K	6.8M	880 μA
	10.0 K	3.34M	510 μA
	47.0 K	740K	230 μA
	100.0 K	356K	185 μA
	300.0 K	119K	155 μA
	470.0 K	75.2K	150 μA
20P	4.7 K	4.16M	610 μA
	10.0 K	2.04M	380 μA
	47.0 K	452K	200 μA
	100.0 K	214.8K	175 μA
	300.0 K	75.2K	155 μA
	470.0 K	45.6K	151 μA

Cext. (F)	Rext. (Ohm)	Frequency (Hz)	Current (A)
100P	4.7 K	1.57M	335 μ A
	10.0 K	764K	245 μ A
	47.0 K	167.2K	175 μ A
	100.0 K	76.8K	165 μ A
	300.0 K	26.6K	160 μ A
	470.0 K	16.8K	155 μ A
300P	4.7 K	672K	235 μ A
	10.0 K	321.6K	195 μ A
	47.0 K	70.4K	165 μ A
	100.0 K	33.2K	160 μ A
	300.0 K	11.1K	158 μ A
	470.0 K	7.04K	156 μ A

11.2 OSC Type = LF (OSC1&OSC2 Internal Cap about 10P); WDT - Enable ;
 Comparator - Disable ; PED=Disable

Voltage/Frequency	32 K	455 K	1 M	Sleep
2.3 V	7.0 μ A	25 μ A	40 μ A	< 1.0 μ A
3.0 V	15.0 μ A	45 μ A	65 μ A	3 μ A
4.0 V	35.0 μ A	85 μ A	115 μ A	6 μ A
5.0 V	70.0 μ A	140 μ A	180 μ A	11 μ A
6.0 V	130 μ A	215 μ A	260 μ A	17 μ A

11.3 OSC Type = XT (OSC1&OSC2 Internal Cap about 10P); WDT - Enable ;
 Comparator - Disable ; PED=Enable

Voltage/Frequency	1 M	4 M	10 M	Sleep
2.1 V	50 μ A	120 μ A	290 μ A	< 1.0 μ A
3.0 V	100 μ A	230 μ A	490 μ A	3 μ A
4.0 V	210 μ A	400 μ A	650 μ A	6 μ A
5.0 V	375 μ A	590 μ A	1.3mA	11 μ A
6.0 V	645 μ A	850 μ A	1.6mA	17 μ A

11.4 OSC Type = HF (OSC1&OSC2 Internal Cap about 10P); WDT - Enable ;
 Comparator - Disable ; PED=Enable

Voltage/Frequency	4 M	10 M	20 M	Sleep
2.1 V	150 μ A	320 μ A	X	< 1.0 μ A
3.0 V	280 μ A	550 μ A	925 μ A	3 μ A
4.0 V	510 μ A	910 μ A	1.5mA	6 μ A
5.0 V	800 μ A	1.4mA	2.3mA	11 μ A
6.0 V	1.3mA	1.9mA	3.2mA	17 μ A

11.5 Power Edge-detector Reset Voltage (Not in Sleep Mode), @ $V_{dd} = 5.0$ V

V_{pr} 1.8~2.2 V

V_{pr} : V_{dd} (Power Supply)

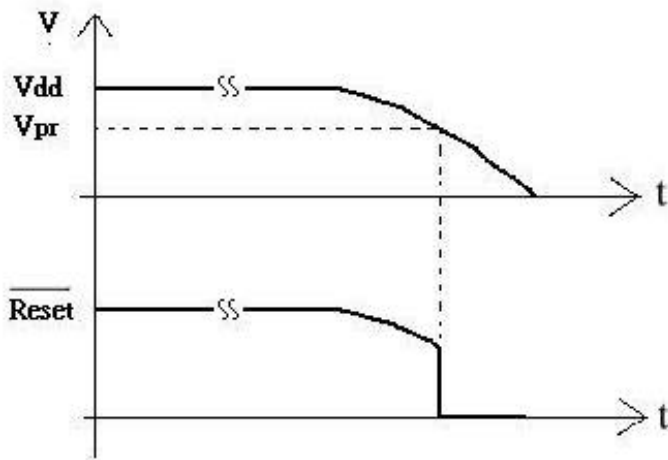

12. Port A and Port B Equivalent Circuit

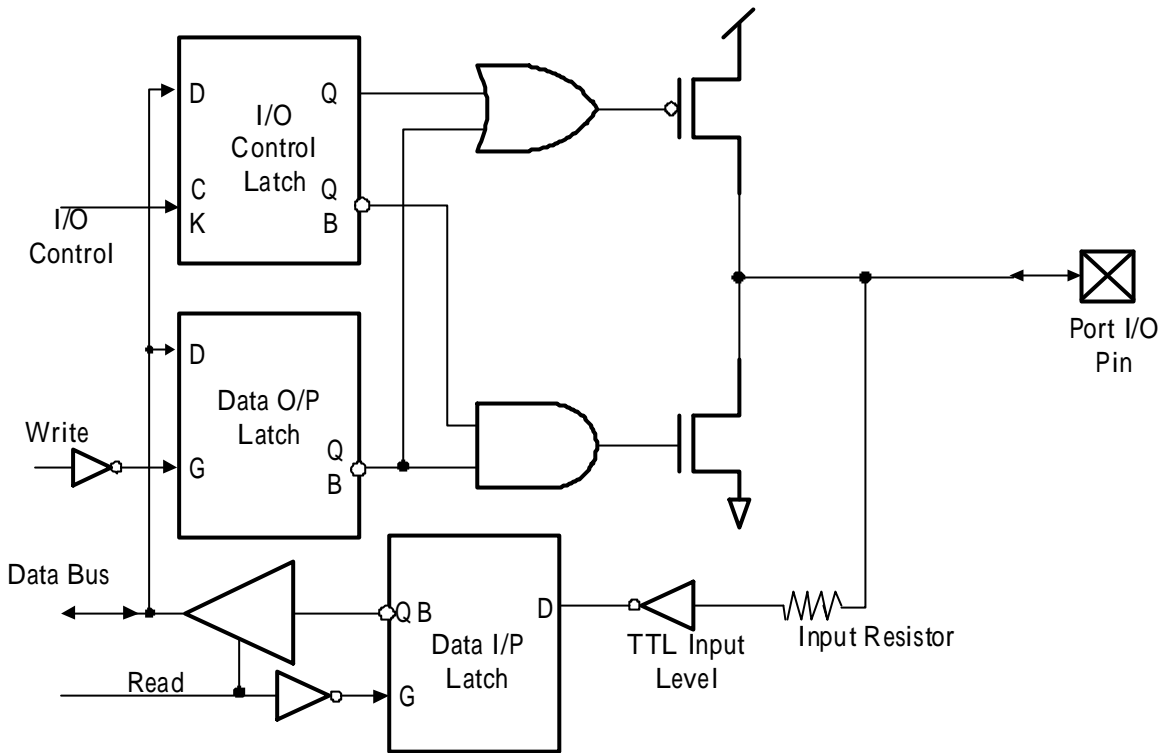

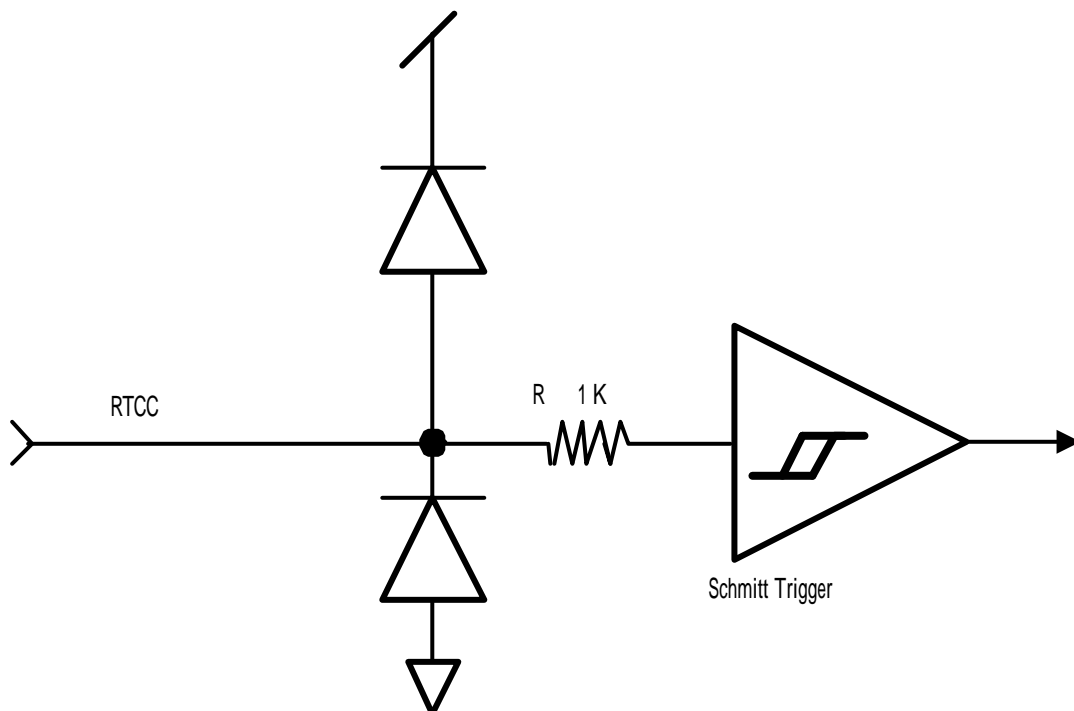
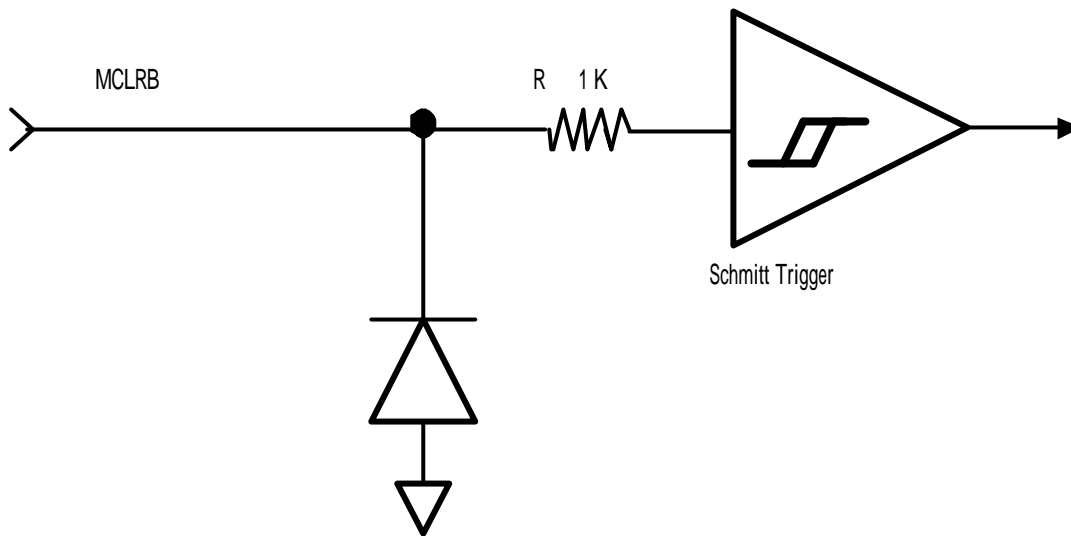
13. MCLR_B and RTCC Input Equivalent Circuit

14. External Capacitor Selection For Crystal Oscillator

@ $V_{dd} = 5.0\text{ V}$

Osc. Type	Resonator Freq.	Capacity Range
HF	20 MHz	10 pF ~ 50 pF
	10 MHz	20 pF ~ 50 pF
	4 MHz	10 pF ~ 30 pF
XT	10 MHz	10 pF ~ 50 pF
	4 MHz	10 pF ~ 50 pF
	1 MHz	20 pF ~50 pF
LF	1 MHz	20 pF ~ 30 pF
	455 K	20 pF ~30 pF
	32 K	20 pF ~30 pF

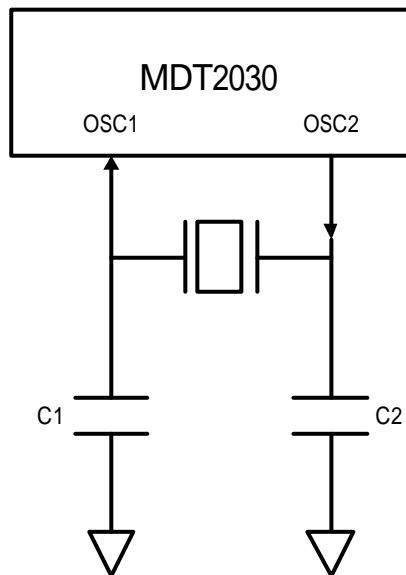

To increase the stability of oscillator and the ability of anti-noise, the above values of the external capacitor are for reference only, but the higher capacitance also increases the start-up time.