

# R 4A

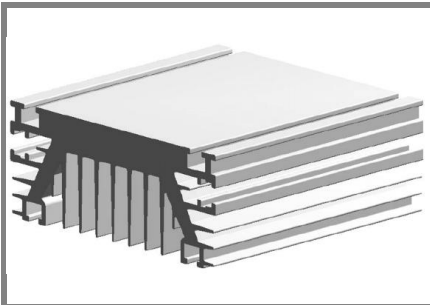

## Heatsink

For isolated power modules

R 4A

Publish Data

### Features

- Intended for isolated power modules: the SEMIPACK and SEMITRANS ranges, also for the SEMIPONT bridge rectifier range
- Designed mainly for forced air cooling
- Available in various lengths

Standard lengths	n	b / d Ø mm	$R_{thha}$ (P = 30W) natural cooling K/W	$R_{thha}$ $V_{air} = 4$ m/s K/W	w kg
R 4A/120	1		1,4	0,38	0,6
	2		1,33		

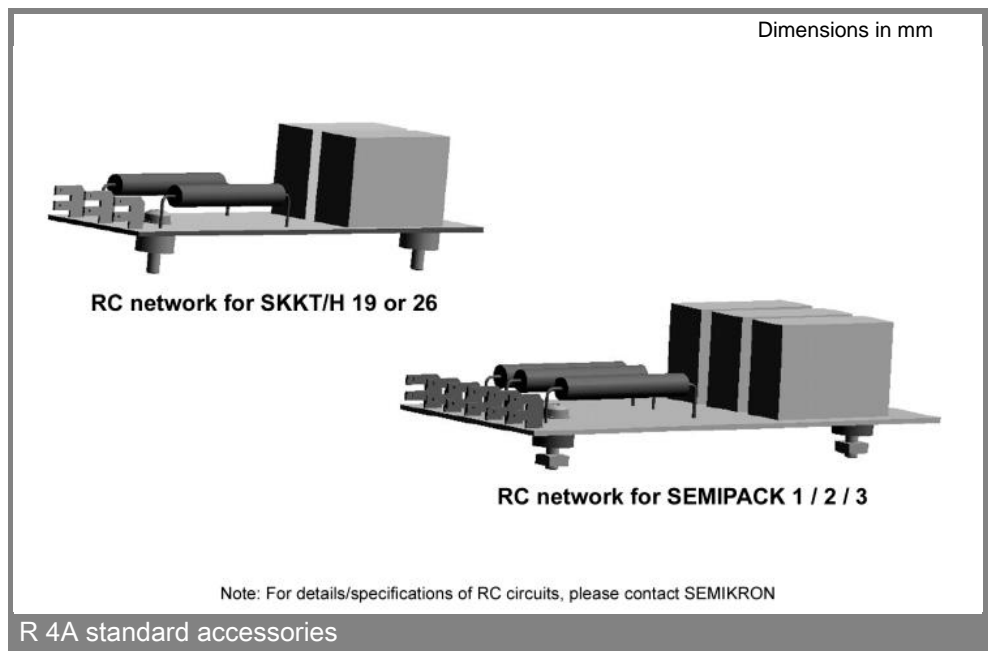
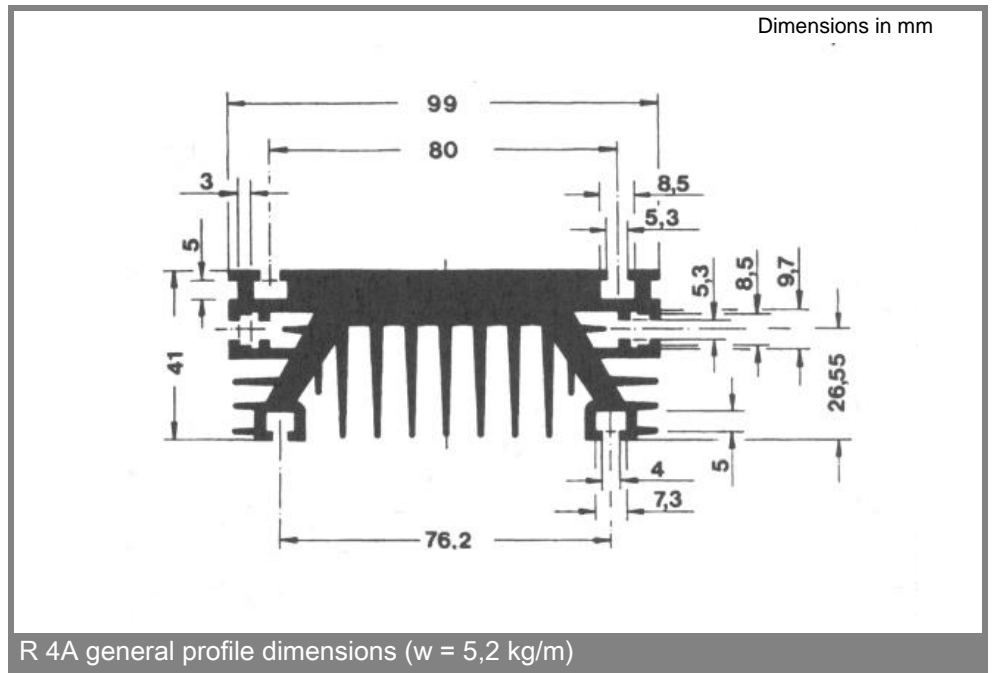

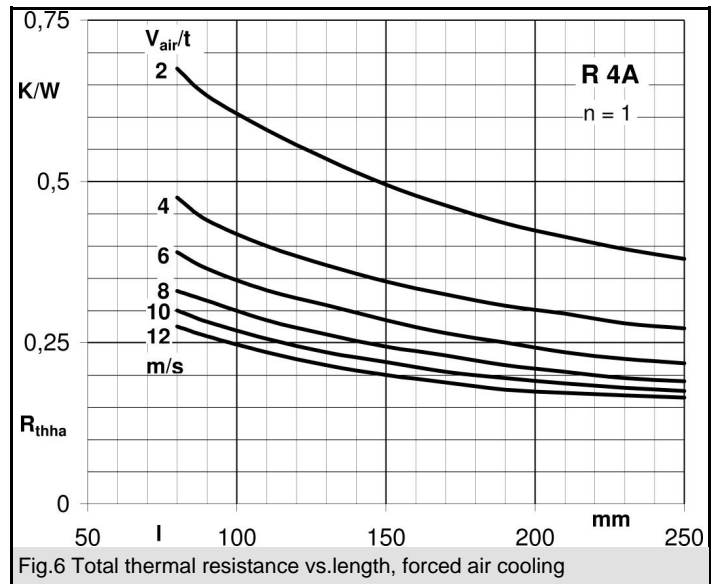
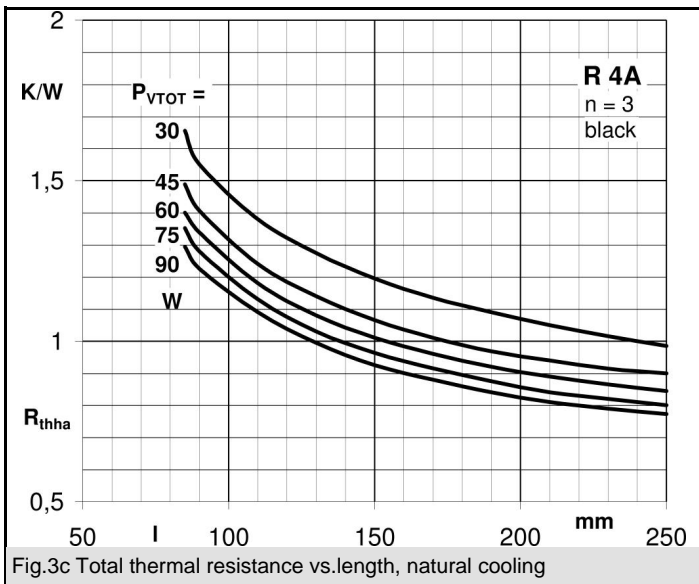
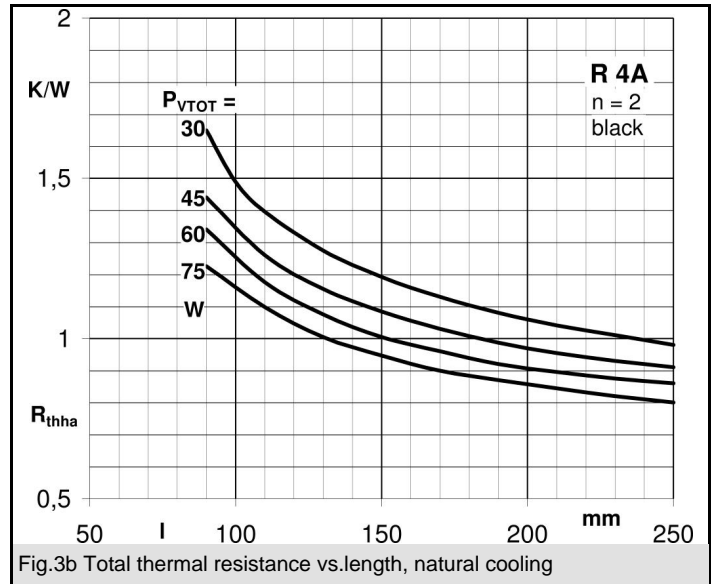
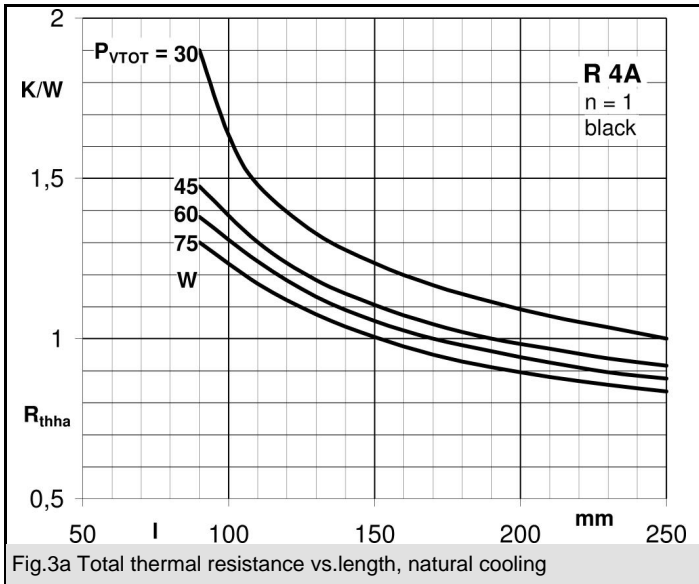

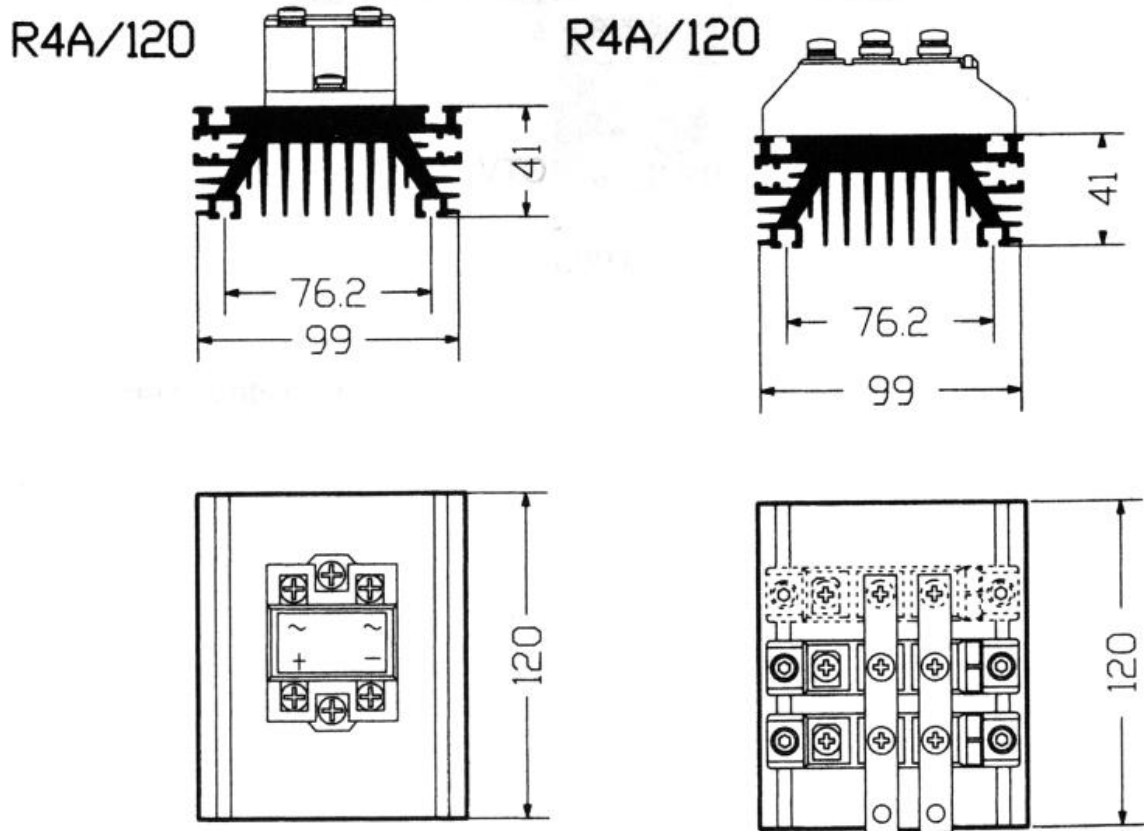

1. Application examples using heatsink R 4A/120 with SEMIPONT or SEMIPACK modules to give single or three phase bridges rectifiers