

# SP4653

## 1GHz ÷ 256 PRESCALER WITH LOW CURRENT AND LOW RADIATION

The SP4653 ÷ 256 prescaler is one of GPS' range of high speed dividers for consumer frequency synthesis and measurement systems. It has a lower supply current giving reduced dissipation and operating temperatures in 8-pin plastic DIL package. Spurious radiation has been reduced from all stages.

The SP4653 incorporates an on-chip preamplifier with differential inputs and has a balanced ECL outputs.

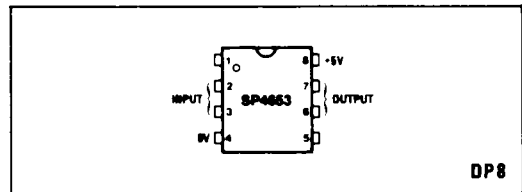

Fig. 1 Pin connections - top view

### FEATURES

- Low Supply Current
- Low Radiation
- Input Wideband Amplifier
- High Input Sensitivity
- High Input Impedance
- Balanced ECL Outputs

### ABSOLUTE MAXIMUM RATINGS

Supply voltage	V <sub>CC</sub> +7V
Input voltage	2.5V p-p
Storage temperature	-55°C to +125°C
Operating temperature range	0°C to +80°C

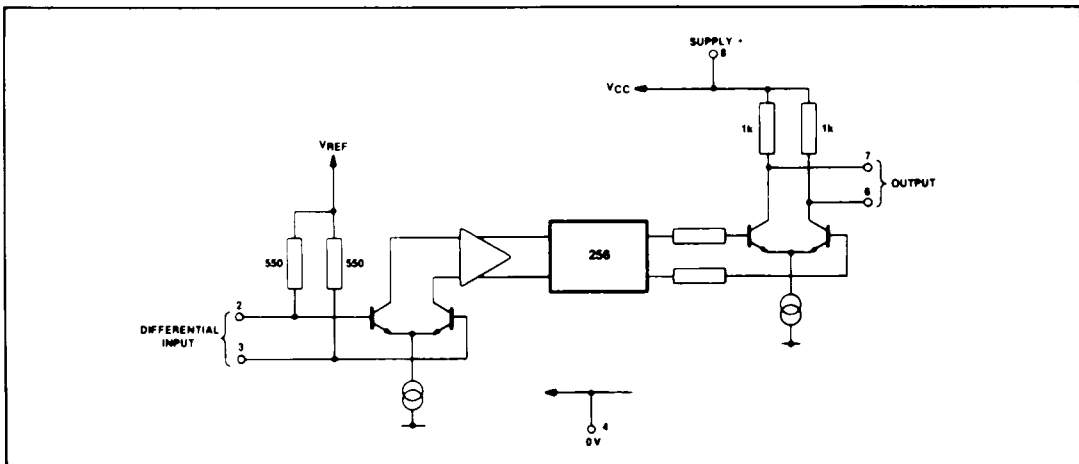

Fig 2 SP4653 block diagram

**ELECTRICAL CHARACTERISTICS**

**Test conditions (unless otherwise stated):**

T<sub>amb</sub> = 0°C to +70°C, V<sub>cc</sub> = 4.5V to 5.5V (Test circuit see Fig.3)

Characteristic	Pin	Value			Units	Conditions
		Min.	Typ.	Max.		
Supply current	8		25	35	mA	V <sub>cc</sub> = 5V
Input sensitivity	2,3			17.5		RMS sinewave
70MHz			8	14	mV	
150MHz			4	10	mV	
300MHz			3	10	mV	
500MHz			3	10	mV	
700MHz			3	10	mV	
900MHz			4	10	mV	
1050MHz			6	14	mV	
Input overload	2,3	200			mV	70MHz to 1050MHz operating frequency
Input impedance	2,3		50		ohms	See Fig.6
			2		pF	
Output voltage no load	6	0.8			V p-p	} fin = 1GHz Vcc = 5V
	7	0.8			V p-p	
Output voltage load as Fig.3	6	0.6			V p-p	} fin = 1GHz Vcc = 5V
	7	0.6			V p-p	
Output impedance	6		1		kohms	
	7		1		kohms	
Output imbalance	6,7		0.1		V	

**NOTE**

The difference between the maximum input sensitivity and minimum overload voltages is the guaranteed dynamic range. Input signal levels should be maintained within these limits at all frequencies.

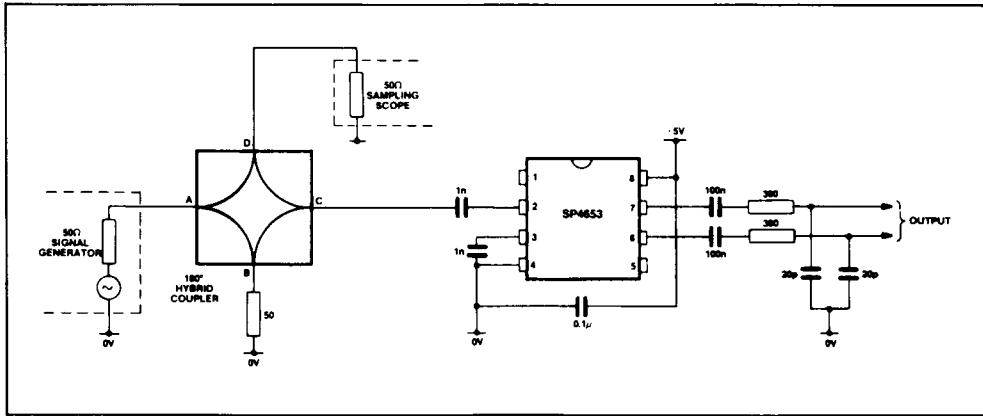

Fig.3 Test circuit

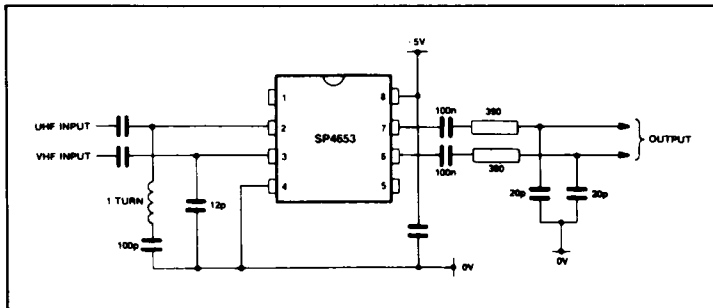

Fig.4 Application circuit

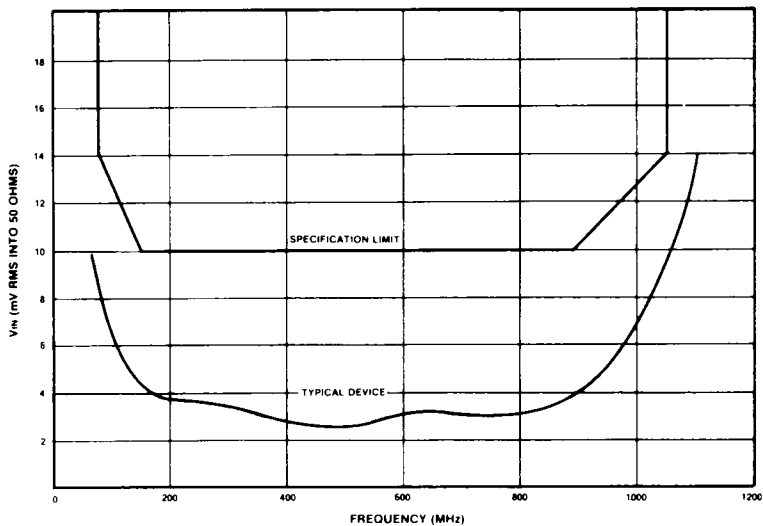

Fig.5 Typical input sensitivity

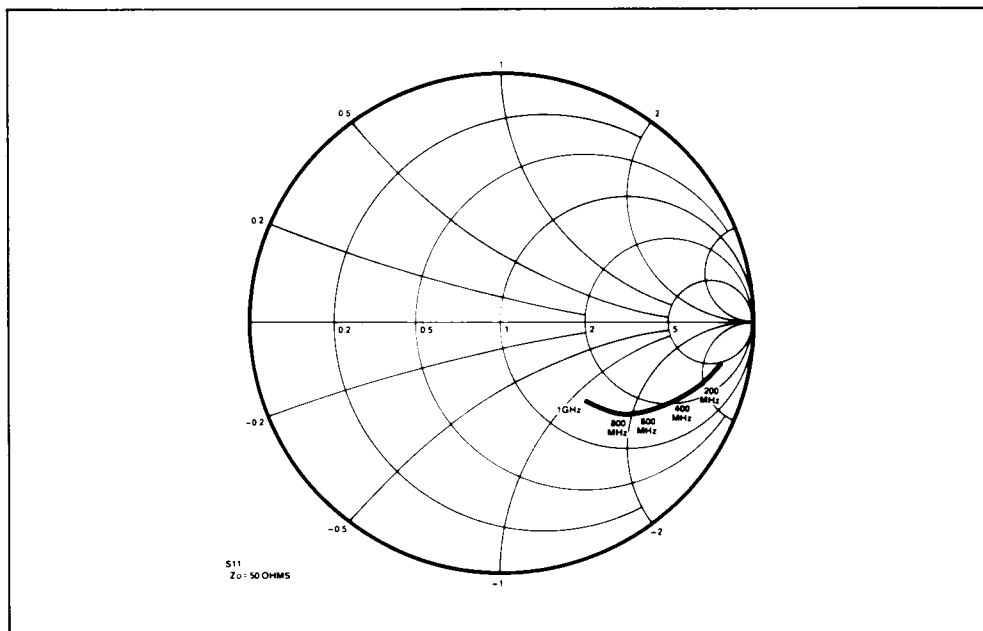

Fig.6 Typical input impedance