

HF Front End for Car Radios and HiFi Receivers

Description

Technology: Bipolar

Features

- Completely integrated FM front end increases quality level and reliability
- High performance due to three AGC loops allow extreme large signal handling
- Fulfils FTZ rules
- Double-balanced high linear mixer with low-noise figure
- Oscillator with low phase noise and excellent frequency stability
- IF preamplifier with dB-linear gain control
- Low noise and high stability of the reference voltage circuit for internal and auxiliary functions

Block Diagram

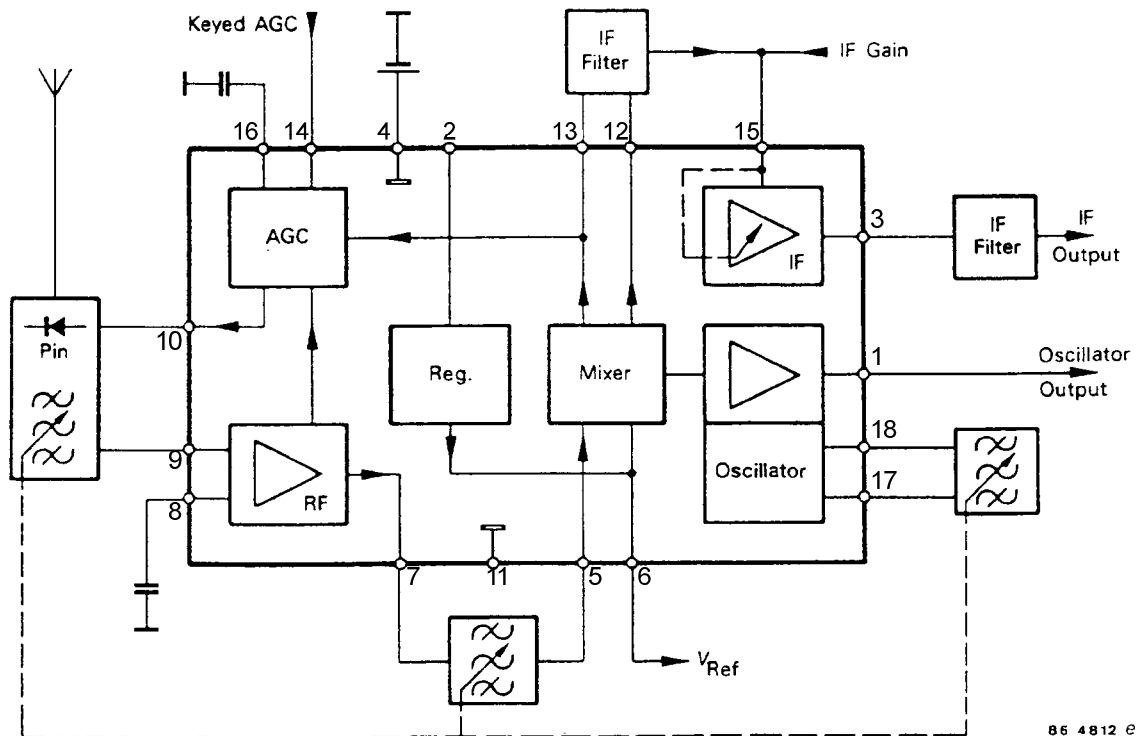

Figure 1. Block diagram

Ordering Information

| Extended Type Number | Package | Remarks |
|----------------------|---------|---------|
| U4062B-B | DIP18 | |

Pin Description

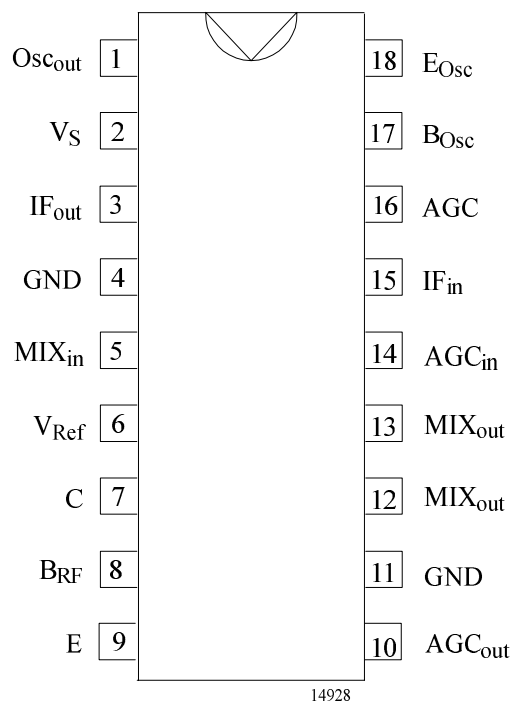

Figure 2. Pinning DIP18

| Pin | Symbol | Function |
|-----|--------------------|----------------------------|
| 1 | Osc _{out} | Oscillator output |
| 2 | V _S | Supply voltage |
| 3 | IF _{out} | IF output |
| 4 | GND | Ground |
| 5 | MIX _{in} | Mixer input |
| 6 | V _{Ref} | Reference voltage output |
| 7 | C | Collector |
| 8 | B _{RF} | Base, RF preamplifier |
| 9 | E | Emitter |
| 10 | AGC _{out} | AGC output |
| 11 | GND | Ground |
| 12 | MIX _{out} | Mixer output |
| 13 | MIX _{out} | Mixer output |
| 14 | AGC _{in} | AGC input (IF strip) |
| 15 | IF _{in} | IF input / IF gain control |
| 16 | AGC | AGC time constant |
| 17 | B _{Osc} | Base oscillator |
| 18 | E _{Osc} | Emitter oscillator |

Absolute Maximum Ratings

Reference point ground, Pins 4 and 11

| Parameters | Symbol | Value | Unit |
|---|------------------|-------------|------|
| Supply voltage Pins 2, 12 and 13 | V _S | 18 | V |
| Power dissipation T _{amb} = 85°C | P _{tot} | 450 | mW |
| Junction temperature | T _j | 125 | °C |
| Storage temperature range | T _{stg} | -50 to +125 | °C |
| Ambient temperature range | T _{amb} | -25 to +85 | °C |

Thermal Resistance

| Parameters | Symbol | Value | Unit |
|------------------|-------------------|-------|------|
| Junction ambient | R _{thJA} | 90 | K/W |

Electrical Characteristics

$V_S = 10\text{ V}$, $f_{iRF} = 50.3\text{ MHz}$, $f_{Osc} \approx 100\text{ MHz}$, $f_{IF} = f_{Osc} - f_{iRF} \approx 49.7\text{ MHz}$, reference point Pins 4 and 11, $T_{amb} = +25^\circ\text{C}$, unless otherwise specified, see test circuit figure 4.

| Parameters | Test Conditions / Pins | Symbol | Min. | Typ. | Max. | Unit |
|--|---|-----------------------------------|------|------|------|------------|
| Supply voltage range | | V_S | 7 | | 16 | V |
| Supply currents | | | | | | |
| Supply current | Pin 2 | I_S | | 11.5 | | mA |
| Mixer | Pins 12 and 13 | $I_{12} + I_{13}$ | | 9 | | mA |
| RF stage | $R_4 = 470\ \Omega$ Pin 7 | I_7 | | 9 | | mA |
| RF preamplifier ($R_{g9} = 50\ \Omega$, $R_{L7} = 200\ \Omega$) | | | | | | |
| DC voltage | Pin 7 | V_7 | | 5.7 | | V |
| | Pin 8 | V_8 | | 0.77 | | V |
| Power gain | | G_{RF} | | 10.5 | | dB |
| Third order intercept | | IP_3 | | 12 | | dBm |
| Dynamic characteristics, $f = 100\text{ MHz}$ | | | | | | |
| Input impedance | | Z_9 | | | 5 | Ω |
| Forward current gain | $ i_7/i_9 $ | h_{fb} | | 1 | | A/A |
| Parallel output resistance | | R_7 | | 3 | | k Ω |
| Parallel output capacitance | | C_1 | | 3.8 | | pF |
| Noise figure | | N_{FRF} | | 2 | | dB |
| Oscillator ($f_{Osc} = 100\text{ MHz}$, unloaded $Q = 80$, resonance resistance $R_{g17} = 250\ \Omega$) | | | | | | |
| DC voltage | Pin 17 | V_{17} | | 3.2 | | V |
| | Pin 18 | V_{18} | | 2.5 | | V |
| Oscillator voltage | Pin 17 | V_{Osc17} | 100 | 130 | | mV |
| Frequency drift | By supply voltage change df_o/dV_S | $\Delta f_{Osc}(V_S)$ | | 1.3 | | kHz/V |
| | By temperature change df_o/dK | $\Delta f_{Osc}(T_j)$ | | 2 | | kHz/K |
| FM noise equivalent deviation, (Ripple voltage < 0.5 mV) | Frequency band 300 Hz to 20 kHz, unweighted | Δf_{noise} | | 5 | | Hz |
| | Peak CCIR | Δf_{noise} | | 10.5 | | Hz |
| | Peak CCIR, weighted with 75 μs , deemphasis | Δf_{noise} | | 4.2 | | Hz |
| FM by AM signal at mixer input | $f_{iRF} = 90\text{ MHz}$, $m = 0.8$, $f_M = 1\text{ kHz}$, $V_{iRF} = 106\text{ dB}\mu\text{V}$ | Δf_{Osc} (V_{iRF}) | | 160 | | Hz |
| Oscillator output buffer ($R_{L1} = 520\ \Omega$) | | | | | | |
| DC current load limitation | Pin 1 | I_1 | | | 0.2 | mA |
| DC voltage | Pin 1 | V_1 | | 1.7 | | V |
| Voltage gain | $V_{Osc17} \leq 200\text{ mV}$ V_{Osc1}/V_{Osc17} Pin 1 | G_{buffer} | | 0.86 | | |
| Harmonics | | | | <-30 | | dBc |
| Output impedance | Pin 1 | Z_1 | | 80 | | Ω |

Electrical Characteristics (continued)

$V_S = 10\text{ V}$, $f_{iRF} = 50.3\text{ MHz}$, $f_{Osc} \approx 100\text{ MHz}$, $f_{IF} = f_{Osc} - f_{iRF} \approx 49.7\text{ MHz}$, reference point Pins 4 and 11,
 $T_{amb} = 25^\circ\text{C}$, unless otherwise specified, see test circuit figure 4.

| Parameters | Test Conditions / Pins | Symbol | Min. | Typ. | Max. | Unit |
|--|--|--------------------|------|-------|------|-------------------|
| Mixer ($R_{g5} = 200\ \Omega$, $R_{L12-13} = 200\ \Omega$) | | | | | | |
| Conversion power gain | | G_C | | 7.5 | | dB |
| Third order intercept | | IP_3 | | 3.5 | | dBm |
| Parallel input resistance | $f = 100\text{ MHz}$ Pin 5 | R_5 | | 5 | | k Ω |
| Parallel input capacitance | $f = 100\text{ MHz}$ Pin 5 | C_5 | | 3 | | pF |
| Parallel output resistance | $f = 10.7\text{ MHz}$, Pins 12, 13 parallel connected | R_{12+13} | | 55 | | k Ω |
| Effective output capacitance between Pin 12 and 13 | $f = 10.7\text{ MHz}$ | C_{12-13} | 2.9 | 3.1 | 3.3 | pF |
| | $V_{12,13} = 10\text{ V}$ | C_{12-13} | 3.25 | 3.5 | 3.75 | pF |
| | $V_{12,13} = 7\text{ V}$ | C_{12-13} | 2.5 | 2.7 | 2.9 | pF |
| | $V_{12,13} = 16\text{ V}$ | C_{12-13} | | | | pF |
| Conversion transconductance | $ i_{12}/u_5 $, $ i_{13}/u_5 $ | g_c | | 5.8 | | m-mho |
| Maximum available conversion power gain | $f_{iRF} = 100\text{ MHz}$, $f_{IF} = 10.7\text{ MHz}$ | MACG | | 43 | | dB |
| Noise figure ($f_{IF} = 10.7\text{ MHz}$) Single side band | $R_{g5}(f_{iRF}) = 450\ \Omega$, $f_{iRF} = f_{Osc} - f_{IF}$ | NF _{CSSB} | | 5.6 | | dB |
| IF preamplifier ($f = 10.7\text{ MHz}$, $R_{L3} = R_{g15} = 200\ \Omega$) | | | | | | |
| DC voltage | Pin 3 | V_3 | | 7.6 | | V |
| Power gain | Maximum control voltage of $V_{15} = 1.6\text{ V}$ is recommended $V_{15} = 1.6\text{ V}$ $V_{15} < 0.8\text{ V}$ | G_{maxIF} | | 24 | | dB |
| | | G_{minIF} | | -4 | | dB |
| Gain control deviation by V_{15} | | ΔG_{IF} | | 28 | | dB |
| External control current | at G_{maxIF} | I_{15max} | | 20 | | μA |
| | at G_{minIF} Pin 15 | I_{15min} | | 0 | | μA |
| Gain control slope | dG_{IF}/dI_{15} | S_{I15} | | 1.3 | | dB/ μA |
| | dG_{IF}/dV_{15} Pin 15 | S_{V15} | | 35 | | dB/V |
| Temperature coefficient of voltage gain | dG_{IF}/dT_j at $V_{15} = 1.6\text{ V}$ $V_{15} < 0.8\text{ V}$ $I_{15} = \text{constant}$ | TCG | | 0 | | dB/K |
| | | | | 0.04 | | dB/K |
| | | | | -0.02 | | dB/K |
| Parallel input resistance | Pin 15 | R_{15} | | 2.4 | | k Ω |
| Parallel input capacitance | Pin 15 | C_{15} | | 5.9 | | pF |
| Parallel output resistance | Pin 3 | R_3 | | 350 | | Ω |
| Parallel output capacitance | Pin 3 | C_3 | | 4.1 | | pF |
| Noise figure | $V_{15} = 1.6\text{ V}$ | NF _{IF} | | 11 | | dB |

Electrical Characteristics (continued)

$V_S = 10\text{ V}$, $f_{iRF} = 50.3\text{ MHz}$, $f_{Osc} \approx 100\text{ MHz}$, $f_{IF} = f_{Osc} - f_{iRF} \approx 49.7\text{ MHz}$, reference point Pins 4 and 11, $T_{amb} = 25^\circ\text{C}$, unless otherwise specified, see test circuit figure 4.

| Parameters | Test Conditions / Pins | Symbol | Min. | Typ. | Max. | Unit |
|--|--|----------------------|------|---------------------------|-------|--|
| AGC circuit (no signal at Pins 5 and 9) | | | | | | |
| DC voltage | Pin 16 | V_{16} | | 1.0 | | V |
| Saturation voltage | Pin 10 | V_{10min} | | 0.08 | 0.2 | V |
| Input current | $V_{14} \cong V_6$ Pin 14 | $-I_{14}$ | | 0.01 | 0.1 | μA |
| Maximum allowable current | Pin 14 | $ \pm I_{14} _{max}$ | | | 50 | μA |
| Maximum control current for external PIN-diode | $I_{10} = 0$ | I_{diode} | | | I_7 | |
| AGC threshold voltages (respecting $V_{10} = 0.25\text{ V}$) | | | | | | |
| RF stage output | Pin 7 | V_{RF7} | | 450 | | mV |
| Mixer-stage output | $V_{14} = V_6$ Pin 13 | V_{IF13} | | 300 | | mV |
| External AGC voltage | $V_{IF13} = 1\text{ V}$ Pin 14 | V_{14min} | | 0.9 | | V |
| Internal AGC voltage | Pin 16 | V_{16min} | | 1.4 | | V |
| Reference voltage source | | | | | | |
| Output voltage, without load | $I_6 = 0$ Pin 6 | V_6 | 1.6 | 1.7 | 1.8 | V |
| Temperature dependence of V_6 | $ V_6 $ $T_{amb} = -25$ to $+85^\circ\text{C}$ | $\Delta V_6(T)$ | | 20 | | mV |
| Internal differential resistance | dV_6/dI_6 when $I_6 = 0\text{ mA}$ | r_{d6} | | 50 | | Ω |
| Ripple rejection | $20 \log (dV_S/dV_6)$ when $I_6 = 0\text{ mA}$ | α_6 | | 65 | | dB |
| Noise voltage / $\sqrt{\text{Hz}}$ | when $I_6 = 0$ and f = 25 Hz f = 125 Hz f = 1 kHz f = 10 kHz | | | 0.6 0.37 0.1 0.1 | | μV μV μV μV |

Test Circuit

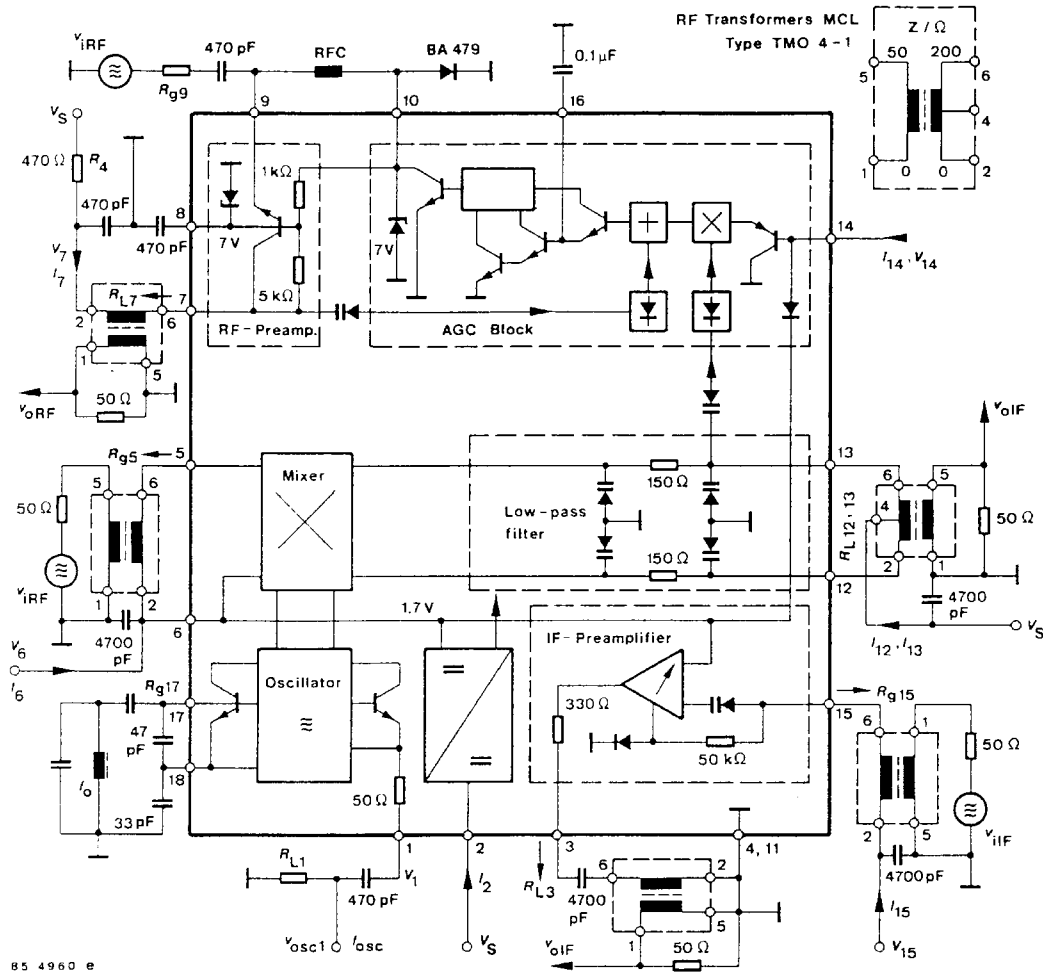

Figure 3. Test circuit

RF Preamplifier

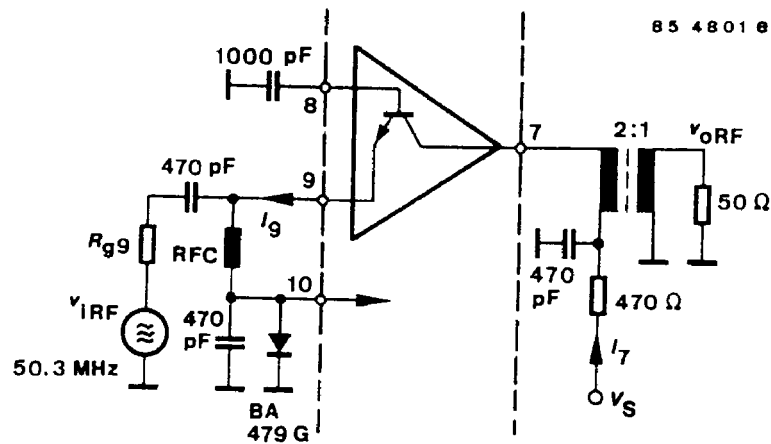

Figure 4. Test circuit

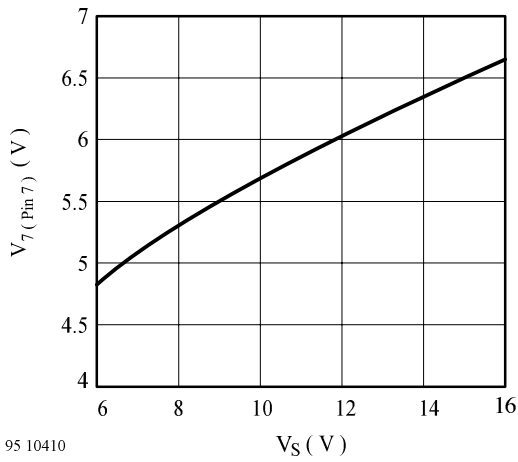

Figure 5. V_7 vs. V_S

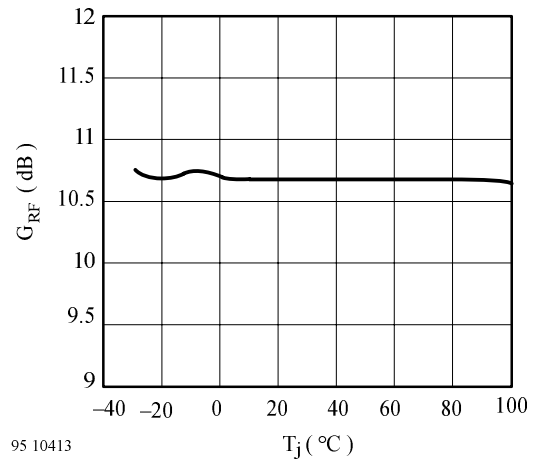

Figure 8. G_{RF} vs. T_j

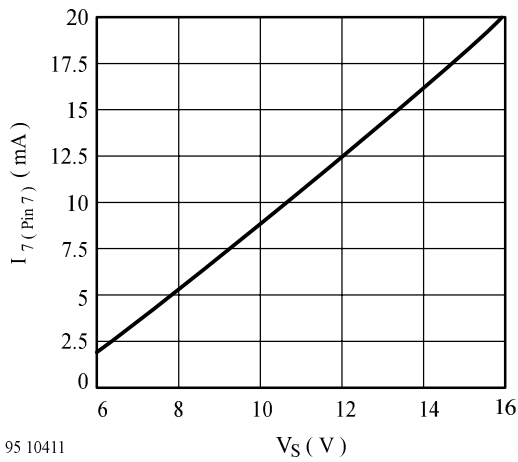

Figure 6. I_7 vs. V_S

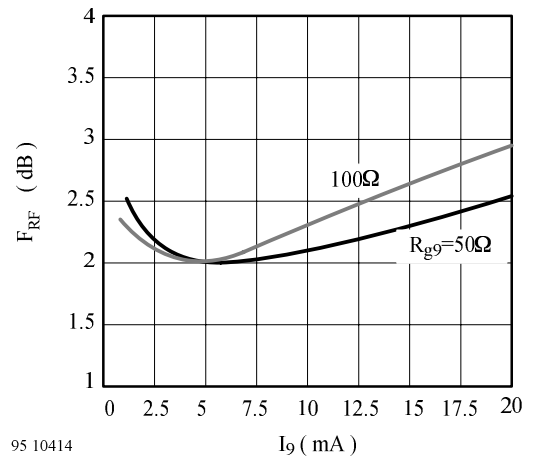

Figure 9. F_{RF} vs. I_g

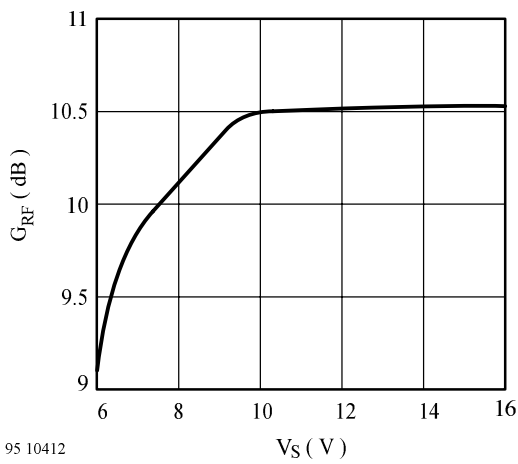

Figure 7. G_{RF} vs. V_S

Oscillator/ Oscillator Output Buffer

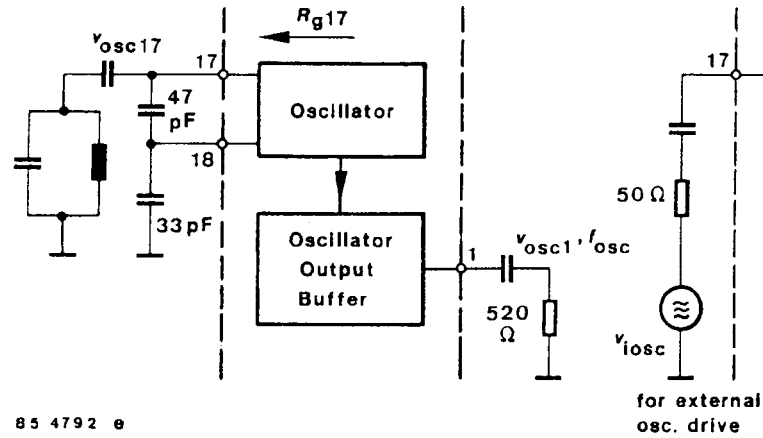

Figure 10. Test circuit – free running oscillator frequency $f_{osc} \approx 100$ MHz

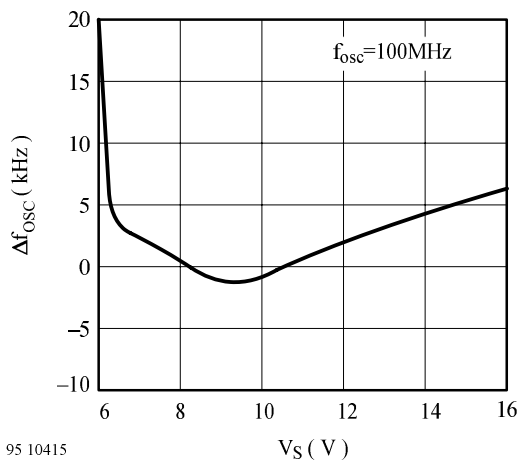

Figure 11. Δf_{osc} vs. V_S

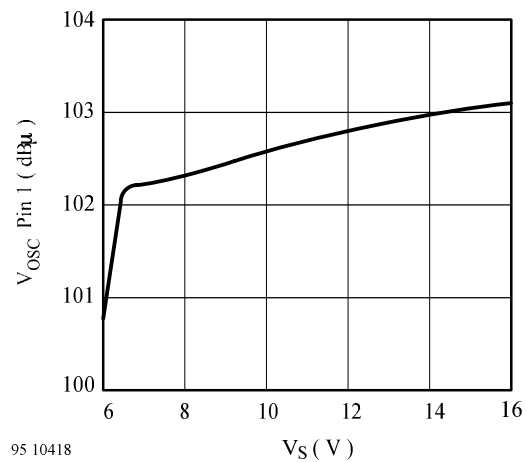

Figure 13. V_{osc} vs. V_S

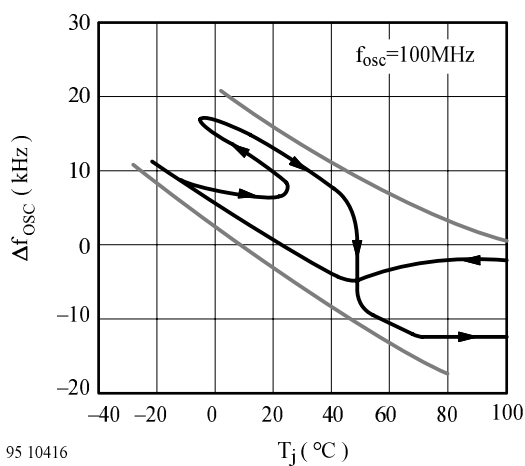

Figure 12. Δf_{osc} vs. T_j

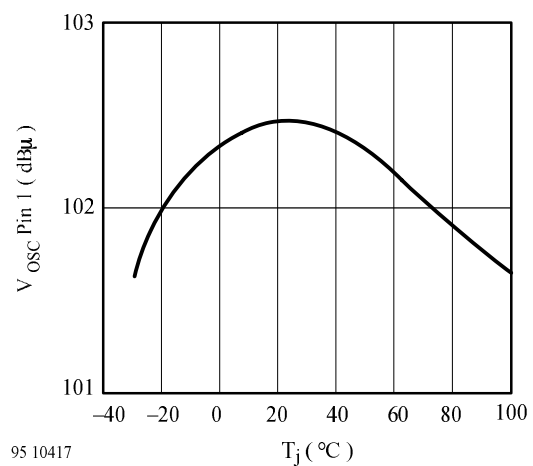

Figure 14. V_{osc} vs. T_j

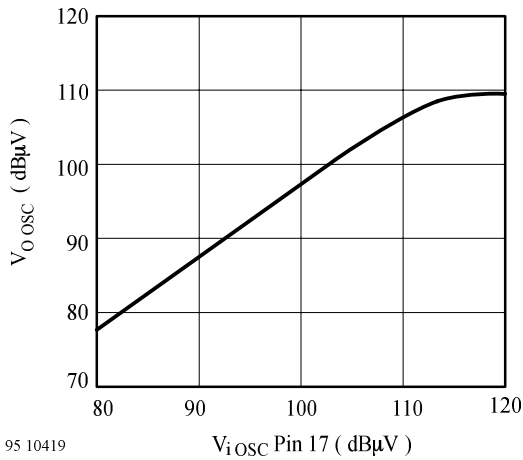

Figure 15. V_{Osc} vs. V_{iOsc}

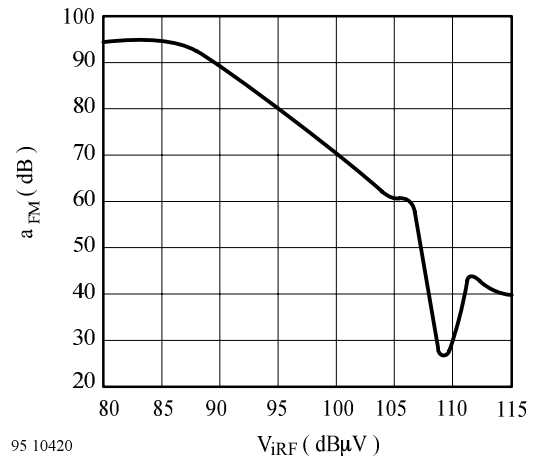
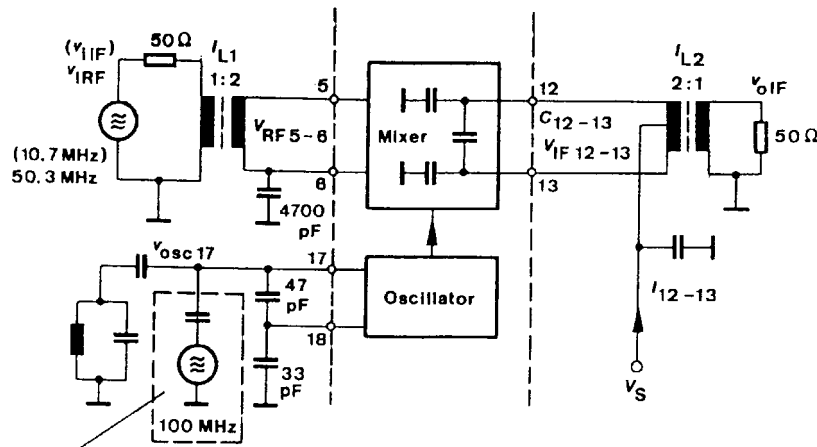

Figure 16. a_{FM} vs. V_{iRF}

Mixer



For test's versus v_{osc17} only

Figure 17. Test circuit

I_{L1} , I_{L2} = Insertion loss of the RF transformers

Conversion power gain $G_C = 20 \log (2 V_{oIF}/V_{iRF}) + I_{L1} \text{ (dB)} + I_{L2} \text{ (dB)}$

$V_{RF5-6} \text{ (dB}\mu\text{V)} = V_{iRF} \text{ (dB}\mu\text{V)} - I_{L1} \text{ (dB)} + 6$

$V_{IF12-13} \text{ (dB}\mu\text{V)} = V_{oIF} \text{ (dB}\mu\text{V)} - I_{L2} \text{ (dB)} + 6$

$\Delta G_C = G_C (V_{OSC17}) - G_C \text{ (nominal)}$

Input to output IF isolation

$a_{IF} = 20 \log (2 V_{oIF}/V_{iIF}) + I_{L1} \text{ (dB)} + I_{L2} \text{ (dB)} - G_C \text{ (nominal)}$

Characteristics α_{FM} versus v_{iRF} , see previous page

Oscillator frequency immunity against amplitude modulated signal at mixer input (Pin 5-6) related to FM standard modulation:

$\alpha_{FM} = 20 \log [75 \text{ kHz}/\Delta f_{OSC}(v_{iRF})]$ whereas

v_{iRF} = mixer input signal ($f_{iRF} = 89.3 \text{ MHz}$, $m = 0.8$, $f_M = 1 \text{ kHz}$)

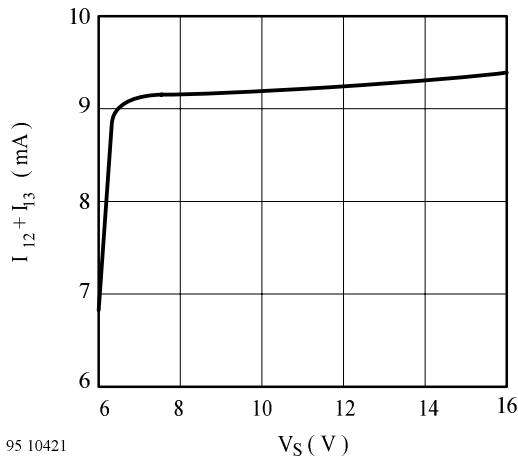

Figure 18. $I_{12} + I_{13}$ vs. V_S

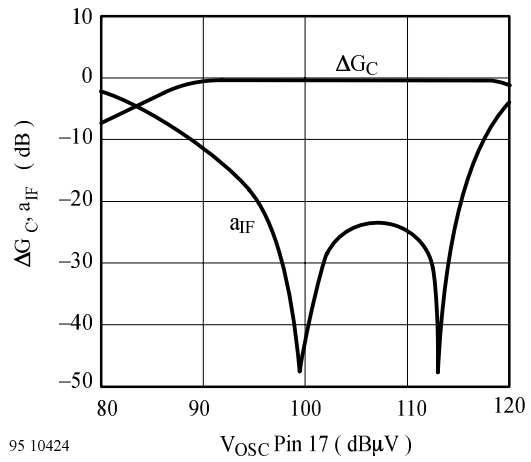

Figure 21. ΔG_C , a_{IF} vs. V_{Osc} Pin 17

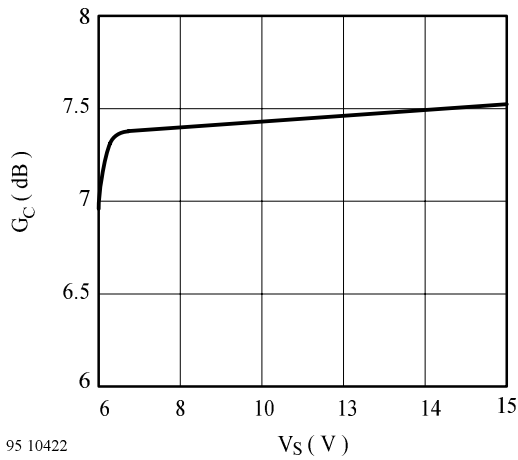

Figure 19. G_C vs. V_S

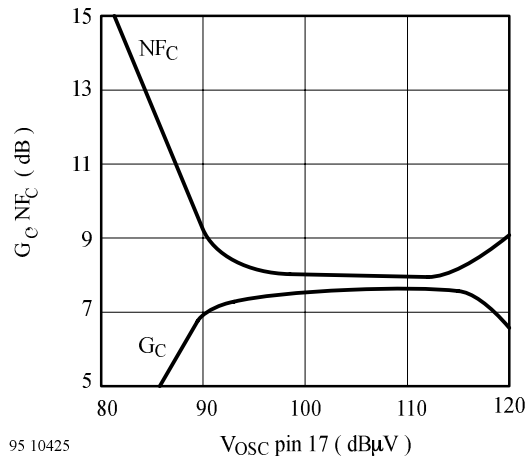

Figure 22. G_C NFC vs. V_{Osc} Pin 17

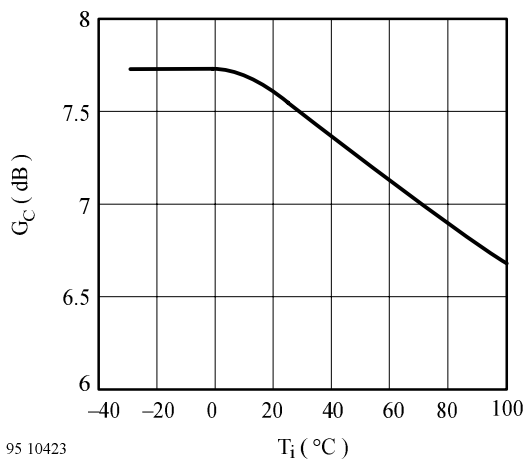

Figure 20. G_C vs. T_j

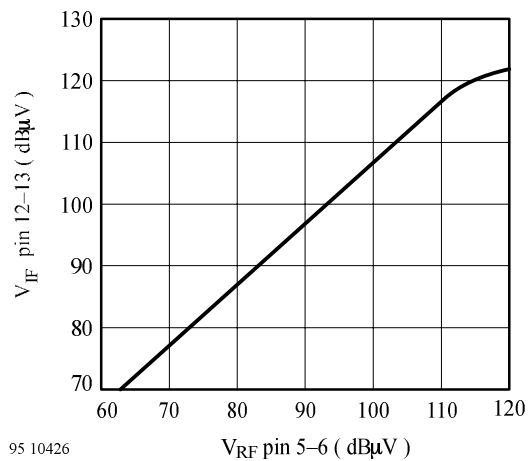

Figure 23. V_{IF} Pin 5-6 vs. V_{RF} Pin 5-6

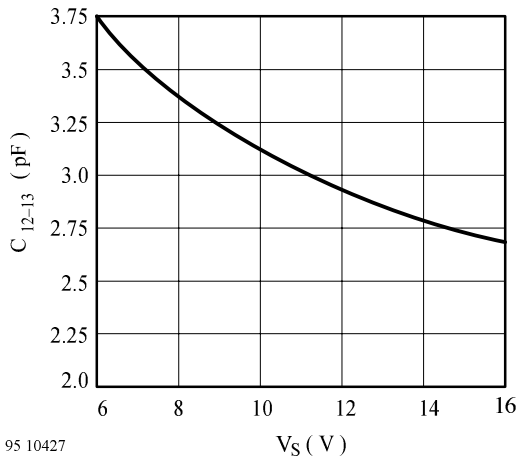

Figure 24. C_{12-13} vs. V_S

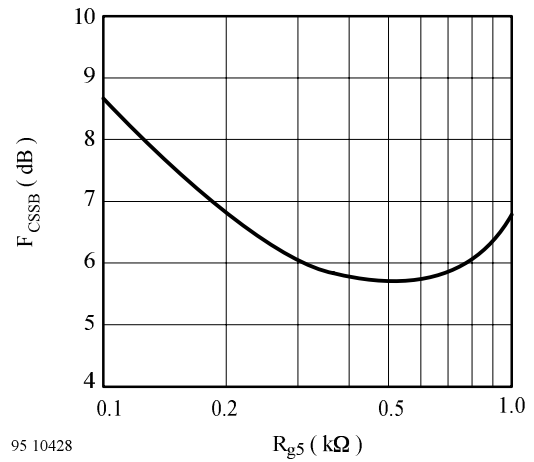
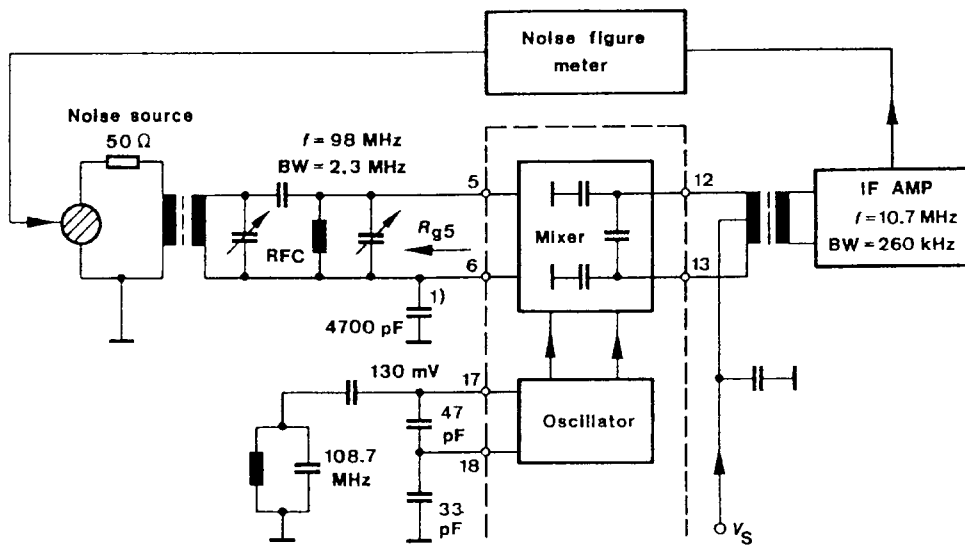

Figure 25.
 F_{CSSB} = Noise figure reading /dB- I_L /dB
 I_L = Insertion loss of the tuned transformer network



1) Mounted as close as possible between pin 6 and Ground

85 4950 e

Figure 26. Test circuit for single sideband noise (F_{CSSB})

AGC Circuit

I_{L1}, I_{L2} = Insertion loss of the RF transformers,
 $V_{RF7} \text{ (dB}\mu\text{V)} = V_{IRF} \text{ (dB}\mu\text{V)} - I_{L1} \text{ (dB)} + 6$
 $V_{IF13} \text{ (dB}\mu\text{V)} = V_{IIF} \text{ (dB}\mu\text{V)} - I_{L2} \text{ (dB)}$

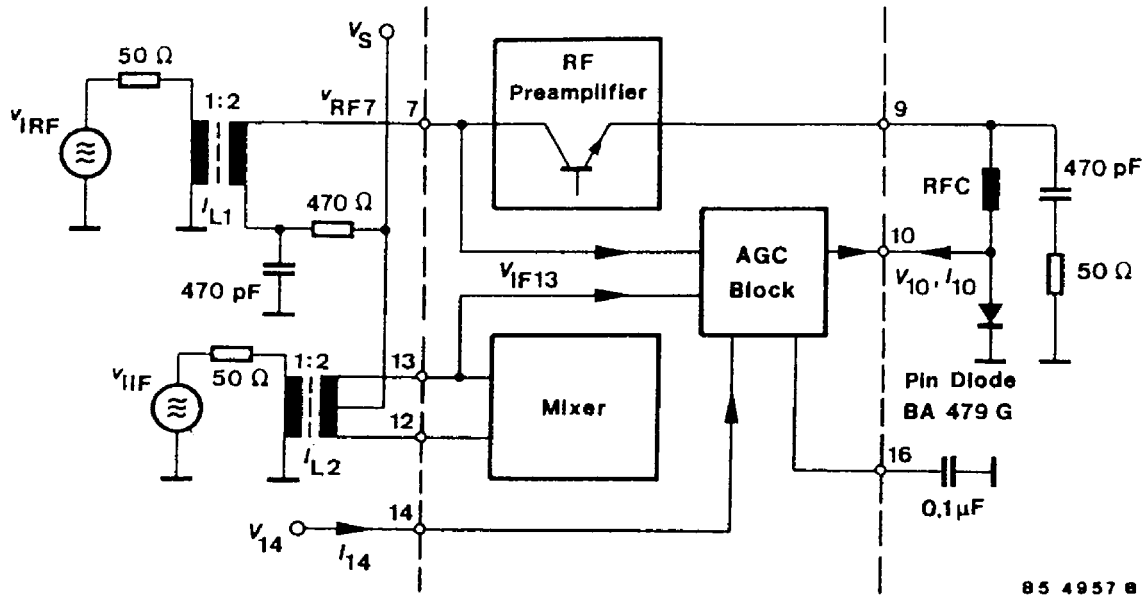

Figure 27. Test circuit

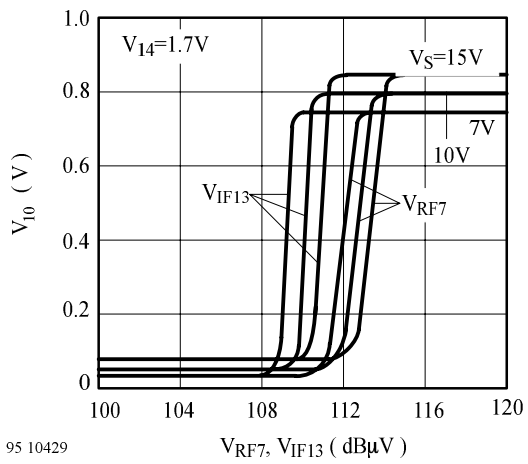

Figure 28. V_{I0} vs. V_{RF7}, V_{IF13}

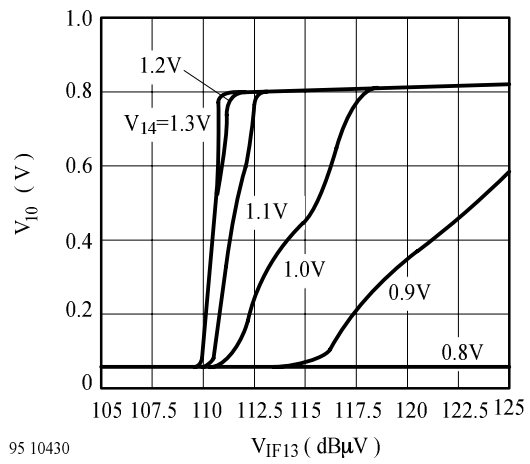

Figure 29. V_{I0} vs. V_{IF13}

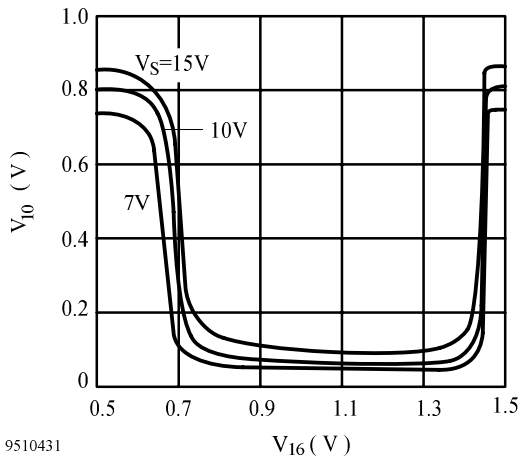

Figure 30. V_{10} vs. V_{16}

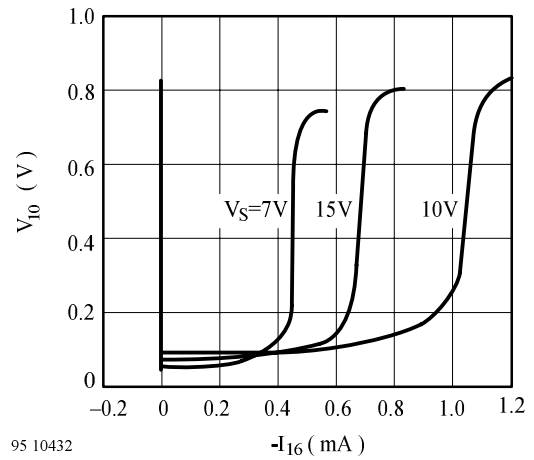

Figure 31. V_{10} vs. $-I_{16}$

IF Pre-amplifier

I_{L1}, I_{L2} = Insertion loss of the RF transformers
 Power gain $G_F = 20 \log (2 V_{oIF}/V_{iRF}) + I_{L1} \text{ (dB)} + I_{L2} \text{ (dB)}$
 $V_{iIF15} \text{ (dB}\mu\text{V)} = V_{iIF} \text{ (dB}\mu\text{V)} - I_{L1} \text{ (dB)} + 6$
 $V_{oIF3} \text{ (dB}\mu\text{V)} = V_{oIF} \text{ (dB}\mu\text{V)} - I_{L2} \text{ (dB)} + 6$

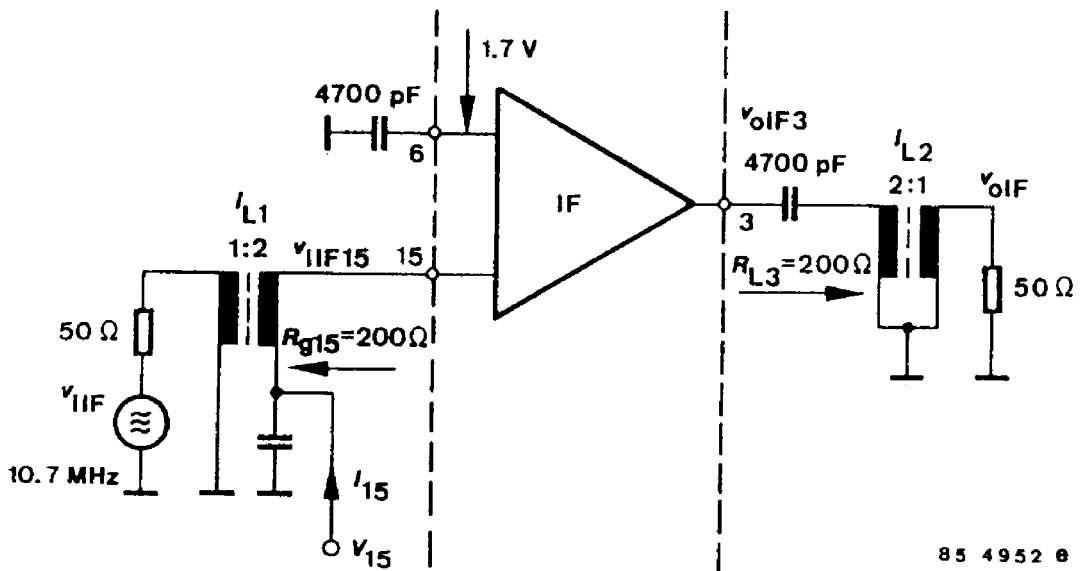

Figure 32. Test circuit

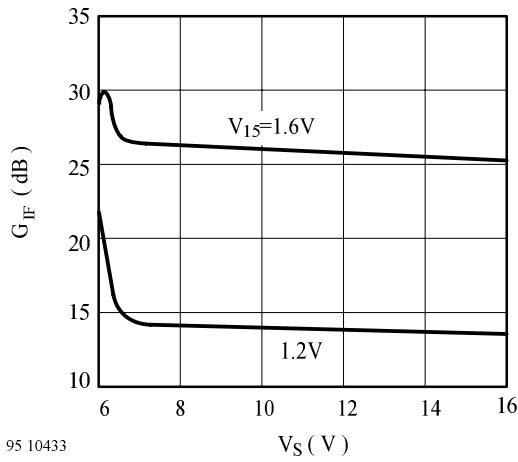

Figure 33. G_{IF} vs. V_S

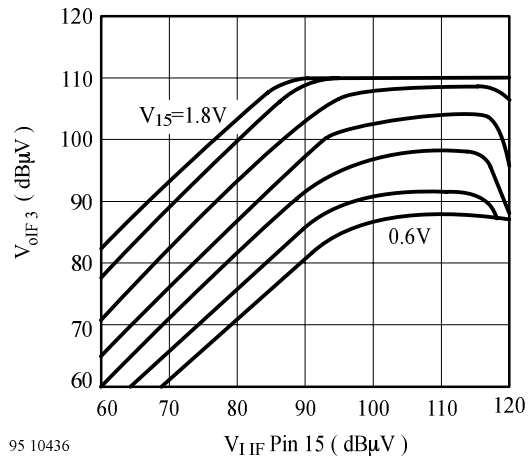

Figure 36. V_{oIF3} vs. V_{IIF} Pin 15

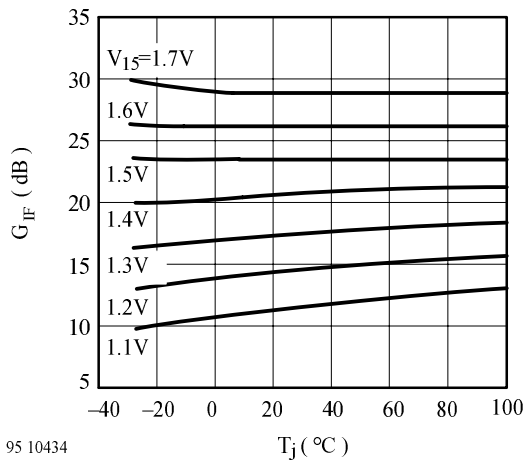

Figure 34. G_{IF} vs. T_j

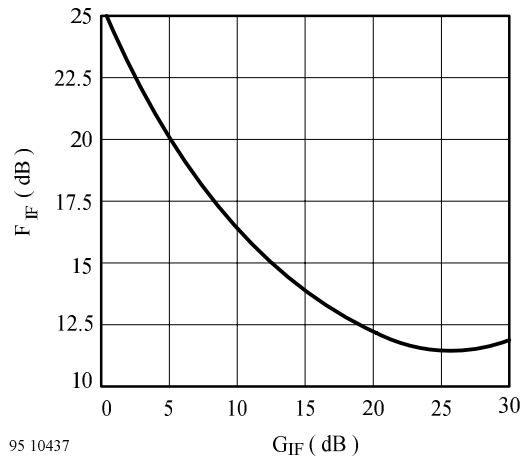

Figure 37. F_{IF} vs. G_{IF}

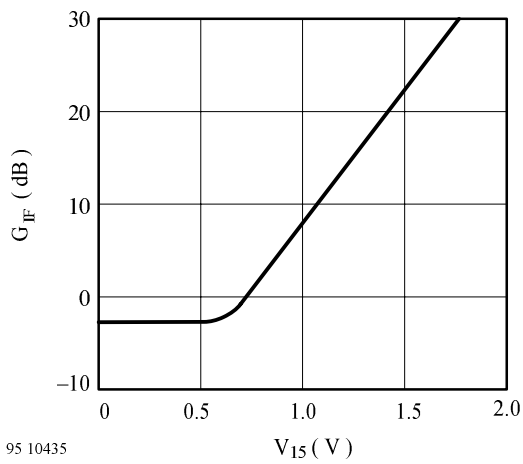

Figure 35. G_{IF} vs. V_{15}

Reference Voltage

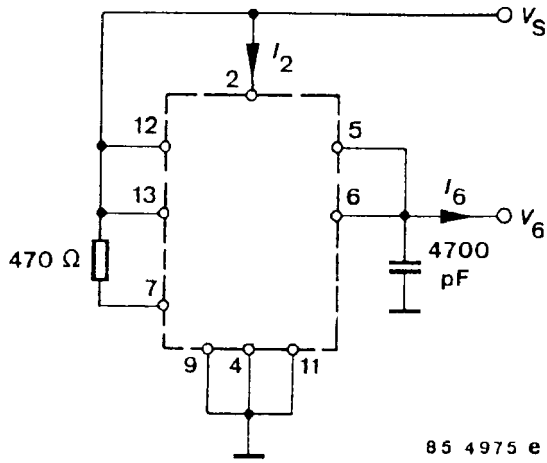

Figure 38. Test circuit

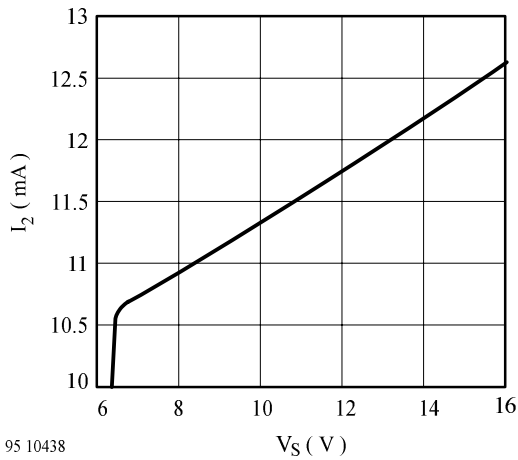

Figure 39. I_2 vs. V_S

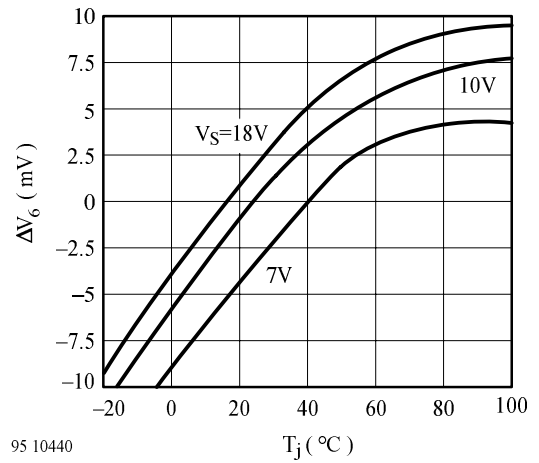

Figure 41. ΔV_6 vs. T_j

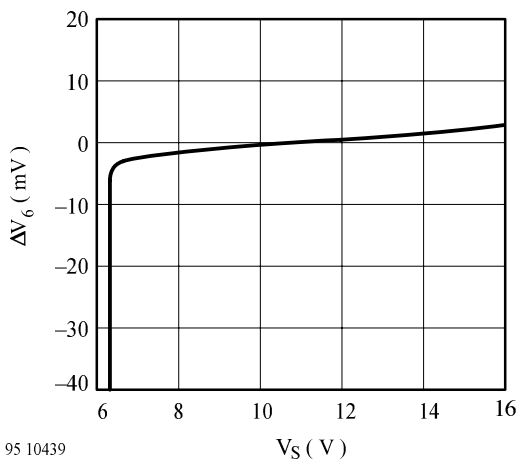

Figure 40. ΔV_6 vs. V_S

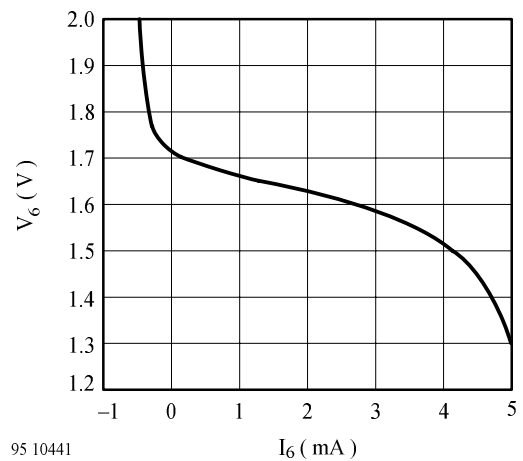
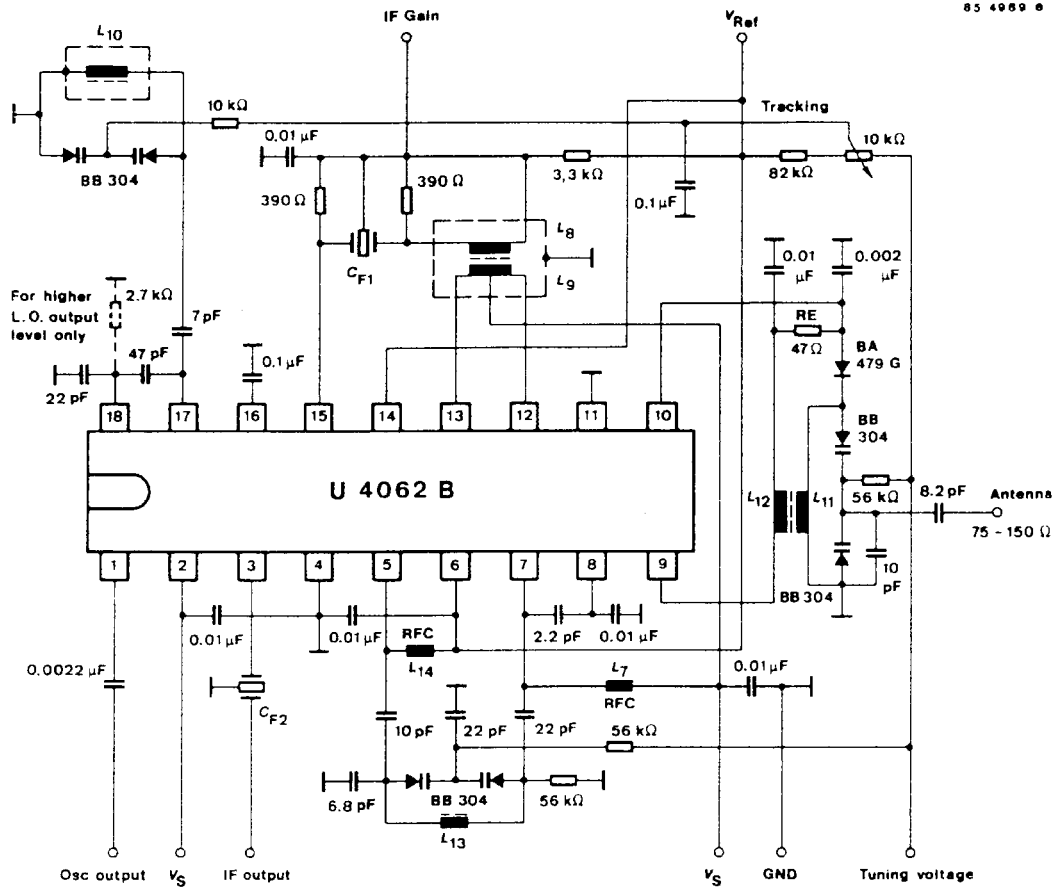

Figure 42. V_6 vs. I_6

Application Circuit



Circuit (section) from above diagram with keyed AGC

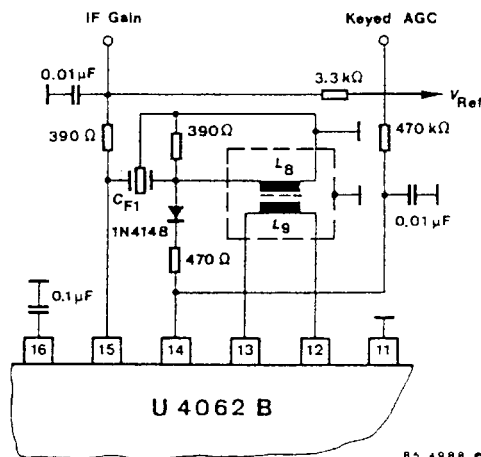

Figure 43. Typical Application circuit for high performance FM front end using non-repetitive alignment concept

Coils Specifications

| | |
|-----------------------------------|--|
| L ₈ /L ₉ | Toko 7 PL9/ (18 + 18) turns Nr. 218 ANS – 788 N |
| L ₁₀ | Toko 7 K1 3 turns Nr. 291 ENS – 2054 IB or Toko MC 122 Nr. E528 SNAS – 100075 |
| L ₁₁ /L ₁₂ | Toko 7 K1 without case 4/8 turns Nr. 291 ENF – 2342 x |
| L ₁₃ | Toko 7 K1 4 turns Nr. 291 ENS – 2341 IB or Toko MC 122 Nr. E528 SNAS – 100076 |
| L ₁₄ /L ₁₇ | Choke 1.5 μH Toko 348 LS – 1R5 or similar |
| CF ₁ ; CF ₂ | Toko CFSK – 107M3 or similar |

V_S = 8.5 V, T_{amb} = 25°C

| Electrical Connections | Pin DIP18 | Voltage (DC) in V |
|--------------------------------|--------------|----------------------|
| LO output | 1 | 1.73 |
| V _S | 2 | 8.5 |
| IF output | 3 | 6.1 |
| Ground | 4 | 0 |
| Mixer input | 5 | 1.7 |
| Reference output voltage | 6 | 1.7 |
| RF preamplifier (collector) | 7 | 8.5 |
| RF preamplifier (base) | 8 | 1.3 |
| RF preamplifier (emitter) | 9 | 0.53 |
| AGC output | 10 | 0.07 |
| Ground | 11 | 0 |
| Mixer output | 12 | 8.5 |
| Mixer output | 13 | 8.5 |
| AGC input | 14 | 1.7 |
| IF input, IF gain control | 15 | 1.54 |
| AGC time constant | 16 | 1.06 |
| LO (base) | 17 | 3.2 |
| LO (emitter) | 18 | 2.51 |

FM Front End Data Using Application Circuit

Antenna impedance 75 Ω, Z_{load IF} = 330 Ω, V_S = 8.5 V, T_{amb} = 25°C

| Characteristics | Symbol | Min. | Typ. | Max. | Unit |
|--|--|------|------------|------|--------|
| Supply current | I _S | | 32 | | mA |
| Tuning range | f | 88 | | 108 | MHz |
| Tuning voltage – at 88 MHz (equal IC's reference voltage) – at 108 MHz | V _{tune} V _{tune} | | 1.7 6.5 | | V V |
| Center IF | f | | 10.7* | | MHz |
| IF output bandwidth at –3 dB | B _{IF} | | 130* | | kHz |
| Power gain | G | | 46* | | dB |
| Gain variation versus the band | ΔG | | 1 | | dB |
| Noise figure | NF | | 6 | | dB |
| Image rejection | | 57 | 70 | | dB |
| RF intermodulation | | | 70 | | dB |
| 1/2 IF rejection | | | 90 | | dB |
| Spurious response, second osc. harmonic | | | 90 | | dB |
| IF rejection | | 85 | | | dB |
| Osc. output voltage at 520 Ω load | V _{OSC} | | 200 | | mV |

* Depending on ceramic IF filters to be used

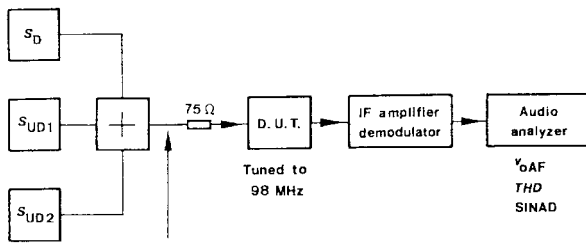

$V_{iD}(f_D)$ = Desired signal (EMF)
 $V_{iUD1}(f_{UD1})$
 $V_{iUD2}(f_{UD2})$ } = Undesired signals (EMF)

Figure 44. Block diagram of the test set up

Test conditions

- De-emphasis - 75 μ s
- AF bandwidth 30 to 20 kHz
- RMS, unweighted

Setup for one signal measurement

- $f_D = 98$ MHz

Note: V_{oAF} related to 75 kHz dev., 1 kHz, $V_{iD} = 66$ dB μ V

Setup for three signals intermodulation measurement

- S_D : $f_D = 98$ MHz, FM: 1 kHz, 22.5 kHz dev.
- S_{UD1} : FM: 0.15 kHz, 22.5 kHz dev.
- S_{UD2} : Unmodulated
- V_{iD} : for 35 dB SINAD

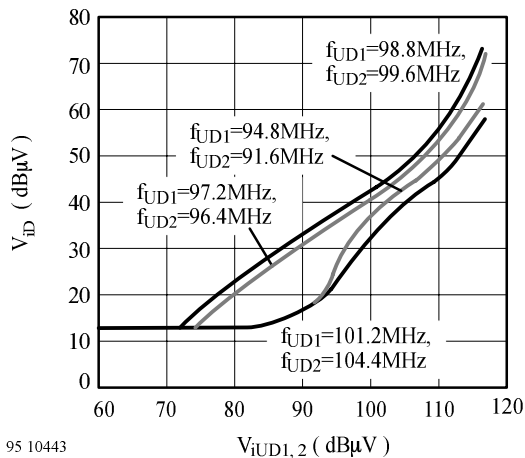

95 10443

Figure 45. V_{iD} vs. $V_{iUD1,2}$
 V_{iD} = input desired, V_{iUD} = input undesired

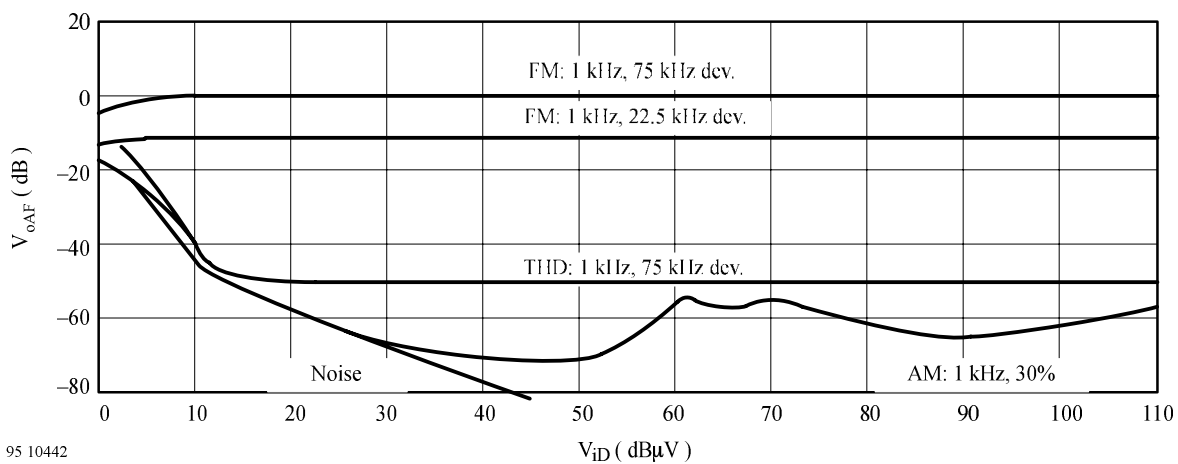

95 10442

Figure 46. V_{oAF} vs. V_{iD}

VHF/UHF-Application

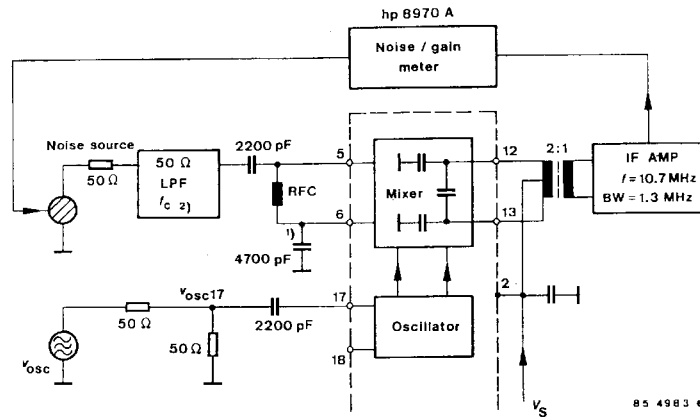

- 1) Mounted as close as possible between Pin 6 and Ground
 2) Cut off frequency, f_c adjustment: $(f_{osc} + f_{IF}) < f_c < (2 f_{osc} - f_{IF})$

Figure 47. Test circuit for conversion gain and noise measurement

Mixer, VHF Characteristics

Test conditions: $R_{g5} = 50 \Omega$, $R_{L12-13} = 200 \Omega$, $V_S = 10 V$
 $f_{IF} = 10.7 \text{ MHz}$, $f_{IRF} = 200 \text{ MHz}$, $f_{OSC} = f_{IRF} + f_{IF}$, $V_{OSC17} = 140 \text{ mV}$

| Parameter | Symbol | Typ. | Unit |
|---|------------|------|----------|
| Conversion power gain, $f_{IF} = 10.7 \text{ MHz}$ | G_C | 2.5 | dB |
| $f_{IF} = 70 \text{ MHz}$ | G_C | 2.3 | dB |
| Double side band noise figure $f_{OSC} = 200 \text{ MHz}$ | NF_{DSB} | 8.2 | dB |
| 3rd order intercept input signal level | IP_3 | 5.5 | dBm |
| Parallel input resistance, Pin 5, $f = 200 \text{ MHz}$ | R_{p5} | 1500 | Ω |
| Parallel input capacitance, Pin 5, $f = 200 \text{ MHz}$ | C_{p5} | 3.3 | pF |
| Parallel input resistance, Pin 17, $f = 200 \text{ MHz}$ | R_{p17} | 4000 | Ω |
| Parallel input capacitance, Pin 17, $f = 200 \text{ MHz}$ | C_{p17} | 2.7 | pF |
| Conversion transconductance | G_C | 6.4 | m-mho |

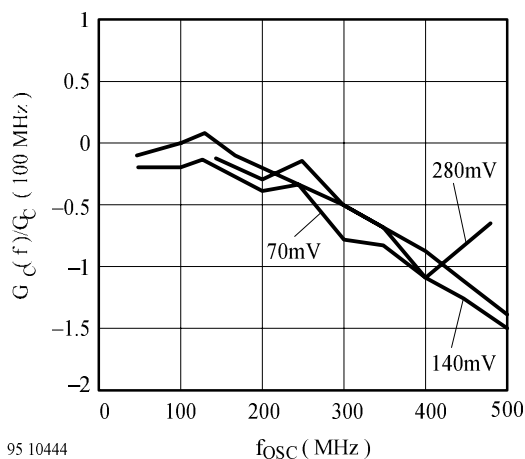

Figure 48. G_C vs. f_{osc}

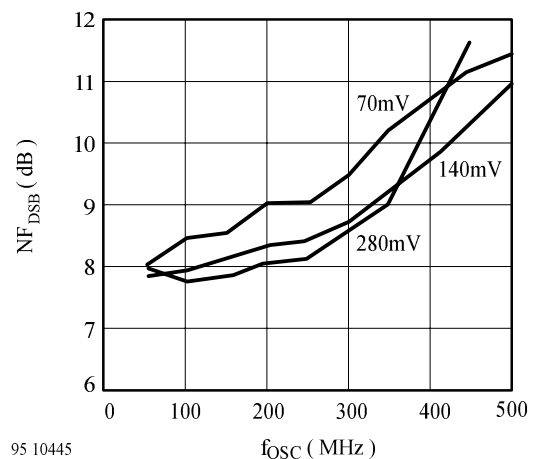
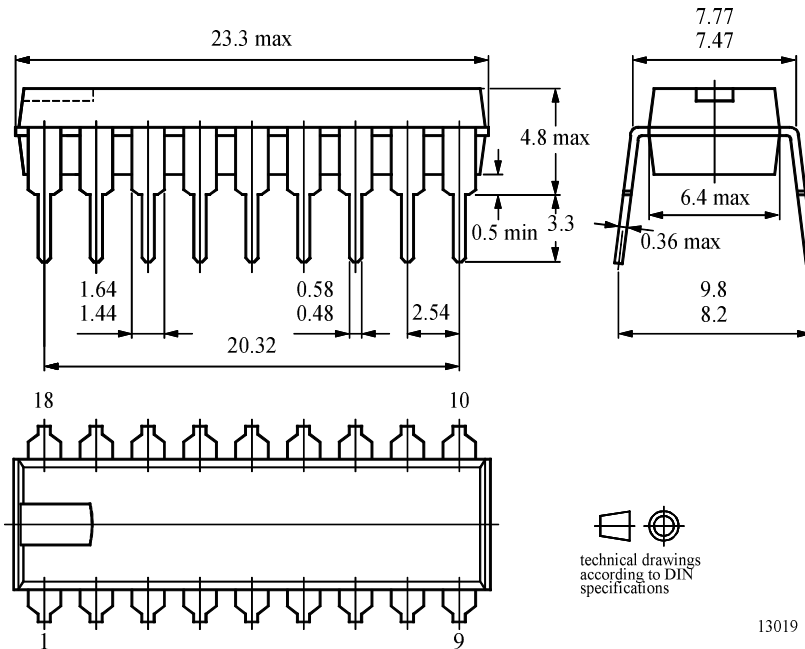

Figure 49. NF_{DSB} vs. f_{osc}

Package Information

Package DIP18

Dimensions in mm



13019

Ozone Depleting Substances Policy Statement

It is the policy of TEMIC Semiconductor GmbH to

1. Meet all present and future national and international statutory requirements.
2. Regularly and continuously improve the performance of our products, processes, distribution and operating systems with respect to their impact on the health and safety of our employees and the public, as well as their impact on the environment.

It is particular concern to control or eliminate releases of those substances into the atmosphere which are known as ozone depleting substances (ODSs).

The Montreal Protocol (1987) and its London Amendments (1990) intend to severely restrict the use of ODSs and forbid their use within the next ten years. Various national and international initiatives are pressing for an earlier ban on these substances.

TEMIC Semiconductor GmbH has been able to use its policy of continuous improvements to eliminate the use of ODSs listed in the following documents.

1. Annex A, B and list of transitional substances of the Montreal Protocol and the London Amendments respectively
2. Class I and II ozone depleting substances in the Clean Air Act Amendments of 1990 by the Environmental Protection Agency (EPA) in the USA
3. Council Decision 88/540/EEC and 91/690/EEC Annex A, B and C (transitional substances) respectively.

TEMIC Semiconductor GmbH can certify that our semiconductors are not manufactured with ozone depleting substances and do not contain such substances.

We reserve the right to make changes to improve technical design and may do so without further notice.

Parameters can vary in different applications. All operating parameters must be validated for each customer application by the customer. Should the buyer use TEMIC Semiconductors products for any unintended or unauthorized application, the buyer shall indemnify TEMIC Semiconductors against all claims, costs, damages, and expenses, arising out of, directly or indirectly, any claim of personal damage, injury or death associated with such unintended or unauthorized use.

TEMIC Semiconductor GmbH, P.O.B. 3535, D-74025 Heilbronn, Germany
Telephone: 49 (0)7131 67 2594, Fax number: 49 (0)7131 67 2423