

**OBSOLETE PRODUCT
NO RECOMMENDED REPLACEMENT**
contact our Technical Support Center at
1-888-INTERSIL or www.intersil.com/tsc

November 19, 2004

FN2914.6

150MHz, Fast Settling Operational Amplifier

The HA-5195 is a operational amplifier featuring a combination of speed, precision, and bandwidth. Employing monolithic bipolar construction coupled with Dielectric Isolation, this device is capable of delivering 200V/μs slew rate with a settling time of 70ns (0.1%, 5V output step). This truly differential amplifier is designed to operate at gains ≥ 5 without the need for external compensation. Other outstanding features are 150MHz gain bandwidth product and 6.5MHz full power bandwidth. In addition to these dynamic characteristics, this amplifier also has excellent input characteristics such as 3mV offset voltage and 6.0nV/√Hz input voltage noise at 1kHz.

With 200V/μs slew rate and 70ns settling time, the HA-5195 is an ideal output amplifier for accurate, high speed D/A converters or the main components in high speed sample/hold circuits. The 5195 is also ideally suited for a variety of pulse and wideband video amplifiers. Please refer to Application Notes AN525 and AN526 for some of these application designs.

At temperatures above 75°C a heat sink is required for the HA-5195 (see Note 2 and Application Note AN556).

Part Number Information

PART NUMBER	TEMP. RANGE (°C)	PACKAGE	PKG. DWG. #
HA1-5195-5	0 to 75	14 Ld CERDIP	F14.3

Features

- Fast Settling Time (0.1%) 70ns
- Very High Slew Rate 200V/μs
- Wide Gain-Bandwidth ($A_V \geq 5$) 150MHz
- Full Power Bandwidth 6.5MHz
- Low Offset Voltage 3mV
- Input Noise Voltage 6nV/√Hz
- Bipolar D.I. Construction

Applications

- Fast, Precise D/A Converters
- High Speed Sample-Hold Circuits
- Pulse and Video Amplifiers
- Wideband Amplifiers

Pinout

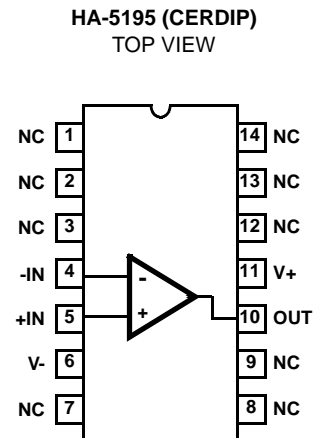

HA-5195

Absolute Maximum Ratings $T_A = 25^\circ\text{C}$

Supply Voltage (V_+ to V_-)	35V
Differential Input Voltage	6V
Output Current	50mA (Peak)

Thermal Information

Thermal Resistance (Typical, Note 2)	θ_{JA} ($^\circ\text{C}/\text{W}$)	θ_{JC} ($^\circ\text{C}/\text{W}$)
CERDIP Package	75	20
Maximum Junction Temperature (Hermetic Package, Note 1)	175 $^\circ\text{C}$	
Maximum Storage Temperature Range	-65 $^\circ\text{C}$ to 150 $^\circ\text{C}$	
Maximum Lead Temperature (Soldering 10s)	300 $^\circ\text{C}$	

Operating Conditions

Temperature Range 0 $^\circ\text{C}$ to 75 $^\circ\text{C}$

CAUTION: Stresses above those listed in "Absolute Maximum Ratings" may cause permanent damage to the device. This is a stress only rating and operation of the device at these or any other conditions above those indicated in the operational sections of this specification is not implied.

NOTES:

- Heat sinking may be required, especially at $T_A \geq 75^\circ\text{C}$.
- θ_{JA} is measured with the component mounted on an evaluation PC board in free air.

Electrical Specifications $V_{\text{SUPPLY}} = \pm 15\text{V}$, Unless Otherwise Specified

PARAMETER	TEST CONDITIONS	TEMP ($^\circ\text{C}$)	MIN	TYP	MAX	UNITS
INPUT CHARACTERISTICS						
Offset Voltage		25	-	3	6	mV
		Full	-	-	10	mV
Average Offset Voltage Drift		Full	-	20	-	$\mu\text{V}/^\circ\text{C}$
Bias Current		25	-	5	15	μA
		Full	-	-	20	μA
Offset Current		25	-	1	4	μA
		Full	-	-	6	μA
Input Resistance		25	-	10	-	$\text{k}\Omega$
Input Capacitance		25	-	1	-	pF
Common Mode Range		Full	± 5	-	-	V
Input Noise Current	$f = 1\text{kHz}$, $R_G = 0\Omega$	25	-	5	-	$\text{pA}/\sqrt{\text{Hz}}$
Input Noise Voltage	$f = 1\text{kHz}$, $R_G = 0\Omega$	25	-	6	-	$\text{nV}/\sqrt{\text{Hz}}$
TRANSFER CHARACTERISTICS						
Large Signal Voltage Gain (Note 3)		25	10	30	-	kV/V
		Full	5	-	-	kV/V
Common Mode Rejection Ratio	$\Delta V_{\text{CM}} = \pm 5\text{V}$	Full	74	95	-	dB
Minimum Stable Gain		25	5	-	-	V/V
Gain-Bandwidth-Product	$V_{\text{OUT}} = 90\text{mV}$, $A_V = 10$	25	150	-	-	MHz
OUTPUT CHARACTERISTICS						
Output Voltage Swing (Note 3)		Full	± 5	± 8	-	V
Output Current (Note 3)		25	± 25	± 30	-	mA
Output Resistance	Open Loop	25	-	30	-	Ω
Full Power Bandwidth (Notes 3, 4)		25	5	6.5	-	MHz
TRANSIENT RESPONSE (Note 5)						
Rise Time		25	-	13	18	ns
Overshoot		25	-	8	-	%
Slew Rate		25	160	200	-	$\text{V}/\mu\text{s}$
Settling Time (Note 5)	5V Step to 0.1%	25	70	-	-	ns
	5V Step to 0.01%	25	-	100	-	ns
	2.5V Step to 0.1%	25	-	50	-	ns
	2.5V Step to 0.01%	25	-	80	-	ns
POWER SUPPLY CHARACTERISTICS						
Supply Current		Full	-	19	28	mA

Electrical Specifications $V_{SUPPLY} = \pm 15V$, Unless Otherwise Specified (Continued)

PARAMETER	TEST CONDITIONS	TEMP (°C)	MIN	TYP	MAX	UNITS
Power Supply Rejection Ratio	$\Delta V_S = \pm 10V$ to $\pm 20V$	Full	70	90	-	dB

NOTES:

3. $R_L = 200\Omega$, $C_L < 10pF$, $V_{OUT} = \pm 5V$.
4. Full power bandwidth guaranteed based on slew rate measurement using: $FPBW = \frac{\text{Slew Rate}}{2\pi V_{PEAK}}$.
5. Refer to Test Circuits section of the data sheet.

Test Circuits and Waveforms

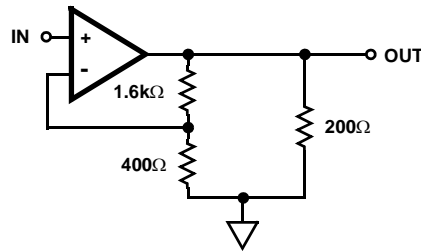

- NOTES:
6. $A_V = 5$.
 7. $C_L < 10pF$.

FIGURE 1. LARGE AND SMALL SIGNAL RESPONSE TEST CIRCUIT

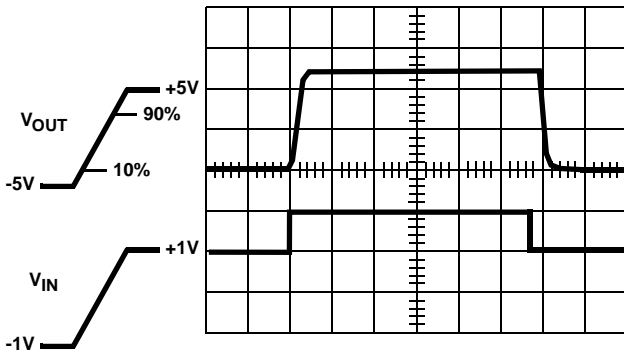

Vertical Scale: $V_{IN} = 2.0V/Div.$, $V_{OUT} = 4.0/Div.$
Horizontal Scale: 100ns/Div.

LARGE SIGNAL RESPONSE

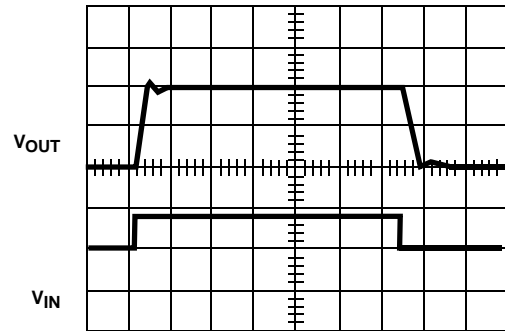

Vertical Scale: $V_{IN} = 50mV/Div.$, $V_{OUT} = 100mV/Div.$
Horizontal Scale: 100ns/Div

SMALL SIGNAL RESPONSE

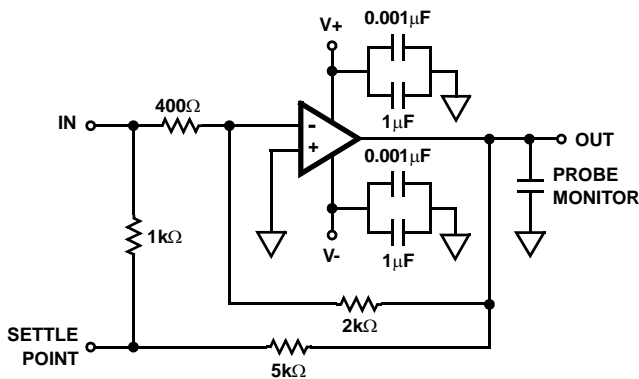

NOTES:

8. $A_V = -5$.
9. Load Capacitance should be less than 10pF.
10. It is recommended that resistors be carbon composition and that feedback and summing network ratios be matched to 0.1%.
11. Settle Point (Summing Node) capacitance should be less than 10pF. For optimum settling time results, it is recommended that the test circuit be constructed directly onto the device pins. A Tektronix 568 Sampling Oscilloscope with S-3A sampling heads is recommended as a settle point monitor.

FIGURE 2. SETTLING TIME TEST CIRCUIT

Schematic Diagram

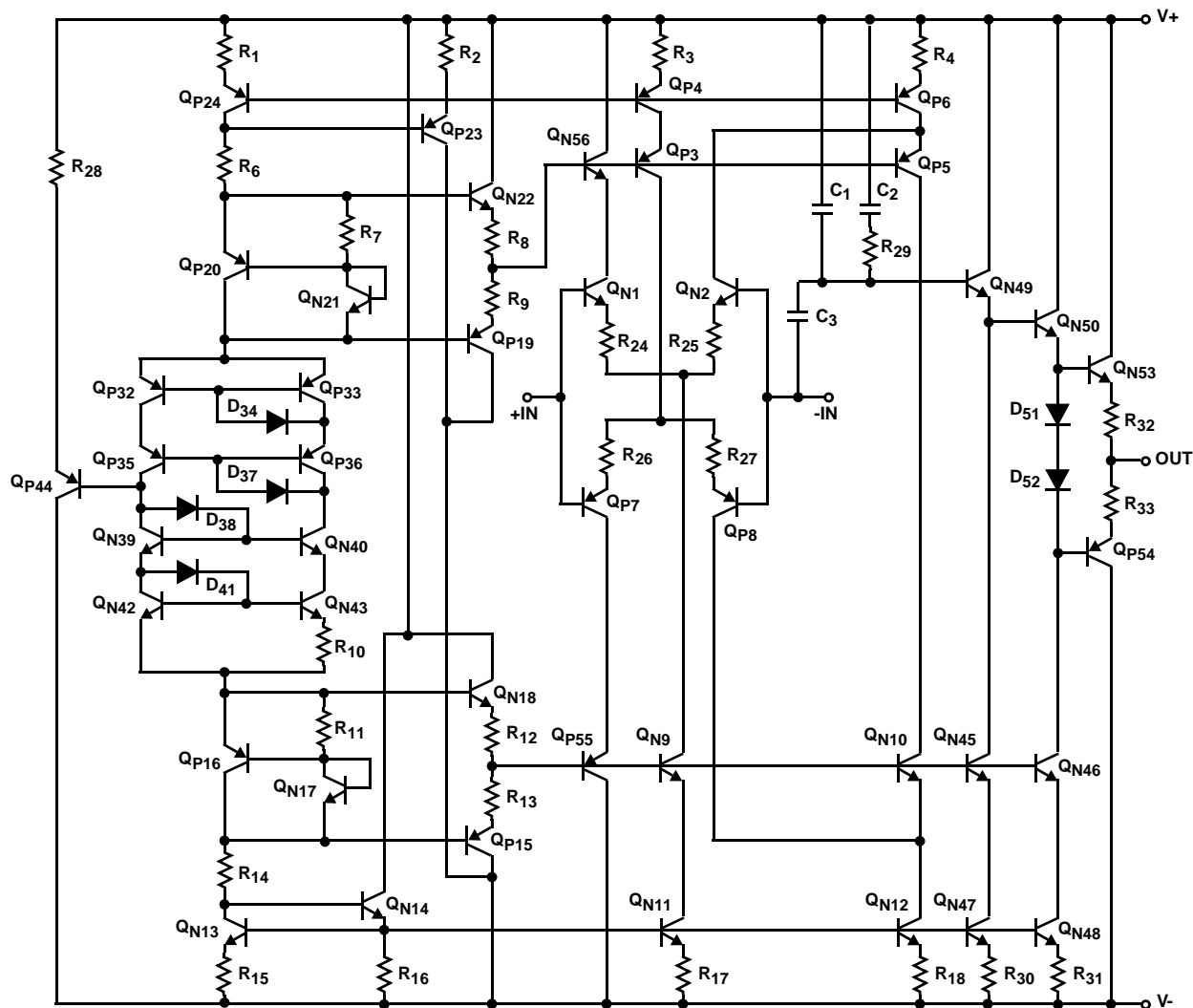

Application Information

Power Supply Decoupling

Although not absolutely necessary, it is recommended that all power supply lines be decoupled with 0.01 μ F ceramic capacitors to ground. Decoupling capacitors should be located as near to the amplifier terminals as possible.

Stability Considerations

HA-5195 is stable at gains > 5. Gains < 5 are covered below. Feedback resistors should be of carbon composition located as near to the input terminals as possible.

Wiring Considerations

Video pulse circuits should be built on a ground plane. Minimum point to point connections directly to the amplifier terminals should be used. When ground planes cannot be used, good single point grounding techniques should be applied.

Output Short Circuit

HA-5195 does not have output short circuit protection. Short circuits to ground can be tolerated for approximately 10 seconds. Short circuits to either supply will result in immediate destruction of the device.

Heavy Capacitive Loads

When driving heavy capacitive loads (>100pF) a small resistor (100 Ω) should be connected in series with the output and inside the feedback loop.

Typical Applications (Also see Application Notes AN525 and AN526)

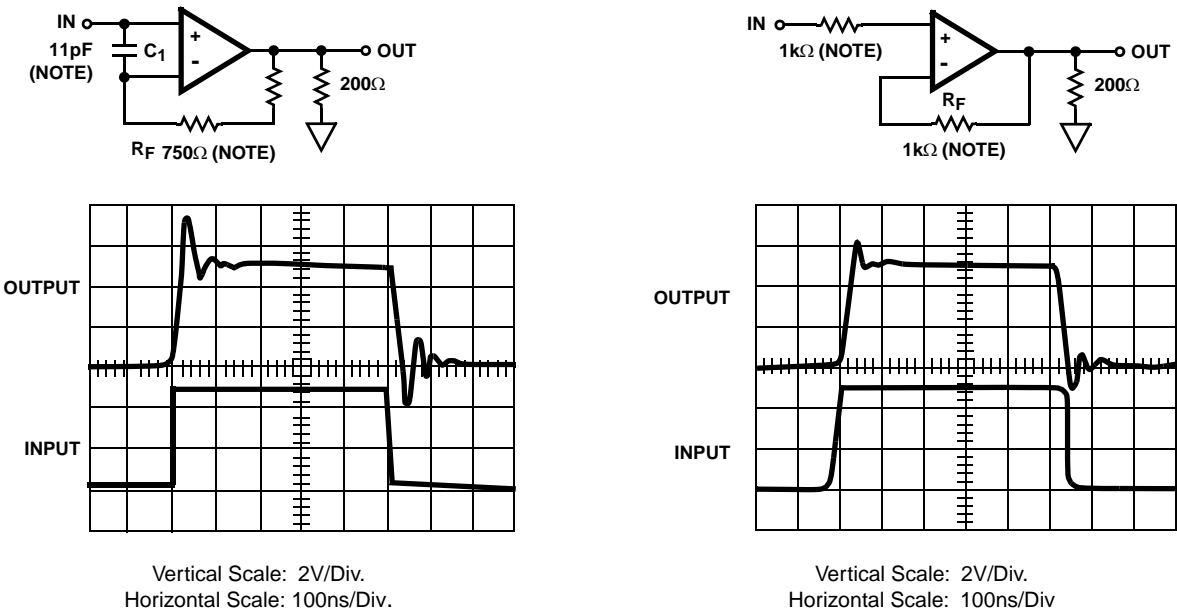

NOTE: Values were determined experimentally for optimum speed and settling time. R_F and C_1 should be optimized for each particular application to ensure best overall frequency response.

FIGURE 3. SUGGESTED COMPENSATION FOR NONINVERTING UNITY GAIN AMPLIFIER

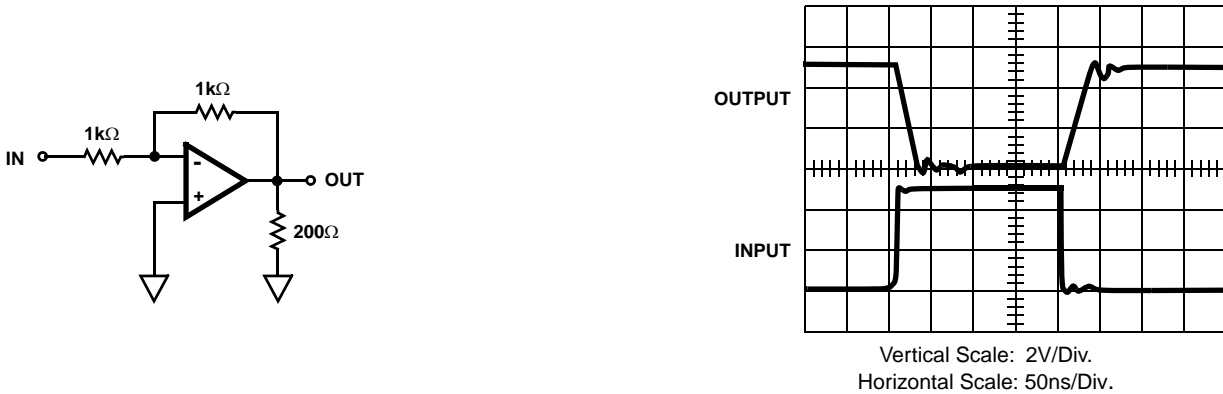

FIGURE 4. SUGGESTED COMPENSATION FOR INVERTING UNITY GAIN AMPLIFIER

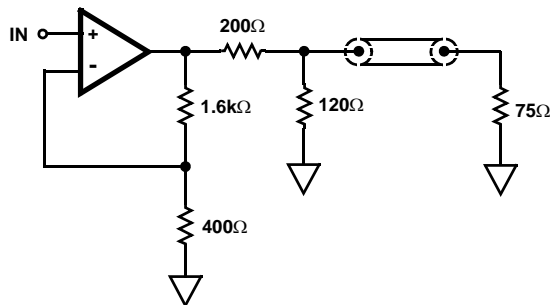

FIGURE 5. VIDEO PULSE AMPLIFIER/75Ω COAXIAL DRIVER

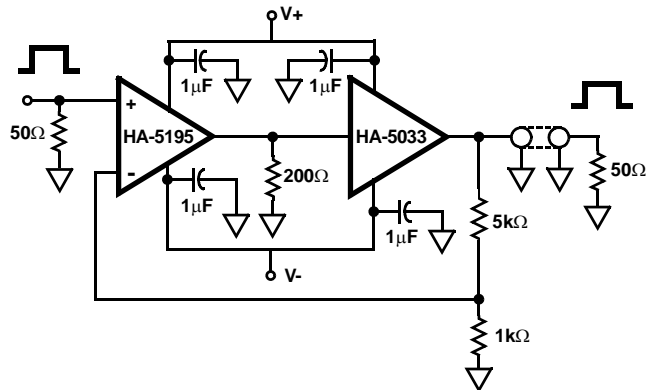

FIGURE 6. VIDEO PULSE AMPLIFIER COAXIAL LINE DRIVER

Typical Performance Curves $V_S = \pm 15V$, $T_A = 25^\circ C$, Unless Otherwise Specified

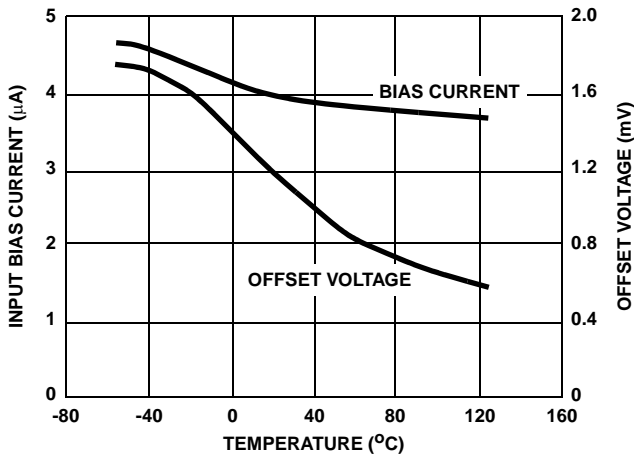

FIGURE 7. INPUT OFFSET VOLTAGE AND BIAS CURRENT vs TEMPERATURE

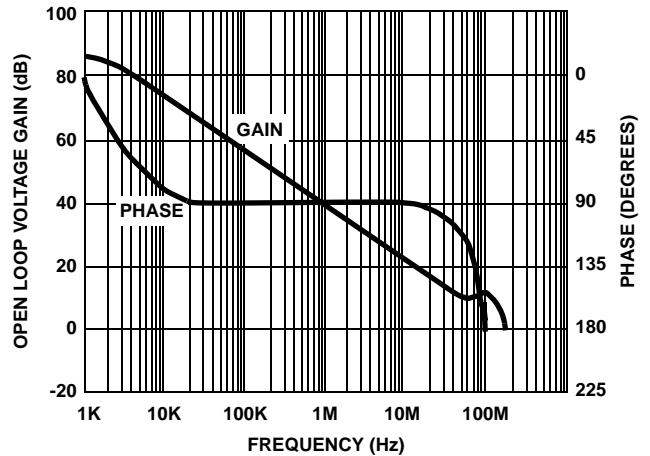

FIGURE 8. OPEN LOOP FREQUENCY RESPONSE

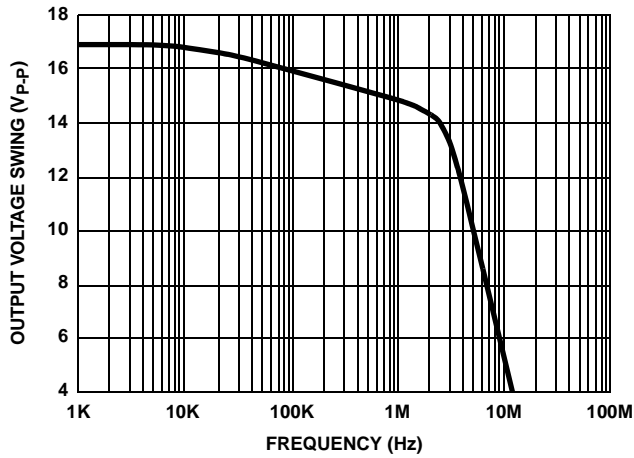

FIGURE 9. OUTPUT VOLTAGE SWING vs FREQUENCY

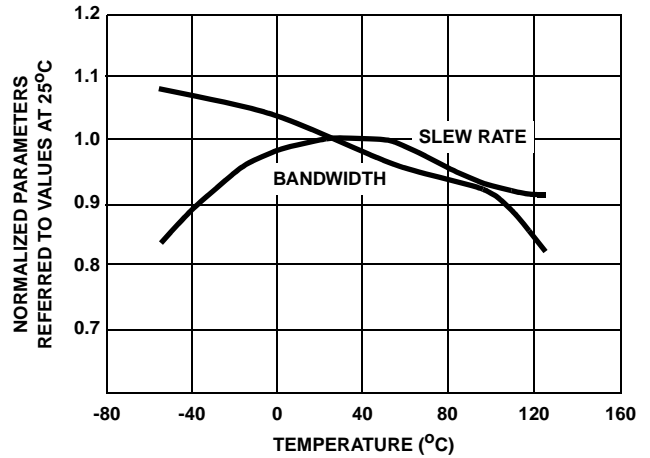

FIGURE 10. NORMALIZED AC PARAMETERS vs TEMPERATURE

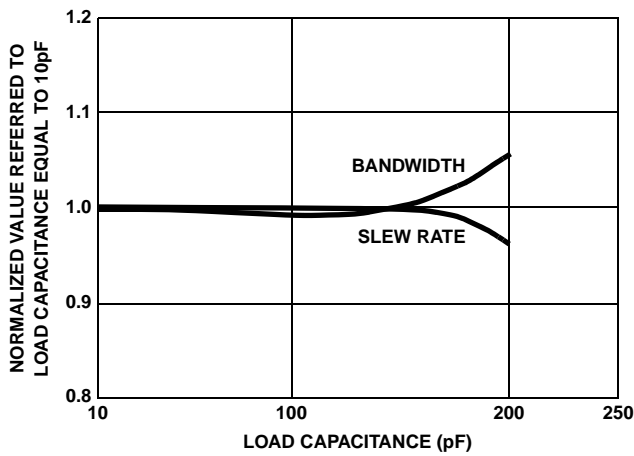

FIGURE 11. NORMALIZED AC PARAMETERS vs LOAD CAPACITANCE

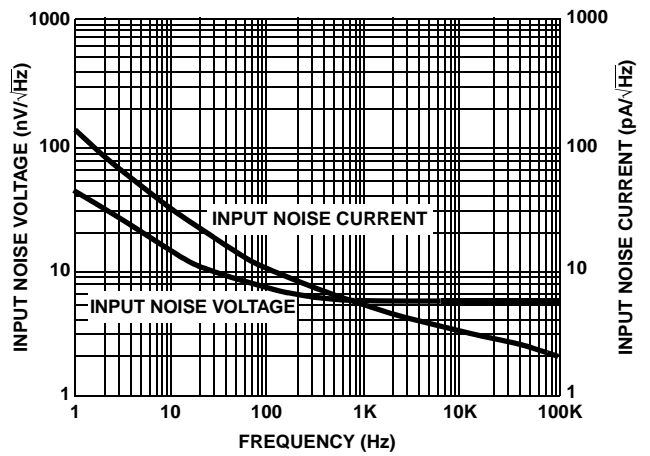

FIGURE 12. INPUT NOISE VOLTAGE AND NOISE CURRENT vs FREQUENCY

Typical Performance Curves $V_S = \pm 15V$, $T_A = 25^\circ C$, Unless Otherwise Specified (Continued)

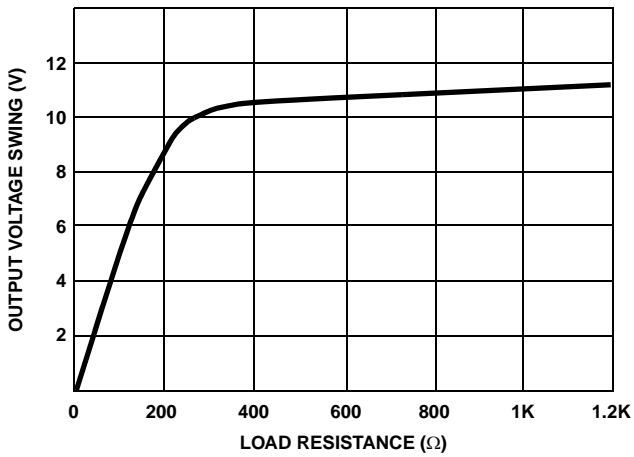

FIGURE 13. OUTPUT VOLTAGE SWING vs LOAD RESISTANCE

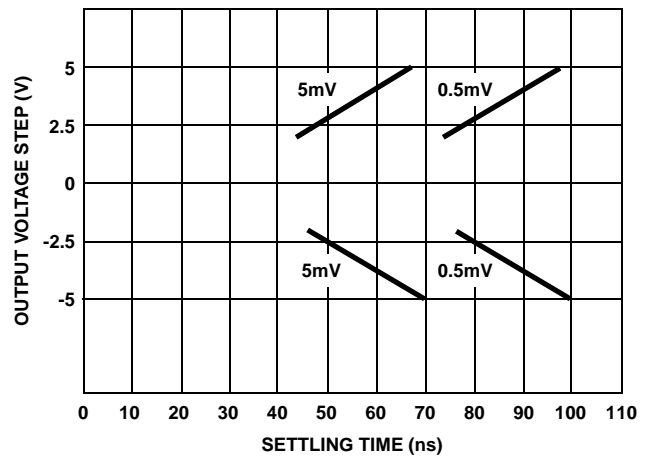

FIGURE 14. SETTLING TIME FOR VARIOUS OUTPUT STEP VOLTAGES

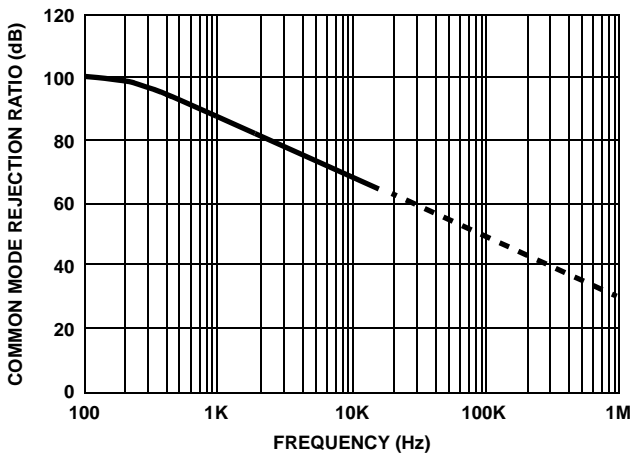

FIGURE 15. COMMON MODE REJECTION RATIO vs FREQUENCY

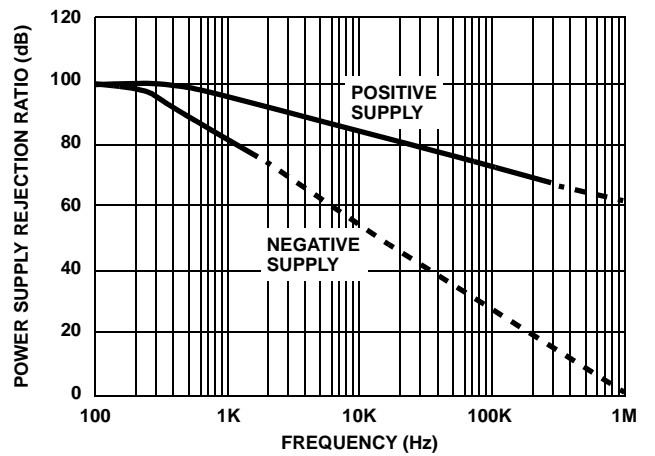

FIGURE 16. POWER SUPPLY REJECTION RATIO vs FREQUENCY

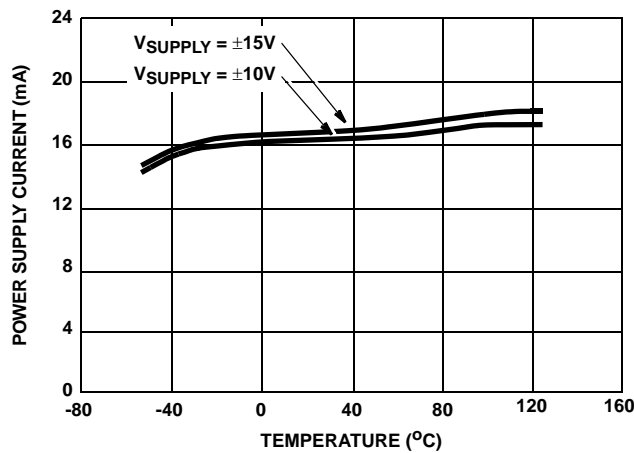

FIGURE 17. POWER SUPPLY CURRENT vs TEMPERATURE

Die Characteristics

DIE DIMENSIONS:

54 mils x 88 mils x 19 mils
 1360 μ m x 2240 μ m x 483 μ m

METALLIZATION:

Type: Al, 1% Cu
 Thickness: 16k \AA \pm 2k \AA

PASSIVATION:

Type: Nitride (Si₃N₄) over Silox (SiO₂, 5% Phos.)
 Silox Thickness: 12k \AA \pm 2k \AA
 Nitride Thickness: 3.5k \AA \pm 1.5k \AA

SUBSTRATE POTENTIAL (Powered Up):

V-

TRANSISTOR COUNT:

49

PROCESS:

Bipolar Dielectric Isolation

Metallization Mask Layout

HA-5195

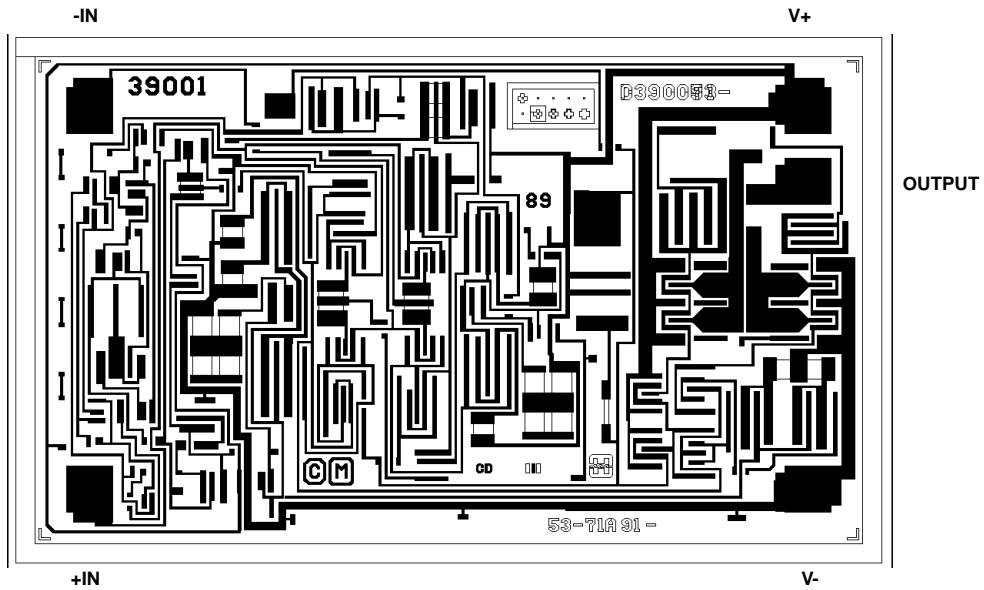

Ceramic Dual-In-Line Frit Seal Packages (CERDIP)

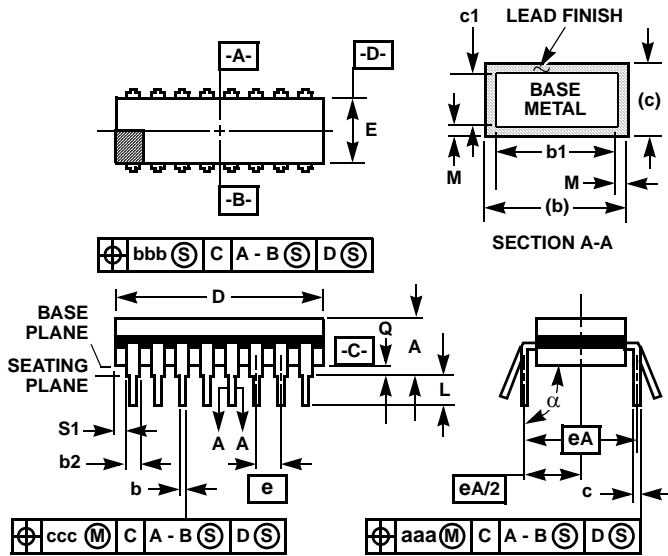

**F14.3 MIL-STD-1835 GDIP1-T14 (D-1, CONFIGURATION A)
14 LEAD CERAMIC DUAL-IN-LINE FRIT SEAL PACKAGE**

SYMBOL	INCHES		MILLIMETERS		NOTES
	MIN	MAX	MIN	MAX	
A	-	0.200	-	5.08	-
b	0.014	0.026	0.36	0.66	2
b1	0.014	0.023	0.36	0.58	3
b2	0.045	0.065	1.14	1.65	-
b3	0.023	0.045	0.58	1.14	4
c	0.008	0.018	0.20	0.46	2
c1	0.008	0.015	0.20	0.38	3
D	-	0.785	-	19.94	5
E	0.220	0.310	5.59	7.87	5
e	0.100 BSC		2.54 BSC		-
eA	0.300 BSC		7.62 BSC		-
eA/2	0.150 BSC		3.81 BSC		-
L	0.125	0.200	3.18	5.08	-
Q	0.015	0.060	0.38	1.52	6
S1	0.005	-	0.13	-	7
α	90°	105°	90°	105°	-
aaa	-	0.015	-	0.38	-
bbb	-	0.030	-	0.76	-
ccc	-	0.010	-	0.25	-
M	-	0.0015	-	0.038	2, 3
N	14		14		8

NOTES:

1. Index area: A notch or a pin one identification mark shall be located adjacent to pin one and shall be located within the shaded area shown. The manufacturer's identification shall not be used as a pin one identification mark.
2. The maximum limits of lead dimensions b and c or M shall be measured at the centroid of the finished lead surfaces, when solder dip or tin plate lead finish is applied.
3. Dimensions b1 and c1 apply to lead base metal only. Dimension M applies to lead plating and finish thickness.
4. Corner leads (1, N, N/2, and N/2+1) may be configured with a partial lead paddle. For this configuration dimension b3 replaces dimension b2.
5. This dimension allows for off-center lid, meniscus, and glass overrun.
6. Dimension Q shall be measured from the seating plane to the base plane.
7. Measure dimension S1 at all four corners.
8. N is the maximum number of terminal positions.
9. Dimensioning and tolerancing per ANSI Y14.5M - 1982.
10. Controlling dimension: INCH.

Rev. 0 4/94

All Intersil U.S. products are manufactured, assembled and tested utilizing ISO9000 quality systems. Intersil Corporation's quality certifications can be viewed at www.intersil.com/design/quality

Intersil products are sold by description only. Intersil Corporation reserves the right to make changes in circuit design, software and/or specifications at any time without notice. Accordingly, the reader is cautioned to verify that data sheets are current before placing orders. Information furnished by Intersil is believed to be accurate and reliable. However, no responsibility is assumed by Intersil or its subsidiaries for its use; nor for any infringements of patents or other rights of third parties which may result from its use. No license is granted by implication or otherwise under any patent or patent rights of Intersil or its subsidiaries.

For information regarding Intersil Corporation and its products, see www.intersil.com