

MAS9560

This is preliminary information on a new product under development. Micro Analog Systems Oy reserves the right to make any changes without notice.

Preliminary

Stereo Audio Driver DAC

- 16-Bit Stereo Audio DAC
- Stereo Headphone Drivers
- Mono Earpiece Driver
- Mono Loudspeaker Driver
- Mixing of Analog and Digital Audio Signals
- Integrated LDO
- Flexible Power Down Control

DESCRIPTION

The MAS9560 Stereo Audio DAC chip is specially intended to audio applications in portable devices. It has both analog and digital inputs for audio data thus enabling the mixing of signals. MAS9560 is equipped with integrated high performance LDO, which ensures high quality of output signal even in noisy power supply environment. MAS9560 has three

audio outputs (for headphone, earpiece and loudspeaker) making it an ideal choice for space critical applications. Since current consumption is a critical factor in portable devices, MAS9560 has flexible power down control enabling the shutting down of the parts of the circuit that are not in use.

FEATURES

- 16-Bit Stereo Audio DAC
- Stereo Headphone Drivers (25 mW)
- Mono Earpiece Driver (100 mW)
- Mono Loudspeaker Driver (410 mW)
- -50 dB to 32 dB Analog Volume Control
- Mute for All Volume Controls
- Analog and Digital Signal Mixing
- Integrated LDO
- Flexible Power Down Control
- Audio Sample Rates from 8 kHz to 48 kHz
- I²C/SPI Compatible Serial Control Port
- I²S Digital Audio Interface
- Supply Voltage Range 2.7 V to 5.5 V
- Digital I/O Voltage Range 1.8 V to 5.5 V
- Package QFN 6x6 40ld
- Compatible with DAC3560C

APPLICATIONS

- Portable devices with sophisticated audio functions:
 - Cell Phones
 - PDAs
 - MP3 players with integrated AM/FM radio

BLOCK DIAGRAM

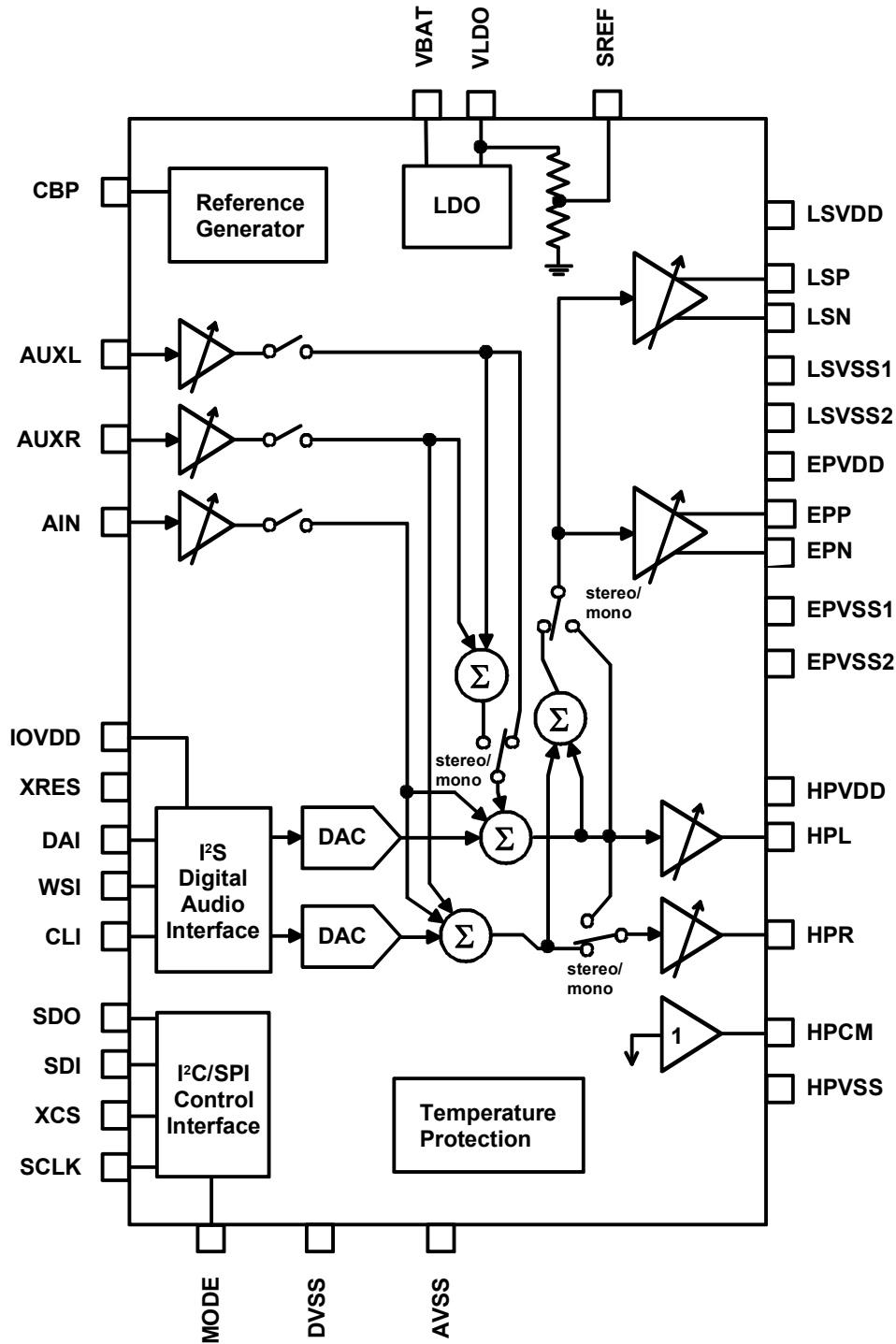

Figure 1. Block diagram of MAS9560

DETAILED BLOCK DESCRIPTION

◆ DAC

MAS9560 contains two digital-to-analog converters (DACs), which values are set through I²S bus (see I²S section for further description). The sampling rate of DACs is defined by WSI or CLI. In over sampling mode the sampling frequency is the frequency of CLI pin divided by four ($f_{CLI}/4$). WSI is used as a sampling clock in default mode.

◆ Audio Drivers

MAS9560 contains three audio drivers, all of which can be used simultaneously or separately. One driver is for loudspeaker, one for earpiece and one for headphone. The two latter ones have analog volume control from -30 dB gain to +6 dB gain in 1.5 dB steps, whereas the control range for loudspeaker driver is from -30 dB to +12 dB in 1.5 dB steps (see Control Register section p.18) The main features of each driver is as follows:

- Loudspeaker Driver: mono, differential output, output power: 410 mW @ $V_{DD} = 2.7$ V, 1100 mW @ $V_{DD} = 5.0$ V
- Earpiece Driver: mono, differential output, output power: 100 mW @ $V_{DD} = 2.7$ V, 300 mW @ $V_{DD} = 5.0$ V
- Headphone Driver: stereo, single-ended output, output power: 25 mW @ $V_{DD} = 2.7$ V, 80 mW @ $V_{DD} = 5.0$ V

All the drivers are short-circuit protected.

◆ Digital Audio Interface

Inter-IC Sound (I²S) bus is a 3-wire serial interface for transmission of 2-channel (stereo) Pulse Code Modulation digital data between MAS9560 and external digital audio source, for example MP3 player.

◆ LDO Voltage Regulator

MAS9560 has integrated low dropout voltage regulator, which output voltage is fixed 2.86 V. In power supply noisy environments the usage of this LDO in powering headphone and earpiece drivers improves the PSRR of these drivers to 100 dB and over. 10 nF bypass capacitor can be connected to CBP pin further improving the performance. In case LDO is not used (non-LDO mode) its output pin (VLDO) must be connected to external voltage source since it is supplying power for analog front-end.

The integrated LDO can also be disabled by using Mode-Control-Register.

◆ Reference Block

The reference block, which provides reference level for analog audio signals, has two modes:

- LDO mode: Audio reference level = VLDO/2. (SREF pin). This is half of integrated voltage regulator's output voltage.
- Non-LDO mode: Audio reference level = VLDO/2. VLDO should be connected to VBAT in Non-LDO mode.

◆ I²C/SPI Control Interface

MAS9560 has many user selectable options. These selections are mainly made by using registers, which are programmed via one of the two standard control interface protocols: I²C or SPI. The used control interface type is selected with MODE pin.

◆ Registers

MAS9560 has 11 on-chip registers, which byte length is 8 bits. Reset register is write-only, all other registers permit read and write access.

◆ Power Management

MAS9560 has Block Control Register, which allows separate blocks to be turned on and off independently. This can be used to reduce power consumption, since typically all the blocks are not needed at the same time. If, for example, only loudspeaker is used as an output, the drivers for earpiece and headphone can be disabled.

Additionally MAS9560 has Mode Control Register, which can be used to select operating mode for MAS9560. These four modes are as follows:

- Zero Power, where all digital and analog blocks are in power down mode. This is a default mode after startup.
- Analog stand-by, which is intended to be used as a wait state when starting the device. The purpose of this operating mode is to suppress audible plops caused by abrupt amplification changes when blocks in audio chain are waking up.
- Aux to Line, where DACs are disabled and only analog signaling is used.
- Full Power, where all blocks are active.

◆ Temperature Protection

MAS9560 is equipped with over temperature protection.

PIN CONFIGURATION

QFN 6x6 40ld

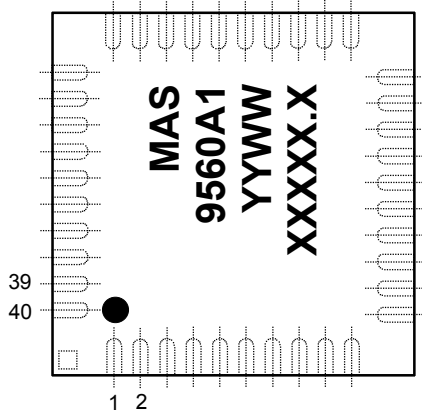

TOP VIEW

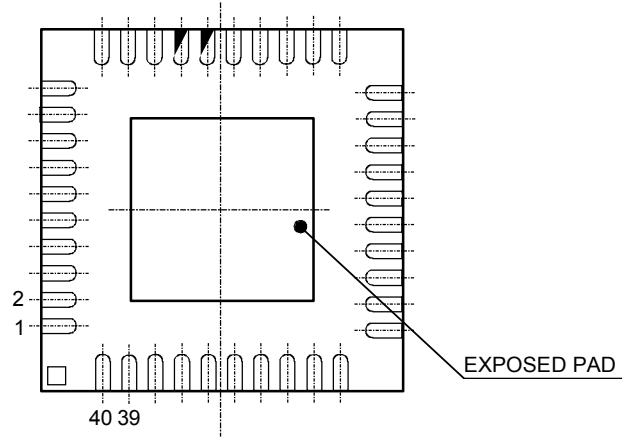

BOTTOM VIEW

Top Marking Information:
YYWW = Year, Week
XXXXX.X = Lot Number

PIN DESCRIPTION

G = Ground, I = Input, O = Output, P = Power

Pin Name	Pin Number	Type	Function
VBAT	1	P	Power Supply Voltage
LSVSS1	2	G	GND for Loudspeaker Driver
LSP	3	O	Loudspeaker Differential Output (Positive)
LSVDD	4	P	Power Supply Voltage for Loudspeaker Driver
LSN	5	O	Loudspeaker Differential Output (Negative)
LSVSS2	6	G	GND for Loudspeaker Driver
N/C	7	-	Not Connected
DVSS	8	G	Digital GND
MODE	9	I	Control Interface (I ² C / SPI) Selection
IOVDD	10	P	Digital I/O Power Supply Voltage
SDI	11	I/O	SPI Data In or I ² C Data In/Out
SCLK	12	I	SPI or I ² C Clock Signal
SDO	13	O	SPI Data Out
XCS	14	I	SPI Chip Select
DAI	15	I	I ² S Data In
WSI	16	I	I ² S Word Strobe Input
CLI	17	I	I ² S Clock Signal
XRES	18	I	Reset Input
N/C	19	-	Not Connected
N/C	20	-	Not Connected
AIN	21	I	Analog Input (Mono)

Pin Name	Pin Number	Type	Function
AUXL	22	I	Analog Auxiliary (AUX) Input Left Channel (Stereo)
AUXR	23	I	Analog Auxiliary (AUX) Input Right Channel (Stereo)
HPCM	24	O	Headphone Common Output
HPVSS	25	G	GND for Headphone Driver
HPL	26	O	Headphone Output (Left Channel)
HPR	27	O	Headphone Output (Right Channel)
HPVDD	28	P	Power Supply Voltage for Headphone Driver
N/C	29	-	Not Connected
SREF	30	O	Audio Signal Reference Level
CBP	31	I	Pin for LDO Bypass Capacitor
EPVSS2	32	G	Earpiece Ground
EPN	33	O	Earpiece Differential Output (Negative)
EPVDD	34	P	Power Supply for Earpiece Driver
EPP	35	O	Earpiece Differential Output (Positive)
EPVSS1	36	G	GND for Earpiece Driver
AVSS	37	G	Analog Ground
N/C	38	-	Not Connected
N/C	39	-	Not Connected
VLDO (AVDD)	40	P	LDO Output (Analog Power Supply)
Exposed Pad			Exposed pad should be soldered to GND layer to improve heat dissipation

Note: Pins EPVDD and HPVDD have to be connected to VLDO pin.

DETAILED PIN DESCRIPTIONS

◆ Power supply pins

The power supply of MAS9560 is divided into functional sections so that:

- DVSS is connected internally with all digital parts
- IOVDD and DVSS are connected internally with all digital inputs and outputs
- DVSS is ground connection for all digital parts
- All GND pins are internally connected together
- LSVDD and VBAT are internally connected together

Other power supply pins should be connected as follows:

- VLDO should be connected to VBAT in non-LDO mode. If LDO mode is selected, VLDO is the output of LDO.
- HPVDD and EPVDD can be driven by VLDO in LDO mode to reduce power supply noise
- HPVSS, EPVSS, LSVSS must be connected to analog ground (AVSS). The pins are internally connected together.

ABSOLUTE MAXIMUM RATINGS

All voltages with respect to ground.

Parameter	Symbol	Pin Name	Min	Max	Unit
Supply Voltage (VBAT and LSVDD are internally connected together)	V _{BAT}	VBAT, LSVDD	-0.3	6	V
Voltage Range for Other Pins			-0.3	VBAT + 0.3	V
ESD Rating (HBM)				2	kV
Junction Temperature	T _{Jmax}			+175 (limited)	°C
Storage Temperature	T _S		-55	+150	°C
Power Dissipation (T _A = +85°C) (Exposed pad soldered to PCB)				1.2	W

Stresses beyond those listed may cause permanent damage to the device. The device may not operate under these conditions, but it will not be destroyed.

RECOMMENDED OPERATING CONDITIONS

All voltages with respect to ground.

Parameter	Symbol	Pin Name	Conditions	Min	Nom	Max	Unit
Operating Junction Temperature	T _J			-40		+125	°C
Operating Ambient Temperature	T _A			-40		+85	°C
Master Supply Voltage		VBAT, LSVDD	LDO mode, VBAT and LSVDD internally connected	3.0	3.6	5.5	V
Master Supply Voltage		VBAT, LSVDD, VLDO, EPVDD, HPVDD	Non-LDO mode, VBAT and LSVDD internally connected	2.7	3.6	5.5	V
Analog Operating Supply Voltage	V _{BAT}	VBAT, LSVDD	Internally connected together	2.7		5.5	
		VLDO, HPVDD, EPVDD		2.7		V _{BAT}	V
Digital Interface Voltage	IO_V _{DD}	IOVDD		1.5		V _{BAT}	V
Earpiece Supply Voltage		EPVDD		2.7		V _{BAT}	V
Headphone Supply Voltage		HPVDD		2.7		V _{BAT}	V

RECOMMENDED EXTERNAL COMPONENTS

Parameter	Symbol	Pin Name	Min	Typ	Max	Unit	Note
LDO Output Capacitance	C_{L_LDO}	VLDO	0.23		C_{IN_LDO}	μF	<ol style="list-style-type: none"> 1. Ceramic and film capacitors can be used. 2. The value of C_{L_LDO} should be smaller than or equal to the value of C_{IN_LDO}.
Effective Series Resistance	ESR		0.01		3	Ohm	<ol style="list-style-type: none"> 1. When within this range, stable with all $I_{OUT} = 0\text{ mA} \dots 150\text{ mA}$ values.
LDO Bypass Capacitance (Optional: if C_{BYPASS} is not used, noise performance and PSRR decline, but rise time is improved.)	C_{BP_LDO}	CBP		0.01		μF	<ol style="list-style-type: none"> 1. Ceramic and film capacitors are best suited. For maximum output voltage accuracy DC leakage current through capacitor should be kept as low as possible. In any case DC leakage current must be below 100 nA.
LDO Input Capacitance	C_{IN_LDO}	VBAT	0.5			μF	<ol style="list-style-type: none"> 1. A big enough input capacitance is needed to prevent possible impedance interactions between the supply and LDO. 2. Ceramic, tantalum, and film capacitors can be used. If a tantalum capacitor is used, it should be checked that the surge current rating is sufficient for the application. 3. In the case that the inductance between a battery and LDO is very small ($< 0.1\ \mu H$), a $0.47\ \mu F$ input capacitor is sufficient. 4. The value of C_{IN_LDO} should not be smaller than the value of C_{L_LDO}.
When selecting capacitors, tolerance and temperature coefficient must be considered to make sure that the capacitance and resistance are between the above specified limits in all potential operating conditions.							
Analog Input Coupling Capacitor	$C_{AIN}, C_{AUXL}, C_{AUXR}$	AUXL, AUXR, AIN		470		nF	<ol style="list-style-type: none"> 1. Affects on input signal's pass band frequency.
SREF Bypass Capacitor	C_{SREF}	SREF		3.3		μF	<ol style="list-style-type: none"> 1. A too small value capacitor cannot effectively prevent disturbance from getting to signal ground.
Load Resistance: Headphone	R_{L_HP}	HPR, HPL, HPCM	16	32		ohm	
Load Resistance: Earpiece	R_{L_EP}	EPP, EPN	16	32		ohm	
Load Resistance: Loudspeaker	R_{L_S}	LSP, LSN	4	8		ohm	

ELECTRICAL CHARACTERISTICS IN LDO MODE
◆ Integrated LDO Characteristics

LSVDD = VBAT = 3.6V, EPVDD = HPVDD = VLDO = 2.86V (LDO-mode), $-40^{\circ}\text{C} \leq T_A \leq +85^{\circ}\text{C}$, , typical values at $T_A = +27^{\circ}\text{C}$,
 $I_{\text{OUT}} = 1.0 \text{ mA}$, $C_{\text{IN_LDO}} = 1.0 \mu\text{F}$, $C_{\text{L_LDO}} = 1.0 \mu\text{F}$, $C_{\text{BP_LDO}} = 10 \text{ nF}$, unless otherwise noted

Parameter	Pin Name	Conditions	Min	Nom	Max	Unit
Output Voltage	VLDO	Operational Mode	2.75	2.86	2.95	V
		Standby Mode, LDO not bypassed		2.86		
		Standby Mode, LDO bypassed		V_{BAT}		
		Zero Power Mode, LDO not bypassed		0		
		Zero Power Mode, LDO bypassed		V_{BAT}		
Dropout Voltage	VLDO	$I_{\text{OUT}} = 1 \text{ mA}$ $I_{\text{OUT}} = 50 \text{ mA}$ $I_{\text{OUT}} = 150 \text{ mA}$		1.7 70 200		mV
Continuous Output Current	VLDO		0		150	mA
Short Circuit Current	VLDO	$R_L = 0 \Omega$	200	450	675	mA
Peak Output Current	VLDO	$V_{\text{OUT}} > 95\% * V_{\text{OUT(NOM)}}$		410		mA
Line Regulation	VLDO	$3.6 \text{ V} < V_{\text{BAT}} < 5.3 \text{ V}$, $I_{\text{OUT}} = 60 \text{ mA}$		0.7		mV
Load Regulation	VLDO	$I_{\text{OUT}} = 1 \text{ mA to } 50 \text{ mA}$ $I_{\text{OUT}} = 1 \text{ mA to } 150 \text{ mA}$		5		mV
				10		
Output Noise Voltage	VLDO	$300 \text{ Hz} < f < 50 \text{ kHz}$ $C_{\text{BP_LDO}} = 10 \text{ nF}$ w/o $C_{\text{BP_LDO}}$		20 110		μVrms
Noise Density	VLDO	$I_{\text{OUT}} = 50 \text{ mA}$, $f = 1 \text{ kHz}$		100		$\text{nV}/\sqrt{\text{Hz}}$
PSRR	VLDO	$f = 1 \text{ kHz}$ $f = 10 \text{ kHz}$ $f = 100 \text{ kHz}$		67		dB
				65		
				48		
Rise Time (10%... 90%)	VLDO	$I_{\text{OUT}} = 30\text{mA}$ $C_{\text{BP_LDO}} = 10 \text{ nF}$ w/o $C_{\text{BP_LDO}}$		4 16		ms μs
Overshoot	VLDO	w/o $C_{\text{BP_LDO}}$		3	10	%
Start-up Delay (From the time LDO is enabled via register until VLDO is 90% of the nominal V_{OUT})	VLDO	w/o $C_{\text{BP_LDO}}$		17		μs
Thermal Protection/ Threshold High			145	160	175	$^{\circ}\text{C}$
Thermal Protection/ Threshold Low			135	150	165	$^{\circ}\text{C}$

The hysteresis of 10°C prevents the device from turning on too soon after thermal shut-down.

◆ Analog Audio Inputs (AIN, AUXL, AUXR) in LDO mode

 LSVDD = VBAT = 3.6V, EPVDD = HPVDD = VLDO = 2.86 V (LDO-mode), $-40^{\circ}\text{C} \leq T_A \leq +85^{\circ}\text{C}$, typical values at $T_A = +27^{\circ}\text{C}$, unless otherwise noted

Parameter	Pin Name	Min	Nom	Max	Unit
Input Range	AIN, AUXL, AUXR		2.05		V _{PP}
Input Clipping Level	AIN, AUXL, AUXR			VLDO	V
Input Resistance	AIN, AUXL, AUXR	Gain = -20 dB	23		k Ω
		Gain = 0 dB	14		
		Gain = +20 dB	3		
Gain Setting Range	AIN, AUXL, AUXR	-20		20	dB
Gain Step Size	AIN, AUXL, AUXR	1.5	2	2.5	dB
Absolute Gain Error	AIN, AUXL, AUXR	-1.2	0	1.2	dB

◆ Analog Audio Outputs (Headphone, Earpiece, Loudspeaker) in LDO mode

 LSVDD = VBAT = 3.6V, EPVDD = HPVDD = VLDO = 2.86 V (LDO-mode), $-40^{\circ}\text{C} \leq T_A \leq +85^{\circ}\text{C}$, typical values at $T_A = +27^{\circ}\text{C}$, unless otherwise noted

Parameter	Pin Name	Conditions	Min	Nom	Max	Unit
Volume Range (Headphone and Earpiece)	HPL,HPR ,EPP,EP N		-30		6	dB
Volume Range (Loudspeaker)	LSP,LSN		-30		12	dB
Volume Control Step Size	HPL,HPR ,EPP,EP N,LSP,LS N		1.0	1.5	2.0	dB
Headphone Output Power	HPL, HPR, (HPCM)	THD < 0.1%, f = 1 kHz, R _L = 32 Ω		25 (25)		mW
Earpiece Output Power	EPP, EPN	THD < 0.2%, f = 1 kHz, R _L = 32 Ω		100		mW
Loudspeaker Output Power	LSP, LSN	THD < 1%, f = 1 kHz, R _L = 8 Ω		410		mW
Headphone Short Circuit Current	HPL, HPR, HPCM, VLDO, AVSS		250	350	450	mA
Earpiece Short Circuit Current	EPP, EPN, VLDO, AVSS		250	350	450	mA
Loudspeaker Short Circuit Current	LSP, LSN		800	1000		mA
Headphone and Earpiece Output Signal Reference Level	HPL, HPR, HPCM, EPP, EPN	SREF settled		VLDO/2		V
Loudspeaker Output Signal Reference Level	LSP, LSN	SREF settled		LSVDD/ 2		V

◆ Dynamic Performance in LDO mode

 LSVDD = VBAT = 3.6 V, EPVDD = HPVDD = VLDO = 2.86 V (LDO-mode), $-40^{\circ}\text{C} \leq T_A \leq +85^{\circ}\text{C}$, typical values at $T_A = +27^{\circ}\text{C}$, unless otherwise noted

Parameter	Pin Name	Conditions	Min	Nom	Max	Unit	
Headphone Full Scale Output Level	HPL, HPR, HPCM	No load, Volumes = 0 dB		2.04		Vpp	
Earpiece Full Scale Output Level	EPP, EPN	No load, Volumes = 0 dB		4.08		Vpp	
Loudspeaker Full Scale Output Level	LSP, LSN	No load, Volumes = 0 dB		4.08		Vpp	
Absolute 0 dB Gain, Analog In to Analog Out (unweighted), DAC off	AIN, AUXL, AUXR, HPL, HPR, HPCM, EPP, EPN, LSP, LSN	Analog to Headphone	-1.2	0	+1.2	dB	
		Analog to Earpiece	-1.2	0	+1.2		
		Analog to Loudspeaker	-1.2	0	+1.2		
Mute Level	AIN, AUXL, AUXR, HPL, HPR, HPCM, EPP, EPN, LSP, LSN	Headphone	-40	-75		dB	
		Earpiece	-40	-75			
		Loudspeaker	-40	-75			
		Analog Input (AIN)	-40	-60			
		Auxiliary Input (AUXL, AUXR)	-40	-65			
Dynamic Range, Digital In to Analog Out (unweighted)	HPL, HPR, (HPCM)	$f_{\text{SAMPLE}} = 48 \text{ kHz}$ with 16-bit data, Bandwidth = 20 Hz... 20 kHz	DAC to Headphone		81		dB
	EPP, EPN		DAC to Earpiece		76		
	LSP, LSN		DAC to Loudspeaker		76		
Dynamic Range, Digital In to Analog Out (A-weighted)	HPL, HPR, (HPCM)	$f_{\text{SAMPLE}} = 48 \text{ kHz}$ with 16-bit data, Bandwidth = 20 Hz... 20 kHz	DAC to Headphone		86		dB
	EPP, EPN		DAC to Earpiece		82		
	LSP, LSN		DAC to Loudspeaker		82		
Dynamic Range, Analog In to Analog Out (unweighted)	AIN, AUXL, AUXR, HPL, HPR, HPCM,	DAC off, Analog to Headphone		92		dB	
	AIN, AUXL, AUXR, EPP, EPN	DAC off, Analog to Earpiece		89			
	AIN, AUXL, AUXR, LSP, LSN	DAC off, Analog to Loudspeaker		82			

Dynamic Range, Analog In to Analog Out (A-weighted)	AIN, AUXL, AUXR, HPL, HPR, HPCM,	DAC off, Analog to Headphone		95		dB
	AIN, AUXL, AUXR, EPP, EPN	DAC off, Analog to Earpiece		86		dB
	AIN, AUXL, AUXR, LSP, LSN	DAC off, Analog to Loudspeaker		85		dB
Headphone THD + Noise	HPL, HPR, (HPCM)	f = 50 Hz... 20 kHz, $R_L = 32 \Omega$, Pout = 15 mW		-65 (-63)		dB
Earpiece THD + Noise	EPP, EPN	f = 150 Hz... 20 kHz, $R_L = 32 \Omega$, Pout = 50 mW		-55		dB
Loudspeaker THD + Noise	LSP, LSN	f = 150 Hz... 20 kHz, $R_L = 8 \Omega$, Pout = 200 mW		-58		dB
Mute Level	HPL, HPR, (HPCM), EPP, EPN, LSP, LSN			-73		dB
Headphone PSRR	HPL, HPR, HPCM, VBAT	f = 1.0 kHz, VBAT \geq 3.1 V, $R_L = 32 \Omega$, Vripple = 0.5 Vpp, Zero audio signal		120		dB
Earpiece PSRR	EPP, EPN, VBAT	f = 1.0 kHz, VBAT \geq 3.1 V, $R_L = 32 \Omega$, Vripple = 0.5 Vpp, Zero audio signal		120		dB
Loudspeaker PSRR	LSVDD, LSP, LSN	f = 1.0 kHz, LSVDD \geq 3.1 V, $R_L = 8 \Omega$, Vripple = 0.5 Vpp, Zero audio signal	40	63		dB

◆ **Current Consumption**

LSVDD = VBAT = 3.6V, EPVDD = HPVDD = VLDO = 2.86V (LDO-mode), $-40^{\circ}\text{C} \leq T_A \leq +85^{\circ}\text{C}$, , typical values at $T_A = +27^{\circ}\text{C}$, $I_{\text{OUT}} = 1.0 \text{ mA}$, $C_{\text{IN_LDO}} = 1.0 \mu\text{F}$, $C_{\text{L_LDO}} = 1.0 \mu\text{F}$, $C_{\text{BP_LDO}} = 10 \text{ nF}$, unless otherwise noted

Control Bits	VBAT	Current measurement test setup								
Mono				X	X	X	X			
DAC		X	X	X	X					X
AIN						X	X			X
AUX								X	X	X
LS				X		X				X
EP					X		X			X
HPR		X	X					X	X	X
HPL		X	X					X	X	X
HPC			X						X	X
Typical Current [mA]	3.00 V	3.1	5.4	8.4	4.6	9.0	4.9	5.8	7.1	19
	3.60 V	3.1	5.5	12	4.6	13	4.9	5.8	7.1	22
	5.50 V	3.1	5.3	37	4.6	37	4.9	5.8	7.1	47
Maximum Current [mA]	3.00 V	7.5	10	20	7	20	8	10	12	40
	3.60 V	7.5	10	25	7	25	8	10	12	40
	5.50 V	7.5	10	70	7	70	8	10	12	80

Note: Above values measured with following loads: loudspeaker LSP-LSN 22 ohm (nominal load 8 ohm cannot be used in testing due to tester limitations), earphone EPP-EPN 32 ohm, HPR-HPCM 32 ohm, HPL-HPCM 32 ohm.

ELECTRICAL CHARACTERISTICS IN NON-LDO MODE

◆ Analog Audio Inputs (AIN, AUXL, AUXR) in non-LDO mode

LSVDD = VBAT = EPVDD = HPVDD = VLDO = 2.7 V...5.5 V (non-LDO-mode), $-40^{\circ}\text{C} \leq T_A \leq +85^{\circ}\text{C}$, typical values at $T_A = +27^{\circ}\text{C}$, unless otherwise noted

Parameter	Pin Name	Conditions	Min	Nom	Max	Unit
Full Scale Input Level	AIN, AUXL, AUXR	Volumes = 0 dB		$0.715 \times \text{VLDO}$	VLDO	Vpp
Input Clipping Level	AIN, AUXL, AUXR				VLDO	V
Input Resistance	AIN, AUXL, AUXR	Gain = -20 dB		23		k Ω
		Gain = 0 dB		14		
		Gain = +20 dB		3		
Gain Setting Range	AIN, AUXL, AUXR		-20		20	dB
Gain Step Size	AIN, AUXL, AUXR		1.5	2	2.5	dB
Absolute Gain Error	AIN, AUXL, AUXR		-1.2	0	1.2	dB

◆ Analog Audio Outputs (Headphone, Earpiece, Loudspeaker) in non-LDO mode

LSVDD = VBAT = EPVDD = HPVDD = VLDO = 2.7 V...5.5 V (non-LDO-mode), $-40^{\circ}\text{C} \leq T_A \leq +85^{\circ}\text{C}$, typical values at $T_A = +27^{\circ}\text{C}$, unless otherwise noted

Parameter	Pin Name	Conditions	Min	Nom	Max	Unit
Headphone Output Power	HPL, HPR, HPCM	HPVDD = 5.5 V, THD < 0.1%, $f = 1 \text{ kHz}, R_L = 32 \Omega$		80		mW
Earpiece Output Power	EPP, EPN	EPVDD = 5.5 V, THD < 0.2%, $f = 1 \text{ kHz}, R_L = 32 \Omega$		300		mW
Loudspeaker Output Power	LSP, LSN	LSVDD = 5.5 V, THD < 1%, $f = 1 \text{ kHz}, R_L = 8 \Omega$		1100		mW
Headphone and Earpiece Output Signal Reference Level	EPP, EPN, HPL, HPR, HPCM	SREF settled		VLDO/2		V
Loudspeaker Output Signal Reference Level	LSP, LSN	SREF settled		VBAT/2		V

◆ Dynamic Performance in non-LDO mode

LSVDD = VBAT = EPVDD = HPVDD = VLDO = 3.6 V (non-LDO-mode), $-40^{\circ}\text{C} \leq T_A \leq +85^{\circ}\text{C}$, typical values at $T_A = +27^{\circ}\text{C}$, unless otherwise noted

Parameter	Pin Name	Conditions	Min	Nom	Max	Unit
Headphone Full Scale Output Level	HPL,	No load, Volumes = 0 dB			HPVDD	Vpp
	HPR					
Earpiece Full Scale Output Level	EPP,	No load, Volumes = 0 dB			EPVDD	Vpp
	EPN					
Loudspeaker Full Scale Output Level	LSP, LSN	No load, Volumes = 0 dB			LSVDD	Vpp

Dynamic Range, Digital In to Analog Out (unweighted)	HPL, HPR, (HPCM)	$f_{\text{SAMPLE}} =$ 48 kHz with 16-bit data, Bandwidth = 20 Hz... 20 kHz	DAC to Headphone	82		dB
	EPP, EPN		DAC to Earpiece	76		dB
	LSP, LSN		DAC to Loudspeaker	76		dB
Dynamic Range, Digital In to Analog Out (A-weighted)	HPL, HPR, (HPCM)	$f_{\text{SAMPLE}} =$ 48 kHz with 16-bit data, Bandwidth = 20 Hz... 20 kHz	DAC to Headphone	86		dB
	EPP, EPN		DAC to Earpiece	82		dB
	LSP, LSN		DAC to Loudspeaker	82		dB
Dynamic Range, Analog In to Analog Out (unweighted)	AIN, AUXL, AUXR, HPL, HPR, HPCM	DAC off , Analog to HP		84		dB
	AIN, AUXL, AUXR, EPP, EPN	DAC off, Analog to EP		92		dB
	AIN, AUXL, AUXR, LSP, LSN	DAC off, Analog to LS		92		dB
Dynamic Range, Analog In to Analog Out (A-weighted)	AIN, AUXL, AUXR, HPL, HPR, HPCM	DAC off, Analog to HP		86		dB
	AIN, AUXL, AUXR, EPP, EPN	DAC off, Analog to EP		96		dB
	AIN, AUXL, AUXR, LSP, LSN	DAC off, Analog to LS		96		dB
Headphone THD + Noise	HPL, HPR, (HPCM)	$f = 50 \text{ Hz} \dots 20 \text{ kHz},$ $R_L = 32 \Omega,$ $P_{\text{out}} = 15 \text{ mW}$	VBAT = 2.7 V	-62 (-61)		dB
			VBAT = 3.6 V	-66 (-66)		
			VBAT = 5.0 V	-68 (-68)		
Earpiece	EPP,	$f = 150 \text{ Hz} \dots 20 \text{ kHz},$	VBAT = 2.7 V	-54		dB

THD + Noise	EPN	$R_L = 32 \Omega$, Pout = 50 mW	VBAT = 3.6 V	-62	
			VBAT = 5.0 V	-68	
Loudspeaker THD + Noise	LSP, LSN	$f = 150 \text{ Hz} \dots 20 \text{ kHz}$, $R_L = 8 \Omega$, Pout = 200 mW	VBAT = 2.7 V	-56	mW
			VBAT = 3.6 V	-58	
			VBAT = 5.0 V	-62	
Mute Level	HPL, HPR, (HPCM) , EPP, EPN, LSP, LSN			-75	dB
Headphone PSRR	HPL, HPR, HPCM, VBAT	$f = 1.0 \text{ kHz}$, VBAT $\geq 3.1 \text{ V}$, $R_L = 32 \Omega$, Vripple = 0.5 Vpp, Zero audio signal		54	dB
Earpiece PSRR	EPP, EPN, VBAT	$f = 1.0 \text{ kHz}$, VBAT $\geq 3.1 \text{ V}$, $R_L = 32 \Omega$, Vripple = 0.5 Vpp, Zero audio signal		69	dB
Loudspeaker PSRR	LSVDD, LSP, LSN	$f = 1.0 \text{ kHz}$, LSVDD $\geq 3.1 \text{ V}$, $R_L = 8 \Omega$, Vripple = 0.5 Vpp, Zero audio signal	40	63	dB

◆ Definitions

Dynamic Range: Dynamic range means the difference between the highest and lowest levels of the signal. Due to the fact that the dynamic range of a loudspeaker (or similar) would significantly affect the dynamic range measurement of MAS9560, the following has been made: THD+N has been

measured at -60 dB, and dynamic range has been derived of that by adding 60 dB to that value. For example THD+N = -30 dB → Dynamic range = 90 dB.

THD+N: Total Harmonic Distortion + Noise

CONTROL INTERFACES

MAS9560 registers (detailed description below) are controlled either via I²C- or SPI bus. On-chip DAC data is written using I²S-bus.

Pin	Bus	Function
MODE	I ² C/SPI	Select I ² C (MODE=1) or SPI (MODE=0)
SCLK	I ² C /SPI	Serial Data Clock for I ² C and SPI
SDI	I ² C /SPI	Serial Data I/O for I ² C and input for SPI
SDO	SPI	Serial Data Output for SPI
XCS	SPI	Chip Select for SPI (active low)
DAI	I ² S	Serial Data input for I ² S
WSI	I ² S	Frame Identification for I ² S
CLI	I ² S	Serial Data Clock for I ² S

◆ I²C Description

I²C – bus is selected by setting pin MODE = 1. I²C - bus is a 2-wire serial interface, so two lines, a serial data line (SDI) and serial clock line (SCLK), are required. MAS9560 data line is bi-directional for data acknowledge and transmit, but clock line is just a receiver, i.e., the clock is gotten from the master. Default state for both lines is high, since all devices connected on the bus form together an AND-function because of pull-up resistors.

A master is controlling the bus, enabling clock and giving start and stop requests, so data transfer for MAS9560 is started with start-pulse given by a master device. As the master is changing SDI level from high to low while SCLK is high, this action is recognized as the start pulse. Stop pulse is similarly created: when SCLK is high SDI level is changed from low to high. During the data transition data line (SDI) level may not change when clock (SCLK) is high, because this is interpreted either as start or stop pulse.

Data is transmitted in bytes, one byte is 8-bit long. Several bytes can be sent one by one until the master gives stop signal.

I²C data format is shown in table 1 below. The first byte in I²C data after start pulse specifies unique device code and transfer mode. Device code is specified by 7 bits and is 1001 101 for MAS9560, last (8th) bit selects read/write-mode (r/w): high for read and low for write. After first byte is read, MAS9560 acknowledges it by pulling data line (SDI) down, keeping data line down and releasing the line only after the master driven clock line (SCLK) is again pulled down.

After the device specific code MAS9560 is set as receiver for data as described above, sub-address is given as a second byte. This addresses the initial register number, and the following byte is the data which is written to the register. In case the fourth byte is written (and no stop bit is given), MAS9560 changes to increment mode and this fourth byte is written to a following register. All registers can be written by one start-stop sequence. On-chip incremental counter is just 4-bits long. Incrementing stops at address 0x0F to prevent overflow. In write mode MAS9560 gives acknowledge pulse after every byte.

I²C bus can also be used to read register values. In this case a sequence is as follows: First byte 1001 1010 is written after start pulse (MAS9560 acknowledges) after which register address is given, which is acknowledged by device. Next a new start pulse is given by the master and byte 1001 1011 is acknowledged by MAS9560, after which register (specified in initial sequence) data is written to data bus (MSB first). After that MAS9560 gives NAK (no acknowledge) signal which continues until ACK (acknowledge) or STOP signal is given by the master. In case ACK signal is given, the incremental mode of MAS9560 is enabled and next register data is written to SDI bus by MAS9560. The data is again followed by NAK signal, and the reading sequence can be repeated or stopped.

Values of unspecified bits in registers with less than 8-bits are not set to any initial value, and their value can vary from time to time.

1st byte		2nd byte	3rd byte	4th byte
device id	r/w	Register address	code	code
1001 101	1/0	0000 a3 a2 a1 a0	xxxx xxxx	xxxx xxxx
Called as DW when Write				
Called as DR when Read				

Table 1. I²C Data Format

◆ SPI Description

Serial Peripheral Interface (SPI) bus is a 4-wire serial communication interface between a master and a slave device. SPI bus is selected by setting MODE pin to low. SCLK pin is clock, XCS pin chip select, SDI data pin and SDO data out pin. Data writing is started with pulling device specific XCS pin low, and first bit (MSB) is written at next SCLK rising edge.

The first byte defines register address and whether data will be read or write, see table 2 below. Bit 5: Read = 1 and Write = 0. Note that incremental

mode stops at address 0x0F to prevent address overflow and device reset.

The following byte written to SDI is either register input data (write mode) or it is ignored (read mode). In the read mode the selected register's data can be read from SDO pin at SCLK falling edge. Data transfer stops with rising XCS pin.

In case XCS pin is held low after two first bytes, the increment mode is enabled and the following written/read bytes can be transferred to/from the next registers. SDO output is at the high impedance state when MAS9560 is not in read mode.

Bit	D7	D6	D5	D4	D3	D2	D1	D0
Function	x	x	R/W	x	A3	A2	A1	A0

Table 2. SPI first byte

◆ I²S Description

Inter-IC Sound (I²S) bus is a 3-wire serial interface for transmission of 2-channel (stereo) Pulse Code Modulation digital data for DACs. Data is sent in 2's complement format MSB first. The receiver ignores extra bits from the transmitter, if more than 16 bits are transmitted. In case byte length is less than 16 bits, data is still 2's complement and unspecified bits are set to zero.

Word Select pin (WSI-pin) can be configured in MAS9560. The default setting is: WSI = '0' when

data for Channel 1 (left channel) is read, and WSI = '1' when Channel 2 (right channel) is read. This can be changed with POL byte (see register description for I²S Interface Control Register – p. 17).

Left justified format varies also depending on the delay before the first data byte. Default delay is one clock pulse, but this delay can be configured with DEL bit.

MAS9560 supports only Left-Justified Format.

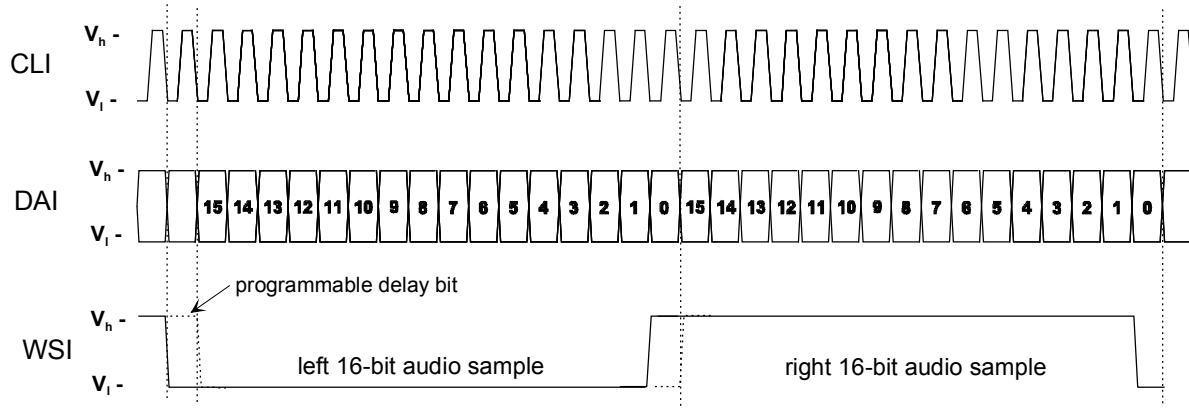

Figure 1. I²S Bus

◆ **Resetting Registers**

When I²C is used:

First register 0x00 is the reset register, writing to which will set all registers to default values. Writing to register 0x00 sets default values to all registers, after which following data will be written to registers as incrementing starts. However, note that when starting data write with the reset sequence, the byte following the reset address is unused and the byte after that is written to register 0x01 (DW-byte, Reset-address-byte, unused data byte, data byte for register 0x01). On-chip incremental counter is 4-bits long: at address 0x0F incrementing stops.

When SPI is used:

Writing to the first register (0x00) resets all registers. In case writing sequence is started with reset, the byte following the reset address is unused, similarly to I²C-mode.

Register reset can be performed externally by setting XRESET pin low.

CONTROL REGISTERS

MAS9560 has 11 on-chip registers, which are controlled through I²C- or SPI-bus (see section Control Interfaces above). Register byte length is 8 bits for all registers, however, some bits are unused

and their value is not set and can vary (they are non-repeatable). Reset register is write-only, all other registers permit read and write access.

◆ **Register Map**

Sub-Address	Register
0x00	Reset Register
0x01	Block Control Register
0x02	Mode Control Register
0x03	I ² S-Interface Control Register
0x04	Left Headphone Volume Control
0x05	Right Headphone Volume Control
0x06	Earpiece Volume Control
0x07	Loudspeaker Volume Control
0x08	Left Input Aux Gain Control
0x09	Right Input Aux Gain Control
0x0A	Ain Input Gain Control
0x0B... 0x0F	Unused

◆ Register Description

Name	Sub-Address	Direction	Default after Reset	Function
Reset Register	0x00	Write	0x00	
Reset	0xXX	Write	X	Writing to the register clears all internal registers to their default reset values. Register value cannot be read.
Block Control Register	0x01	R/W	0x00	Ignored, if Standby or Zero Power Mode
PDAC	0x01[7]	R/W	0	DAC power: 1 = on, 0 = off
PAIN	0x01[6]	R/W	0	AIN power: 1 = on, 0 = off
PAUX	0x01[5]	R/W	0	AUX power: 1 = on, 0 = off
PL	0x01[4]	R/W	0	Loudspeaker driver power: 1 = on, 0 = off
PE	0x01[3]	R/W	0	Earpiece driver power: 1 = on, 0 = off
PRH	0x01[2]	R/W	0	Right Headphone driver power: 1 = on, 0 = off
PLH	0x01[1]	R/W	0	Left Headphone driver power: 1 = on, 0 = off
PCH	0x01[0]	R/W	0	Common Headphone driver power: 1 = on, 0 = off
Mode Control Register	0x02	R/W	0x00	
-	0x02[7:5]	-	-	Unused
BYPLDO	0x02[4]	R/W	0	Bypass LDO (in non-LDO mode only): 1 = on (bypass LDO with 100 ohm on-chip resistor connected between VLDO and VBAT) 0 = off (LDO not bypassed, so on-chip resistor not connected between VLDO and VBAT)
SNLDO	0x02[3]	R/W	0	Select Non-LDO mode: 1 = on, 0 = off LDO is always disabled at Zero Power Mode
SMM	0x02[2]	R/W	0	Select Stereo/Mono mode: 1 = Mono, 0 = Stereo In Mono Mode AUXL and AUXR are combined together and only left channel DAC signal is used.

PM	0x02[1:0]	R/W	00	Power Mode [1:0] 00 Zero Power Mode 01 Standby Mode 11 Operating Mode 10 Undefined (do not use)
I²S Control Register	0x03	R/W	0x00	
-	0x03[7:5]	-	-	Unused
POL	0x03[4]	R/W	0	Invert Word Strobe Input (WSI) polarity: POL = 0 -> Left Channel @ WSI = 0 POL = 1 -> Right Channel @ WSI = 0
DEL	0x03[3]	R/W	0	Delayed Bit: 1 = Delay, 0 = no Delay
SR	0x03[2:0]	R/W	000	Sample Rate [2:0] 000, 110 or 111: sample rate defined by WSI, DAC data not filtered. SR[2:0] LP Filter -3dB frequency: 001 $f_{CLI}/128 * 0.65$ 010 $f_{CLI}/64 * 0.65$ 011 $f_{CLI}/32 * 0.65$ 100 $f_{CLI}/16 * 0.65$ 101 $f_{CLI}/8 * 0.65$ f_{CLI} refers to I2S clock (CLI pin) frequency. The above mentioned SR[2:0] register bits allow filtering the DAC output by setting the filter frequency. An example: DAC data is given in stereo mode as 16 bit data. Sampling frequency WSI = 8 kHz, and CLI frequency is $2*16*8$ kHz (2 channels, 16 bit each, 8 kHz sampling freq). Highest signal frequency is 4 kHz (according to Nyquist theorem), and thus low pass filtering can be set to 4 kHz. Now SR[2:0] = 011, which sets -3 dB frequency to 5.2 kHz ($= 2*16*8$ kHz / $32*0.65$).
Left Headphone Volume Register	0x04	R/W	0	
-	0x04[7:5]	-	-	Unused
LHV	0x04[4:0]	R/W	00000	LHV[4:0] Left Headphone volume gain 00000 Mute 00001 -30 dB ... in steps of 1.5 dB 11001...11111 6 dB

Right Headphone Volume Register	0x05	R/W	0	
-	0x05[7:5]	-	-	Unused
RHV	0x05[4:0]	R/W	00000	RHV[4:0] Right Headphone volume gain 00000 Mute 00001 -30 dB ... in steps of 1.5 dB 11001...11111 6 dB
Earpiece Volume Register	0x06	R/W	0	
-	0x06[7:5]	-	-	Unused
EV	0x06[4:0]	R/W	00000	EV[4:0] Earpiece volume gain 00000 Mute 00001 -30 dB ... in steps of 1.5 dB 11001...11111 6 dB
Loudspeaker Volume Register	0x07	R/W	0	
-	0x07[7:5]	-	-	Unused
LV	0x07[4:0]	R/W	00000	LV[4:0] Loudspeaker volume gain 00000 Mute 00001 -30 dB ... in steps of 1.5 dB 11101...11111 12 dB
Left AUX Gain Register	0x08	R/W	0	
-	0x08[7:5]	-	-	Unused
ALV	0x08[4:0]	R/W	00000	ALV[4:0] Left AUX pre-amplifier gain 00000 Mute 00001 -20 dB ... in steps of 2 dB 10101...11111 20 dB

Right AUX Gain Register	0x09	R/W	0	
-	0x09[7:5]	-	-	Unused
ARV	0x09[4:0]	R/W	00000	ARV[4:0] Right AUX pre-amplifier gain 00000 Mute 00001 -20 dB ... in steps of 2 dB 10101...11111 20 dB
AIN Gain Register	0x0A	R/W	0	
-	0x0A[7:5]	-	-	Unused
AIV	0x0A[4:0]	R/W	00000	AIV[4:0] AIN pre-amplifier gain 00000 Mute 00001 -20 dB ... in steps of 2 dB 10101...11111 20 dB

Note: Unused register bit values are undefined.

I²C BUS TIMING

LSVDD = VBAT = 3.6V, EPVDD = HPVDD = VLDO = 2.86V (LDO-mode), -40°C ≤ T_A ≤ +85°C, typical values at T_A = +27°C, unless otherwise noted

Parameter	Pin Name	Conditions	Min	Nom	Max	Unit
Input Low Voltage	SCLK, SDI				tbd	IOVDD
Input High Voltage	SCLK, SDI		tbd			IOVDD
Start Condition Setup Time	SCLK, SDI		tbd			ns
Stop Condition Setup Time	SCLK, SDI		tbd			ns
Data Setup Time before clock rising edge	SCLK, SDI		tbd			ns
Data Hold Time after clock falling edge	SCLK, SDI		tbd			ns
Clock Low Pulse Time	SCLK		tbd			ns
Clock High Pulse Time	SCLK		tbd			ns
Bus Frequency	SCLK				tbd	MHz
Data Output Low Voltage	SCLK, SDI	I _{LOAD} = 3 mA			tbd	V
Data Output High Leakage Current	SCLK, SDI	V _{SDI} = 5 V			tbd	μA
Data Output Hold Time after clock falling edge	SCLK, SDI		tbd			ns
Data Output Setup Time before clock rising edge	SCLK, SDI	f _{I2C} = 1MHz	tbd			ns

SPI BUS TIMING

LSVDD = VBAT = 3.6V, EPVDD = HPVDD = VLDO = 2.86V (LDO-mode), $-40^{\circ}\text{C} \leq T_A \leq +85^{\circ}\text{C}$, typical values at $T_A = +27^{\circ}\text{C}$, unless otherwise noted

Parameter	Pin Name	Conditions	Min	Nom	Max	Unit
Input Low voltage	SDI,				tbd	IOVDD
Input High voltage	SCLK		tbd			IOVDD
Input Impedance					tbd	pF
Input Leakage Current		0 V < Input < IOVDD	tbd		tbd	μA
Input Setup Time before clock rising edge	SDI, XCS		Tbd			ns
Input Hold Time after clock falling edge	SDI, XCS		Tbd			ns
Output Low Voltage	SDO	$I_{\text{LOAD}} = 0.5 \text{ mA}$, IOVDD = 1.8 V			tbd	V
Output High Voltage	SDO	$I_{\text{LOAD}} = -0.5 \text{ mA}$, IOVDD = 1.8 V	tbd			V
Clock Frequency, read access	SCLK, SDI, SDO	$C_{\text{LOAD}} = 20 \text{ pF}$, IOVDD = 3.3 V		tbd	tbd	MHz
Clock Frequency, read access	SCLK, SDI, SDO	$C_{\text{LOAD}} = 20 \text{ pF}$, IOVDD = 1.8 V		tbd	tbd	MHz
Clock Frequency, write access	SCLK, SDI	$C_{\text{LOAD}} = 20 \text{ pF}$, IOVDD = 3.3 V		tbd	tbd	MHz
Clock Frequency, write access	SCLK, SDI	$C_{\text{LOAD}} = 20 \text{ pF}$, IOVDD = 1.8 V		tbd	tbd	MHz

I²S BUS TIMING

LSVDD = VBAT = 3.6V, EPVDD = HPVDD = VLDO = 2.86V (LDO-mode), $-40^{\circ}\text{C} \leq T_A \leq +85^{\circ}\text{C}$, typical values at $T_A = +27^{\circ}\text{C}$, unless otherwise noted

Parameter	Pin Name	Conditions	Min	Nom	Max	Unit
Input Low Voltage	DAI,				tbd	IOVDD
Input High voltage	CLI,		tbd			IOVDD
Input Impedance	WSI				tbd	pF
Input Leakage Current		0 V < Input < IOVDD	tbd		tbd	μA
Input Setup Time before clock rising edge	DAI, WSI		tbd			ns
Input Hold Time after clock falling edge	DAI, WSI		tbd			ns
Clock Frequency (Note 1)	CLI, DAI				tbd	MHz

Note 1: I²S clock (CLI) frequency ratio will affect to DAC sampling in oversampling mode. See Control Register description (p. 18)

PACKAGE (QFN 6x6 40ld) OUTLINE

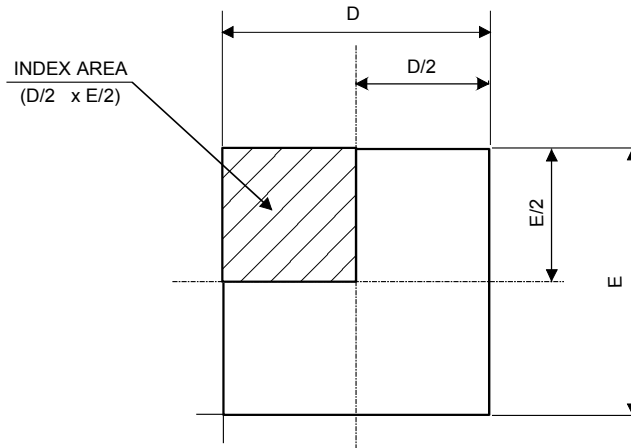

TOP VIEW

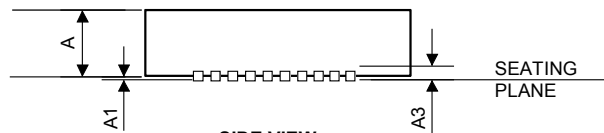

SIDE VIEW

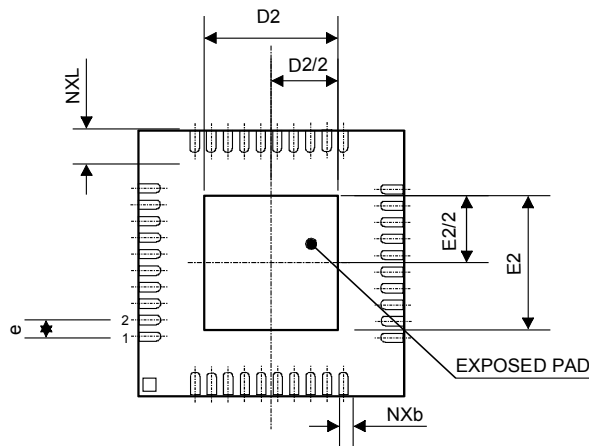

BOTTOM VIEW

Parameter	Typ	Unit
D	6	mm
E	6	mm
A	0.9	mm
A1	0.02	mm
D2	4.15	mm
E2	4.15	mm
e	0.5	mm
NXb	0.23	mm

SOLDERING INFORMATION

TBD

EMBOSSSED TAPE SPECIFICATIONS

TBD

REEL SPECIFICATIONS

TBD

ORDERING INFORMATION

Product Code	Product	Package	Comments
MAS9560A1	Stereo Audio Driver DAC	QFN 6x6 40ld	

LOCAL DISTRIBUTOR

MICRO ANALOG SYSTEMS OY CONTACTS

Micro Analog Systems Oy Kamreerintie 2, P.O. Box 51 FIN-02771 Espoo, FINLAND	Tel. +358 9 80 521 Fax +358 9 805 3213 http://www.mas-oy.com
--	--

NOTICE

Micro Analog Systems Oy reserves the right to make changes to the products contained in this data sheet in order to improve the design or performance and to supply the best possible products. Micro Analog Systems Oy assumes no responsibility for the use of any circuits shown in this data sheet, conveys no license under any patent or other rights unless otherwise specified in this data sheet, and makes no claim that the circuits are free from patent infringement. Applications for any devices shown in this data sheet are for illustration only and Micro Analog Systems Oy makes no claim or warranty that such applications will be suitable for the use specified without further testing or modification.