



2SD1803

NPN EPITAXIAL SILICON TRANSISTOR

HIGH CURRENT SWITCHING APPLICATION

■ DESCRIPTION

The UTC 2SD1803 applies to relay drivers, high-speed inverters, converters, and other general high-current switching applications.

■ FEATURES

- *Low collector-to-emitter saturation voltage.
- *High current and high f_T .
- *Excellent linearity of h_{FE} .
- *Fast switching time.

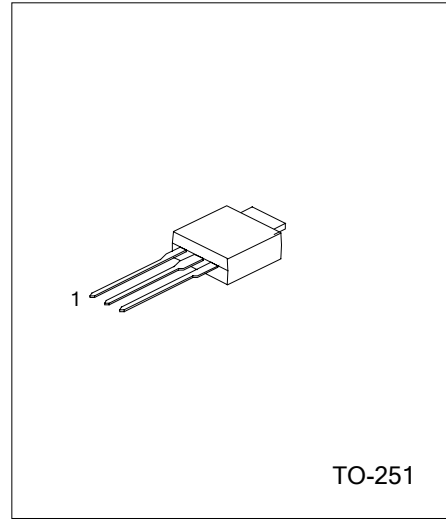

*Pb-free plating product number:2SD1803L

■ PIN CONFIGURATION

PIN NO.	PIN NAME
1	BASE
2	COLLECTOR
3	EMITTER

■ ORDERING INFORMATION

Order Number		Package	Packing
Normal	Lead free		
2SD1803-TM3-T	2SD1803L-TM3-T	TO-251	Tube

■ ABSOLUTE MAXIMUM RATINGS (Ta = 25°C)

PARAMETER	SYMBOL	RATINGS	UNIT
Collector-Base Voltage	V _{CBO}	60	V
Collector-Emitter Voltage	V _{CEO}	50	V
Emitter-Base Voltage	V _{EBO}	6	V
Collector Current	DC	I _C	5
	PULSE	I _{CM}	8
Power Dissipation	T _C =25°C	P _D	20
	T _a =25°C		1
Junction Temperature	T _J	+150	°C
Storage Temperature	T _{STG}	-40 ~ +150	°C

■ ELECTRICAL CHARACTERISTICS (Ta= 25°C, unless otherwise specified.)

PARAMETER	SYMBOL	TEST CONDITIONS	MIN	TYP	MAX	UNIT
Collector-Base Breakdown Voltage	BV _{CBO}	I _C =10μA, I _E =0	60			V
Collector-Emitter Breakdown Voltage	BV _{CEO}	I _C =1mA, R _{BE} =∞	50			V
Emitter-Base Breakdown Voltage	BV _{EBO}	I _E =10μA, I _C =0	6			V
Collector Cutoff Current	I _{CBO}	V _{CB} =40V, I _E =0			1	μA
Emitter Cutoff Current	I _{EBO}	V _{EB} =4V, I _C =0			1	μA
DC Current Gain	h _{FE1}	V _{CE} =2V, I _C =0.5A	70		400	
	h _{FE2}	V _{CE} =2V, I _C =4A	35			
Gain-Bandwidth Product	f _T	V _{CE} =5V, I _C =1A		180		MHz
Output Capacitance	C _{ob}	V _{CB} =10V, f=1MHz		40		pF
C-E Saturation Voltage	V _{CE(sat)}	I _C =3A, I _B =0.15A		220	400	mV
B-E Saturation Voltage	V _{BE(sat)}	I _C =3A, I _B =0.15A		0.95	1.3	V
Turn-on Time	t _{ON}	See Test Circuit		50		ns
Storage Time	t _S	See Test Circuit		500		ns
Fall Time	t _F	See Test Circuit		20		ns

■ CLASSIFICATION OF h_{FE} 1

RANK	Q	R	S	T
RANGE	70 ~ 140	100 ~ 200	140 ~ 280	200 ~ 400

■ TEST CIRCUIT

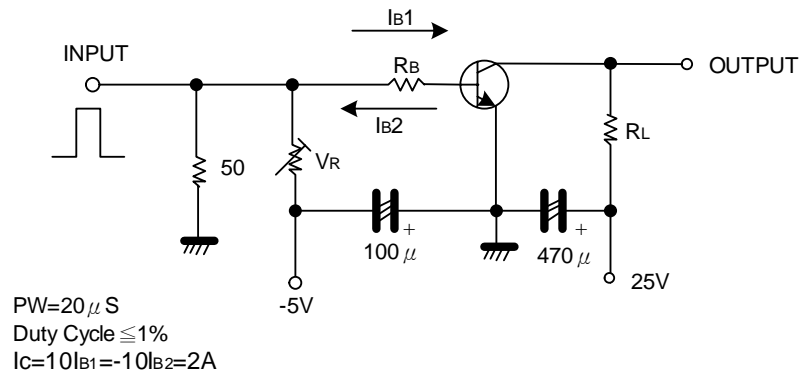

(Unit : (resistance : Ω , capacitance : F))

■ TYPICAL CHARACTERISTICS

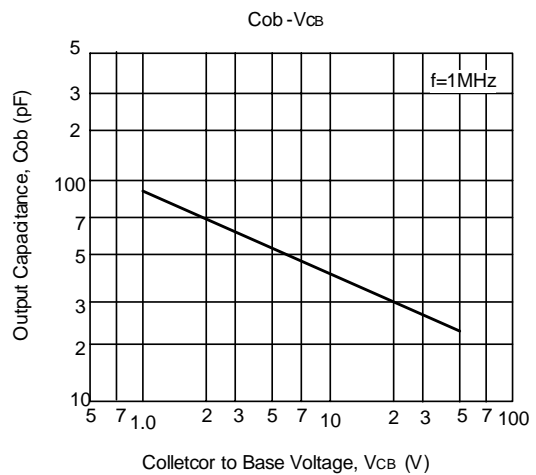
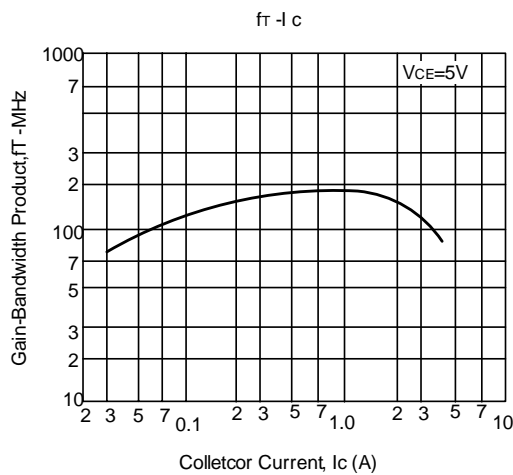
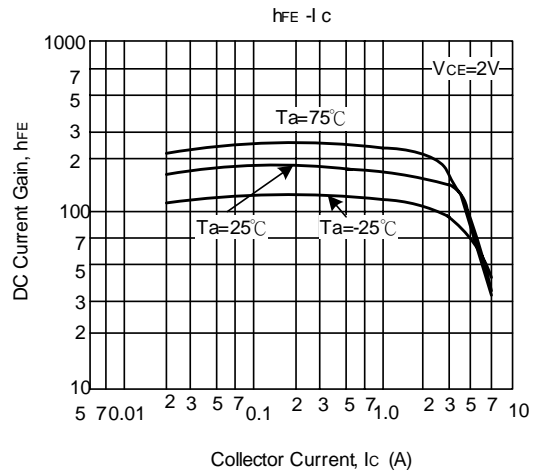
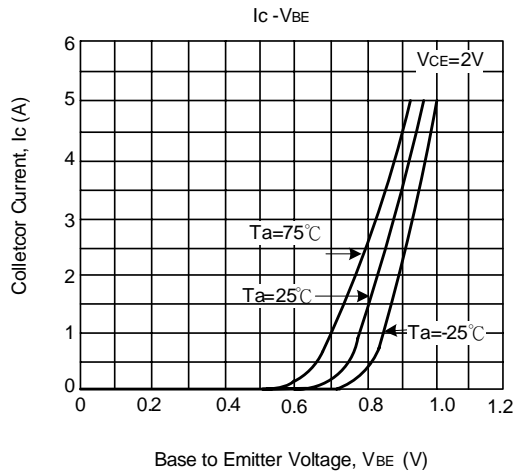
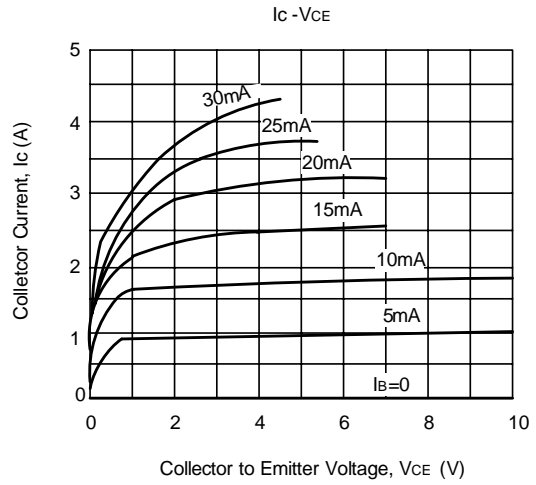
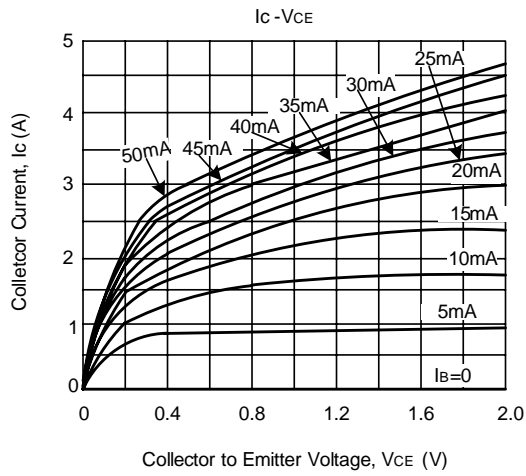

TYPICAL CHARACTERISTICS(cont.)

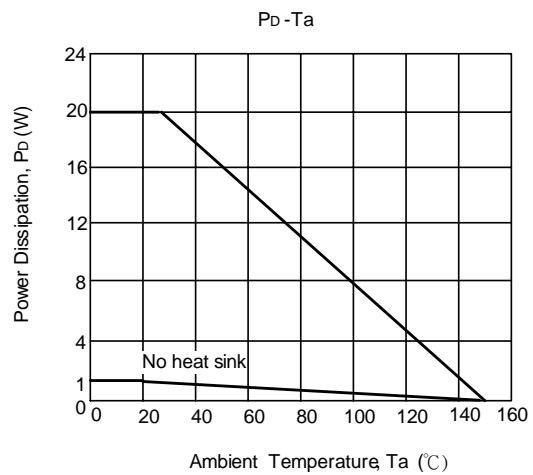
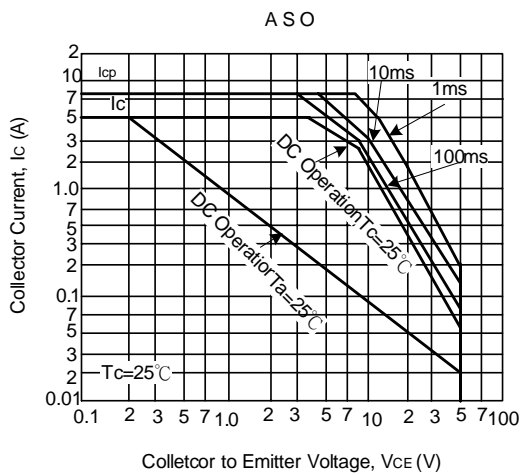
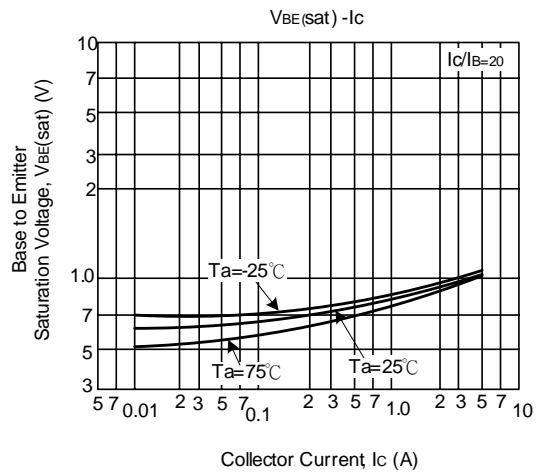
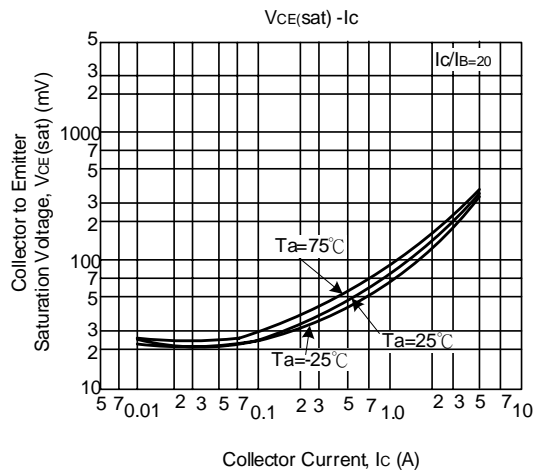

UTC assumes no responsibility for equipment failures that result from using products at values that exceed, even momentarily, rated values (such as maximum ratings, operating condition ranges, or other parameters) listed in products specifications of any and all UTC products described or contained herein. UTC products are not designed for use in life support appliances, devices or systems where malfunction of these products can be reasonably expected to result in personal injury. Reproduction in whole or in part is prohibited without the prior written consent of the copyright owner. The information presented in this document does not form part of any quotation or contract, is believed to be accurate and reliable and may be changed without notice.