



## L5101

## LINEAR INTEGRATED CIRCUIT

### WHITE LED STEP-UP CONVERTER

#### DESCRIPTION

The UTC **L5101** is a fixed frequency step-up PWM DC/DC converter and designed for white LEDS driving with a constant current to provide backlight in handheld devices. The device switches at a high frequency 1.2MHz by an internal N-channel MOSFET switch to be capable of minimum external components using.

The UTC **L5101** can drive up to 5 LEDs in series by a Li-Ion cell. Series connection of LEDS provides identical LED currents resulting in uniform brightness without ballast resistors. The low 95mV feedback voltage minimizes power loss in the current setting resistor can have better efficiency.

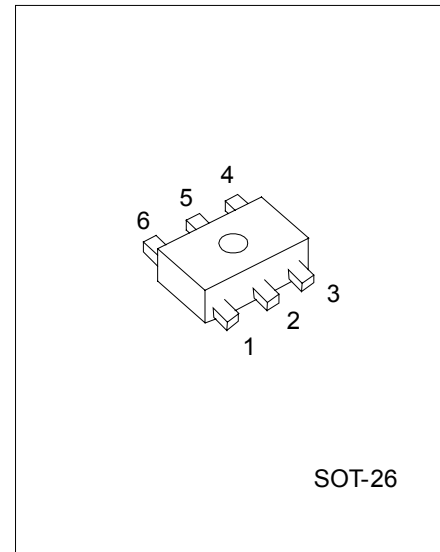

\*Pb-free plating product number: L5101L

#### FEATURES

- \* Built-In Open Circuit Protection
- \* Built-In Over Voltage Protection
- \* High Efficiency(Up to 84% at  $V_{IN}=4.2V$ , 3 LEDs,  $I_{LED}=20mA$ )
- \* 1.2MHz fixed switching frequency
- \* Low supply current: 70 $\mu$ A
- \* Matches LED current
- \* Requires tiny inductor and capacitors

#### ORDERING INFORMATION

Order Number		Package	Packing
Normal	Lead Free Plating		
L5101-AG6-R	L5101L-AG6-R	SOT-26	Tape Reel

### ■ PIN CONFIGURATION

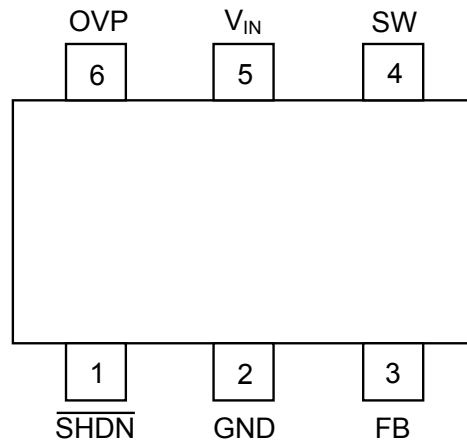

### ■ PIN DESCRIPTIONS

PIN NO.	PIN NAME	SYMBOL	DESCRIPTION
1	Shutdown	SHDN	Tie to higher than 1.5V to enable device, 0.3V or less to disable device.
2	Ground	GND	
3	Feedback	FB	Reference voltage is 95mV. Connect cathode of lowest LED and resistor here. Calculation formula: $R_{FB} = 95mV / I_{LED}$
4	Switch	SW	Connect inductor/diode here. Minimize trace area at this pin to reduce EMI.
5	Power input	V <sub>IN</sub>	Bypass V <sub>IN</sub> to GND with a capacitor sitting as close to V <sub>IN</sub> as possible.
6	Overvoltage protection	OVP	The internal MOSFET will turn off when V <sub>OUT</sub> > 27V.

■ BLOCK DIAGRAM

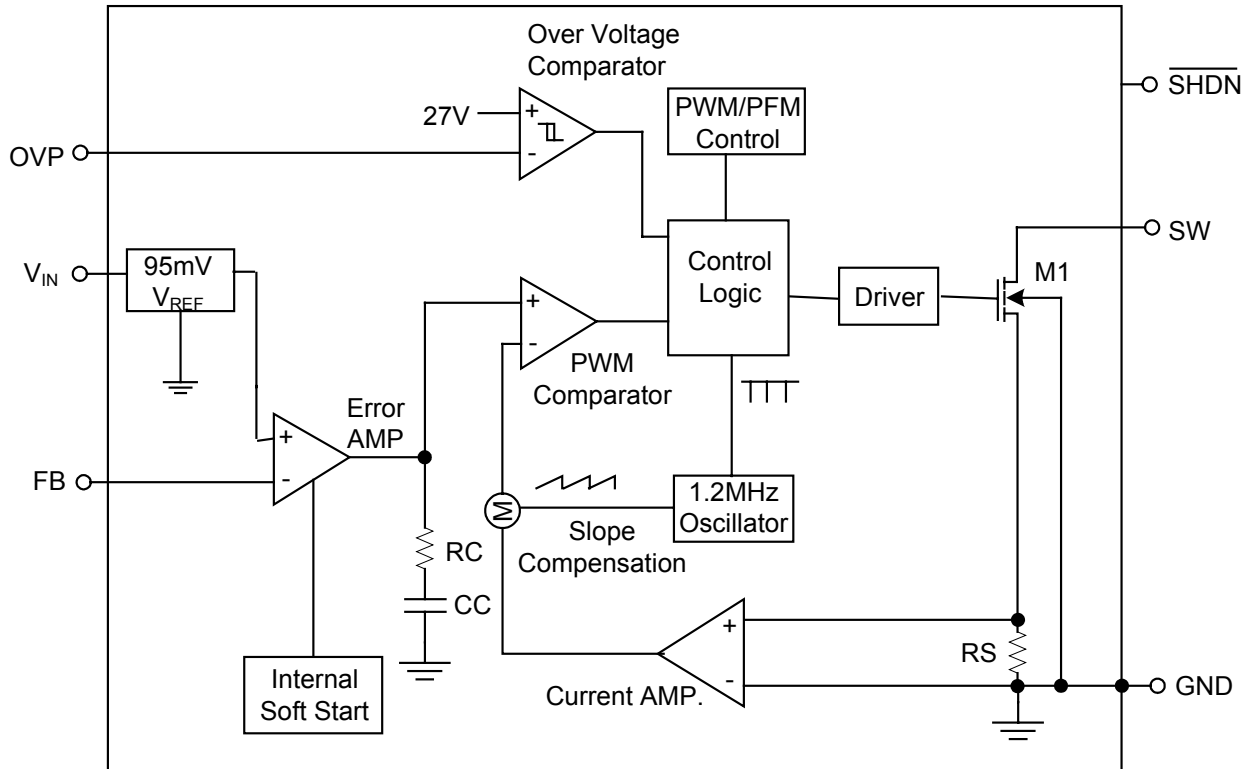

### ■ ABSOLUTE MAXIMUM RATINGS

PARAMETER	SYMBOL	RATINGS	UNIT
Input Voltage	$V_{IN}$	6	V
SW Voltage	$V_{SW}$	33	V
FB Voltage	$V_{FB}$	6	V
SHDN Voltage	$\overline{V_{SHDN}}$	6	V
OVP Voltage	$V_{OVP}$	34	V
Junction Temperature	$T_J$	+125	
Operating Temperature Range	$T_{OPR}$	0 ~ +70	
Storage Temperature Range	$T_{STG}$	-40 ~ +150	

Note 1. Absolute maximum ratings are those values beyond which the device could be permanently damaged.

Absolute maximum ratings are stress ratings only and functional device operation is not implied.

2. The device is guaranteed to meet performance specification within 0 ~ +70 operating temperature range and assured by design from -20 ~ +85 .

### ■ ELECTRICAL CHARACTERISTICS ( $\overline{V_{SHDN}}=3V$ , $V_{IN}=3V$ , $T_a=25$ , unless otherwise specified.)

PARAMETER	SYMBOL	TEST CONDITIONS	MIN	TYP	MAX	UNIT
Operating Voltage	$V_{IN}$		2.5		5.5	V
Supply Current	$I_{IN}$	Switching		1	5	mA
		Non switching		70	100	μA
		$\overline{V_{SHDN}}=0V$		0.1	1.0	
<b>ERROR AMPLIFIER</b>						
Feedback Voltage	$V_{FB}$		85	95	105	mV
FB Input Bias Current	$I_{FB}$	$V_{FB}=95mV$		1		nA
<b>OSCILLATOR</b>						
Switching Frequency	$f_{SW}$		0.8	1.2	1.6	MHz
Maximum Duty Cycle	DC		85	90		%
<b>POWER SWITCH</b>						
SW ON Resistance	$R_{ON(SW)}$			1.4	5	Ω
Switch Leakage Current	$I_{LEAK(SW)}$	$V_{SW}=33V$		0.1	1	μA
<b>CONTROL INPUT</b>						
Shutdown Voltage	High	$V_{IH(\overline{SHDN})}$	ON	1.5		V
	Low	$V_{IL(\overline{SHDN})}$	OFF		0.3	V
<b>OVER VOLTAGE PROTECTION</b>						
OVP Input Resistance	$R_{IN(OVP)}$		0.6	1.2	1.8	MΩ
OVP Threshold	$V_{THR(OVP)}$	1V Hysteresis typical	22	27	32	V

### ■ TEST CIRCUIT

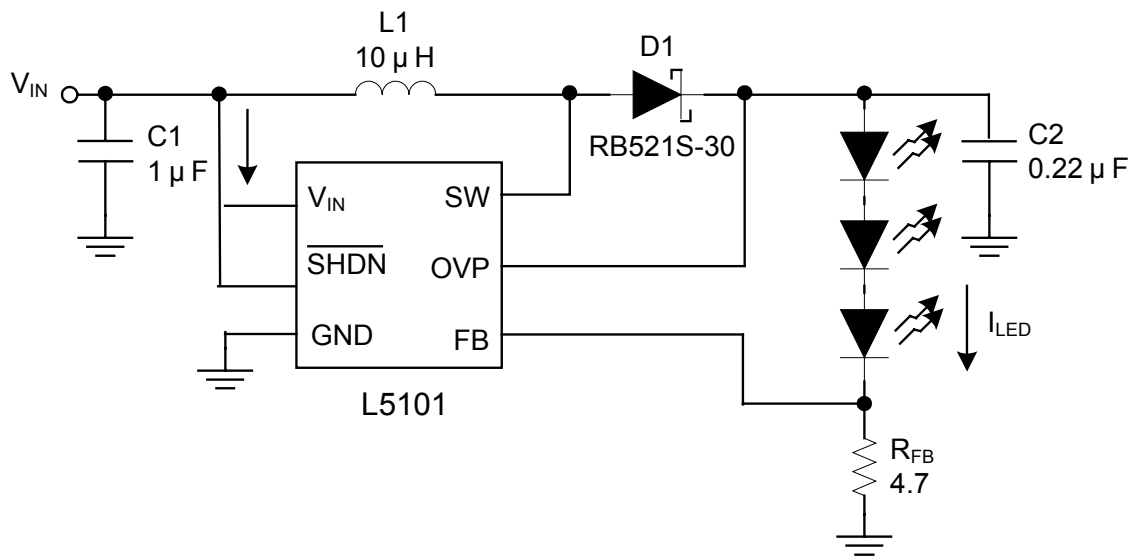

## APPLICATION INFORMATION

### Recommended Component Selection

- **Inductor Selection:** A 10μH inductor is recommended for most applications.
- **Capacitor Selection:** The small size of ceramic capacitors (1μF input with 1μF output ) are sufficient, X5R and X7R types are recommended
- **Diode Selection:** An Schottky diode rated at 100mA ~ 200mA is sufficient for most applications.

### LED Current Control

A feedback resistor (precision 1% recommended) as feedback resistor control the LED current.(R<sub>FB</sub> in Figure 1)

- Feedback reference voltage : 95mV.
- LED current is 95mV/R<sub>FB</sub>.
- The formula for R<sub>FB</sub> selection :  $R_{FB} = 95mV / I_{LED}$

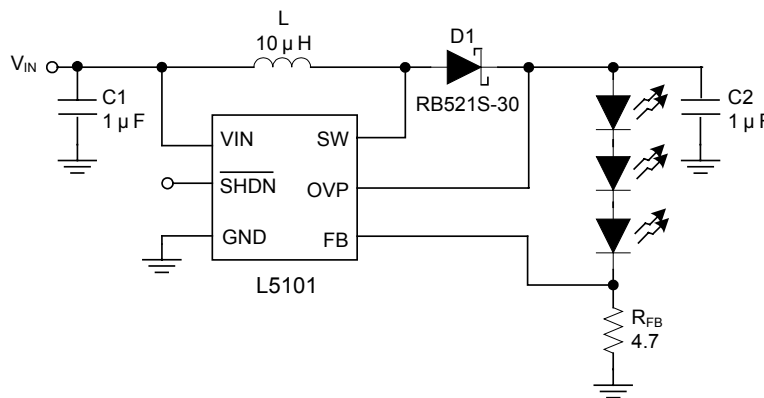

Fig.1 Dimming Control with a PWM Signal

### Open-Circuit Protection

When a high output voltage exceeds maximum 33V, the built-in OVP (Over Voltage Protection) will be triggered to prevent the damage resulting from an open circuit condition.

### Dimming Control

There are three different ways of dimming control circuits as follows:

1. Using a PWM signal

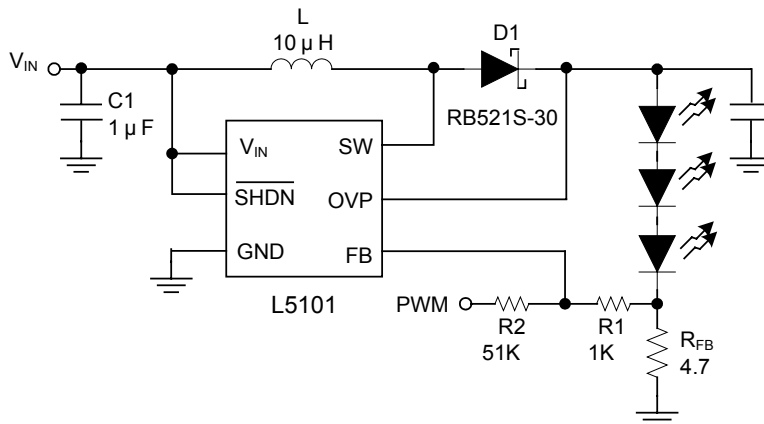

Fig.2 Dimming Control Using a PWM Signal

## ■ APPLICATION INFORMATION(Cont.)

### 2. Using a DC Voltage

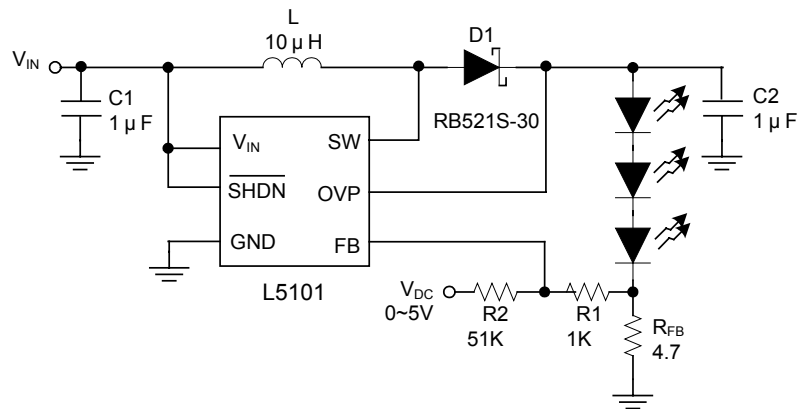

Fig.3 Dimming Control Using a DC Voltage

### 3. Using a Filtered PWM Signal

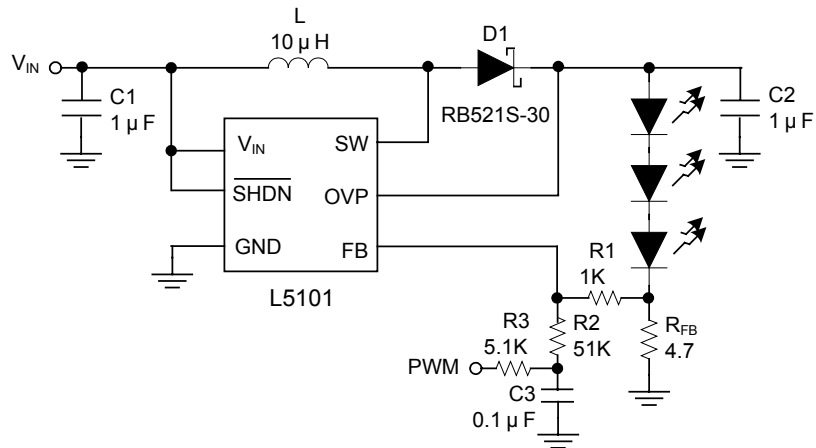
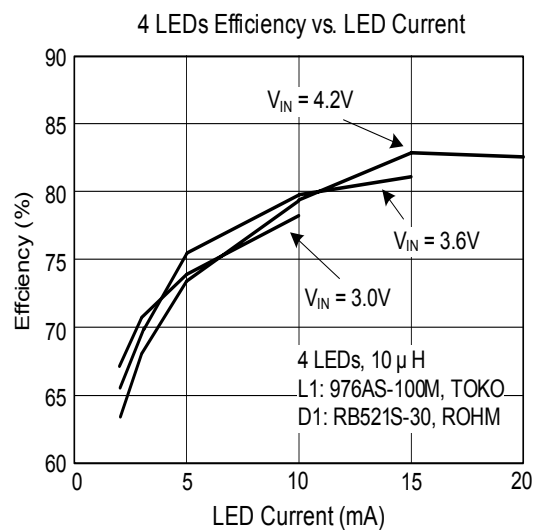
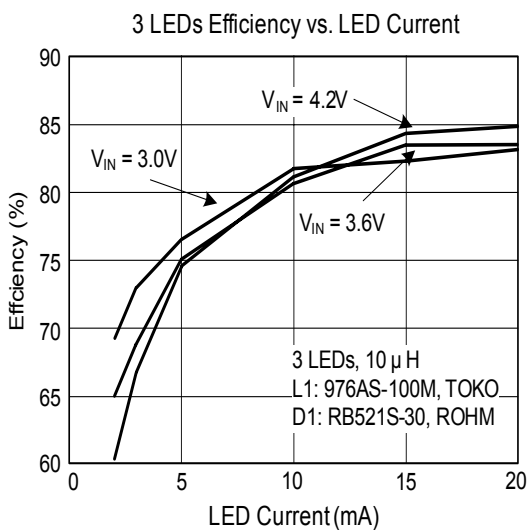
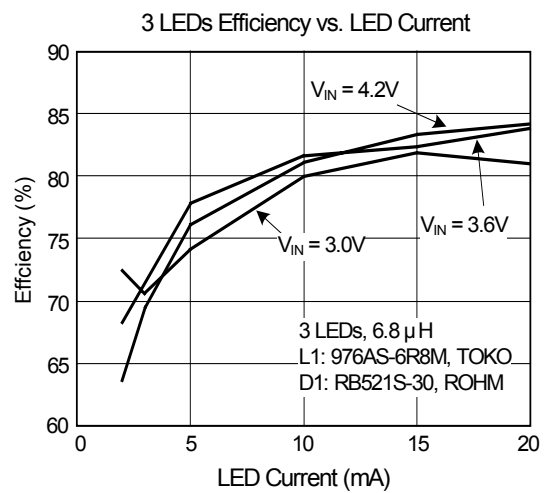
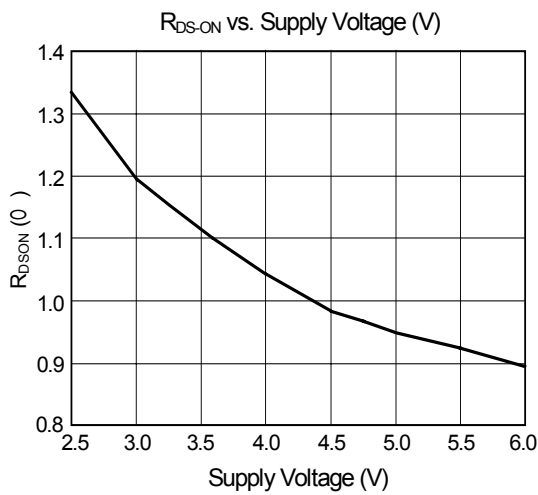
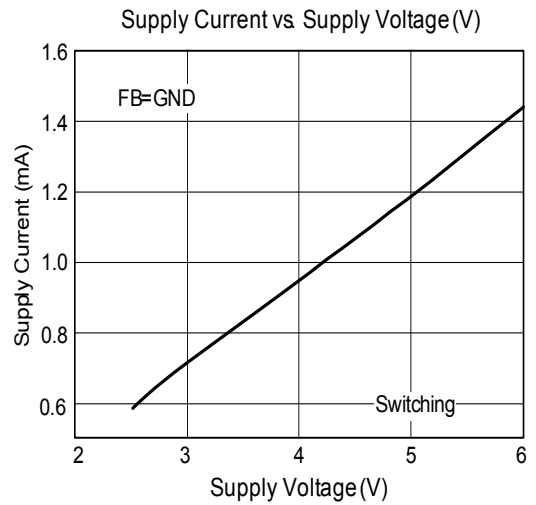
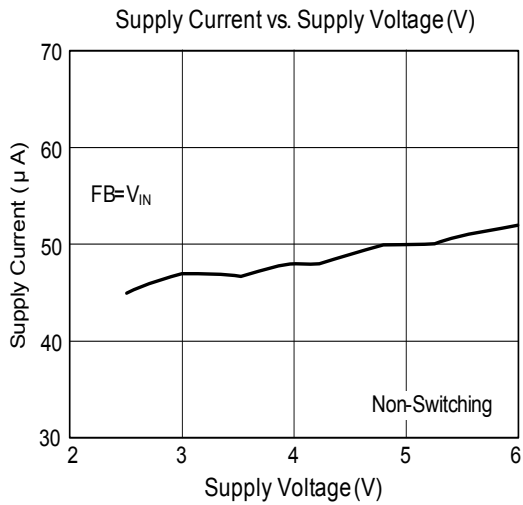

Fig.4 Dimming Control Using a Filter PWM Signal

### TYPICAL CHARACTERISTICS





## ■ TYPICAL CHARACTERISTICS(cont.)

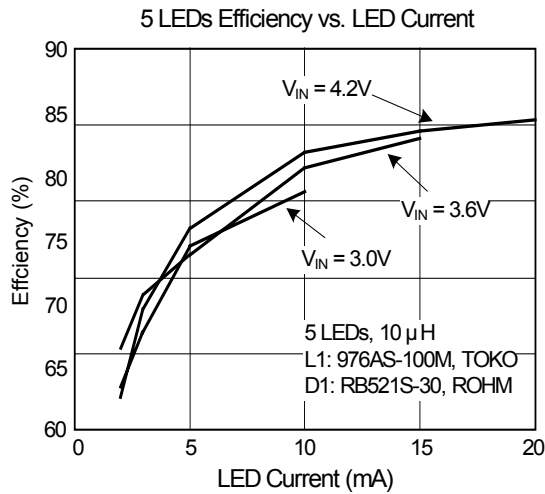

UTC assumes no responsibility for equipment failures that result from using products at values that exceed, even momentarily, rated values (such as maximum ratings, operating condition ranges, or other parameters) listed in products specifications of any and all UTC products described or contained herein. UTC products are not designed for use in life support appliances, devices or systems where malfunction of these products can be reasonably expected to result in personal injury. Reproduction in whole or in part is prohibited without the prior written consent of the copyright owner. The information presented in this document does not form part of any quotation or contract, is believed to be accurate and reliable and may be changed without notice.