

MC10H645

1:9 TTL Clock Driver

Description

The MC10H645 is a single supply, low skew, TTL I/O 1:9 Clock Driver. Devices in the H600 clock driver family utilizes the PLCC-28 for optimal power and signal pin placement.

The device features a 24 mA TTL output stage with AC performance specified into a 50 pF load capacitance. A 2:1 input Mux is provided on chip to allow for distributing both system and diagnostic clock signals or designing clock redundancy into a system. With the SEL input held LOW the DO input will be selected, while the D1 input is selected when the SEL input is forced HIGH.

Features

- Low Skew Typically 0.65 ns Within Device
- Guaranteed Skew Spec 1.25 ns Part-to-Part
- Input Clock Muxing
- Differential ECL Internal Design
- Single Supply
- Extra TTL and ECL Power/Ground Pins
- Pb-Free Packages are Available*



ON Semiconductor®

<http://onsemi.com>

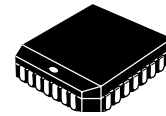

PLCC
FN SUFFIX
CASE 776

MARKING DIAGRAM

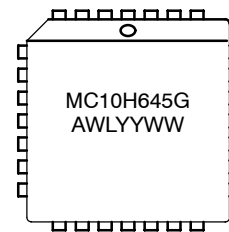

A = Assembly Location
WL = Wafer Lot
YY = Year
WW = Work Week
G = Pb-Free Package

ORDERING INFORMATION

See detailed ordering and shipping information in the package dimensions section on page 4 of this data sheet.

*For additional information on our Pb-Free strategy and soldering details, please download the ON Semiconductor Soldering and Mounting Techniques Reference Manual, SOLDERRM/D.

MC10H645

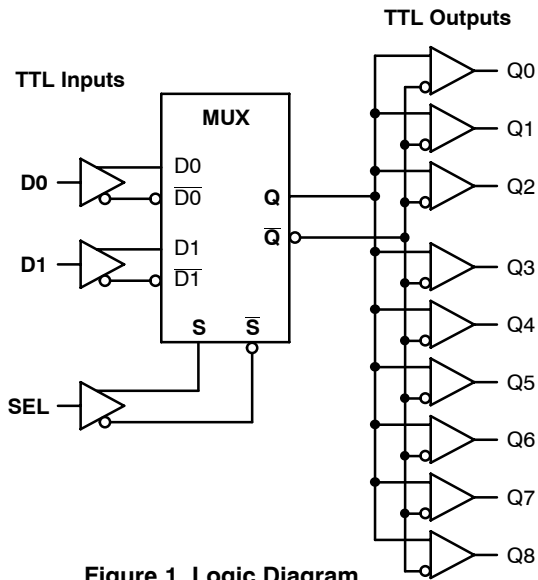

Figure 1. Logic Diagram

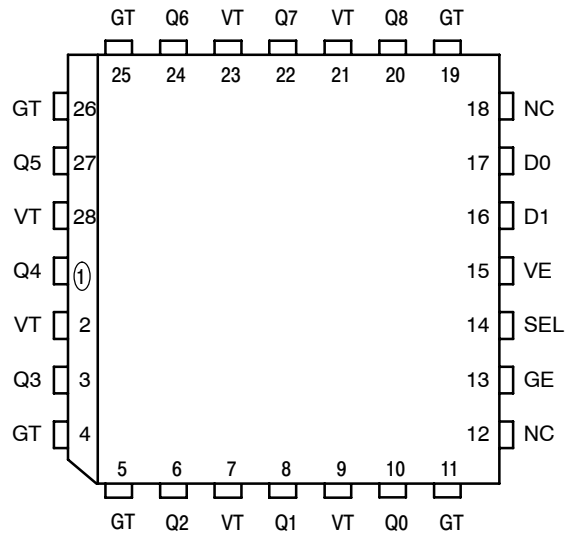

Figure 2. Pinout: 28-Lead PLCC (Top View)

Table 1. PIN NAMES

PIN	FUNCTION
GT	TTL Ground (0 V)
VT	TTL V _{CC} (+5.0 V)
VE	ECL V _{CC} (+5.0 V)
GE	ECL Ground (0 V)
Dn	TTL Signal Input
Q0 – Q8	TTL Signal Outputs
SEL	TTL Mux Select

Table 2. PIN DESCRIPTIONS

Pin	Symbol	Description	Pin	Symbol	Description
1	Q4	Signal Output (TTL)	15	VE	ECL V _{CC} (+5.0 V)
2	VT	TTL V _{CC} (+5.0 V)	16	D1	Signal Input (TTL)
3	Q3	Signal Output (TTL)	17	D0	Signal Input (TTL)
4	GT	TTL Ground (0 V)	18	NC	No Connection
5	GT	TTL Ground (0 V)	19	GT	TTL Ground (0 V)
6	Q2	Signal Output (TTL)	20	Q8	Signal Output (TTL)
7	VT	TTL V _{CC} (+5.0 V)	21	VT	TTL V _{CC} (+5.0 V)
8	Q1	Signal Output (TTL)	22	Q7	Signal Output (TTL)
9	VT	TTL V _{CC} (+5.0 V)	23	VT	TTL V _{CC} (+5.0 V)
10	Q0	Signal Output (TTL)	24	Q6	Signal Output (TTL)
11	GT	TTL Ground (0 V)	25	GT	TTL Ground (0 V)
12	NC	No Connection	26	GT	TTL Ground (0 V)
13	GE	ECL Ground	27	Q5	Signal Output (TTL)
14	SEL	Select Input (TTL)	28	VT	TTL V _{CC} (+5.0 V)

Table 3. TRUTH TABLE

D0	D1	SEL	Q
L	X	L	L
H	X	L	H
X	L	H	L
X	H	H	H

MC10H645

Table 4. ABSOLUTE RATINGS (Do not exceed)

Symbol	Characteristic	Value	Unit
VE (ECL)	Power Supply Voltage	-0.5 to +7.0	V
VT (TTL)	Power Supply Voltage	-0.5 to +7.0	V
VI (TTL)	Input Voltage	-0.5 to +7.0	V
V _{out}	Disabled 3-State Output	0.0 to V _T	V
T _{stg}	Storage Temperature	-65 to 150	°C
T _{amb}	Operating Temperature	0.0 to +85	°C

Maximum ratings are those values beyond which device damage can occur. Maximum ratings applied to the device are individual stress limit values (not normal operating conditions) and are not valid simultaneously. If these limits are exceeded, device functional operation is not implied, damage may occur and reliability may be affected.

Table 5. DC CHARACTERISTICS (V_T = V_E = 5.0 V ±5%)

Symbol	Characteristic	0°C		25°C		85°C		Unit	Condition	
		Min	Max	Min	Max	Min	Max			
I _{EE}	Power Supply Current	ECL		30		30		30	mA	VE Pin
I _{CCH}		TTL		30		30		30	mA	Total all VT pins
I _{CCL}				35		35		35	mA	
V _{OH}	Output HIGH Voltage	2.5 2.0		2.5 2.0		2.5 2.0		V	I _{OH} = -3.0 mA I _{OH} = -15 mA	
V _{OL}	Output LOW Voltage		0.5		0.5		0.5	V	I _{OL} = 24 mA	
I _{OS}	Output Short Circuit Current	-100	-225	-100	-225	-100	-225	mA	V _{OUT} = 0 V	

NOTE: Device will meet the specifications after thermal equilibrium has been established when mounted in a test socket or printed circuit board with maintained transverse airflow greater than 500 lfpm. Electrical parameters are guaranteed only over the declared operating temperature range. Functional operation of the device exceeding these conditions is not implied. Device specification limit values are applied individually under normal operating conditions and not valid simultaneously.

Table 6. TTL DC CHARACTERISTICS (V_T = V_E = 5.0 V ±5%)

Symbol	Characteristic	0°C		25°C		85°C		Unit	Condition
		Min	Max	Min	Max	Min	Max		
V _{IH} V _{IL}	Input HIGH Voltage Input LOW Voltage	2.0	0.8	2.0	0.8	2.0	0.8	V	
I _{IH}	Input HIGH Current		20 100		20 100		20 100	μA	V _{IN} = 2.7 V V _{IN} = 7.0 V
I _{IL}	Input LOW Current		-0.6		-0.6		-0.6	mA	V _{IN} = 0.5 V
V _{OH}	Output HIGH Voltage	2.5 2.0		2.5 2.0		2.5 2.0		V	I _{OH} = -3.0 mA I _{OH} = -24 mA
V _{OL}	Output LOW Voltage		0.5		0.5		0.5	V	I _{OL} = 24 mA
V _{IK}	Input Clamp Voltage		-1.2		-1.2		-1.2	V	I _{IN} = -18 mA
I _{OS}	Output Short Circuit Current	-100	-225	-100	-225	-100	-225	mA	V _{OUT} = 0 V

NOTE: Device will meet the specifications after thermal equilibrium has been established when mounted in a test socket or printed circuit board with maintained transverse airflow greater than 500 lfpm. Electrical parameters are guaranteed only over the declared operating temperature range. Functional operation of the device exceeding these conditions is not implied. Device specification limit values are applied individually under normal operating conditions and not valid simultaneously.

MC10H645

Table 7. AC CHARACTERISTICS ($V_T = V_E = 5.0\text{ V} \pm 5\%$)

Symbol	Characteristic		0°C		25°C		85°C		Unit	Condition
			Min	Max	Min	Max	Min	Max		
t _{PLH}	Propagation Delay D ₀ to Output Only	Q0-Q8	4.8	5.8	4.8	5.8	5.2	6.2	ns	CL = 50 pF
t _{PLH}	Propagation Delay D ₁ to Output		4.8	5.8	4.8	5.8	5.2	6.2	ns	
t _{PHL}	Propagation Delay D ₀ to Output D ₁ to Output		4.8 4.8	5.8 5.8	4.8 4.8	5.8 5.8	5.2 5.2	6.2 6.2	ns	
t _{skpp}	Part-to-Part Skew D ₀ to Output Only			1.0		1.0		1.0	ns	
t _{skwd} *	Within-Device Skew D ₀ to Output Only			0.65		0.65		0.65	ns	
t _{PLH}	Propagation Delay SEL to Q	Q0-Q8	4.5	6.5	5.0	7.0	5.2	7.2	ns	CL = 50 pF
t _r t _f	Output Rise/Fall Time 0.8V to 2.0V	Q0-Q8	0.5 0.5	2.5 2.5	0.5 0.5	2.5 2.5	0.5 0.5	2.5 2.5	ns	CL = 50 pF
t _S	Setup Time SEL to D		1.0		1.0		1.0		ns	

NOTE: Device will meet the specifications after thermal equilibrium has been established when mounted in a test socket or printed circuit board with maintained transverse airflow greater than 500 lfm. Electrical parameters are guaranteed only over the declared operating temperature range. Functional operation of the device exceeding these conditions is not implied. Device specification limit values are applied individually under normal operating conditions and not valid simultaneously.

*Within-Device Skew defined as identical transitions on similar paths through a device.

Table 8. DUTY CYCLE SPECIFICATIONS ($0^\circ\text{C} \leq T_A \leq 85^\circ\text{C}$; Duty Cycle Measured Relative to 1.5 V)

Symbol	Characteristic		Min	Nom	Max	Unit	Condition
PW	Range of V _{CC} and CL to Meet Min Pulse Width (HIGH or LOW) at f _{out} ≤ 50MHz	V _{CC} CL PW	4.875 10.0 9.0	5.0	5.125 50.0 11.0	V pF ns	All Outputs

ORDERING INFORMATION

Device	Package	Shipping [†]
MC10H645FN	PLCC-28	37 Units / Rail
MC10H645FNG	PLCC-28 (Pb-Free)	37 Units / Rail
MC10H645FNR2	PLCC-28	500 / Tape & Reel
MC10H645FNR2G	PLCC-28 (Pb-Free)	500 / Tape & Reel

[†]For information on tape and reel specifications, including part orientation and tape sizes, please refer to our Tape and Reel Packaging Specifications Brochure, BRD8011/D.

MC10H645

PACKAGE DIMENSIONS

PLCC-28
FN SUFFIX
CASE 776-02
ISSUE E

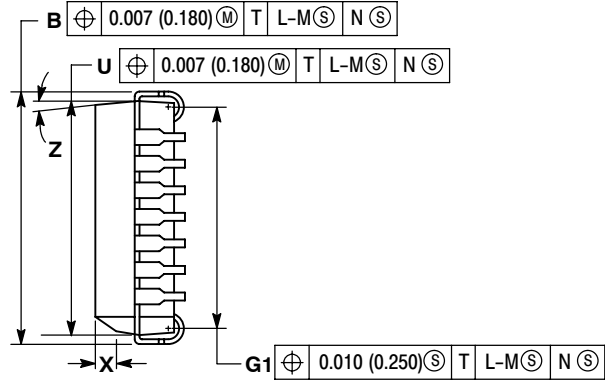
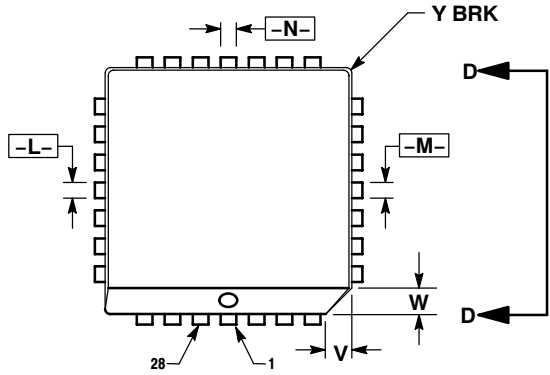

VIEW D-D

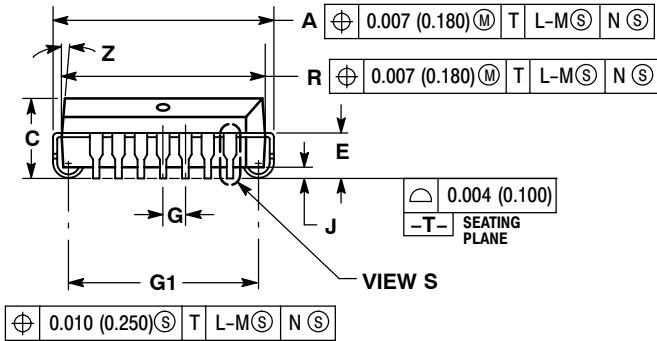

VIEW S

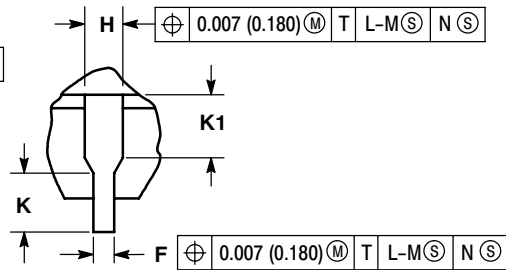

VIEW S

NOTES:

- DATUMS -L-, -M-, AND -N- DETERMINED WHERE TOP OF LEAD SHOULDER EXITS PLASTIC BODY AT MOLD PARTING LINE.
- DIMENSION G1, TRUE POSITION TO BE MEASURED AT DATUM -T-, SEATING PLANE.
- DIMENSIONS R AND U DO NOT INCLUDE MOLD FLASH. ALLOWABLE MOLD FLASH IS 0.010 (0.250) PER SIDE.
- DIMENSIONING AND TOLERANCING PER ANSI Y14.5M, 1982.
- CONTROLLING DIMENSION: INCH.
- THE PACKAGE TOP MAY BE SMALLER THAN THE PACKAGE BOTTOM BY UP TO 0.012 (0.300). DIMENSIONS R AND U ARE DETERMINED AT THE OUTERMOST EXTREMES OF THE PLASTIC BODY EXCLUSIVE OF MOLD FLASH, TIE BAR BURRS, GATE BURRS AND INTERLEAD FLASH, BUT INCLUDING ANY MISMATCH BETWEEN THE TOP AND BOTTOM OF THE PLASTIC BODY.
- DIMENSION H DOES NOT INCLUDE DAMBAR PROTRUSION OR INTRUSION. THE DAMBAR PROTRUSION(S) SHALL NOT CAUSE THE H DIMENSION TO BE GREATER THAN 0.037 (0.940). THE DAMBAR INTRUSION(S) SHALL NOT CAUSE THE H DIMENSION TO BE SMALLER THAN 0.025 (0.635).

DIM	INCHES		MILLIMETERS	
	MIN	MAX	MIN	MAX
A	0.485	0.495	12.32	12.57
B	0.485	0.495	12.32	12.57
C	0.165	0.180	4.20	4.57
E	0.090	0.110	2.29	2.79
F	0.013	0.019	0.33	0.48
G	0.050 BSC		1.27 BSC	
H	0.026	0.032	0.66	0.81
J	0.020	---	0.51	---
K	0.025	---	0.64	---
R	0.450	0.456	11.43	11.58
U	0.450	0.456	11.43	11.58
V	0.042	0.048	1.07	1.21
W	0.042	0.048	1.07	1.21
X	0.042	0.056	1.07	1.42
Y	---	0.020	---	0.50
Z	2°	10°	2°	10°
G1	0.410	0.430	10.42	10.92
K1	0.040	---	1.02	---

MC10H645

ON Semiconductor and  are registered trademarks of Semiconductor Components Industries, LLC (SCILLC). SCILLC reserves the right to make changes without further notice to any products herein. SCILLC makes no warranty, representation or guarantee regarding the suitability of its products for any particular purpose, nor does SCILLC assume any liability arising out of the application or use of any product or circuit, and specifically disclaims any and all liability, including without limitation special, consequential or incidental damages. "Typical" parameters which may be provided in SCILLC data sheets and/or specifications can and do vary in different applications and actual performance may vary over time. All operating parameters, including "Typicals" must be validated for each customer application by customer's technical experts. SCILLC does not convey any license under its patent rights nor the rights of others. SCILLC products are not designed, intended, or authorized for use as components in systems intended for surgical implant into the body, or other applications intended to support or sustain life, or for any other application in which the failure of the SCILLC product could create a situation where personal injury or death may occur. Should Buyer purchase or use SCILLC products for any such unintended or unauthorized application, Buyer shall indemnify and hold SCILLC and its officers, employees, subsidiaries, affiliates, and distributors harmless against all claims, costs, damages, and expenses, and reasonable attorney fees arising out of, directly or indirectly, any claim of personal injury or death associated with such unintended or unauthorized use, even if such claim alleges that SCILLC was negligent regarding the design or manufacture of the part. SCILLC is an Equal Opportunity/Affirmative Action Employer. This literature is subject to all applicable copyright laws and is not for resale in any manner.

PUBLICATION ORDERING INFORMATION

LITERATURE FULFILLMENT:

Literature Distribution Center for ON Semiconductor
P.O. Box 61312, Phoenix, Arizona 85082-1312 USA

Phone: 480-829-7710 or 800-344-3860 Toll Free USA/Canada

Fax: 480-829-7709 or 800-344-3867 Toll Free USA/Canada

Email: orderlit@onsemi.com

N. American Technical Support: 800-282-9855 Toll Free
USA/Canada

Japan: ON Semiconductor, Japan Customer Focus Center
2-9-1 Kamimeguro, Meguro-ku, Tokyo, Japan 153-0051

Phone: 81-3-5773-3850

ON Semiconductor Website: <http://onsemi.com>

Order Literature: <http://www.onsemi.com/litorder>

For additional information, please contact your
local Sales Representative.