

16-bit Proprietary Microcontroller

CMOS

F²MC-16LX MB90820 Series

MB90822/F822/F823/V820

■ DESCRIPTION

The MB90820 series is a line of general-purpose, Fujitsu 16-bit microcontrollers designed for process control applications which require high-speed real-time processing, such as consumer products.

While inheriting the AT architecture of the F²MC* family, the instruction set for the F²MC-16LX CPU core of the MB90820 series incorporates additional instructions for high-level languages, supports extended addressing modes, and contains enhanced multiplication and division instructions as well as a substantial collection of improved bit manipulation instructions. In addition, the MB90820 series has an on-chip 32-bit accumulator which enables processing of long-word data.

The peripheral resources integrated in the MB90820 series include : an 8/10-bit A/D converter, 8-bit D/A converters, UARTs (SCI) 0, 1, multi-functional timer (16-bit free-running timer, input capture units (ICUs) 0 to 3, output compare units (OCUs) 0 to 5, 16-bit PPG timer 0, waveform generator), 16-bit PPG timer 1, 2, PWC 0, 1, 16-bit reload timer 0, 1 and DTP/external interrupt.

*: F²MC stands for FUJITSU Flexible Microcontroller, a registered trademark of FUJITSU LIMITED.

■ FEATURES

- Minimum execution time of instruction : 42 ns / 4 MHz oscillation (uses PLL clock multiplication) maximum multiplier = 6
- Maximum memory space
16M bytes
Linear/bank access

(Continued)

■ PACKAGES

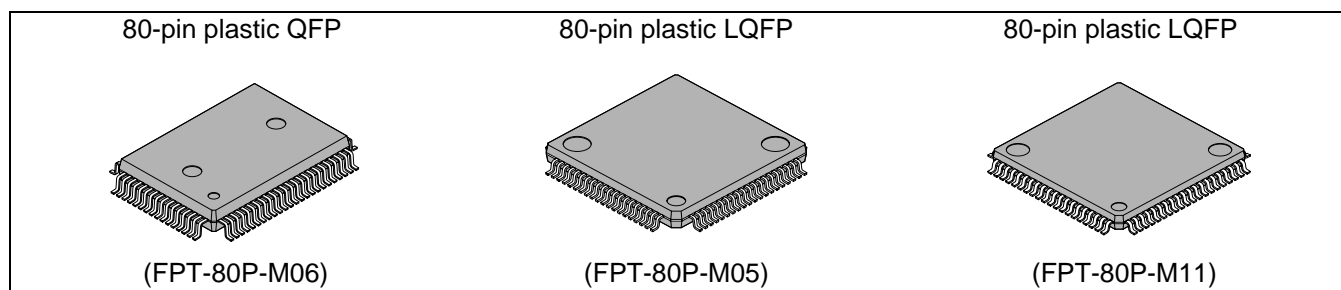

MB90820 Series

(Continued)

- Instruction set optimized for controller applications
 - Supported data types : bit, byte, word, and long-word types
 - Standard addressing modes : 23 types
 - 32-bit accumulator enhancing high-precision operations
 - Enhanced multiplication/division and RETI instructions
- Enhanced high level language (C) and multi-tasking support instructions
 - Use of a system stack pointer
 - Symmetrical instruction set and barrel shift instructions
- Program patch function (for two address pointers)
- Increased execution speed : 4-byte instruction queue
- Powerful interrupt function
 - Up to eight priority levels programmable
 - External interrupt inputs : 8 lines
- Automatic data transmission function independent of CPU operation
 - Up to 16 channels for the extended intelligent I/O service
 - DTP request inputs : 8 lines
- Internal ROM
 - FLASH : 64/128K bytes with flash security
 - MASKROM : 64K bytes
- Internal RAM
 - EVA : 16K bytes
 - FLASH : 4K bytes
 - MASKROM : 4K bytes
- General-purpose ports
 - Up to 66 channels (pull-up resistor settable input for : 32 channels)
- A/D Converter (RC) : 16 channels
 - 8/10-bit resolution selectable
 - Conversion time : Min 3 μ s at 24 MHz operating clock (including sampling time)
- 8-bit D/A Converter : 2 channels
- UART : 2 channels
- 16-bit PPG : 3 channels
 - Mode switching function provided (PWM mode or one-shot mode)
 - Channel 0 can be worked with multi-functional timer or independently
- 16-bit reload timer : 2 channels
- 16-bit PWC timer : 2 channels
- Multi-functional timer
 - Input capture : 4 channels
 - Output compare with selectable buffer : 6 channels
 - Free-running timer with up or up-down mode selection and selectable buffer: 1 channel
 - 16-bit PPG : 1 channel
 - Waveform generator : (16-bit timer : 3 channels, 3-phase waveform or dead time)
- Timebase counter/watchdog timer : 18-bit
- Low-power consumption mode :
 - Sleep mode
 - Stop mode
 - CPU intermittent operation mode

(Continued)

(Continued)

- Package :
 - LQFP-80 (FPT-80P-M05 : 0.50 mm pitch)
 - LQFP-80 (FPT-80P-M11 : 0.65 mm pitch)
 - QFP-80 (FPT-80P-M06 : 0.80 mm pitch)
- CMOS technology

MB90820 Series

■ PRODUCT LINEUP

Part number Item	MB90V820	MB90F822	MB90F823	MB90822
Classification	Development /evaluation product	Mass-produced products (Flash ROM with flash security)		Mass-produced product (Mask ROM)
ROM size	—	64K bytes	128K bytes	64K bytes
RAM size	16K bytes	4K bytes		
CPU function	Number of instruction : 351 Minimum execution time : 42 ns / 4 MHz (PLL x 6) Addressing mode : 23 Data bit length : 1, 8, 16 bits Maximum memory space: 16M bytes			
I/O port	I/O port (CMOS) : 66			
PWC	Pulse width counter timer : 2 channels Timer function (select the counter timer from three internal clocks) Various pulse width measuring function (H pulse width, L pulse width, rising edge to falling edge period, falling edge to rising edge period, rising edge to rising edge period and falling edge to falling edge period)			
UART	UART : 2 channels With full-duplex double buffer (8-bit length) Clock asynchronous or clock synchronized transmission (with start and stop bits) can be selected and used. Transmission can be one-to-one (bidirectional communication) or one-to-n (master-slave communication).			
16-bit reload timer	Reload timer : 2 channels Reload mode, single-shot mode or event count mode selectable			
16-bit PPG timer	PPG timer : 3 channels PWM mode or single-shot mode selectable Channel 0 can be worked with multi-functional timer or independently.			
Multi-functional timer (for AC/DC motor control)	16-bit free-running timer with up or up-down mode selection and buffer : 1 channel 16-bit output compare : 6 channels 16-bit input capture : 4 channels 16-bit PPG timer : 1 channel Waveform generator (16-bit timer : 3 channels, 3-phase waveform or dead time)			
8/10-bit A/D converter	8/10-bit resolution (16 channels) Conversion time : Min 3 μ s (24 MHz internal clock, including sampling time)			
8-bit D/A converter	8/10-bit resolution (2 channels)			
DTP/External interrupt	8 independent channels Interrupt factors : Rising edge, falling edge, "L" level or "H" level			
Low-power consumption	Stop mode / Sleep mode / CPU intermittent operation mode			

(Continued)

MB90820 Series

(Continued)

Part number Item	MB90V820	MB90F822	MB90F823	MB90822
Package	PGA-299	LQFP-80 (FPT-80P-M05 : 0.50 mm pitch) LQFP-80 (FPT-80P-M11 : 0.65 mm pitch) QFP-80 (FPT-80P-M06 : 0.80 mm pitch)		
Power supply voltage for operation*1	4.5 V to 5.5 V*1	3.5 V to 5.5 V : Normal operation when A/D converter and D/A converter are not used 4.0 V to 5.5 V : Normal operation when D/A converter is not used 4.5 V to 5.5 V : Normal operation		
Process	CMOS			
Emulator power supply*2	Included	—		

*1 : Assurance for the MB90V820 is operating temperature 0 °C to +25 °C.

*2 : It is setting of Jumper switch (TOOL VCC) when emulator (MB2147-01) is used.
Please refer to the MB2147-01 or MB2147-20 hardware manual (3.3 Emulator-dedicated Power Supply switching) about details.

■ PACKAGE AND CORRESPONDING PRODUCTS

Package	MB90V820	MB90F822	MB90F823	MB90822
PGA299	○	X	X	X
FPT-80P-M05	X	○	○	○
FPT-80P-M11	X	○	○	○
FPT-80P-M06	X	○	○	○

○ : Available
X : Not available

Note: For more information about each package, see "■ PACKAGE DIMENSIONS".

■ DIFFERENCES AMONG PRODUCTS

Memory Size

In evaluation with an evaluation product, note the difference between the evaluation product and the product actually used. The following items must be taken into consideration.

- The MB90V820 does not have an internal ROM, however, operations equivalent to chips with an internal ROM can be evaluated by using a dedicated development tool, enabling selection of ROM size by settings of the development tool.
- In the MB90V820, images from FF8000_H to FFFFFFF_H are mapped to bank 00, and FE0000_H to FF7FFF_H are mapped to bank FE and bank FF only. (This setting can be changed by configuring the development tool.)
- In the MB90822/F822/F823, images from FF8000_H to FFFFFFF_H are mapped to bank 00, and FF0000_H to FF7FFF_H are mapped to bank FF only. In the MB90F823, images from FF8000_H to FFFFFFF_H are mapped to bank 00, and FE0000_H to FF7FFF_H are mapped to bank FE and bank FF only.

PIN ASSIGNMENT

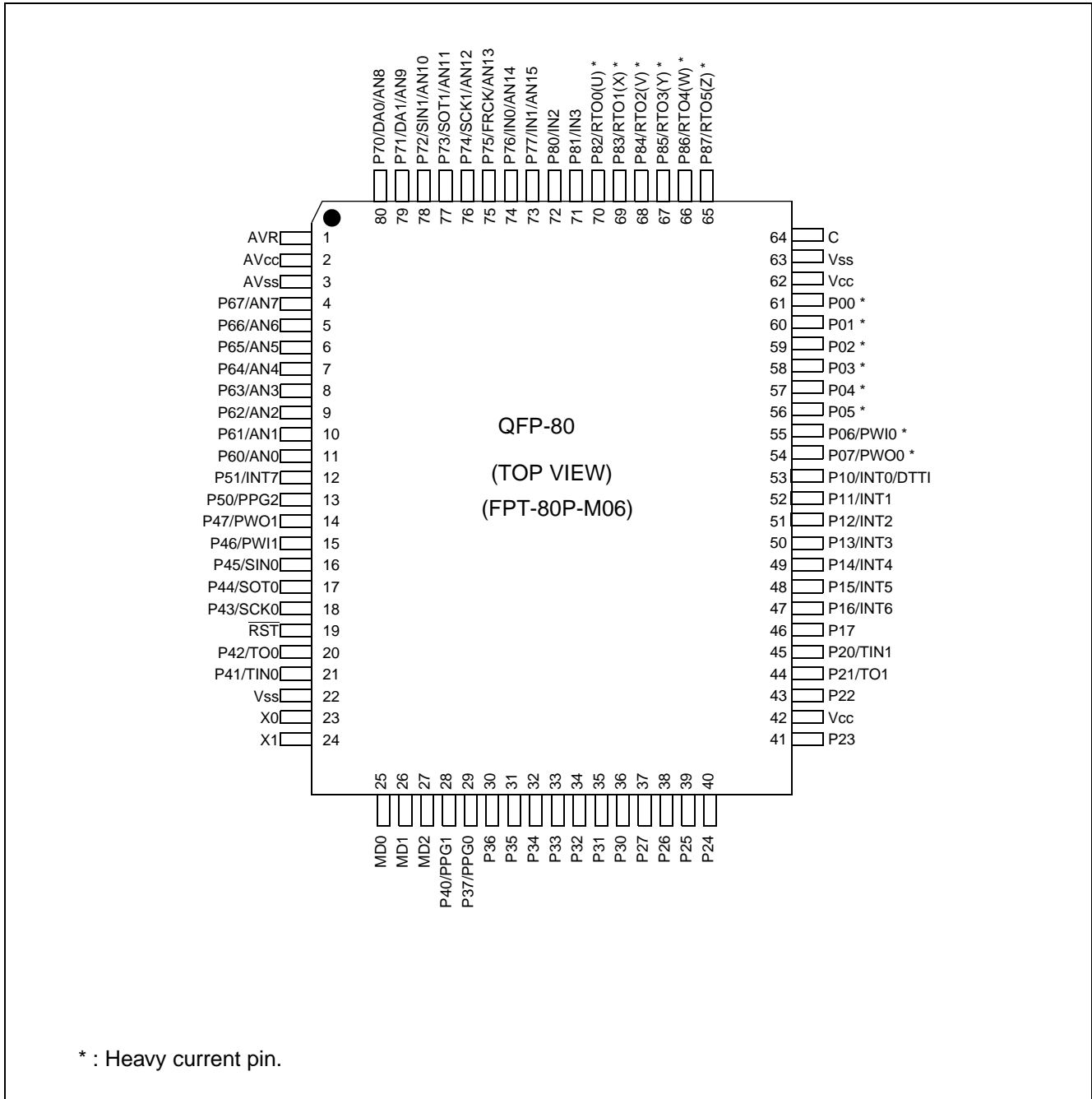

* : Heavy current pin.

(Continued)

MB90820 Series

(Continued)

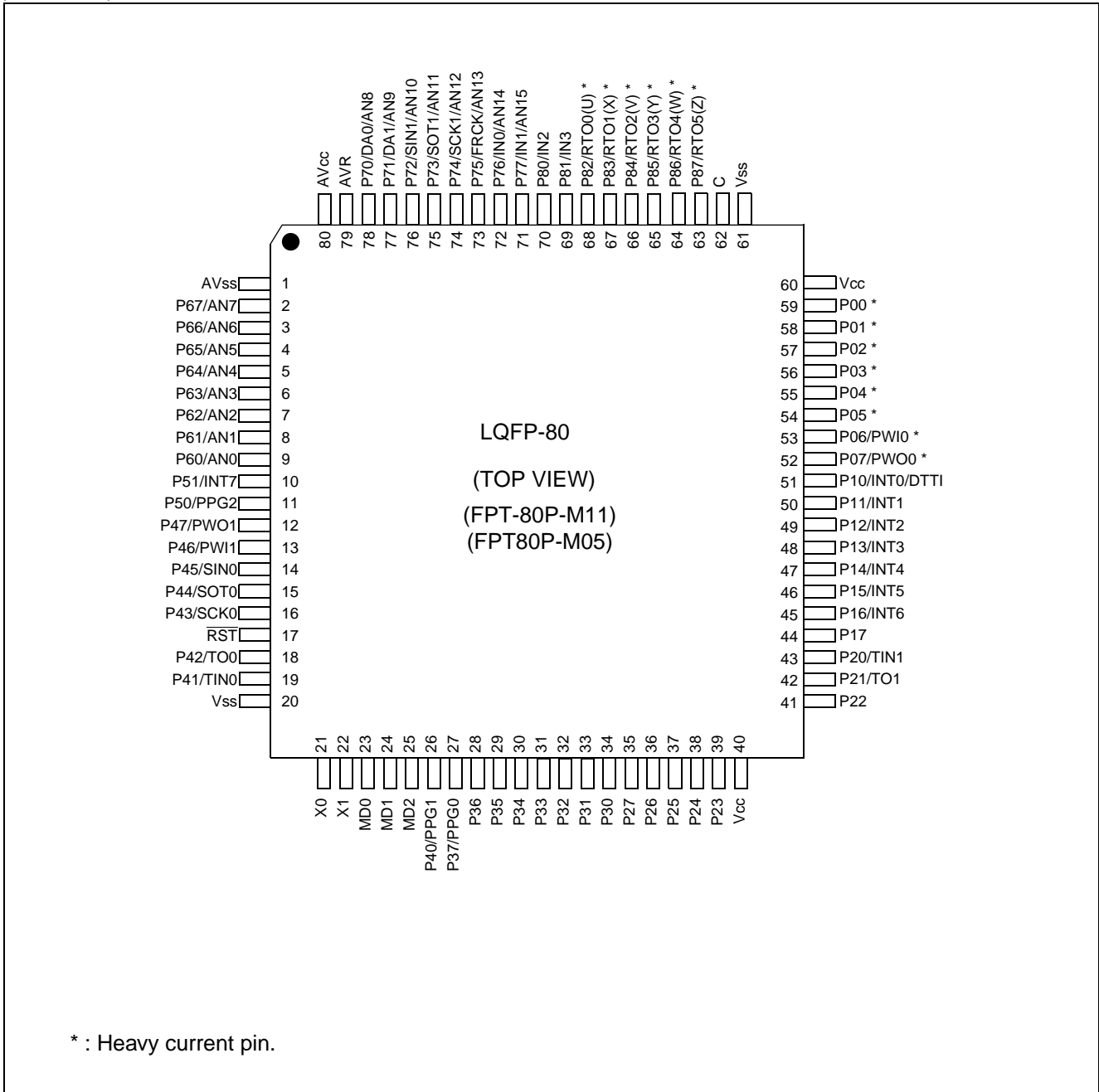

* : Heavy current pin.

■ PIN DESCRIPTION

Pin no.		Pin name	I/O circuit	Pin status during reset	Function
LQFP *1	QFP *2				
21, 22	23, 24	X0,X1	A	Oscillating	Oscillation input pins.
17	19	$\overline{\text{RST}}$	B	Reset input	External reset input pin.
59 to 54	61 to 56	P00 to P05	C	Port input	General-purpose I/O ports.
53	55	P06	C		General-purpose I/O ports.
		PW10			PWC0 signal input pin.
52	54	P07	C		General-purpose I/O ports.
		PW00			PWC0 signal output pin.
51	53	P10	D		General-purpose I/O ports.
		INT0			Can be used as interrupt request input channel 0. Input is enabled when 1 is set in EN0 in standby mode.
		DTTI			RTO0 to 5 pins for fixed-level input. This function is enabled when the waveform generator specifies its input bits.
50 to 45	52 to 47	P11 to P16	D		General-purpose I/O ports.
		INT1 to INT6			Can be used as interrupt request input channel 1 to 6. Input is enabled when 1 is set in EN1 to EN6 in standby mode.
44	46	P17	D		General-purpose I/O ports.
43	45	P20	D		General-purpose I/O ports.
		TIN1			External clock input pin for reload timer1.
42	44	P21	D		General-purpose I/O ports.
		TO1			Event output pin for reload timer1.
41, 39 to 35	43, 41 to 37	P22 to P27	D		General-purpose I/O ports.
34 to 28	36 to 30	P30 to P36	E		General-purpose I/O ports.
27	29	P37	E		General-purpose I/O ports.
		PPG0			Output pins for PPG channel 0. This function is enabled when output of PPG channel 0 is specified.
26	28	P40	F		General-purpose I/O ports.
		PPG1		Output pins for PPG channel 1. This function is enabled when output of PPG channel 1 is specified.	
19	21	P41	F	General-purpose I/O ports.	
		TIN0		External clock input pin for reload timer0.	
18	20	P42	F	General-purpose I/O ports.	
		TO0		Event output pin for reload timer0.	

(Continued)

MB90820 Series

Pin no.		Pin name	I/O circuit	Pin status during reset	Function
LQFP *1	QFP *2				
16	18	P43	F	Port Input	General-purpose I/O ports.
		SCK0			Serial clock I/O pin for UART channel 0. This function is enabled when clock output of UART channel 0 is specified.
15	17	P44	F		General-purpose I/O ports.
		SOT0			Serial data output pin for UART channel 0. This function is enabled when data output of UART channel 0 is specified.
14	16	P45	G		General-purpose I/O ports.
		SIN0			Serial data input pin for UART channel 0. While UART channel 0 is operating for input, the input of this pin is used as required. This pin must not be used for any other input. CMOS input can be selected by user program.
13	15	P46	F		General-purpose I/O ports.
		PWI1			PWC1 signal input pin.
12	14	P47	F		General-purpose I/O ports.
		PWO1			PWC1 signal output pin.
11	13	P50	F		General-purpose I/O ports.
		PPG2			Output pins for PPG channel 2. This function is enabled when output of PPG channel 2 is specified.
10	12	P51	F		General-purpose I/O ports.
		INT7			Usable as interrupt request input channel 7. Input is enabled when 1 is set in EN7 in standby mode.
9 to 2	11 to 4	P60 to P67	H	Analog input	General-purpose I/O ports.
		AN0 to AN7			A/D converter analog input pins. This function is enabled when the analog input is specified (ADER0).
78, 77	80, 79	P70, P71	I		General-purpose I/O ports.
		DA0, DA1			D/A converter analog output pins. This function is enabled when D/A converter is specified.
		AN8, AN9			A/D converter analog input pins. This function is enabled when the analog input is specified (ADER1).

(Continued)

MB90820 Series

Pin no.		Pin name	I/O circuit	Pin status during reset	Function
LQFP *1	QFP *2				
76	78	P72	J	Analog input	General-purpose I/O ports.
		SIN1			Serial data input pin for UART channel 1. While UART channel 1 is operating for input, the input of this pin is used as required. This pin must not be used for any other input. CMOS input can be selected by user program.
		AN10			A/D converter analog input pins. This function is enabled when the analog input is specified (ADER1).
75	77	P73	K		General-purpose I/O ports.
		SOT1			Serial data output pin for UART channel 1. This function is enabled when data output of UART channel 1 is specified.
		AN11			A/D converter analog input pins. This function is enabled when the analog input is specified (ADER1).
74	76	P74	K		General-purpose I/O port.
		SCK1			Serial clock I/O pin for UART channel 1. This function is enabled when clock output of UART channel 1 is specified.
		AN12			A/D converter analog input pins. This function is enabled when the analog input is specified (ADER1).
73	75	P75	K		General-purpose I/O ports.
		FRCK		External clock input pin for free-running timer.	
		AN13		A/D converter analog input pins. This function is enabled when the analog input is specified (ADER1).	
72, 71	74, 73	P76, P77	K	General-purpose I/O ports.	
		IN0, IN1		Trigger input pins for input capture channels 0, 1. When input capture channels 0, 1 are used for input operation, these pins are enabled as required and must not be used for any other input.	
		AN14, AN15		A/D converter analog input pins. This function is enabled when the analog input is specified (ADER1).	

(Continued)

MB90820 Series

(Continued)

Pin no.		Pin name	I/O circuit	Pin status during reset	Function
LQFP *1	QFP *2				
70, 69	72, 71	P80, P81	F	Port input	General-purpose I/O ports.
		IN2, IN3			Trigger input pins for input capture channels 2, 3. When input capture channels 2, 3 are used for input operation, these pins are enabled as required and must not be used for any other input.
68 to 63	70 to 65	P82 to P87	L		General-purpose I/O ports.
		RTO0 to RTO5			Waveform generator output pins. These pins output the waveforms specified at the waveform generator. Output is generated when waveform generator output is enabled.
25	27	MD0	M	Mode input	Input pin for operation mode specification. Connect this pin directly to Vcc or Vss.
24, 23	26, 25	MD1, MD0	N		Input pin for operation mode specification. Connect this pin directly to Vcc or Vss.
80	2	AVcc	–	Power	Vcc power input pin for analog circuits.
79	1	AVR	–		Vref + input pin for the A/D converter. This voltage must not exceed AVcc. Vref - is fixed to AVss.
1	3	AVss	–		Vss power input pin for analog circuits.
20, 61	22, 63	Vss	–	Power	Power (0 V) input pin.
40, 60	42, 62	Vcc	–		Power (5 V) input pin.
62	64	C	–	–	Capacity pin for power stabilization. Please connect to an approximately 0.1 μ F ceramic capacitor.

*1: FPT-80P-M05, FPT-80P-M11

*2: FPT-80P-M06

I/O CIRCUIT TYPE

Classification	Type	Remarks
A		Main clock (main clock crystal oscillator) <ul style="list-style-type: none"> Oscillation feedback resistor : approx. 1 MΩ
B		<ul style="list-style-type: none"> Hysteresis input Pull-up resistor : approx. 50 kΩ
C		<ul style="list-style-type: none"> CMOS output Hysteresis input Selectable pull-up resistor : approx. 50 kΩ $I_{OL} = 12 \text{ mA}$
D		<ul style="list-style-type: none"> CMOS output Hysteresis input Selectable pull-up resistor : approx. 50 kΩ $I_{OL} = 4 \text{ mA}$
E		<ul style="list-style-type: none"> CMOS output CMOS input Selectable pull-up resistor : approx. 50 kΩ $I_{OL} = 4 \text{ mA}$

(Continued)

MB90820 Series

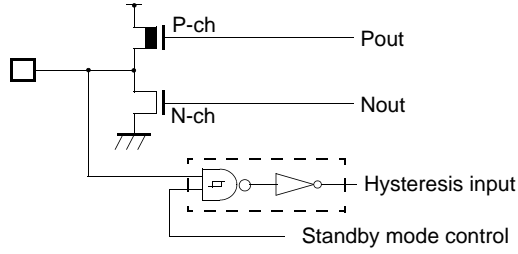
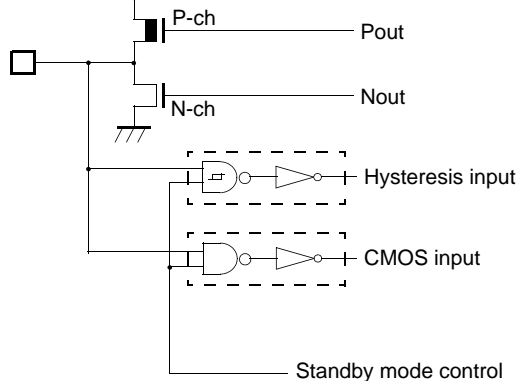
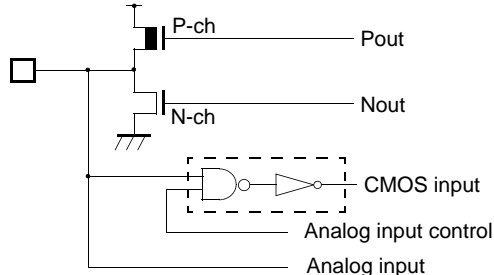
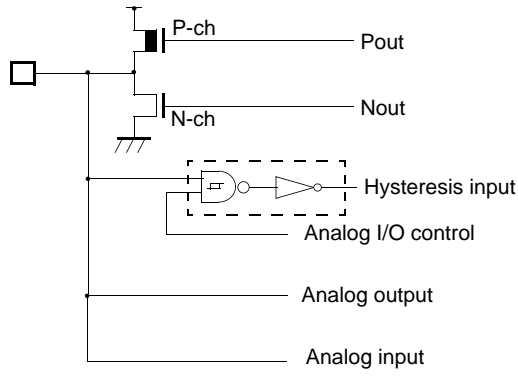
Classification	Type	Remarks
F		<ul style="list-style-type: none"> • CMOS output • Hysteresis input • $I_{OL} = 4 \text{ mA}$
G		<ul style="list-style-type: none"> • CMOS output • Hysteresis input • CMOS input (selectable for UART0 data input pin) • $I_{OL} = 4 \text{ mA}$
H		<ul style="list-style-type: none"> • CMOS output • CMOS input • Analog input • $I_{OL} = 4 \text{ mA}$
I		<ul style="list-style-type: none"> • CMOS output • Hysteresis input • Analog output • Analog input • $I_{OL} = 4 \text{ mA}$

(Continued)

(Continued)

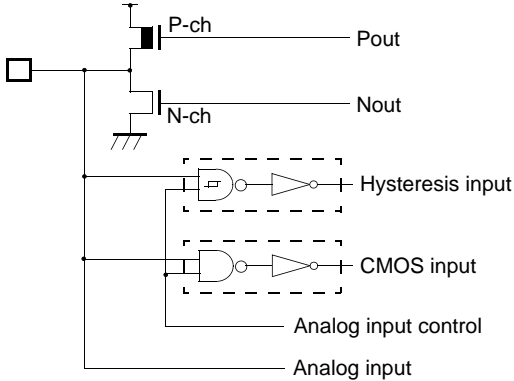
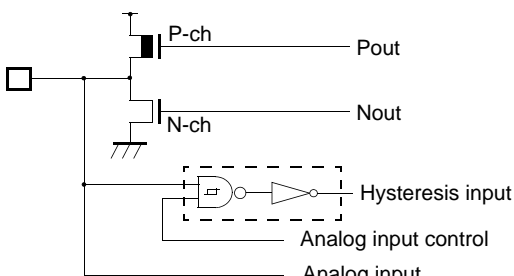
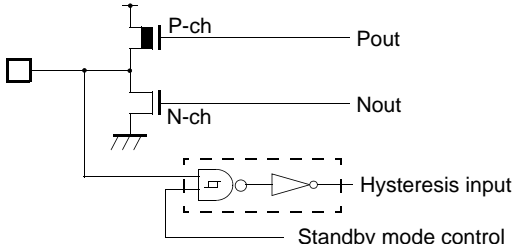
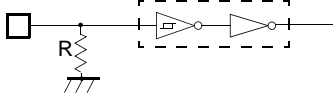
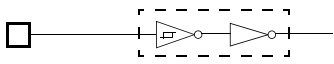
Classification	Type	Remarks
J	 <p>The diagram shows a CMOS output stage with a P-channel MOSFET (P-ch) and an N-channel MOSFET (N-ch). The output is labeled Pout and Nout. Below this, there is a CMOS input stage consisting of two inverters with a feedback loop, labeled Hysteresis input. This stage is controlled by an Analog input control signal. The main Analog input signal is also shown.</p>	<ul style="list-style-type: none"> • CMOS output • Hysteresis input • CMOS input (selectable for UART1 data input pin) • $I_{OL} = 4 \text{ mA}$
K	 <p>The diagram shows a CMOS output stage with P-ch and N-ch transistors, labeled Pout and Nout. Below it is a hysteresis input stage consisting of two inverters with a feedback loop, labeled Hysteresis input. This stage is controlled by an Analog input control signal. The main Analog input signal is also shown.</p>	<ul style="list-style-type: none"> • CMOS output • Hysteresis input • Analog input • $I_{OL} = 4 \text{ mA}$
L	 <p>The diagram shows a CMOS output stage with P-ch and N-ch transistors, labeled Pout and Nout. Below it is a hysteresis input stage consisting of two inverters with a feedback loop, labeled Hysteresis input. This stage is controlled by a Standby mode control signal. The main Analog input signal is also shown.</p>	<ul style="list-style-type: none"> • CMOS output • Hysteresis input • $I_{OL} = 12 \text{ mA}$
M	 <p>The diagram shows a CMOS input stage consisting of two inverters with a feedback loop. A pull-up resistor R is connected to the input of the first inverter. The input is also connected to ground through a resistor.</p>	<p>Mask ROM / evaluation product</p> <ul style="list-style-type: none"> • Hysteresis input • Selectable pull-up resistor : approx. $50 \text{ k}\Omega$ <p>FLASH product</p> <ul style="list-style-type: none"> • CMOS input • No pull-down resistor
N	 <p>The diagram shows a CMOS input stage consisting of two inverters with a feedback loop.</p>	<p>Mask ROM / evaluation product</p> <ul style="list-style-type: none"> • Hysteresis input <p>FLASH product</p> <ul style="list-style-type: none"> • CMOS input

MB90820 Series

■ HANDLING DEVICES

1. Preventing latch-up

CMOS ICs may cause latch-up in the following situations:

- When a voltage higher than V_{CC} or lower than V_{SS} is applied to input or output pins.
- When a voltage exceeding the rating is applied between V_{CC} and V_{SS} .
- When the AV_{CC} power supply is applied before the V_{CC} voltage.

If latch-up occurs, the power supply current increases rapidly, sometimes resulting in thermal breakdown of the device. Use meticulous care not to exceed the rating.

For the same reason, also be careful not to let the analog power-supply voltage exceed the digital power-supply voltage.

2. Handling unused pins

Unused input pins left open may cause abnormal operations, or latch-up leading to permanent damage. Unused input pins should be pulled up or pulled down through at least 2 k Ω resistance.

Unused input/output pins may be left open in output state, but if such pins are in input state they should be handled in the same way as input pins.

If any output pins are unused, set them to open.

3. Use of the external clock

To use an external clock, drive only the X0 pin and leave the X1 pin open (See the illustration below).

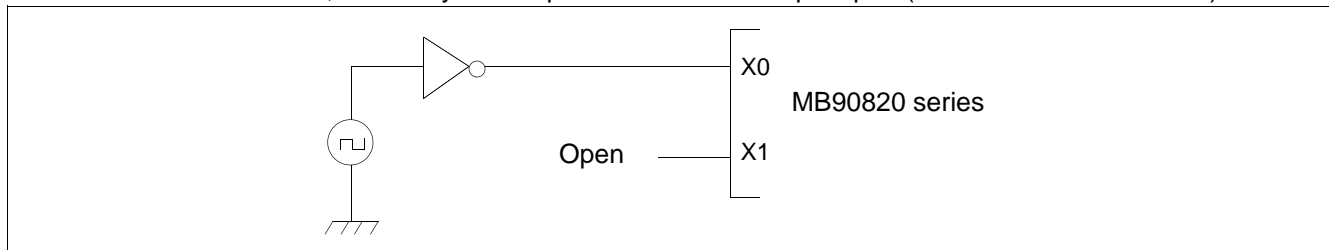

4. Power supply pins (V_{CC}/V_{SS})

In products with multiple V_{CC} or V_{SS} pins, the pins of the same potential are internally connected in the device to avoid abnormal operations including latch-up. However, you must connect the pins to external power supply and a ground lines to lower the electro-magnetic emission level, to prevent abnormal operation of strobe signals caused by the rise in the ground level, and to conform to the total output current rating.

Moreover, connect the current supply source with the V_{CC} and V_{SS} pins of this device at the low impedance.

It is also advisable to connect a ceramic bypass capacitor of approximately 0.1 μF between V_{CC} and V_{SS} near this device.

5. Crystal oscillator circuit

Noise near the X0 and X1 pins may cause the device to malfunction. Design the printed circuit board so that X0, X1, the crystal oscillator (or ceramic oscillator) and the bypass capacitor to ground are located as close to the device as possible.

It is strongly recommended to design the PC board artwork with the X0 and X1 pins surrounded by ground plane because stable operation can be expected with such a layout.

6. Turning-on sequence of power supply to A/D converter and D/A converter

Make sure to turn on the A/D converter and D/A converter power supply (AV_{CC} , AV_{SS} , AVR) and analog inputs (AN0 to AN15) after turning-on the digital power supply (V_{CC}).

Turn-off the digital power after turning off the A/D converter and D/A converter supply and analog inputs. In this case, make sure that the voltage of AVR does not exceed AV_{CC} (turning on/off the analog and digital power supplies simultaneously is acceptable).

7. Connection of unused pins of A/D converter and D/A converter

When the A/D converter and D/A converter are not used, connect the pins as follows: $AV_{CC} = V_{CC}$, $AV_{SS} = AVR = V_{SS}$.

8. N.C. pin

The N.C. (internally connected) pin must be opened for use.

9. Notes on energization

To prevent the internal regulator circuit from malfunctioning, set the voltage rise time during energization at 50 μ s or more.

10. Initialization

In the device, there are internal registers which are initialized only by a power-on reset. To initialize these registers turning on the power again.

11. Return from standby state

If the power supply voltage goes below the standby RAM holding voltage in the standby state, the device may fail to return from the standby state. In this case, reset the device via the external reset pin to return to the normal state.

MB90820 Series

■ BLOCK DIAGRAM

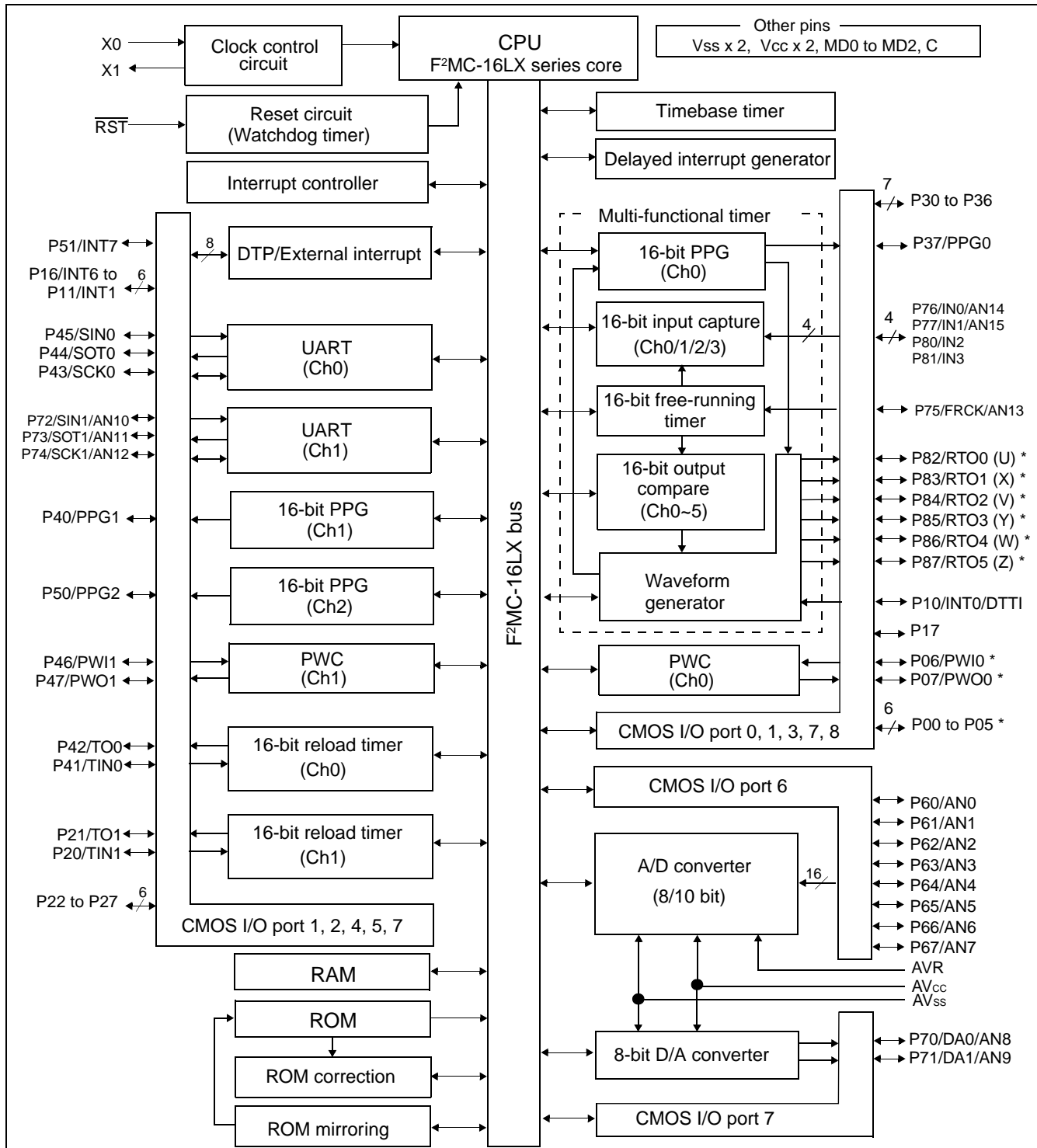

Note : P00 to P07, P10 to P17, P20 to P27 and P30 to P37: With build-in resistors that can be used as input pull-up resistors.

* : Heavy current drive pin.

■ MEMORY MAP

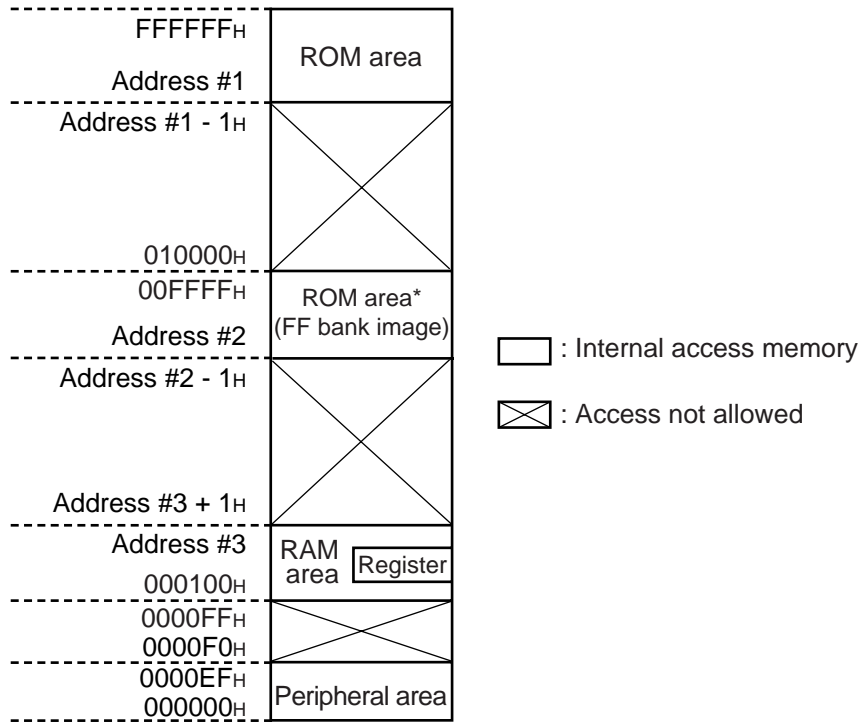

* : In Single chip mode, the mirror function is supported.

Parts no.	Address#1	Address#2	Address#3
MB90822	FF0000 _H	008000 _H	0010FF _H
MB90F822	FF0000 _H	008000 _H	0010FF _H
MB90F823	FE0000 _H	008000 _H	0010FF _H
MB90V820	(FE0000 _H)	008000 _H	0040FF _H

Note: The ROM data of bank FF is reflected to the upper address of bank 00, realizing effective use of the C compiler small model. The lower 16-bit is assigned to the same address, enabling reference of the table on the ROM without stating "far". For example, if an attempt has been made to access 00C000_H, the contents of the ROM at FFC000_H are accessed actually. Since the ROM area of the FF bank exceeds 32K bytes, the whole area cannot be reflected in the image for the 00 bank. The ROM data at FF8000_H to FFFFFFF_H looks, therefore, as if it were the image for 008000_H to 00FFFF_H. Thus, it is recommended that the ROM data table be stored in the area of FF8000_H to FFFFFFF_H.

MB90820 Series

■ F²MC-16LX CPU PROGRAMMING MODEL

- Dedicated registers

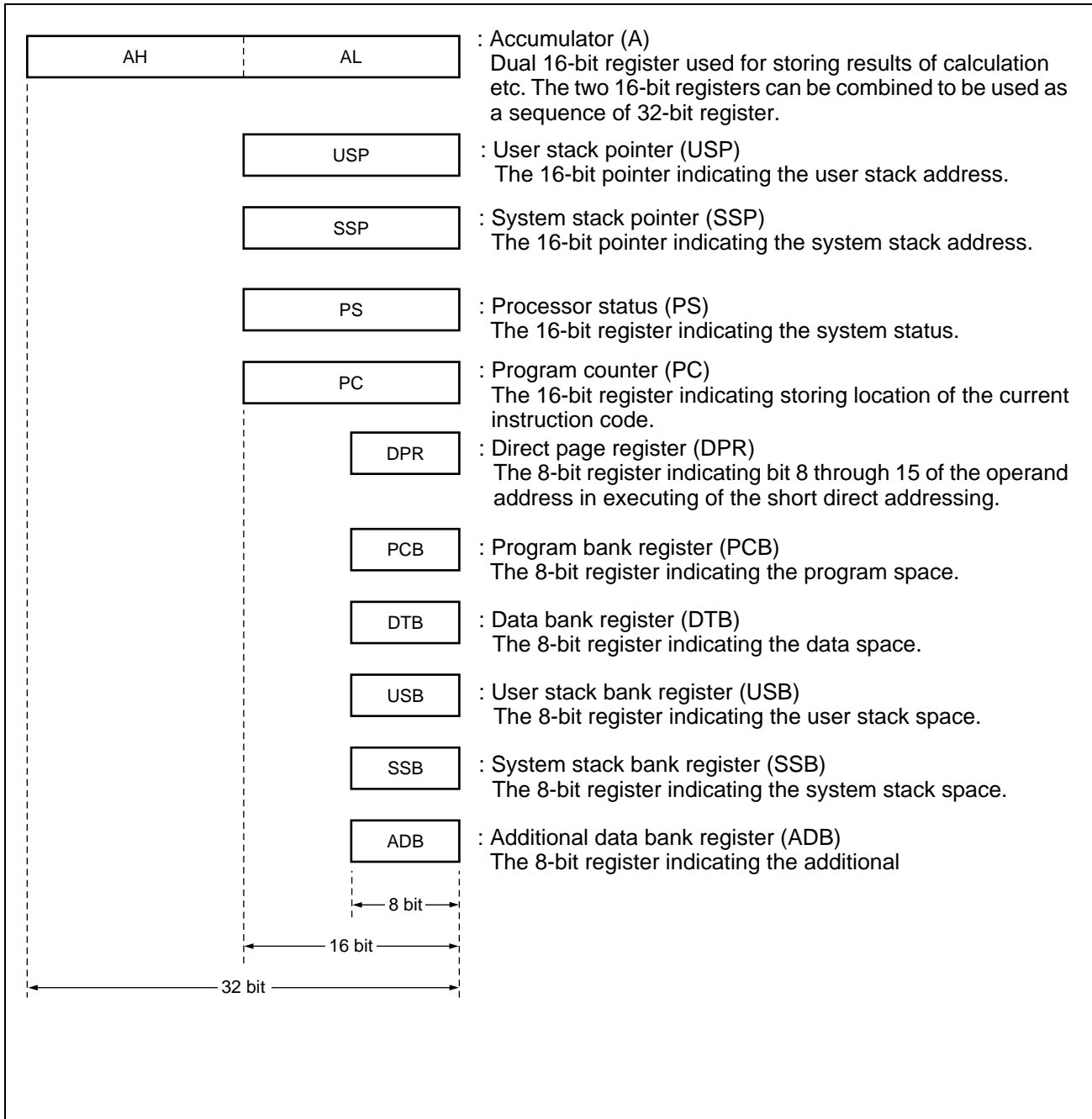

- General-purpose registers

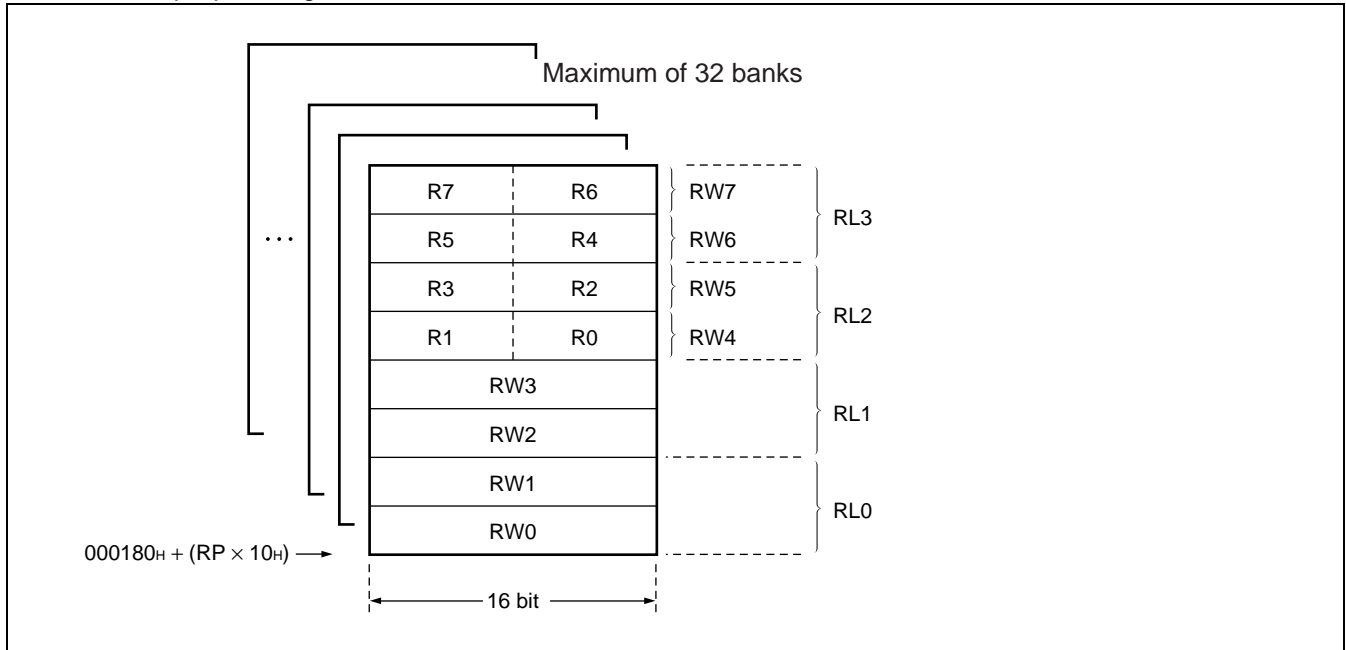

- Processor status (PS)

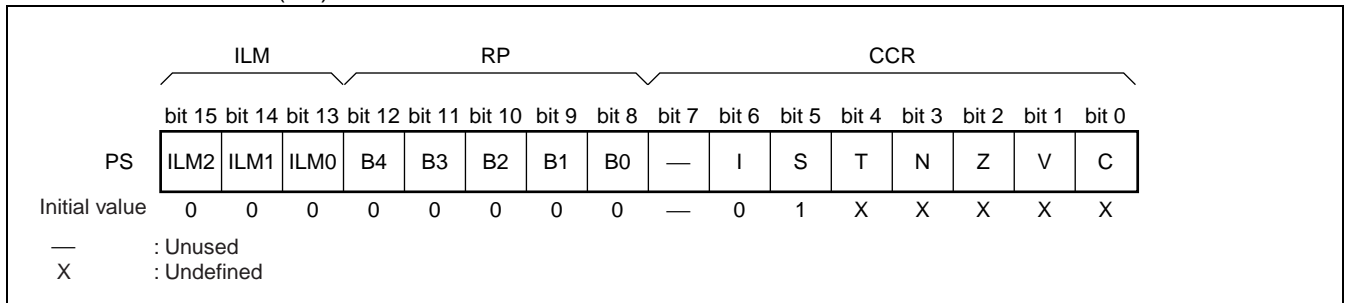

MB90820 Series

■ I/O MAP

Address	Abbreviation	Register	Byte access	Word access	Resource name	Initial value
000000 _H	PDR0	Port 0 data register	R/W	R/W	Port 0	XXXXXXXX _B
000001 _H	PDR1	Port 1 data register	R/W	R/W	Port 1	XXXXXXXX _B
000002 _H	PDR2	Port 2 data register	R/W	R/W	Port 2	XXXXXXXX _B
000003 _H	PDR3	Port 3 data register	R/W	R/W	Port 3	XXXXXXXX _B
000004 _H	PDR4	Port 4 data register	R/W	R/W	Port 4	XXXXXXXX _B
000005 _H	PDR5	Port 5 data register	R/W	R/W	Port 5	XXXXXXXX _B
000006 _H	PDR6	Port 6 data register	R/W	R/W	Port 6	XXXXXXXX _B
000007 _H	PDR7	Port 7 data register	R/W	R/W	Port 7	XXXXXXXX _B
000008 _H	PDR8	Port 8 data register	R/W	R/W	Port 8	XXXXXXXX _B
000009 _H to 00000F _H	Prohibited area					
000010 _H	DDR0	Port 0 data direction register	R/W	R/W	Port 0	00000000 _B
000011 _H	DDR1	Port 1 data direction register	R/W	R/W	Port 1	00000000 _B
000012 _H	DDR2	Port 2 data direction register	R/W	R/W	Port 2	00000000 _B
000013 _H	DDR3	Port 3 data direction register	R/W	R/W	Port 3	00000000 _B
000014 _H	DDR4	Port 4 data direction register	R/W	R/W	Port 4	00000000 _B
000015 _H	DDR5	Port 5 data direction register	R/W	R/W	Port 5	XXXXXXXX00 _B
000016 _H	DDR6	Port 6 data direction register	R/W	R/W	Port 6	00000000 _B
000017 _H	DDR7	Port 7 data direction register	R/W	R/W	Port 7	00000000 _B
000018 _H	DDR8	Port 8 data direction register	R/W	R/W	Port 8	00000000 _B
000019 _H to 00001F _H	Prohibited area					
000020 _H	SMR0	Serial mode register 0	R/W	R/W	UART0	00000000 _B
000021 _H	SCR0	Serial control register 0	R/W	R/W		00000100 _B
000022 _H	SIDR0 / SODR0	Serial input data register 0 / Serial output data register 0	R/W	R/W		XXXXXXXX _B
000023 _H	SSR0	Serial status register 0	R/W	R/W		00001000 _B
000024 _H	SMR1	Serial mode register 1	R/W	R/W	UART1	00000000 _B
000025 _H	SCR1	Serial control register 1	R/W	R/W		00000100 _B
000026 _H	SIDR1 / SODR1	Serial input data register 1 / Serial output data register 1	R/W	R/W		XXXXXXXX _B
000027 _H	SSR1	Serial status register 1	R/W	R/W		00001000 _B
000028 _H	PWCSL1	PWC control status register CH1	R/W	R/W	PWC timer (CH1)	00000000 _B
000029 _H	PWCSH1		R/W	R/W		00000000 _B
00002A _H	PWC1	PWC data buffer register CH1	—	R/W		XXXXXXXX _B
00002B _H			XXXXXXXX _B			
00002C _H	DIV1	Divide ratio control register CH1	R/W	R/W		XXXXXXXX00 _B

(Continued)

MB90820 Series

Address	Abbreviation	Register	Byte access	Word access	Resource name	Initial value
00002D _H , 00002E _H	Prohibited area					
00002F _H	PCKCR	PLL clock control register	W	W	PLL	XXXX0000 _B
000030 _H	ENIR	DTP / Interrupt enable register	R/W	R/W	DTP/ external interrupt	00000000 _B
000031 _H	EIRR	DTP / Interrupt cause register	R/W	R/W		XXXXXXXX _B
000032 _H	ELVRL	Request level setting register (lower byte)	R/W	R/W		00000000 _B
000033 _H	ELVRH	Request level setting register (higher byte)	R/W	R/W		00000000 _B
000034 _H	Prohibited area					
000035 _H	CDCR0	Clock division control register CH0	R/W	R/W	Communication prescaler 0	00XXX000 _B
000036 _H	Prohibited area					
000037 _H	CDCR1	Clock division control register CH1	R/W	R/W	Communication prescaler 1	00XXX000 _B
000038 _H	PDCR0	PPG0 down counter register	—	R	16-bit PPG timer (CH0)	11111111 _B
000039 _H						11111111 _B
00003A _H	PCSR0	PPG0 period setting register	—	W		XXXXXXXX _B
00003B _H						XXXXXXXX _B
00003C _H	PDUT0	PPG0 duty setting register	—	W		XXXXXXXX _B
00003D _H						XXXXXXXX _B
00003E _H	PCNTL0	PPG0 control status register	R/W	R/W		XX000000 _B
00003F _H	PCNTH0		R/W	R/W		00000000 _B
000040 _H	PDCR1	PPG1 down counter register	—	R	16-bit PPG timer (CH1)	11111111 _B
000041 _H						11111111 _B
000042 _H	PCSR1	PPG1 period setting register	—	W		XXXXXXXX _B
000043 _H						XXXXXXXX _B
000044 _H	PDUT1	PPG1 duty setting register	—	W		XXXXXXXX _B
000045 _H						XXXXXXXX _B
000046 _H	PCNTL1	PPG1 control status register	R/W	R/W		XX000000 _B
000047 _H	PCNTH1		R/W	R/W		00000000 _B
000048 _H	PDCR2	PPG2 down counter register	—	R	16-bit PPG timer (CH2)	11111111 _B
000049 _H						11111111 _B
00004A _H	PCSR2	PPG2 period setting register	—	W		XXXXXXXX _B
00004B _H						XXXXXXXX _B
00004C _H	PDUT2	PPG2 duty setting register	—	W		XXXXXXXX _B
00004D _H						XXXXXXXX _B
00004E _H	PCNTL2	PPG2 control status register	R/W	R/W		XX000000 _B
00004F _H	PCNTH2		R/W	R/W		00000000 _B

(Continued)

MB90820 Series

Address	Abbreviation	Register	Byte access	Word access	Resource name	Initial value
000050 _H	TMRR0	16-bit timer register 0	—	R/W	Waveform generator	XXXXXXXX _B
000051 _H						XXXXXXXX _B
000052 _H	TMRR1	16-bit timer register 1	—	R/W		XXXXXXXX _B
000053 _H						XXXXXXXX _B
000054 _H	TMRR2	16-bit timer register 2	—	R/W		XXXXXXXX _B
000055 _H						XXXXXXXX _B
000056 _H	DTCR0	16-bit timer control register 0	R/W	R/W		00000000 _B
000057 _H	DTCR1	16-bit timer control register 1	R/W	R/W		00000000 _B
000058 _H	DTCR2	16-bit timer control register 2	R/W	R/W		00000000 _B
000059 _H	SIGCR	Waveform control register	R/W	R/W	00000000 _B	
00005A _H	CPCLRB / CPCLR	Compare clear buffer register / Compare clear register (lower)	—	R/W	16-bit free-running timer	11111111 _B
00005B _H						11111111 _B
00005C _H	TCDT	Timer register (lower)	—	R/W		00000000 _B
00005D _H						00000000 _B
00005E _H	TCCSL	Timer control status register (lower)	R/W	R/W	16-bit free-running timer	00000000 _B
00005F _H	TCCSH	Timer control status register (upper)	R/W	R/W		X0000000 _B
000060 _H	IPCP0	Input capture data register CH0	—	R	16-bit input capture (CH0 to CH3)	XXXXXXXX _B
000061 _H						XXXXXXXX _B
000062 _H	IPCP1	Input capture data register CH1	—	R		XXXXXXXX _B
000063 _H						XXXXXXXX _B
000064 _H	IPCP2	Input capture data register CH2	—	R		XXXXXXXX _B
000065 _H						XXXXXXXX _B
000066 _H	IPCP3	Input capture data register CH3	—	R		XXXXXXXX _B
000067 _H						XXXXXXXX _B
000068 _H	PICSL01	Input capture control status register (ch0,1) (lower)	R/W	R/W		00000000 _B
000069 _H	PICSH01	PPG output control / Input capture control status register (ch0,1) (upper)	R/W	R/W		00000000 _B
00006A _H	ICSL23	Input capture control status register (ch2, 3) (lower)	R/W	R/W	00000000 _B	
00006B _H	ICSH23	Input capture control status register (ch2, 3) (upper)	R	R	XXXXXXXX00 _B	
00006C _H to 00006E _H	Prohibited area					

(Continued)

MB90820 Series

Address	Abbreviation	Register	Byte access	Word access	Resource name	Initial value	
00006FH	ROMM	ROM mirroring function selection register	W	W	ROM mirroring function	XXXXXXXX1 _B	
000070H	OCCPB0 / OCCP0	Output compare buffer register / Output compare register 0	—	R/W	Output compare (CH0 to CH5)	XXXXXXXX _B	
000071H						XXXXXXXX _B	
000072H	OCCPB1 / OCCP1	Output compare buffer register / Output compare register 1	—	R/W		XXXXXXXX _B	
000073H						XXXXXXXX _B	
000074H	OCCPB2 / OCCP2	Output compare buffer register / Output compare register 2	—	R/W		XXXXXXXX _B	
000075H						XXXXXXXX _B	
000076H	OCCPB3 / OCCP3	Output compare buffer register / Output compare register 3	—	R/W		XXXXXXXX _B	
000077H						XXXXXXXX _B	
000078H	OCCPB4 / OCCP4	Output compare buffer register / Output compare register 4	—	R/W		XXXXXXXX _B	
000079H						XXXXXXXX _B	
00007AH	OCCPB5 / OCCP5	Output compare buffer register / Output compare register 5	—	R/W		XXXXXXXX _B	
00007BH						XXXXXXXX _B	
00007CH	OCS0	Compare control register CH0	R/W	R/W			00000000 _B
00007DH	OCS1	Compare control register CH1	R/W	R/W			X0000000 _B
00007EH	OCS2	Compare control register CH2	R/W	R/W			00000000 _B
00007FH	OCS3	Compare control register CH3	R/W	R/W		X0000000 _B	
000080H	OCS4	Compare control register CH4	R/W	R/W		00000000 _B	
000081H	OCS5	Compare control register CH5	R/W	R/W		X0000000 _B	
000082H	TMCSRL0	Timer control status register CH0 (lower)	R/W	R/W	16-bit reload timer (CH0)	00000000 _B	
000083H	TMCSRH0	Timer control status register CH0 (upper)	R/W	R/W		XXXX0000 _B	
000084H	TMR0 / TMRD0	16 bit timer register CH0 / 16-bit reload register CH0	—	R/W		XXXXXXXX _B	
000085H					XXXXXXXX _B		
000086H	TMCSRL1	Timer control status register CH1 (lower)	R/W	R/W	16-bit reload timer (CH1)	00000000 _B	
000087H	TMCSRH1	Timer control status register CH1 (upper)	R/W	R/W		XXXX0000 _B	
000088H	TMR1 / TMRD1	16 bit timer register CH1 / 16-bit reload register CH1	—	R/W		XXXXXXXX _B	
000089H					XXXXXXXX _B		
00008AH, 00008BH	Prohibited area						
00008CH	RDR0	Port 0 pull-up resistor setting register	R/W	R/W	Port 0	00000000 _B	
00008DH	RDR1	Port 1 pull-up resistor setting register	R/W	R/W	Port 1	00000000 _B	

(Continued)

MB90820 Series

Address	Abbreviation	Register	Byte access	Word access	Resource name	Initial value
00008E _H	RDR2	Port 2 pull-up resistor setting register	R/W	R/W	Port 2	00000000 _B
00008F _H	RDR3	Port 3 pull-up resistor setting register	R/W	R/W	Port 3	00000000 _B
000090 _H to 00009D _H	Prohibited area					
00009E _H	PACSR	Program address detection control status register	R/W	R/W	Address match detection	00000000 _B
00009F _H	DIRR	Delayed interrupt cause / clear register	R/W	R/W	Delayed interrupt	XXXXXXXX0 _B
0000A0 _H	LPMCR	Low-power consumption mode control register	R/W	R/W	Low-power consumption control register	00011000 _B
0000A1 _H	CKSCR	Clock selection register	R/W	R/W		11111100 _B
0000A2 _H to 0000A7 _H	Prohibited area					
0000A8 _H	WDTC	Watchdog timer control register	R/W	R/W	Watchdog timer	XXXXX111 _B
0000A9 _H	TBTC	Timebase timer control register	R/W	R/W	Timebase timer	1XX00100 _B
0000AA _H to 0000AD _H	Prohibited area					
0000AE _H	FMCS	Flash memory control status register	R/W	R/W	Flash memory interface circuit	000X0000 _B
0000AF _H	Prohibited area					
0000B0 _H	ICR00	Interrupt control register 00	R/W	R/W	Interrupt controller	00000111 _B
0000B1 _H	ICR01	Interrupt control register 01	R/W	R/W		00000111 _B
0000B2 _H	ICR02	Interrupt control register 02	R/W	R/W		00000111 _B
0000B3 _H	ICR03	Interrupt control register 03	R/W	R/W		00000111 _B
0000B4 _H	ICR04	Interrupt control register 04	R/W	R/W		00000111 _B
0000B5 _H	ICR05	Interrupt control register 05	R/W	R/W		00000111 _B
0000B6 _H	ICR06	Interrupt control register 06	R/W	R/W		00000111 _B
0000B7 _H	ICR07	Interrupt control register 07	R/W	R/W		00000111 _B
0000B8 _H	ICR08	Interrupt control register 08	R/W	R/W		00000111 _B
0000B9 _H	ICR09	Interrupt control register 09	R/W	R/W		00000111 _B
0000BA _H	ICR10	Interrupt control register 10	R/W	R/W		00000111 _B
0000BB _H	ICR11	Interrupt control register 11	R/W	R/W		00000111 _B
0000BC _H	ICR12	Interrupt control register 12	R/W	R/W		00000111 _B
0000BD _H	ICR13	Interrupt control register 13	R/W	R/W		00000111 _B
0000BE _H	ICR14	Interrupt control register 14	R/W	R/W		00000111 _B
0000BF _H	ICR15	Interrupt control register 15	R/W	R/W		00000111 _B

(Continued)

(Continued)

Address	Abbreviation	Register	Byte access	Word access	Resource name	Initial value
0000C0 _H	PWCSL0	PWC control status register CH0	R/W	R/W	PWC timer (CH0)	00000000 _B
0000C1 _H	PWCSH0		R/W	R/W		00000000 _B
0000C2 _H	PWC0	PWC data buffer register CH0	—	R/W		XXXXXXXX _B
0000C3 _H						XXXXXXXX _B
0000C4 _H	DIV0	Divide ratio control register CH0	R/W	R/W		XXXXXX00 _B
0000C5 _H	ADER0	A/D input enable register 0	R/W	R/W	Port 6, A/D	11111111 _B
0000C6 _H	ADCS0	A/D control status register 0	R/W	R/W	8/10-bit A/D converter	000XXXX0 _B
0000C7 _H	ADCS1	A/D control status register 1	R/W	R/W		0000000X _B
0000C8 _H	ADCR0	A/D data register 0	R	R		00000000 _B
0000C9 _H	ADCR1	A/D data register 1	R/W	R/W		XXXXXXXX00 _B
0000CA _H	ADSR0	A/D setting register 0	R/W	R/W		00000000 _B
0000CB _H	ADSR1	A/D setting register 1	R/W	R/W		00000000 _B
0000CC _H	DAT0	D/A data register 0	R/W	R/W	8-bit D/A converter	XXXXXXXX _B
0000CD _H	DAT1	D/A data register 1	R/W	R/W		XXXXXXXX _B
0000CE _H	DACR0	D/A control register 0	R/W	R/W		XXXXXXXX0 _B
0000CF _H	DACR1	D/A control register 1	R/W	R/W		XXXXXXXX0 _B
0000D0 _H	ADER1	A/D input enable register 1	R/W	R/W	Port 7, A/D	11111111 _B
0000D1 _H to 0000EF _H	Prohibited area					
0000F0 _H to 0000FF _H	External area					
001FF0 _H	PADRL0	Program address detection register 0 (lower)	R/W	R/W	Address match detection	XXXXXXXX _B
001FF1 _H	PADRM0	Program address detection register 0 (middle)	R/W	R/W		XXXXXXXX _B
001FF2 _H	PADRH0	Program address detection register 0 (higher)	R/W	R/W		XXXXXXXX _B
001FF3 _H	PADRL1	Program address detection register 1 (lower)	R/W	R/W		XXXXXXXX _B
001FF4 _H	PADRM1	Program address detection register 1 (middle)	R/W	R/W		XXXXXXXX _B
001FF5 _H	PADRH1	Program address detection register 1 (higher)	R/W	R/W		XXXXXXXX _B

- Meaning of abbreviations used for reading and writing
 R/W: Read and write enabled
 R : Read-only
 W : Write-only
- Explanation of initial values
 0 : The bit is initialized to 0.
 1 : The bit is initialized to 1.
 X : The initial value of the bit is undefined.

MB90820 Series

■ INTERRUPT FACTORS, INTERRUPT VECTORS, INTERRUPT CONTROL REGISTER

Interrupt cause	EI ² OS support	Interrupt vector		Interrupt control register		Priority	
		Number	Address	ICR	Address		
Reset	×	#08	08 _H	FFFD _C _H	—	—	<div style="display: flex; align-items: center;"> High ↑ <div style="flex-grow: 1; border-left: 1px solid black; border-right: 1px solid black; position: relative; margin: 0 5px;"> <div style="position: absolute; top: -5px; left: -5px; right: -5px; height: 100%;"></div> </div> ↓ Low </div>
INT9 instruction	×	#09	09 _H	FFFD ₈ _H	—	—	
Exception processing	×	#10	0A _H	FFFD ₄ _H	—	—	
A/D converter conversion termination	○	#11	0B _H	FFFD ₀ _H	ICR00	0000B ₀ _H	
Output compare channel 0 match	○	#12	0C _H	FFF _F C _C _H			
End of measurement by PWC timer 0 / PWC timer 0 overflow	○	#13	0D _H	FFF _F C ₈ _H	ICR01	0000B ₁ _H	
16-bit PPG timer 0	○	#14	0E _H	FFF _F C ₄ _H			
Output compare channel 1 match	○	#15	0F _H	FFF _F C ₀ _H	ICR02	0000B ₂ _H	
16-bit PPG timer 1	○	#16	10 _H	FFF _F B _C _H			
Output compare channel 2 match	○	#17	11 _H	FFF _F B ₈ _H	ICR03	0000B ₃ _H	
16-bit reload timer 1 underflow	○	#18	12 _H	FFF _F B ₄ _H			
Output compare channel 3 match	○	#19	13 _H	FFF _F B ₀ _H	ICR04	0000B ₄ _H	
DTP/ext. interrupt channels 0/1 detection	○	#20	14 _H	FFF _F A _C _H			
DTTI	△						
Output compare channel 4 match	○	#21	15 _H	FFF _F A ₈ _H	ICR05	0000B ₅ _H	
DTP/ext. interrupt channels 2/3 detection	○	#22	16 _H	FFF _F A ₄ _H			
Output compare channel 5 match	○	#23	17 _H	FFF _F A ₀ _H	ICR06	0000B ₆ _H	
End of measurement by PWC timer 1 / PWC timer 1 overflow	○	#24	18 _H	FFF _F 9 _C _H			
DTP/ext. interrupt channels 4 detection	○	#25	19 _H	FFF _F 9 ₈ _H	ICR07	0000B ₇ _H	
DTP/ext. interrupt channels 5 detection	○	#26	1A _H	FFF _F 9 ₄ _H			
DTP/ext. interrupt channels 6 detection	○	#27	1B _H	FFF _F 9 ₀ _H	ICR08	0000B ₈ _H	
DTP/ext. interrupt channels 7 detection	○	#28	1C _H	FFF _F 8 _C _H			
Waveform generator 16-bit timers 0/1/2 underflow	△	#29	1D _H	FFF _F 8 ₈ _H	ICR09	0000B ₉ _H	
16-bit reload timer 0 underflow	○	#30	1E _H	FFF _F 8 ₄ _H			
16-bit free-running timer zero detect	△	#31	1F _H	FFF _F 8 ₀ _H	ICR10	0000B _A _H	
16-bit PPG timer 2	○	#32	20 _H	FFF _F 7 _C _H			
Input capture channels 0/1	○	#33	21 _H	FFF _F 7 ₈ _H	ICR11	0000B _B _H	
16-bit free-running timer compare clear	△	#34	22 _H	FFF _F 7 ₄ _H			
Input capture channels 2/3	○	#35	23 _H	FFF _F 7 ₀ _H	ICR12	0000B _C _H	
Timebase timer	△	#36	24 _H	FFF _F 6 _C _H			
UART1 receive	◎	#37	25 _H	FFF _F 6 ₈ _H	ICR13	0000B _D _H	
UART1 send	△	#38	26 _H	FFF _F 6 ₄ _H			
UART0 receive	◎	#39	27 _H	FFF _F 6 ₀ _H	ICR14	0000B _E _H	
UART0 send	△	#40	28 _H	FFF _F 5 _C _H			
Flash memory status	△	#41	29 _H	FFF _F 5 ₈ _H	ICR15	0000B _F _H	
Delayed interrupt generator module	△	#42	2A _H	FFF _F 5 ₄ _H			

◎ : Can be used and support the EI²OS stop request.

○ : Can be used and interrupt request flag is cleared by EI²OS interrupt clear signal.

×

△ : Usable when an interrupt cause that shares the ICR is not used.

■ PERIPHERAL RESOURCES

1. Low-power Consumption Control Circuit

The MB90820 series has the following CPU operating mode configured by selection of an operating clock and clock operation control.

- Clock mode

PLL clock mode : A PLL clock that is a multiple of the oscillation clock (HCLK) frequency is used to operate the CPU and peripheral functions.

Main clock mode : The main clock, with a frequency one-half that of the oscillation clock (HCLK), is used to operate the CPU and peripheral functions. In main clock mode, the PLL divide circuit is inactive.

- CPU intermittent operation mode

CPU intermittent operation mode causes the CPU to operate intermittently, while high-speed clock pulses are supplied to peripheral functions, reducing power consumption. In CPU intermittent operation mode, clock pulses are supplied intermittently to the CPU when it is accessing a register, internal memory, a peripheral function, or an external unit.

- Standby mode

In standby mode, the low power consumption control circuit reduces power consumption by stopping;

- The supply of the clock to CPU (sleep mode)
- CPU and peripheral functions (timebase timer mode)
- The oscillation clock itself (stop mode)

- PLL sleep mode

PLL sleep mode is activated to stop the CPU operating clock when the microcontroller enters PLL clock mode; other components continue to operate on the PLL clock.

- Main sleep mode

Main sleep mode is activated to stop the CPU operating clock when the microcontroller enters main clock mode; other components continue to operate on the main clock.

- PLL timebase timer mode

PLL timebase timer mode causes microcontroller operation, with the exception of the oscillation clock, PLL clock and timebase timer, to stop. All functions other than the timebase timer are deactivated.

- Main timebase timer mode

Main timebase timer mode causes microcontroller operation, with the exception of the oscillation clock, main clock and the timebase timer, to stop. All functions other than the timebase timer are deactivated.

- Stop mode

Stop mode causes the source oscillation to stop. All functions are deactivated.

MB90820 Series

(1) Register configuration

Clock Selection Register

	15	14	13	12	11	10	9	8	Bit
Address: 00000A1 _H	Reserved	MCM	WS1	WS0	Reserved	MCS	CS1	CS0	CKSCR
Read/write ⇨	R/W	R	R/W	R/W	R/W	R/W	R/W	R/W	
Initial value ⇨	1	1	1	1	1	1	0	0	

PLL Clock Control Register

	15	14	13	12	11	10	9	8	Bit
Address: 000002F _H	—	—	—	—	Reserved	Reserved	Reserved	CS2	PCKCR
Read/write ⇨	—	—	—	—	W	W	W	W	
Initial value ⇨	X	X	X	X	0	0	0	0	

Low-power Consumption Mode Control Register

	7	6	5	4	3	2	1	0	Bit
Address: 0000A0 _H	STP	SLP	SPL	RST	TMD	CG1	CG0	Reserved	LPMCR
Read/write ⇨	W	W	R/W	W	W	R/W	R/W	R/W	
Initial value ⇨	0	0	0	1	1	0	0	0	

(2) Block diagram

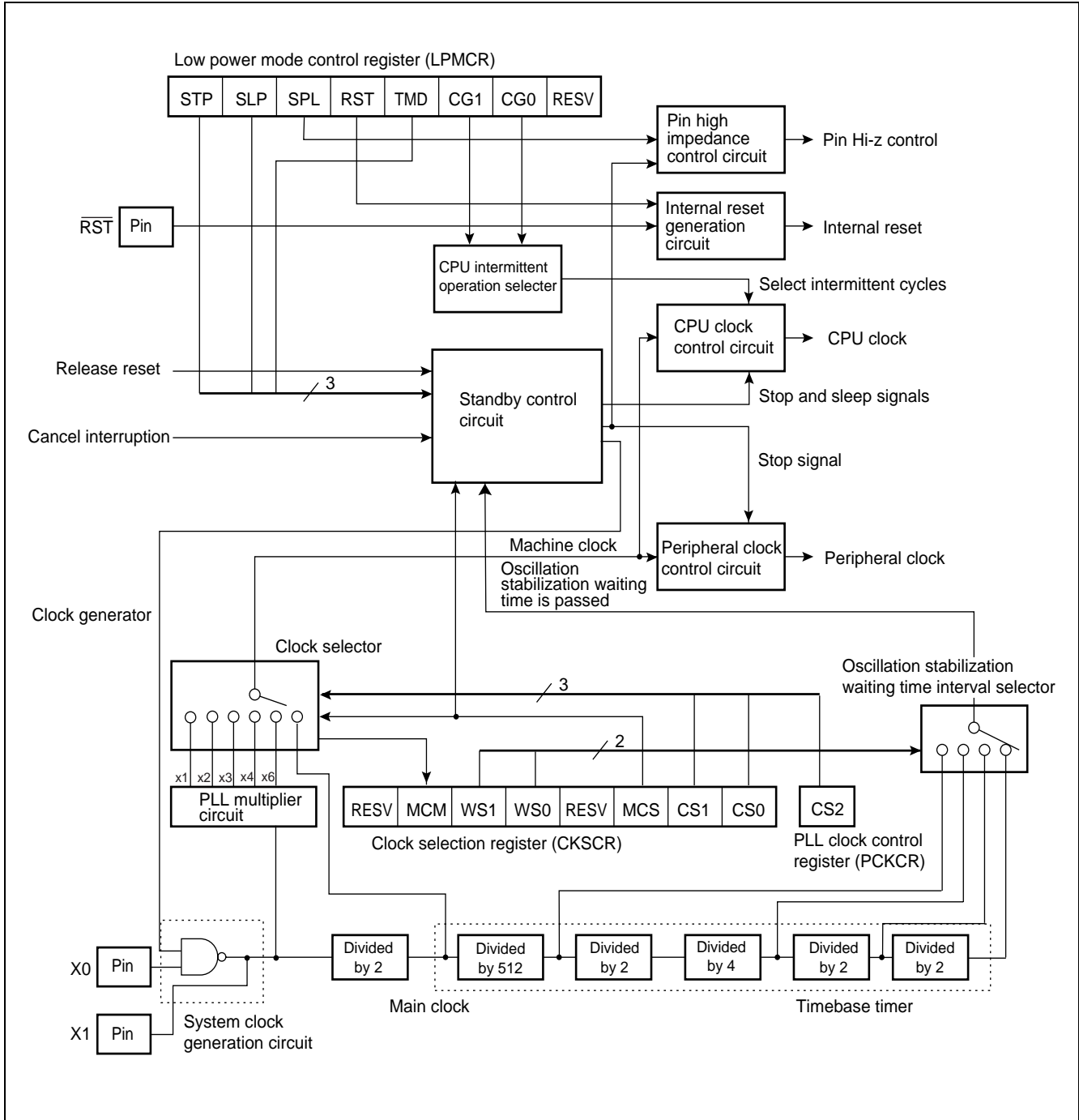

MB90820 Series

2. I/O Ports

(1) Outline of I/O ports

Each I/O port outputs data from CPU to I/O pins or inputs signals from I/O pins to CPU through port data register (PDR). Direction of the data flow (input or output) for each I/O pin can be designated in bit unit by port data direction register (DDR). The function of each port and the resource I/O multiplexed with it are described below:

- Port 0 : General-purpose I/O port/resource (PWC)
- Port 1 : General-purpose I/O port/resources (DTP / Multi-functional timer)
- Port 2 : General-purpose I/O port/resource (16-bit reload timer)
- Port 3 : General-purpose I/O port/resource (16-bit PPG timer)
- Port 4 : General-purpose I/O port/resources (16-bit PPG timer / 16-bit reload timer / UART / PWC)
- Port 5 : General-purpose I/O port/resources (16-bit PPG timer / DTP)
- Port 6 : General-purpose I/O port/resource (8/10-bit A/D converter)
- Port 7 : General-purpose I/O port/resources (8/10-bit A/D converter / 8-bit D/A converter / UART / 16-bit free-running timer / 16-bit input capture)
- Port 8 : General-purpose I/O port/resources (16-bit input capture / Multi-functional timer)

(2) Register configuration

Register	Read/Write	Address	Initial value
Port 0 data register (PDR0)	R/W	000000 _H	XXXXXXXX _B
Port 1 data register (PDR1)	R/W	000001 _H	XXXXXXXX _B
Port 2 data register (PDR2)	R/W	000002 _H	XXXXXXXX _B
Port 3 data register (PDR3)	R/W	000003 _H	XXXXXXXX _B
Port 4 data register (PDR4)	R/W	000004 _H	XXXXXXXX _B
Port 5 data register (PDR5)	R/W	000005 _H	XXXXXXXX _B
Port 6 data register (PDR6)	R/W	000006 _H	XXXXXXXX _B
Port 7 data register (PDR7)	R/W	000007 _H	XXXXXXXX _B
Port 8 data register (PDR8)	R/W	000008 _H	XXXXXXXX _B
Port 0 data direction register (DDR0)	R/W	000010 _H	00000000 _B
Port 1 data direction register (DDR1)	R/W	000011 _H	00000000 _B
Port 2 data direction register (DDR2)	R/W	000012 _H	00000000 _B
Port 3 data direction register (DDR3)	R/W	000013 _H	00000000 _B
Port 4 data direction register (DDR4)	R/W	000014 _H	00000000 _B
Port 5 data direction register (DDR5)	R/W	000015 _H	XXXXXXXX00 _B
Port 6 data direction register (DDR6)	R/W	000016 _H	00000000 _B
Port 7 data direction register (DDR7)	R/W	000017 _H	00000000 _B
Port 8 data direction register (DDR8)	R/W	000018 _H	00000000 _B
A/D input enable register (ADER0)	R/W	0000C5 _H	11111111 _B
A/D input enable register (ADER1)	R/W	0000D0 _H	11111111 _B
Port 0 pull-up resistor setting register (RDR0)	R/W	00008C _H	00000000 _B
Port 1 pull-up resistor setting register (RDR1)	R/W	00008D _H	00000000 _B
Port 2 pull-up resistor setting register (RDR2)	R/W	00008E _H	00000000 _B
Port 3 pull-up resistor setting register (RDR3)	R/W	00008F _H	00000000 _B

R/W: Read/write enabled

X : Undefined

(3) Block diagram

- Block diagram of Port 0 (P00 to P06), Port 1 (P17) and Port 2 (excluding P21) pins

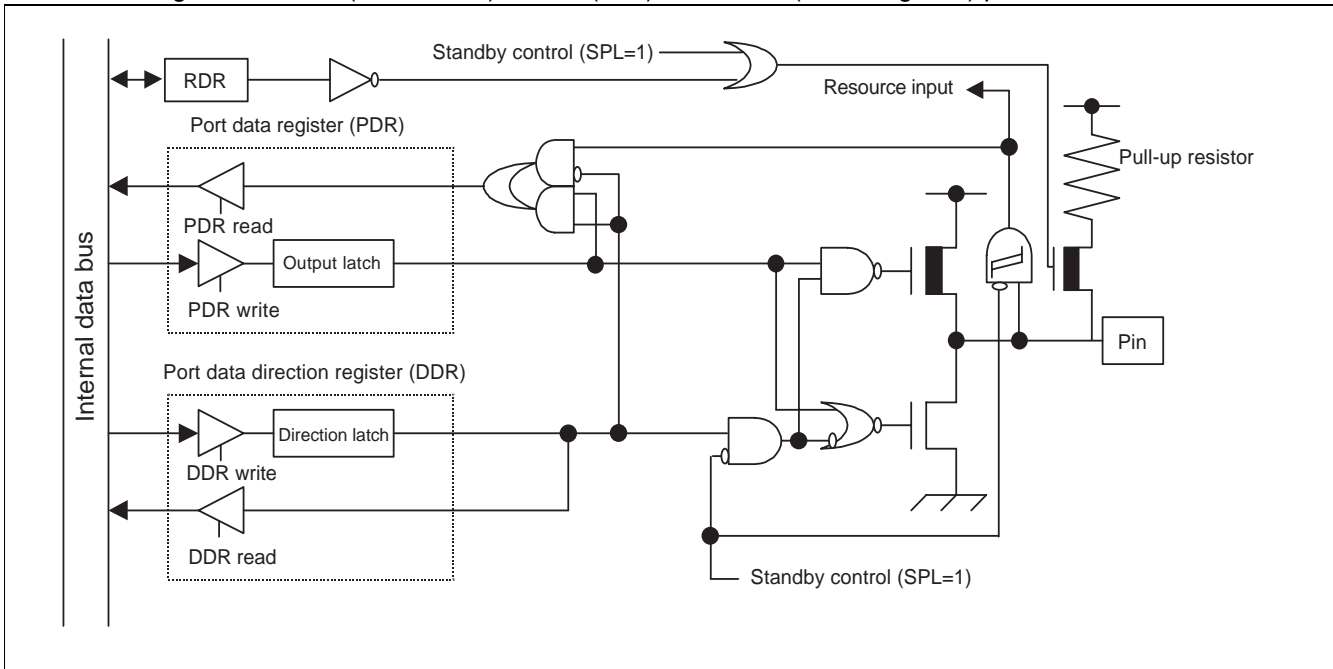

- Block diagram of Port 0 (P07) and Port 2 (P21) pins

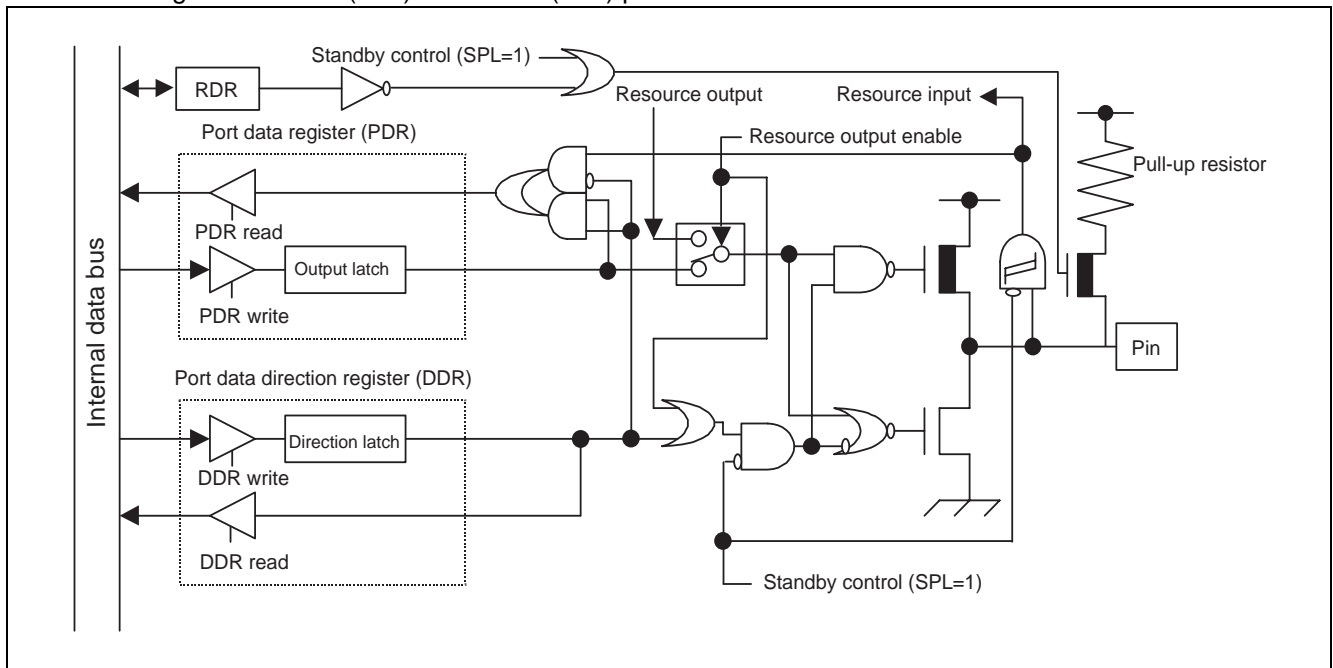

MB90820 Series

- Block diagram of Port 1 (P10 to P16) pins

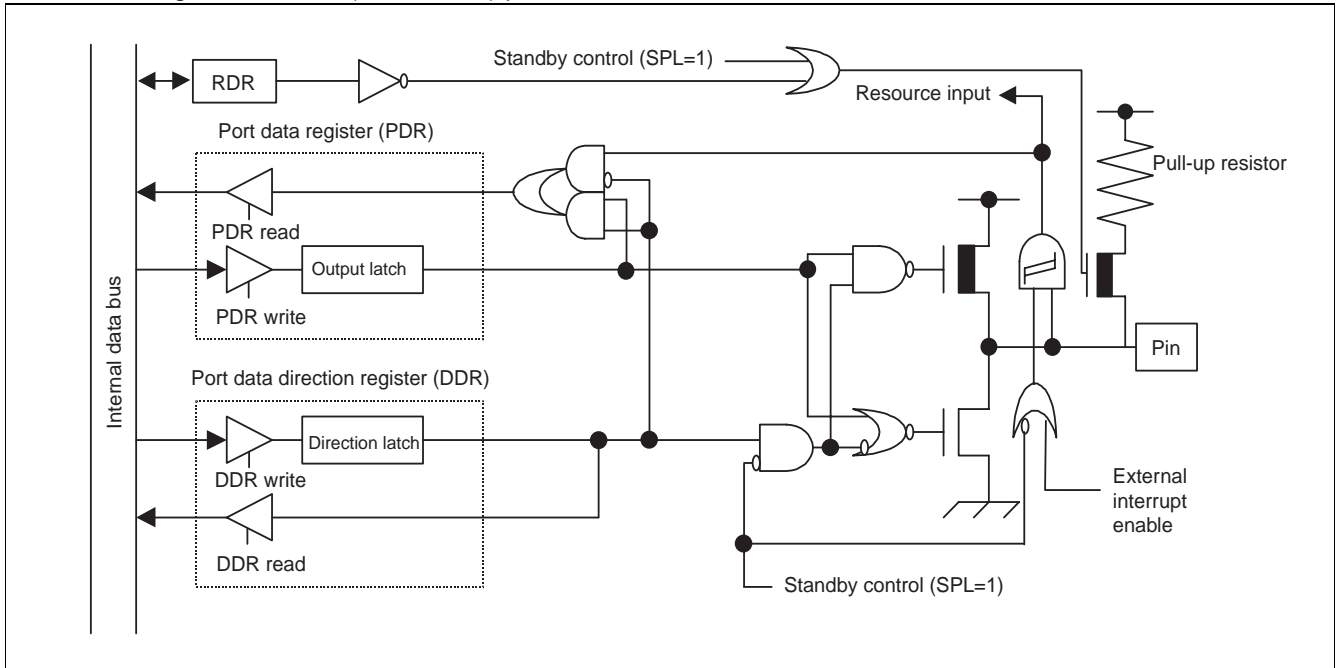

- Block diagram of Port 3 (excluding P37) pins

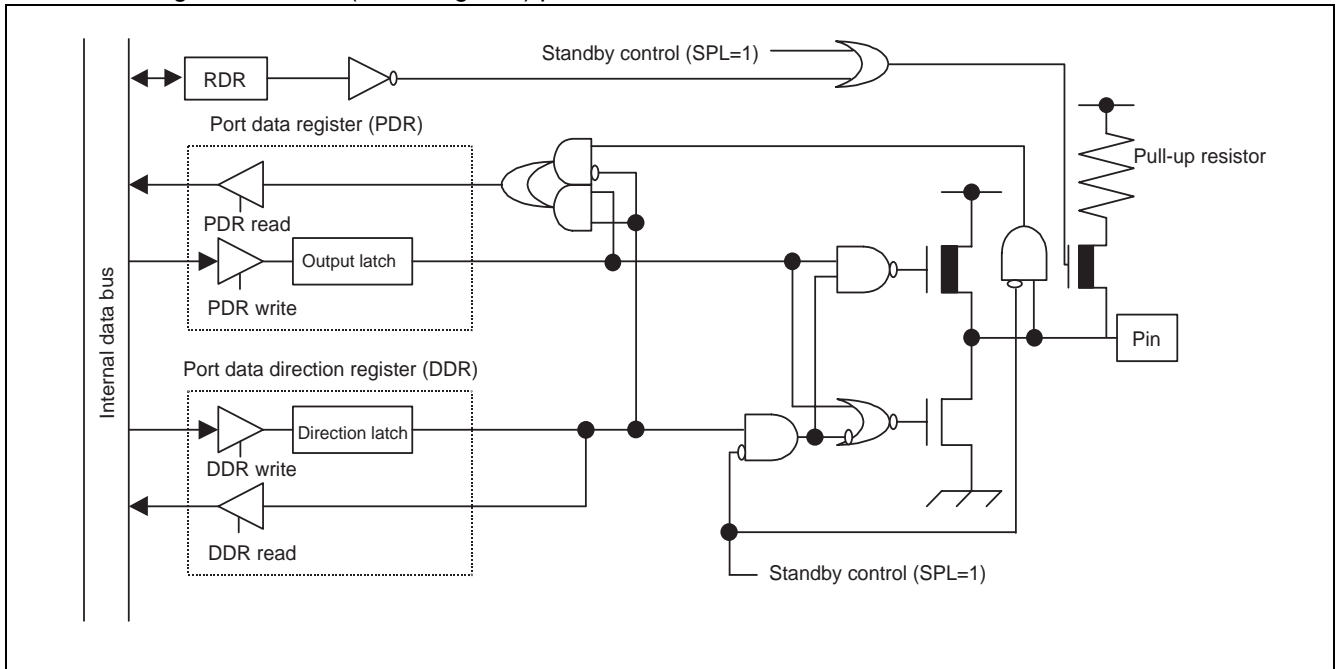

- Block diagram of Port 3 (P37) pin

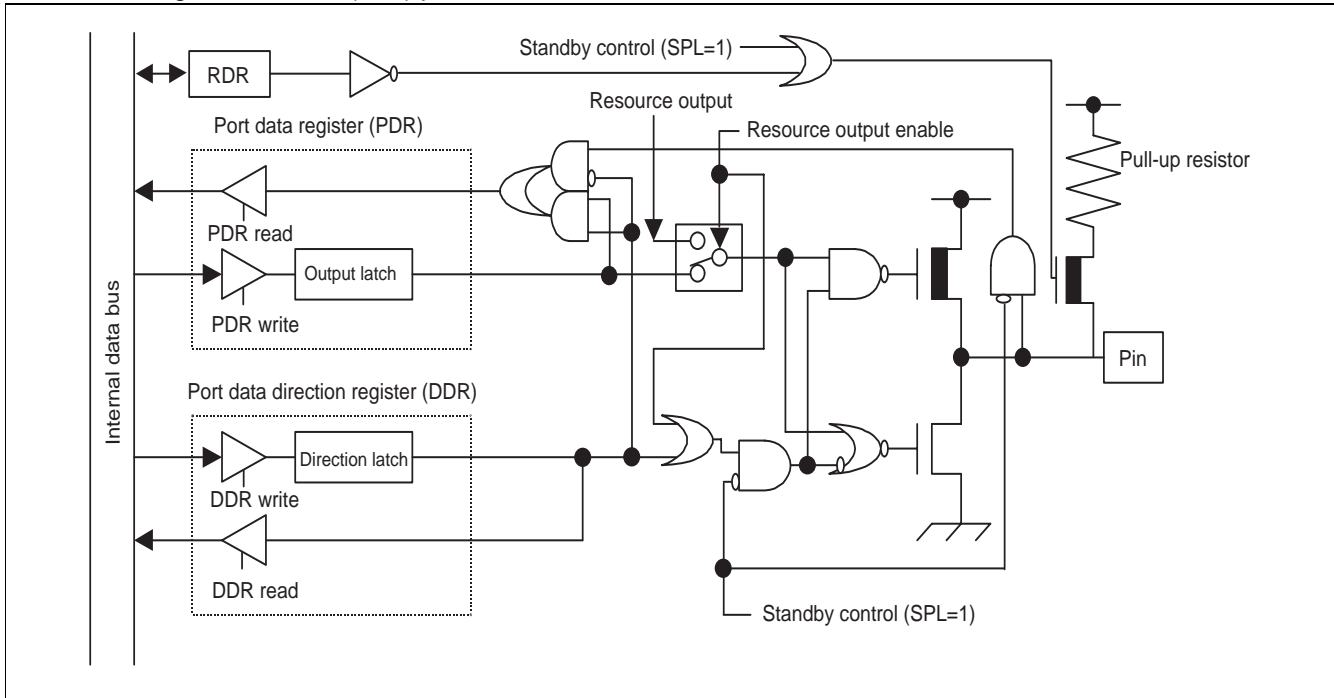

- Block diagram of Port 4 pins (excluding P41, P45 and P46) pins

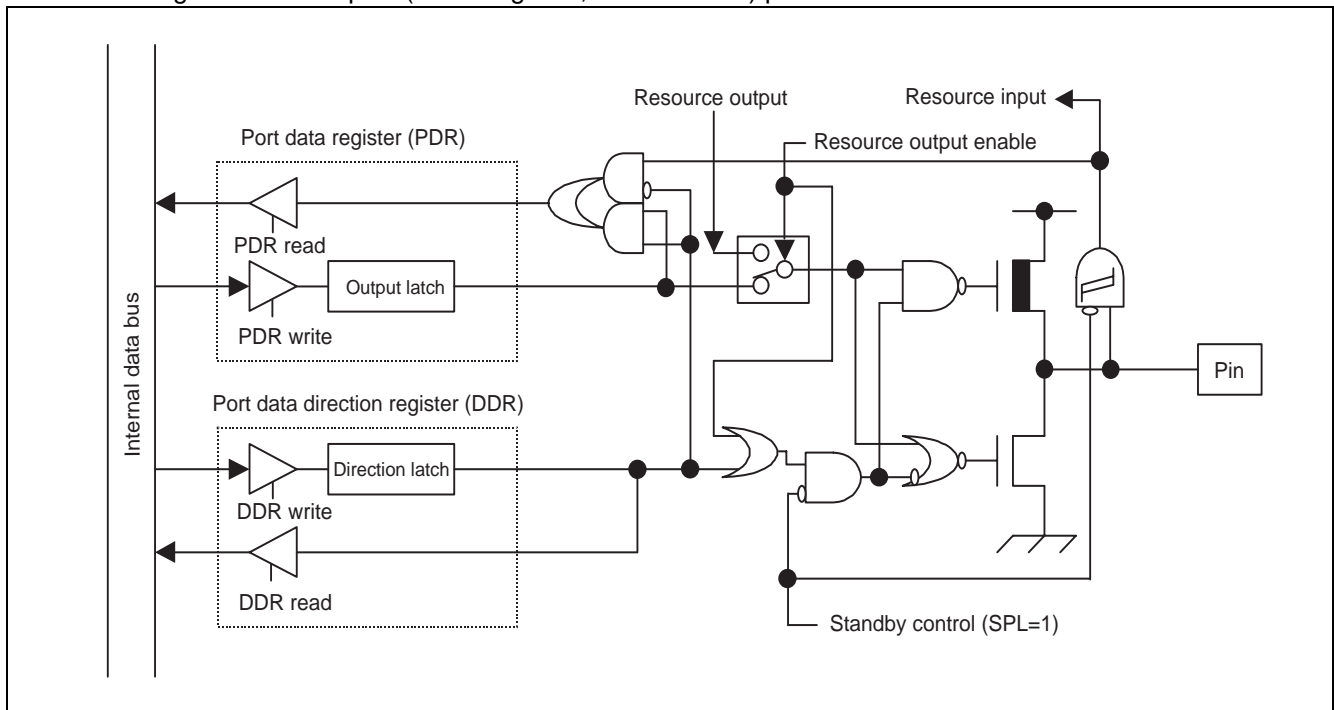

MB90820 Series

- Block diagram of Port 4 (P41 and P46) pins

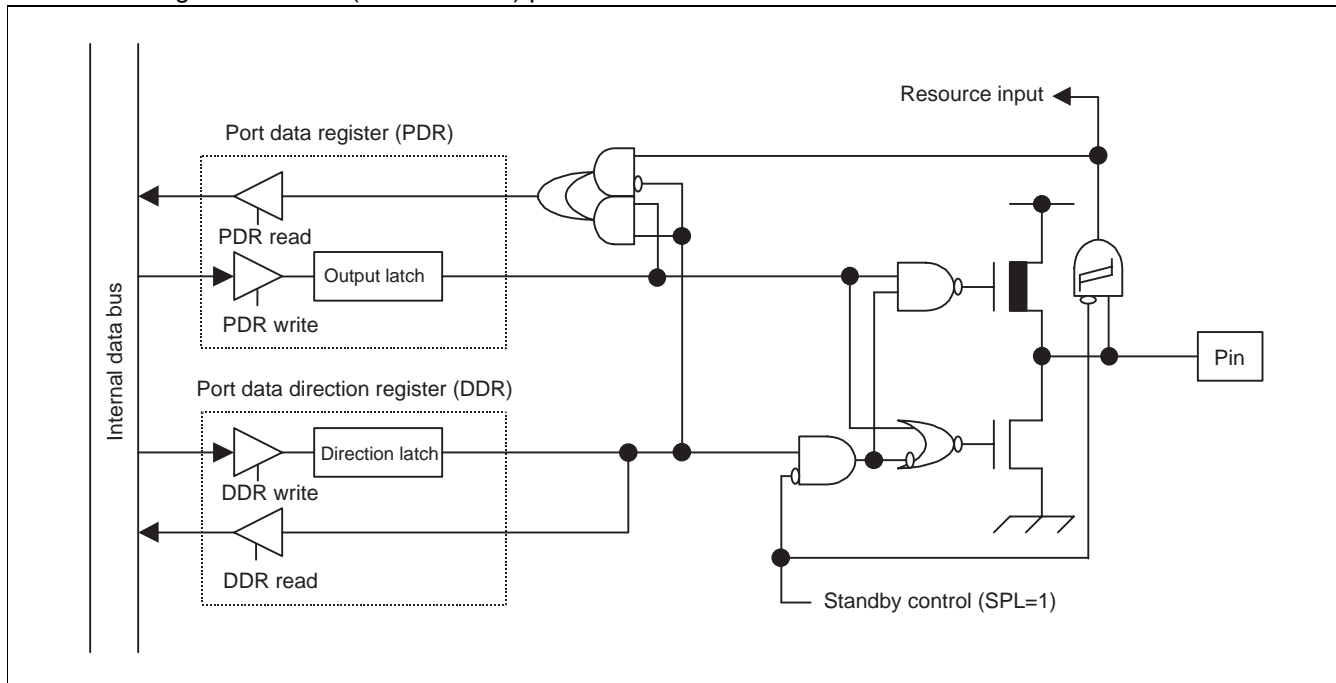

- Block diagram of P45 pin

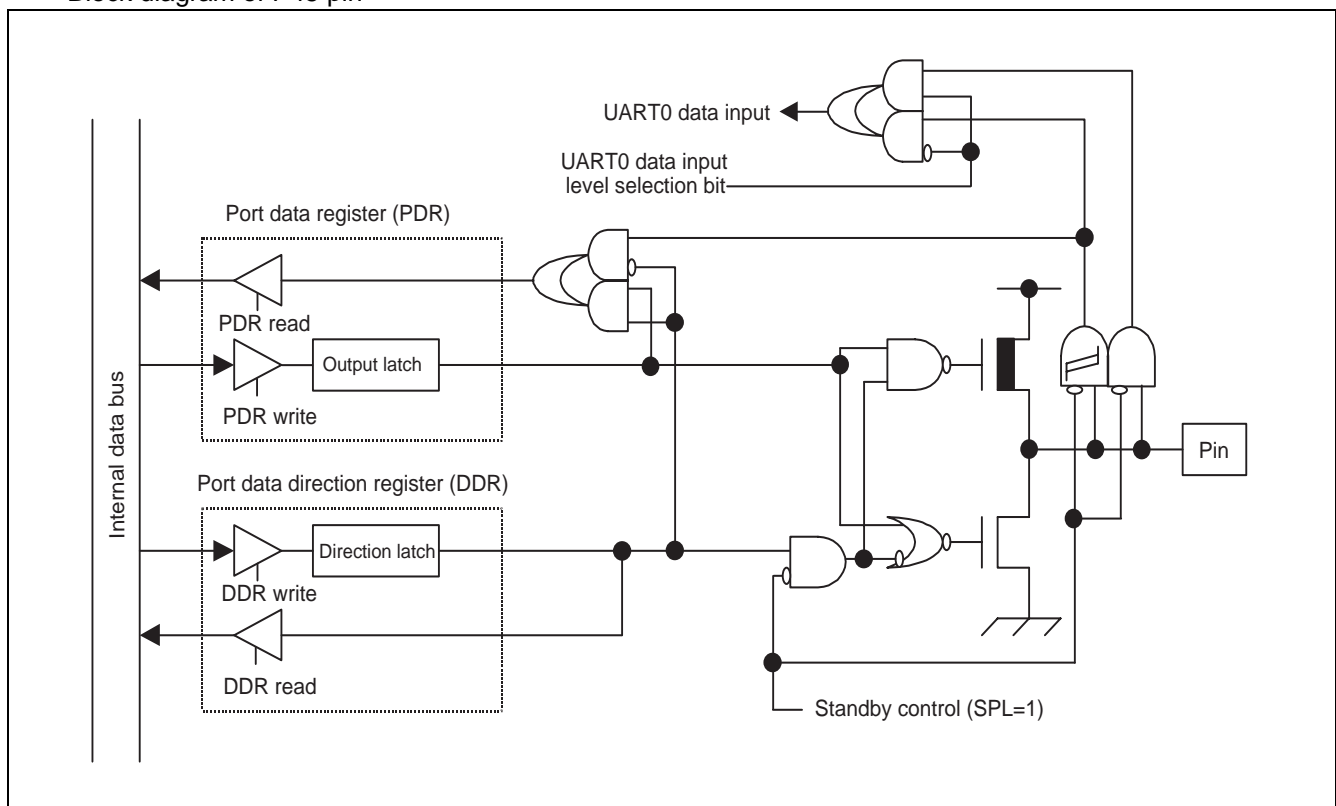

- Block diagram of Port 5 (P50) pin

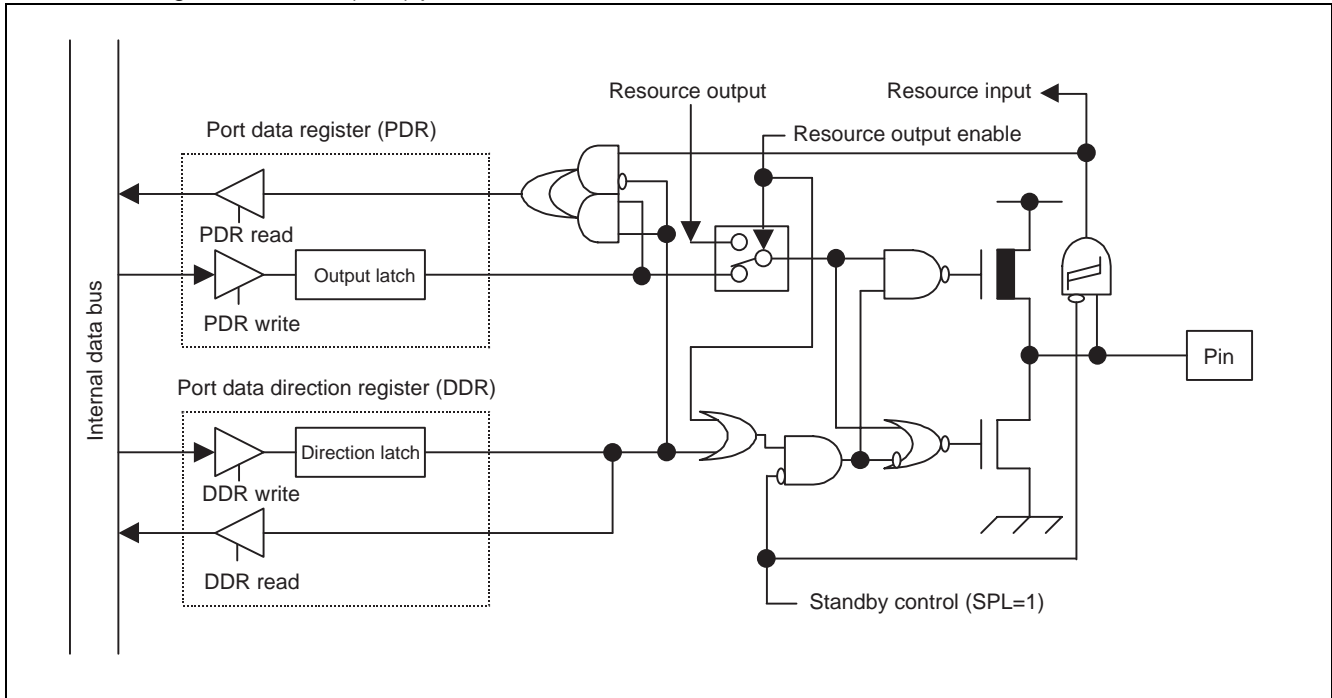

- Block diagram of Port 5 (P51) pin

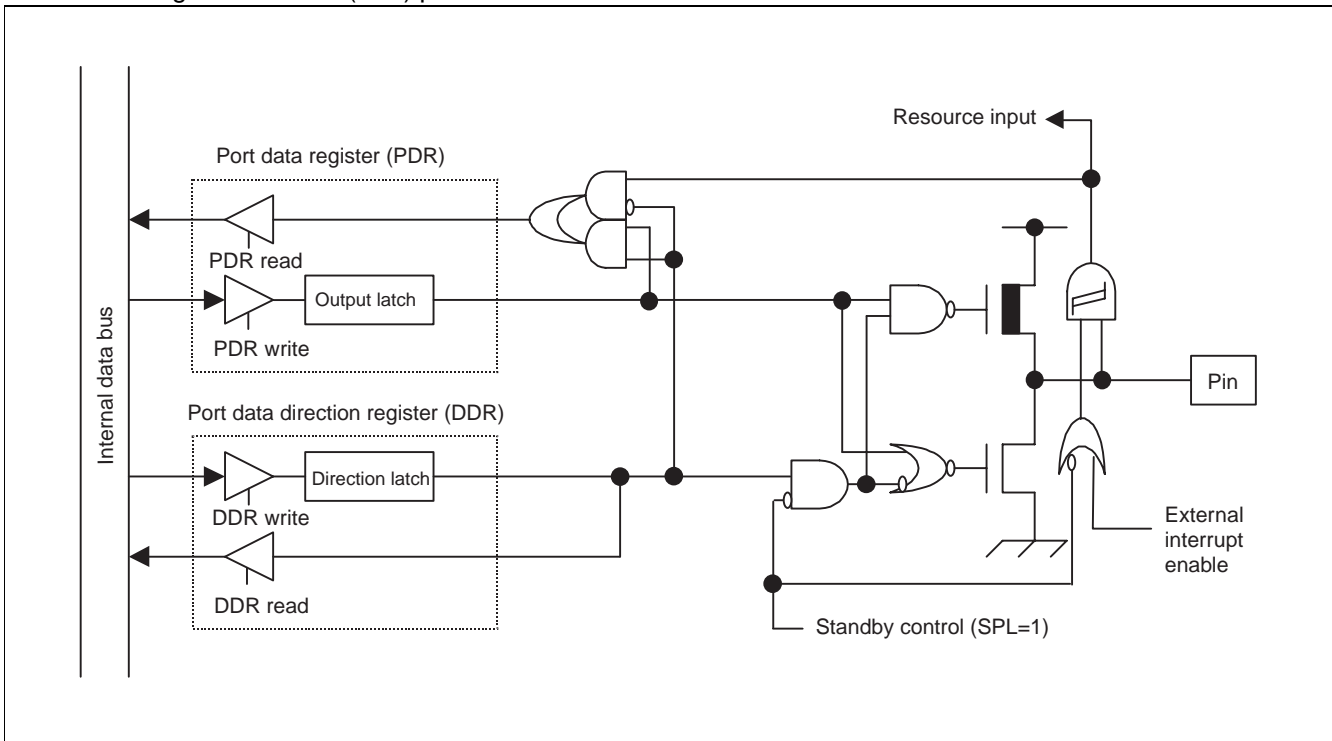

MB90820 Series

- Block diagram of Port 6 pins

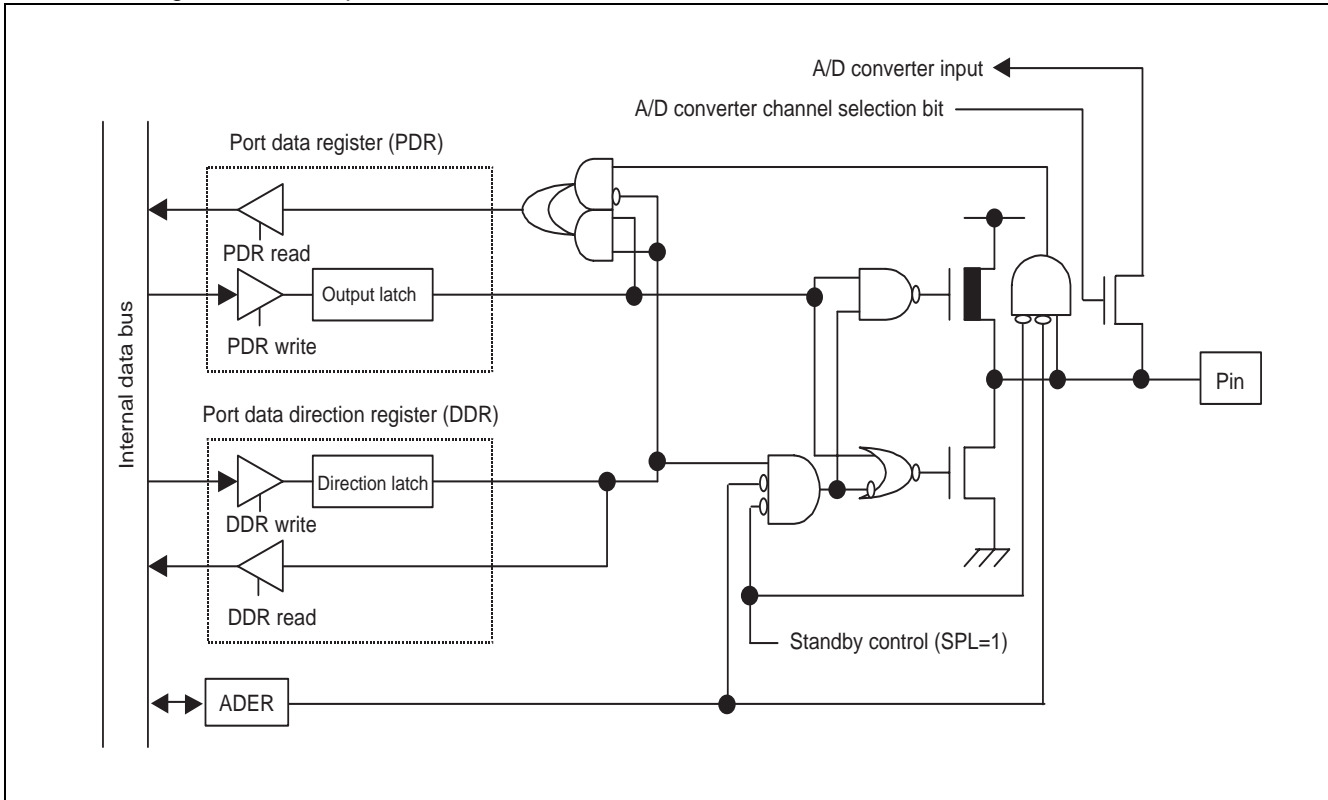

- Block diagram of Port 7 (P70, P71) pins

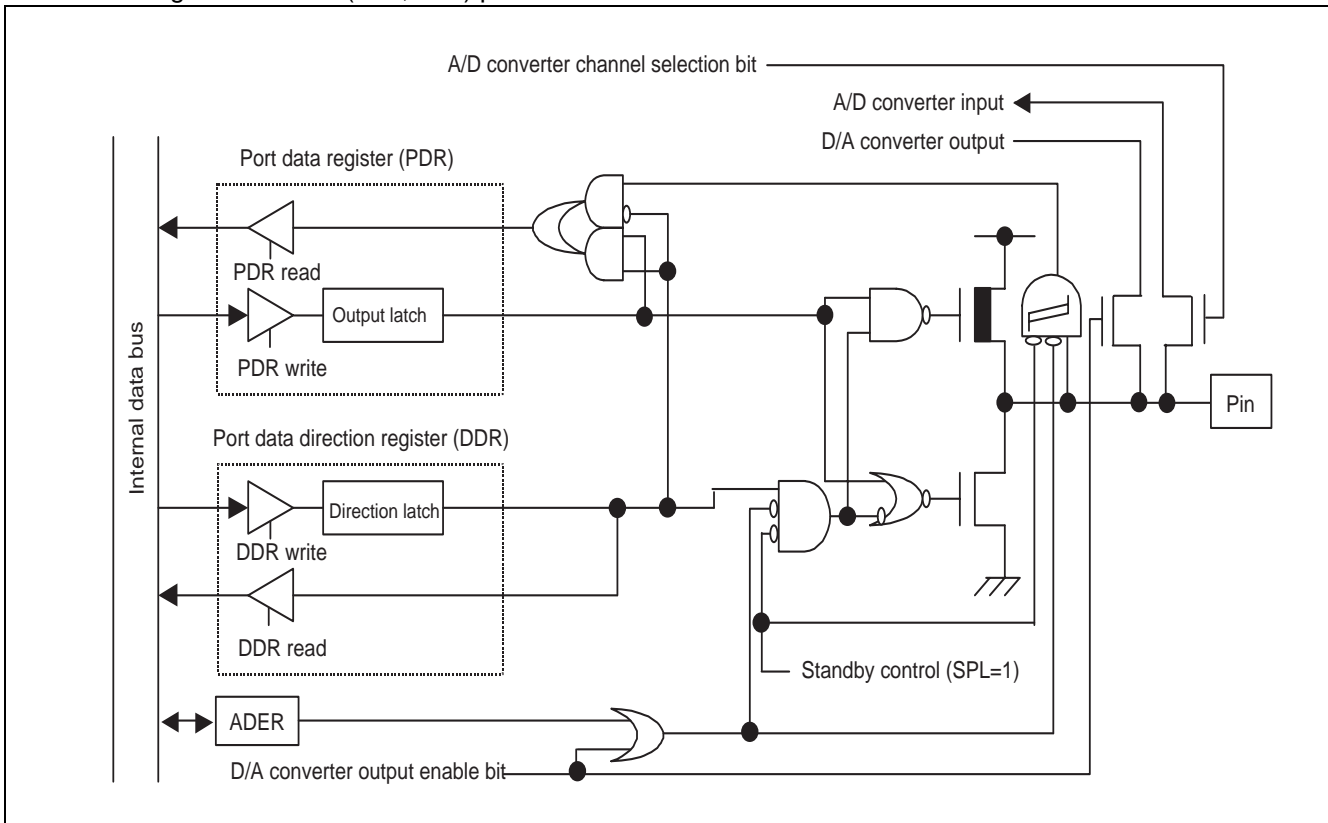

• Block diagram of P72 pin

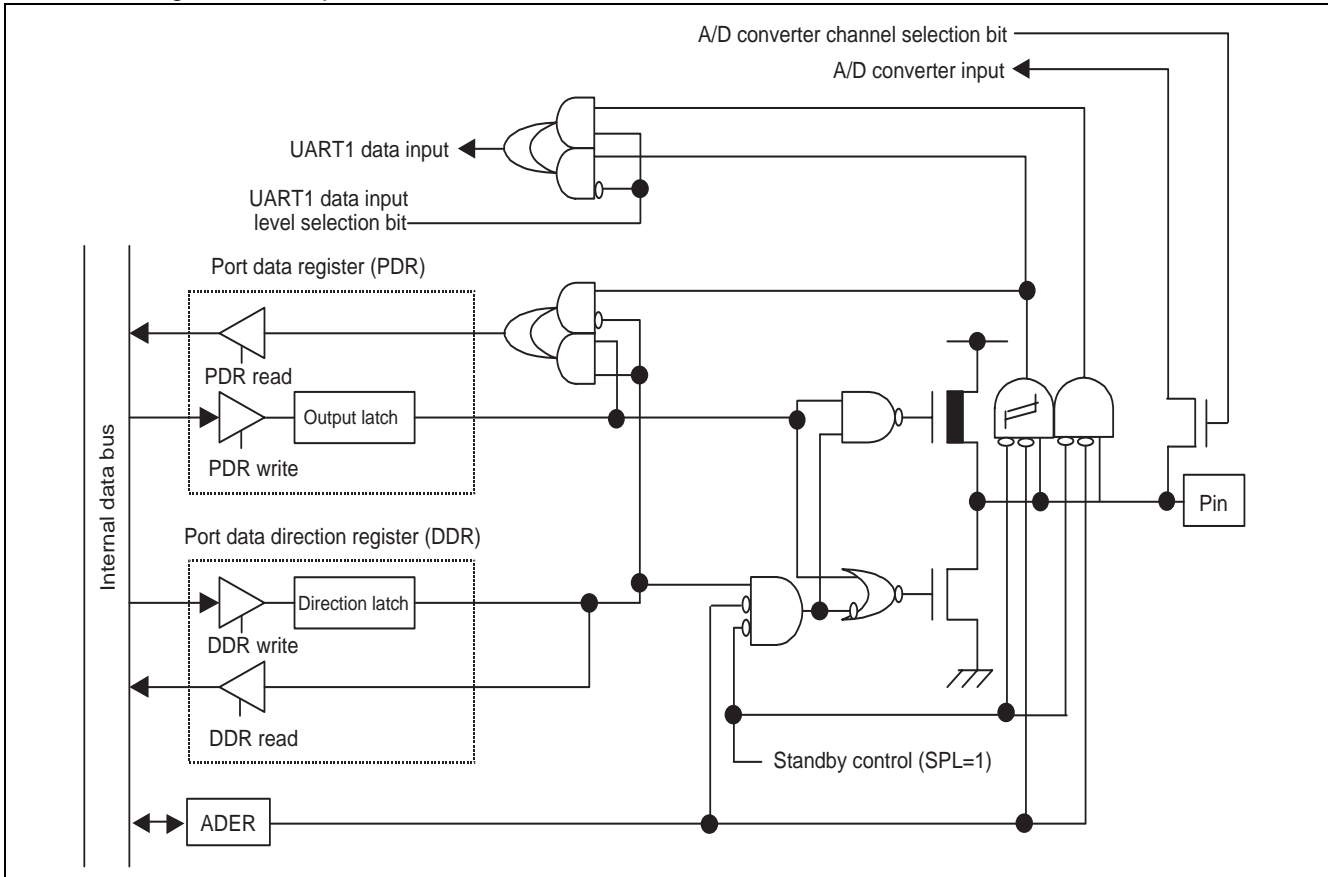

• Block diagram of Port 7(P73, P74) pins

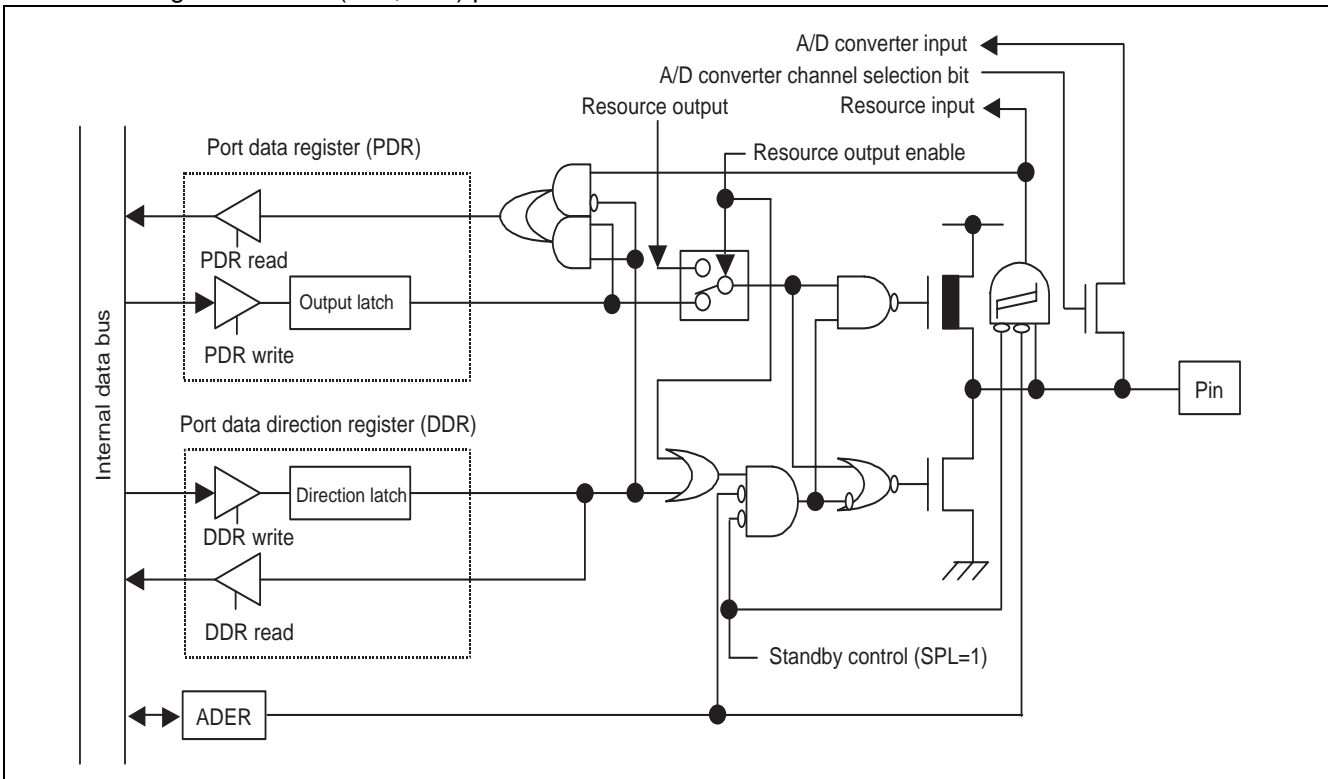

MB90820 Series

- Block diagram of Port 7 (P75 to P77) pins

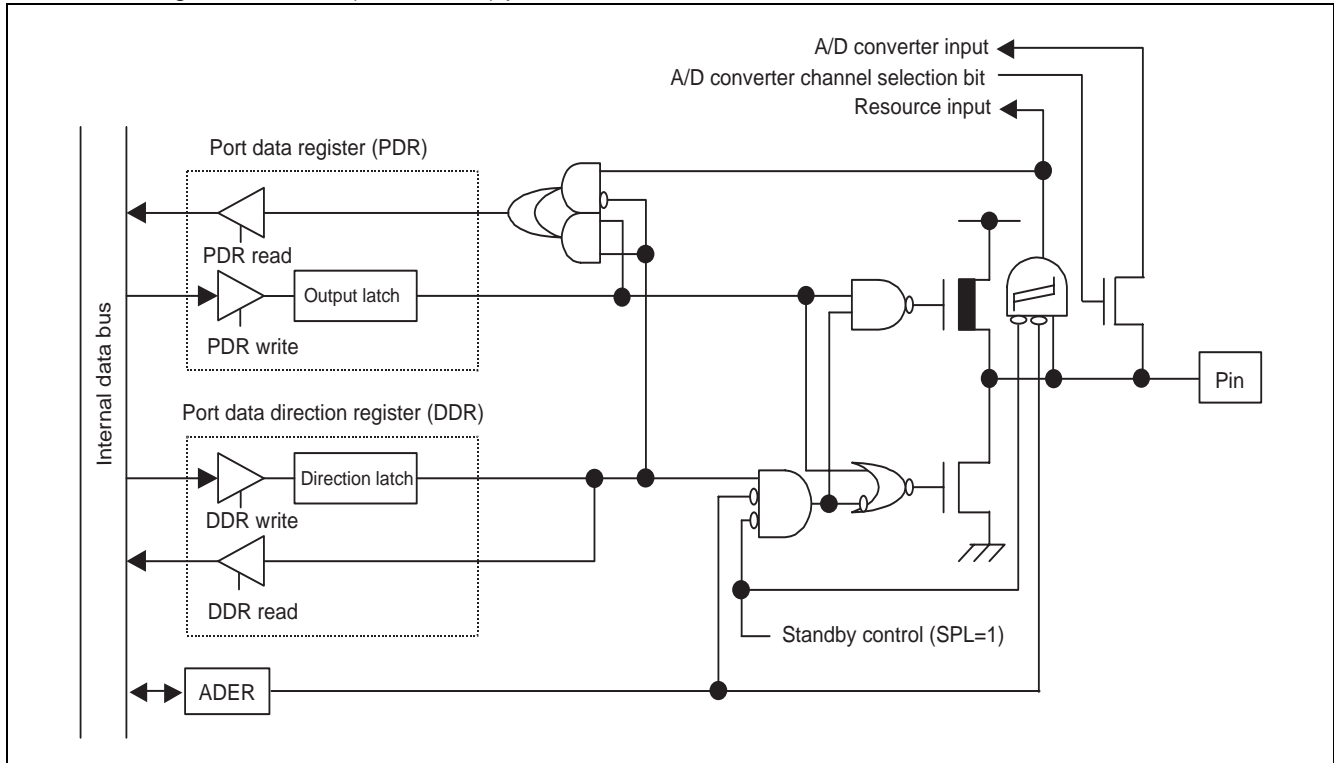

- Block diagram of Port 8 (P80, P81) pins

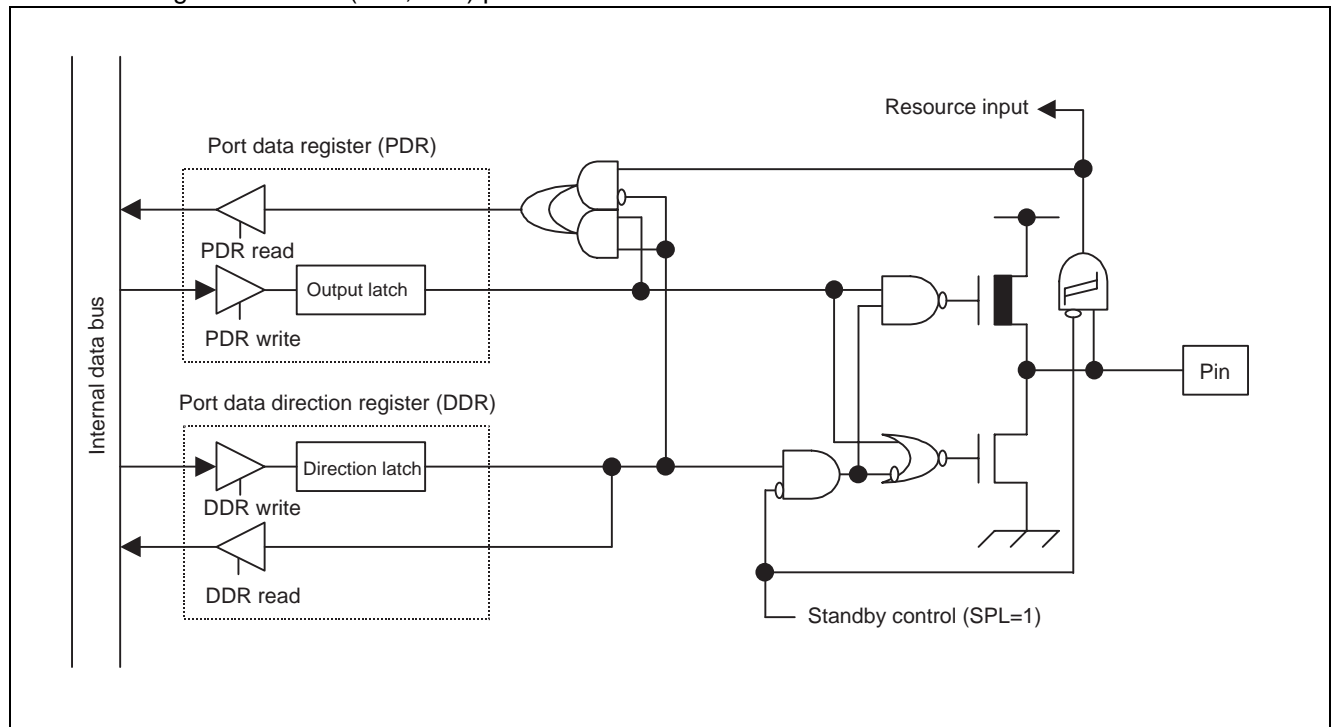

- Block diagram of Port 8 (P82 to P87) pins

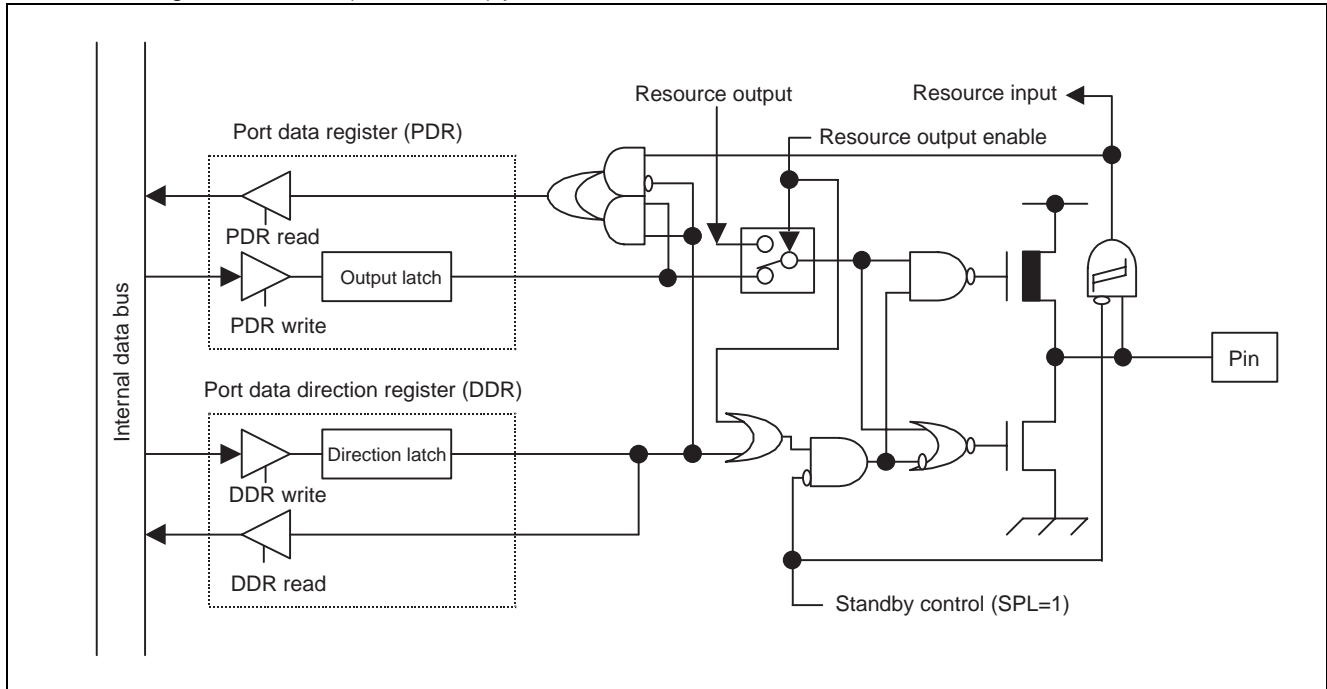

MB90820 Series

3. Timebase Timer

The timebase timer is an 18-bit free-running counter (timebase counter) that counts up in synchronization with the internal count clock (divided by 1/2 of oscillation clock).

Features of timebase timer :

- Generates the interruption at counter-overflow
- Supports for EI²OS
- Interval timer function:
Generates an interrupt at four different time intervals
- Clock supply function:
Four different clock can be selected as watchdog timer's count clock
Supply clock for oscillation stabilization

(1) Register configuration

Timebase Timer Control Register									
	15	14	13	12	11	10	9	8	Bit number
Address: 0000A9H	Reserved	—	—	TBIE	TBOF	TBR	TBC1	TBC0	TBTC
Read/write	R/W	—	—	R/W	R/W	W	R/W	R/W	
Initial value	1	X	X	0	0	1	0	0	

(2) Block diagram

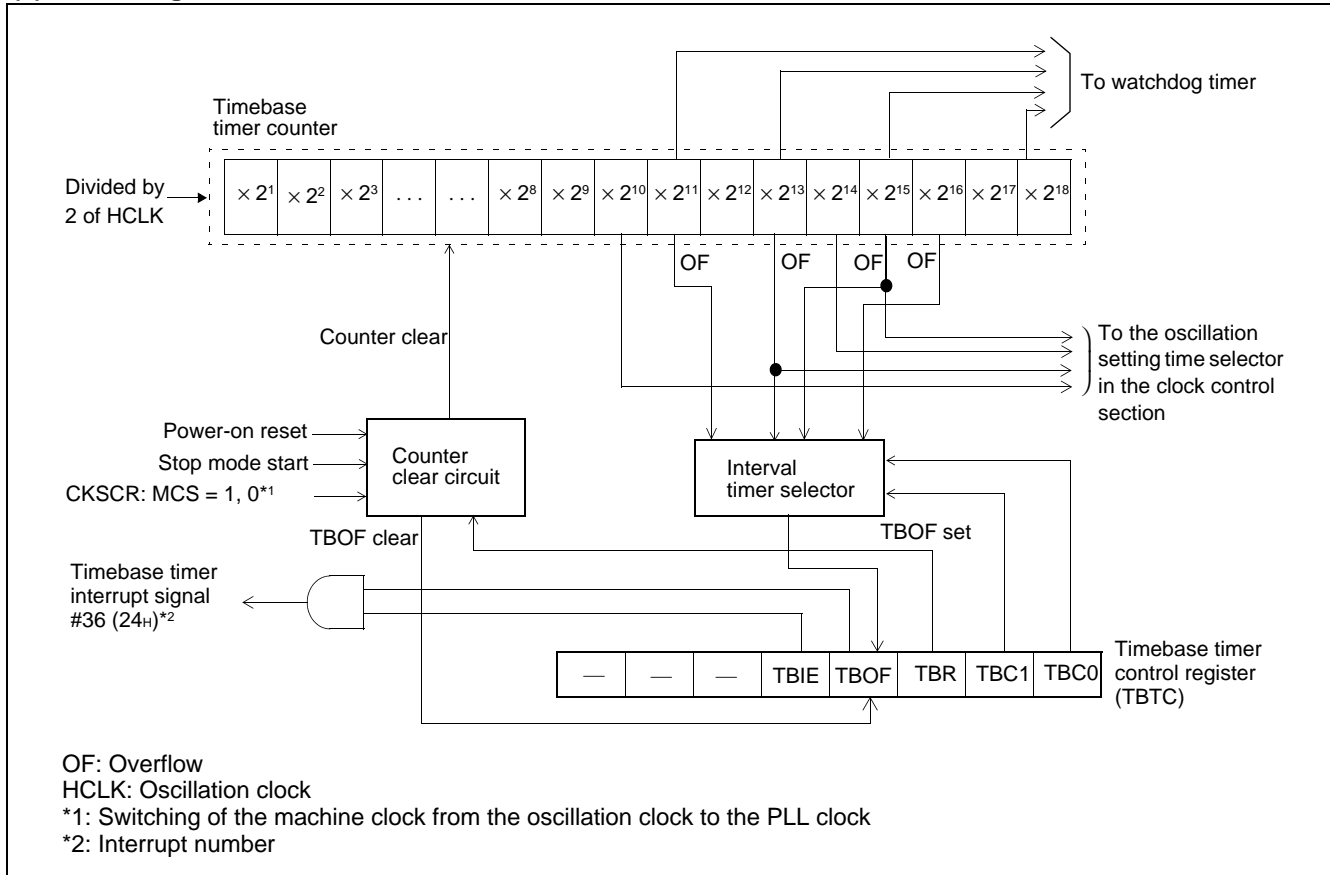

4. Watchdog Timer

The watchdog timer is a 2-bit counter that uses the timebase timer's supply clock as the count clock. After activation, if the watchdog timer is not cleared within a given period, the CPU will be reset.

- Features of watchdog timer :

Reset CPU at four different time intervals

Indicate the reset causes by status bits

(1) Register configuration

Watchdog Timer Control Register								Bit	
	7	6	5	4	3	2	1	0	
Address: 0000A8H	PONR	—	WRST	ERST	SRST	WTE	WT1	WT0	WDTC
Read/write	R	—	R	R	R	W	W	W	
Initial value	X	X	X	X	X	1	1	1	

(2) Block diagram

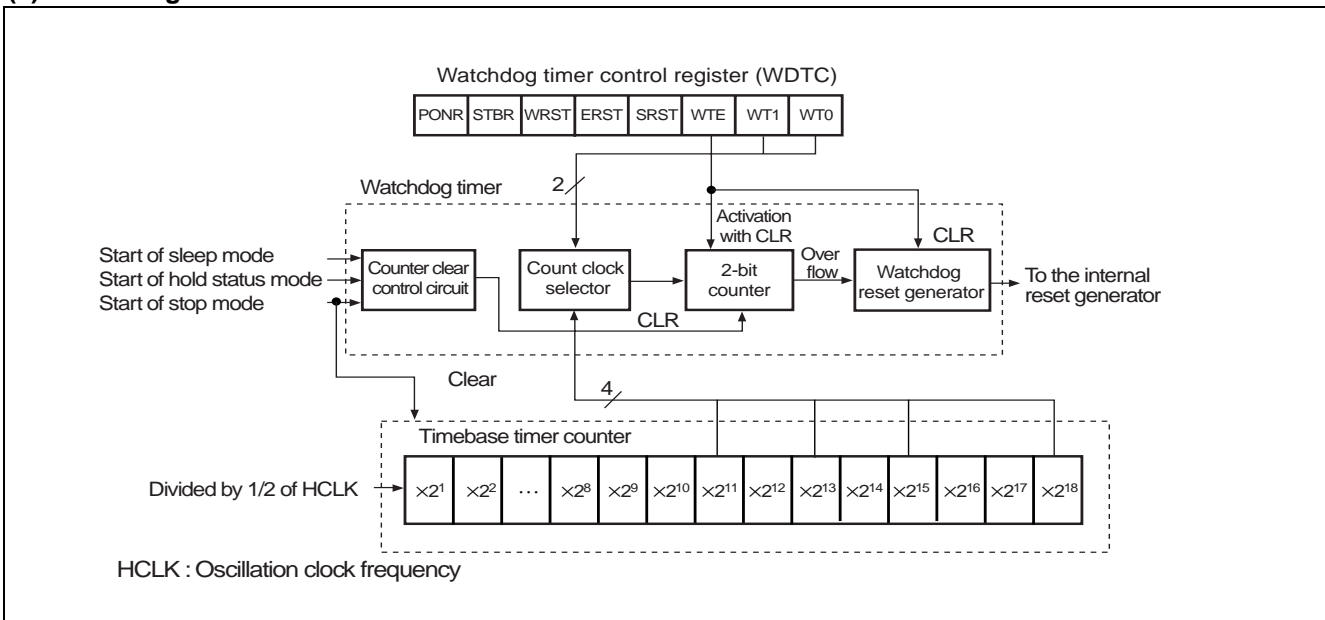

MB90820 Series

5. 16-bit reload timer (x 2)

The 16-bit reload timer provides two operating mode, internal clock mode and event count mode. In each operating mode, the 16-bit down counter can be reloaded (reload mode) or stopped by underflow (one-shot mode).

Output pins TO1 and TO0 are able to output different waveform according to the counter operating mode. TO1 and TO0 toggles when counter underflows if counter is operated as reload mode. TO1 and TO0 output specified level (H or L) during counting if the counter is in one-shot mode.

Features of the 16-bit reload timer :

- Interrupt when timer underflows
- Supports for EI²OS
- Internal clock operating mode :
Three internal count clocks can be selected.
Counter can be activated by software or external trigger (signal at TIN1 and TIN0 pins).
Counter can be reloaded or stopped when underflow after activated.
- Event count operating mode :
Counter counts down one by one with specified edge at TIN1 and TIN0 pins.
Counter can be reloaded or stopped when underflow.

(1) Register configuration

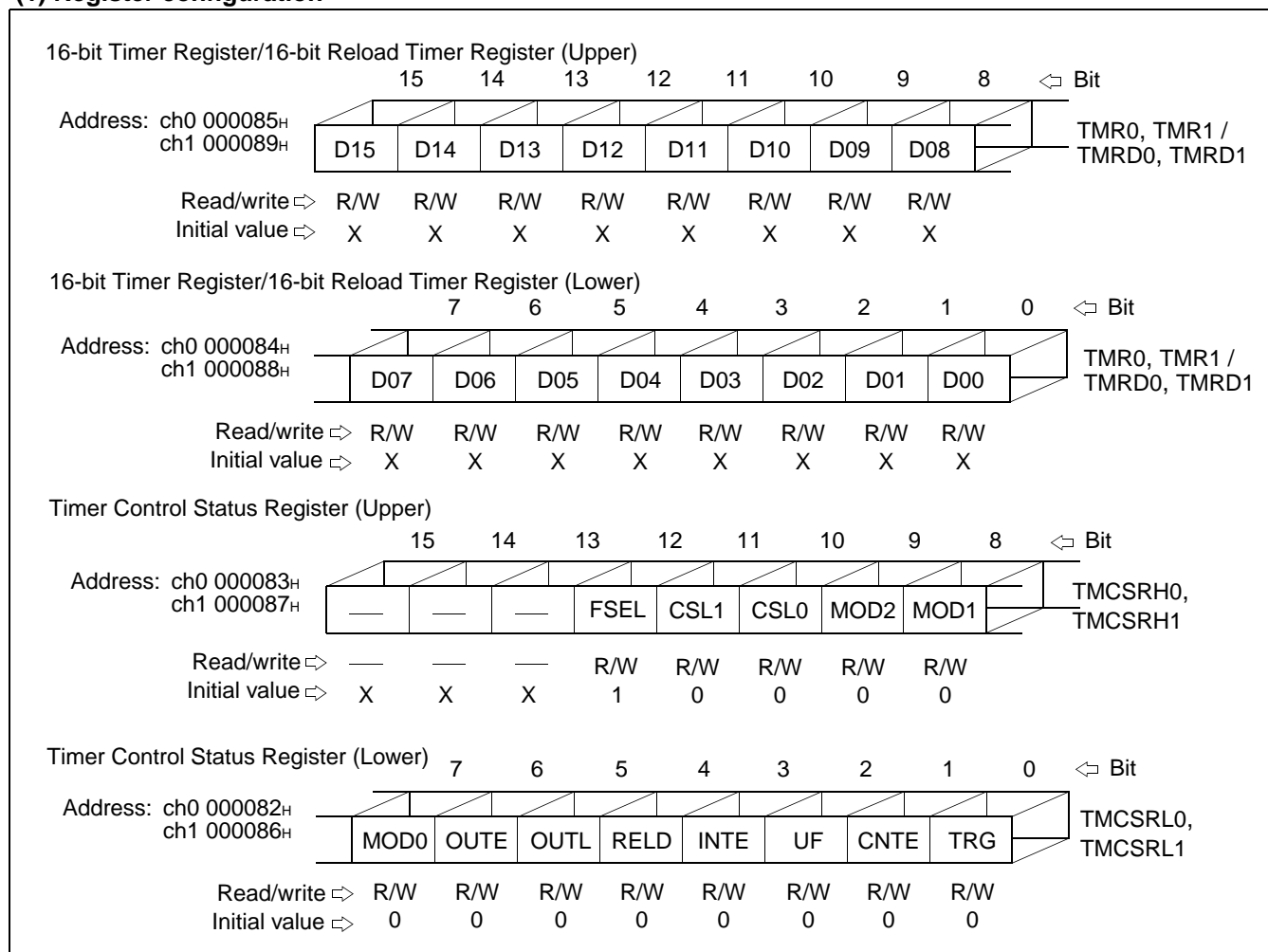

Note : Registers TMR0, TMR1/TMRD0, TMRD1 are word access only.

(2) Block diagram

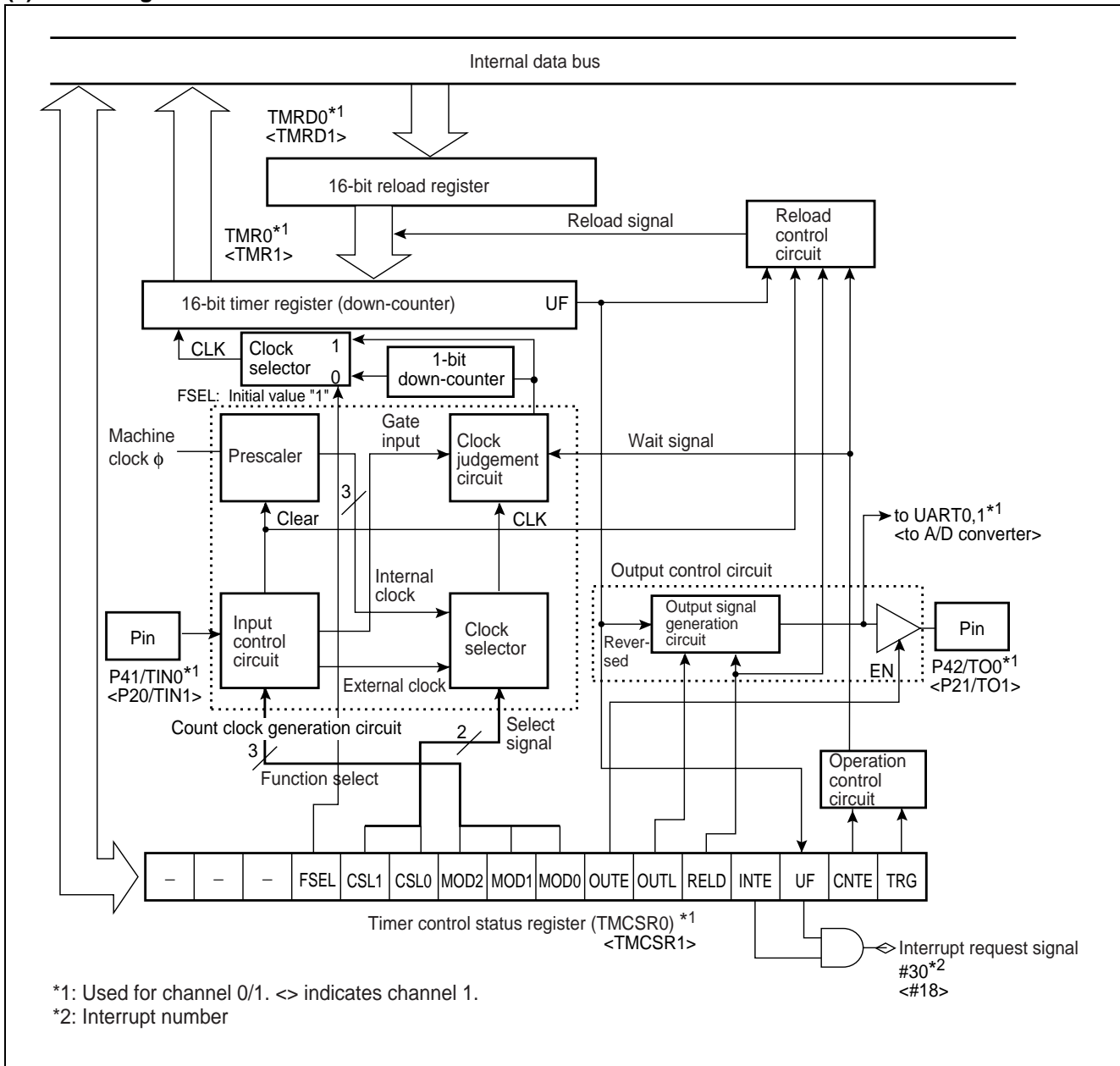

MB90820 Series

6. 16-bit PPG Timer (x 3)

The 16-bit PPG timer consists of a 16-bit down counter, prescaler, 16-bit period setting register, 16-bit duty setting register, 16-bit control register and a PPG output pin. This module can be used to output pulses synchronized by software trigger or GATE signal from Multi-functional timer, refer to "7. Multi-functional Timer".

Features of 16-bit PPG timer :

- Two operating mode : PWM and One-shot mode
- 8 types of counter operation clock (ϕ , $\phi/2$, $\phi/4$, $\phi/8$, $\phi/16$, $\phi/32$, $\phi/64$, $\phi/128$) can be selected
- Interrupt is generated when trigger signal arrived, or counter borrow, or change of PPG output
- Supports for EI²OS

(1) Register configuration

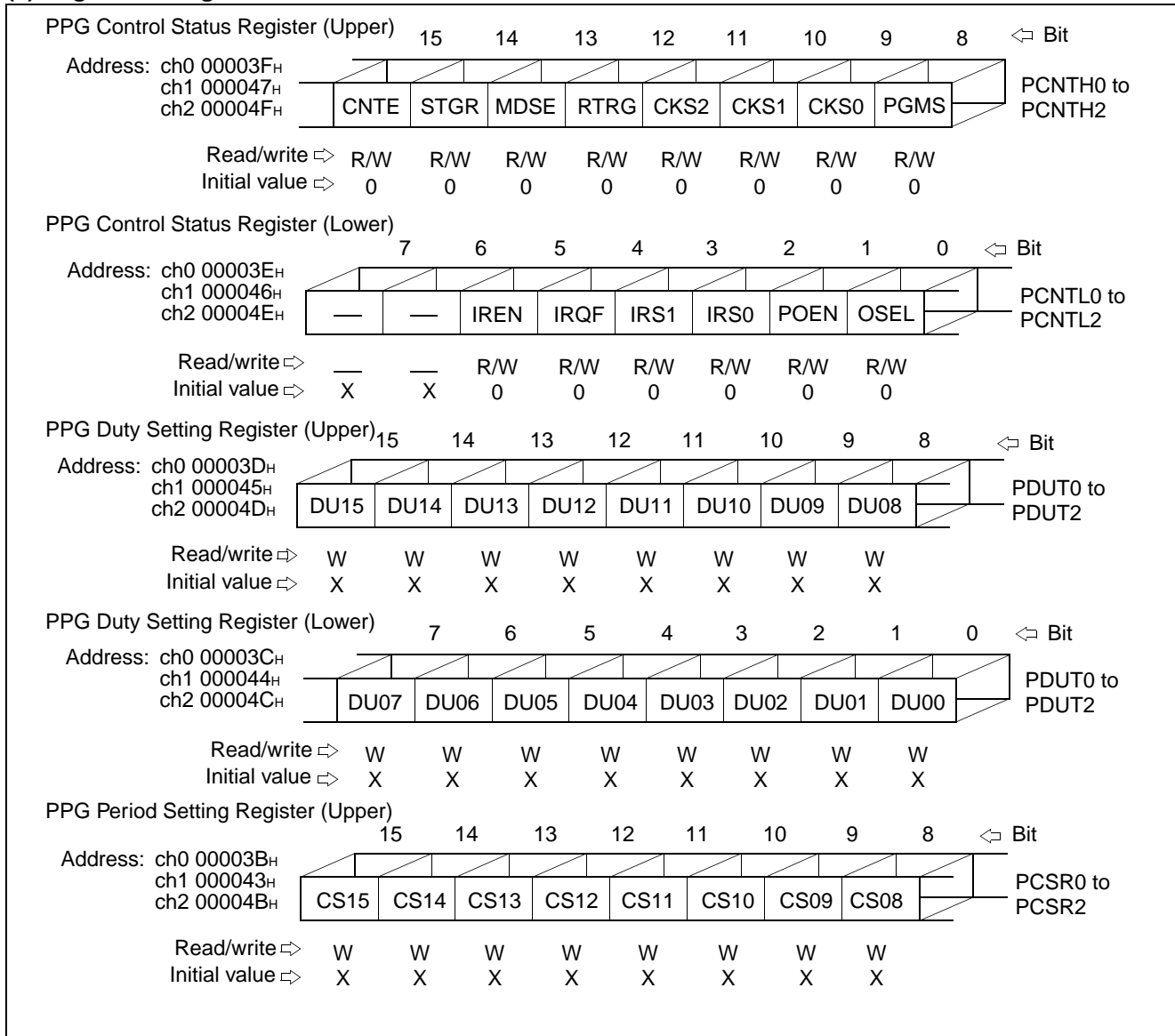

(Continued)

(Continued)

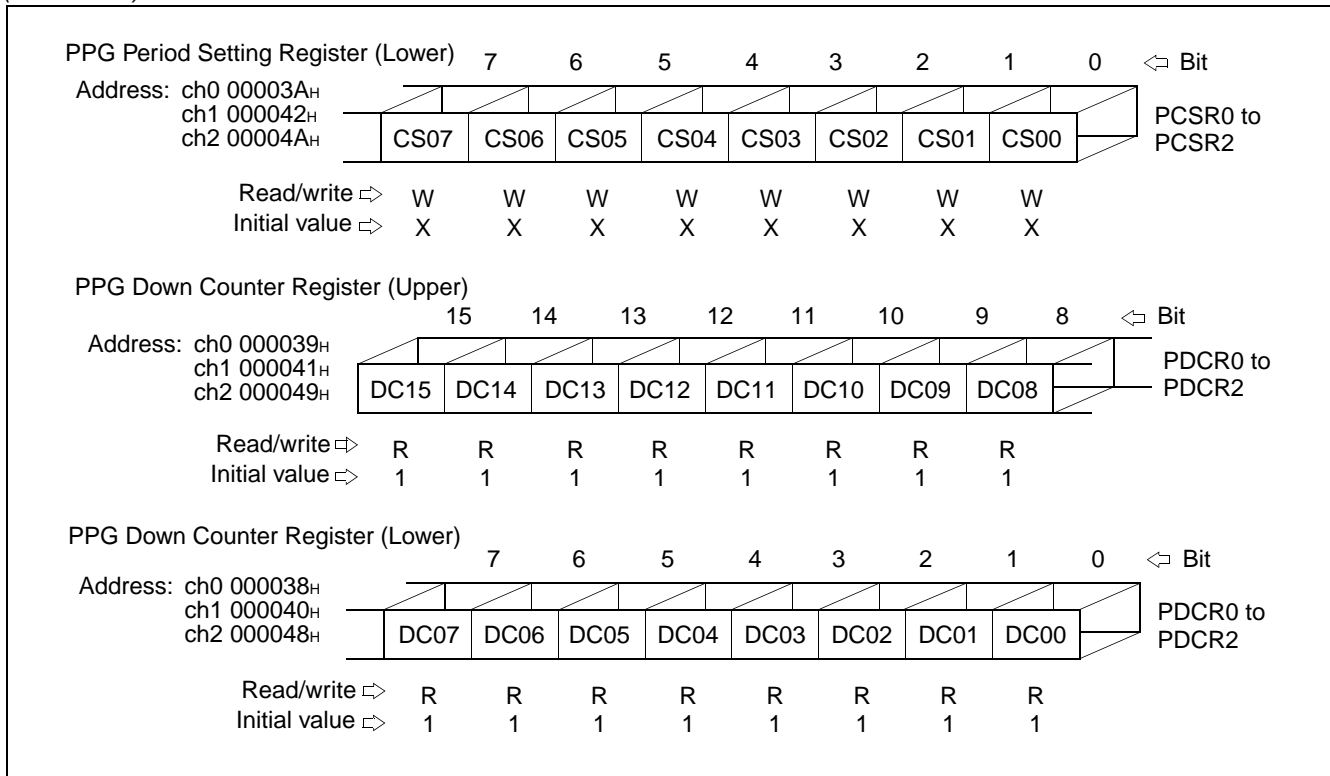

Note : Registers PDCR0 to PDCR2, PDSR0 to PDSR2 and PDUT0 to PDUT2 are word access only.

MB90820 Series

(2) Block diagram

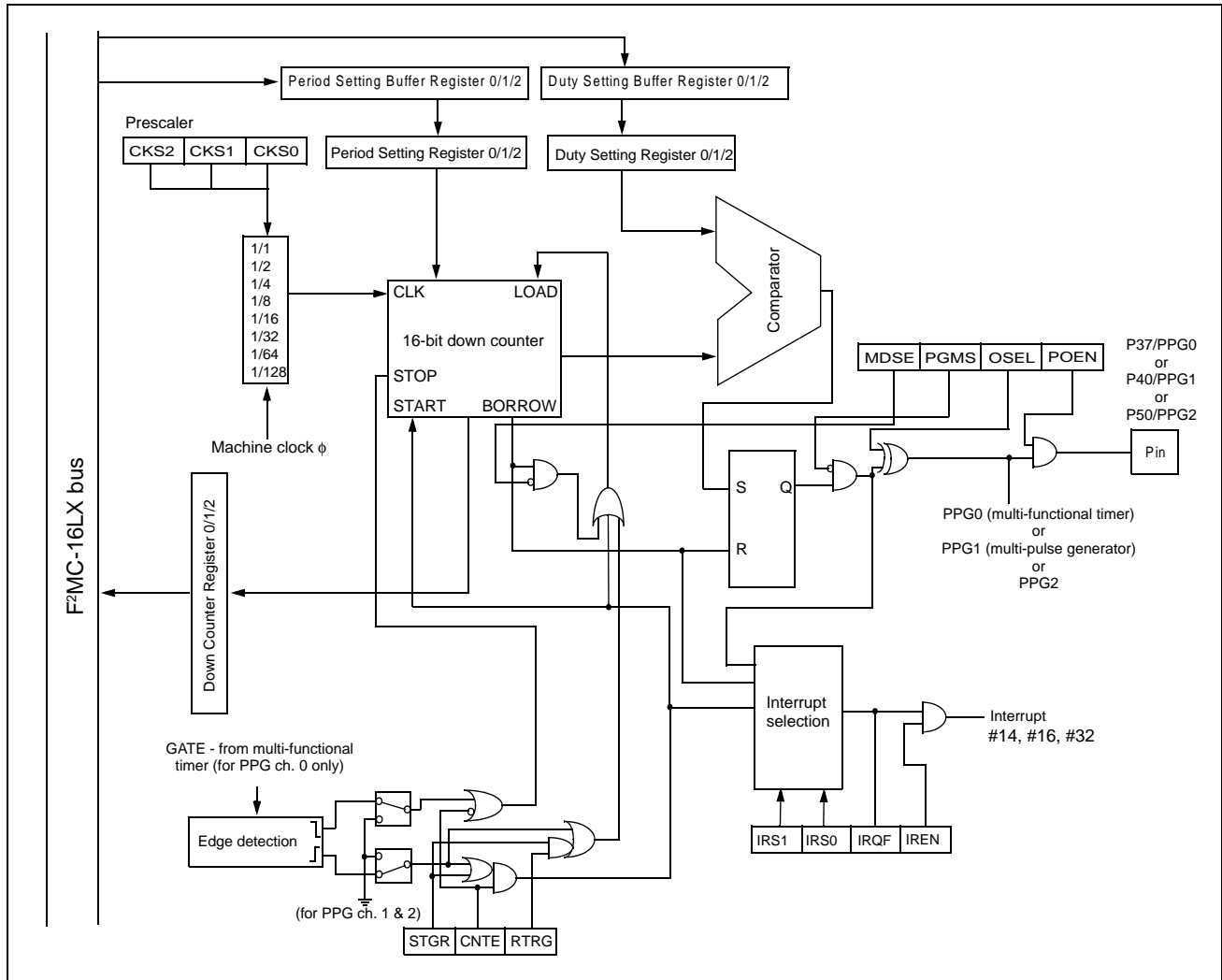

7. Multi-functional Timer

The 16-bit multi-functional timer module consists of one 16-bit free-running timer, four input capture circuits, six output comparators and one channel of 16-bit PPG timer. This module allows six independent waveforms generated by PPG timer or waveform generator to be outputted. With the 16-bit free-running timer and the input capture circuit, input pulse width and external clock period measurement can be done.

(1) 16-bit free-running timer (1 channel)

- The 16-bit free-running timer consists of a 16-bit up/up-down counter, timer control status register, 16-bit compare clear register (with buffer register) and a prescaler.
- 8 types of counter operation clock (ϕ , $\phi/2$, $\phi/4$, $\phi/8$, $\phi/16$, $\phi/32$, $\phi/64$, $\phi/128$) can be selected. (ϕ is the machine clock.)
- Two types of interrupt causes :
 - Compare clear interrupt is generated when there is a comparing match with compare clear register and 16-bit free-running timer.
 - Zero detection interrupt is generated while 16-bit free-running timer is detected as zero in count value.
- EI²OS supported.
- Compare-clear register buffer provided :
The selectable buffer enables the 16-bit free-running timer update its compare-clear register automatically without stop the timer operation. User can read the next compare-clear value to the compare-clear register when the timer is running. The compare-clear register will be updated when the timer value is "0000H".
- Reset, software clear, compare match with compare clear register in up-count mode will reset the counter value to "0000H".
- Supply clock to output compare module :
The prescaler output is acted as the count clock of the output compare.

(2) Output compare module (6 channels)

- The output compare module consists of six 16-bit output compare registers (with selectable buffer register), compare output latch and compare control registers. An interrupt is generated and output level is inverted when the value of 16-bit free-running timer and output compare register are matched.
- 6 output compare registers can be operated independently.
- Output pins and interrupt flag are corresponding to each output compare register.
- 2 output compare registers can be paired to control the output pins.
- Inverts output pins by using 2 output compare registers together.
- Setting the initial value for each output pin is possible.
- Interrupt is generated when there is a comparing match with output compare register and 16-bit free-running timer.
- EI²OS supported.

(3) Input capture module (4 channels)

Input capture consists of 4 independent external input pins, the corresponding input capture data register and input capture control status register. By detecting any edge of the input signal from the external pin, the value of the 16-bit free-running timer can be stored in the capture register and an interrupt is generated simultaneously.

- Operations synchronized with the 16-bit free-running timer's count clock.
- 3 types of trigger edge (rising edge, falling edge and both edge) of the external input signal can be selected and there is indication bit to show the trigger edge is rising or falling.
- 4 input captures can be operated independently.
- Two independent interrupts are generated when detecting a valid edge from external input.
- EI²OS supported.

MB90820 Series

(4) 16-bit PPG timer (1 channel)

The 16-bit PPG timer 0 is used to provide a PPG signal for waveform generator. (See section “6. 16-bit PPG Timer”.)

(5) Waveform generator module

The waveform generator consists of three 16-bit timer registers, three 16-bit timer control registers and a waveform control register.

With waveform generator, it is possible to generate real time output, 16-bit PPG waveform output, non-overlap 3-phase waveform output for inverter control and DC chopper waveform output.

- It is possible to generate a non-overlap waveform output based on dead-time of 16-bit timer. (Dead-time timer function)
- It is possible to generate a non-overlap waveform output when realtime output is operated in 2-channel mode. (Dead-time timer function)
- By detecting realtime output compare match, GATE signal of the PPG timer operation will be generated to start or stop PPG timer operation. (GATE function)
- When a match is detected by real time output compare, the 16-bit timer is activated. The PPG timer can be started or stopped easily by generating a GATE signal for PPG operation until the 16-bit timer stops. (GATE function)
- Force to stop output waveform using DTTI pin input.
- Interrupt is generated when DTTI active or 16-bit timer underflow.
- EI²OS is supported.

(6) Register configuration

- 16-bit free-running timer registers

Timer Control Status Register (Upper)									
	15	14	13	12	11	10	9	8	⇐ Bit
Address: 00005F _H	ECKE	IRQZF	IRQZE	MSI2	MSI1	MSI0	ICLR	ICRE	TCCSH
Read/write ⇐	R/W	R/W	R/W	R/W	R/W	R/W	R/W	R/W	
Initial value ⇐	0	0	0	0	0	0	0	0	
Timer Control Status Register (Lower)									
	7	6	5	4	3	2	1	0	⇐ Bit
Address: 00005E _H	—	BFE	STOP	MODE	SCLR	CLK2	CLK1	CLK0	TCCSL
Read/write ⇐	—	R/W	R/W	R/W	R/W	R/W	R/W	R/W	
Initial value ⇐	X	0	1	0	0	0	0	0	
Timer Data Register (Upper)									
	15	14	13	12	11	10	9	8	⇐ Bit
Address: 00005D _H	T15	T14	T13	T12	T11	T10	T09	T08	TCDT
Read/write ⇐	R/W	R/W	R/W	R/W	R/W	R/W	R/W	R/W	
Initial value ⇐	0	0	0	0	0	0	0	0	
Timer Data Register (Lower)									
	7	6	5	4	3	2	1	0	⇐ Bit
Address: 00005C _H	T07	T06	T05	T04	T03	T02	T01	T00	TCDT
Read/write ⇐	R/W	R/W	R/W	R/W	R/W	R/W	R/W	R/W	
Initial value ⇐	0	0	0	0	0	0	0	0	

(Continued)

(Continued)

Compare Clear Buffer Register / Compare Clear Register (Upper)									
	15	14	13	12	11	10	9	8	Bit
Address: 00005B _H	CL15	CL14	CL13	CL12	CL11	CL10	CL09	CL08	CPCLR _B /CPCLR
Read/write ⇨	R/W	R/W	R/W	R/W	R/W	R/W	R/W	R/W	
Initial value ⇨	1	1	1	1	1	1	1	1	

Compare Clear Buffer Register / Compare Clear Register (Lower)									
	7	6	5	4	3	2	1	0	Bit
Address: 00005A _H	CL07	CL06	CL05	CL04	CL03	CL02	CL01	CL00	CPCLR _B /CPCLR
Read/write ⇨	R/W	R/W	R/W	R/W	R/W	R/W	R/W	R/W	
Initial value ⇨	1	1	1	1	1	1	1	1	

Note : Registers TCDT, CPCLR_B/CPCLR are word access only.

• Output compare registers

Compare Control Register (Upper)									
	15	14	13	12	11	10	9	8	Bit
Address: ch1 00007D _H ch3 00007F _H ch5 000081 _H	—	BTS1	BTS0	CMOD	OTE1	OTE0	OTD1	OTD0	OCS1/3/5
Read/write ⇨	—	R/W	R/W	R/W	R/W	R/W	R/W	R/W	
Initial value ⇨	X	1	1	0	0	0	0	0	

Compare Control Register (Lower)									
	7	6	5	4	3	2	1	0	Bit
Address: ch0 00007C _H ch2 00007E _H ch4 000080 _H	IOP1	IOP0	IOE1	IOE0	BUF1	BUF0	CST1	CST0	OCS0/2/4
Read/write ⇨	R/W	R/W	R/W	R/W	R/W	R/W	R/W	R/W	
Initial value ⇨	0	0	0	0	1	1	0	0	

Output Compare Buffer Register / Output Compare Register (Upper)									
	15	14	13	12	11	10	9	8	Bit
Address: ch0 000071 _H ch1 000073 _H ch2 000075 _H ch3 000077 _H ch4 000079 _H ch5 00007B _H	OP15	OP14	OP13	OP12	OP11	OP10	OP09	OP08	OCCPB0 to OCCPB5/ OCCP0 to OCCP5
Read/write ⇨	R/W	R/W	R/W	R/W	R/W	R/W	R/W	R/W	
Initial value ⇨	X	X	X	X	X	X	X	X	

Output Compare Buffer Register / Output Compare Register (Lower)									
	7	6	5	4	3	2	1	0	Bit
Address: ch0 000070 _H ch1 000072 _H ch2 000074 _H ch3 000076 _H ch4 000078 _H ch5 00007A _H	OP07	OP06	OP05	OP04	OP03	OP02	OP01	OP00	OCCPB0 to OCCPB5/ OCCP0 to OCCP5
Read/write ⇨	R/W	R/W	R/W	R/W	R/W	R/W	R/W	R/W	
Initial value ⇨	X	X	X	X	X	X	X	X	

Note : Register OCCPB0 to OCCPB5/OCCP0 to OCCP5 are word access only.

MB90820 Series

• Input capture registers

Input Capture Control Status Register (2/3) (Upper)

	15	14	13	12	11	10	9	8	⇐ Bit
Address: 00006B _H	—	—	—	—	—	—	IEI3	IEI2	ICSH23
Read/write ⇨	—	—	—	—	—	—	R	R	
Initial value ⇨	X	X	X	X	X	X	0	0	

Input Capture Control Status Register (2/3) (Lower)

	7	6	5	4	3	2	1	0	⇐ Bit
Address: 00006A _H	ICP3	ICP2	ICE3	ICE2	EG31	EG30	EG21	EG20	ICSL23
Read/write ⇨	R/W	R/W	R/W	R/W	R/W	R/W	R/W	R/W	
Initial value ⇨	0	0	0	0	0	0	0	0	

PPG output control/ Input Capture Control Status Register (0/1) (Upper)

	15	14	13	12	11	10	9	8	⇐ Bit
Address: 000069 _H	PGEN5	PGEN4	PGEN3	PGEN2	PGEN1	PGEN0	IEI1	IEI0	PICSH01
Read/write ⇨	R/W	R/W	R/W	R/W	R/W	R/W	R	R	
Initial value ⇨	0	0	0	0	0	0	0	0	

Input Capture Control Status Register (0/1) (Lower)

	7	6	5	4	3	2	1	0	⇐ Bit
Address: 000068 _H	ICP1	ICP0	ICE1	ICE0	EG11	EG10	EG01	EG00	PICSL01
Read/write ⇨	R/W	R/W	R/W	R/W	R/W	R/W	R/W	R/W	
Initial value ⇨	0	0	0	0	0	0	0	0	

Input Capture Data Register (Upper)

Address: ch0 000061 _H ch1 000063 _H ch2 000065 _H ch3 000067 _H	15	14	13	12	11	10	9	8	⇐ Bit
	CP15	CP14	CP13	CP12	CP11	CP10	CP09	CP08	IPCP0 to IPCP3
Read/write ⇨	R	R	R	R	R	R	R	R	
Initial value ⇨	X	X	X	X	X	X	X	X	

Input Capture Data Register (Lower)

Address: ch0 000060 _H ch1 000062 _H ch2 000064 _H ch3 000066 _H	7	6	5	4	3	2	1	0	⇐ Bit
	CP07	CP06	CP05	CP04	CP03	CP02	CP01	CP00	IPCP0 to IPCP3
Read/write ⇨	R	R	R	R	R	R	R	R	
Initial value ⇨	X	X	X	X	X	X	X	X	

Note : Registers IPCP0 to IPCP3 are word access only.

• Waveform generator registers

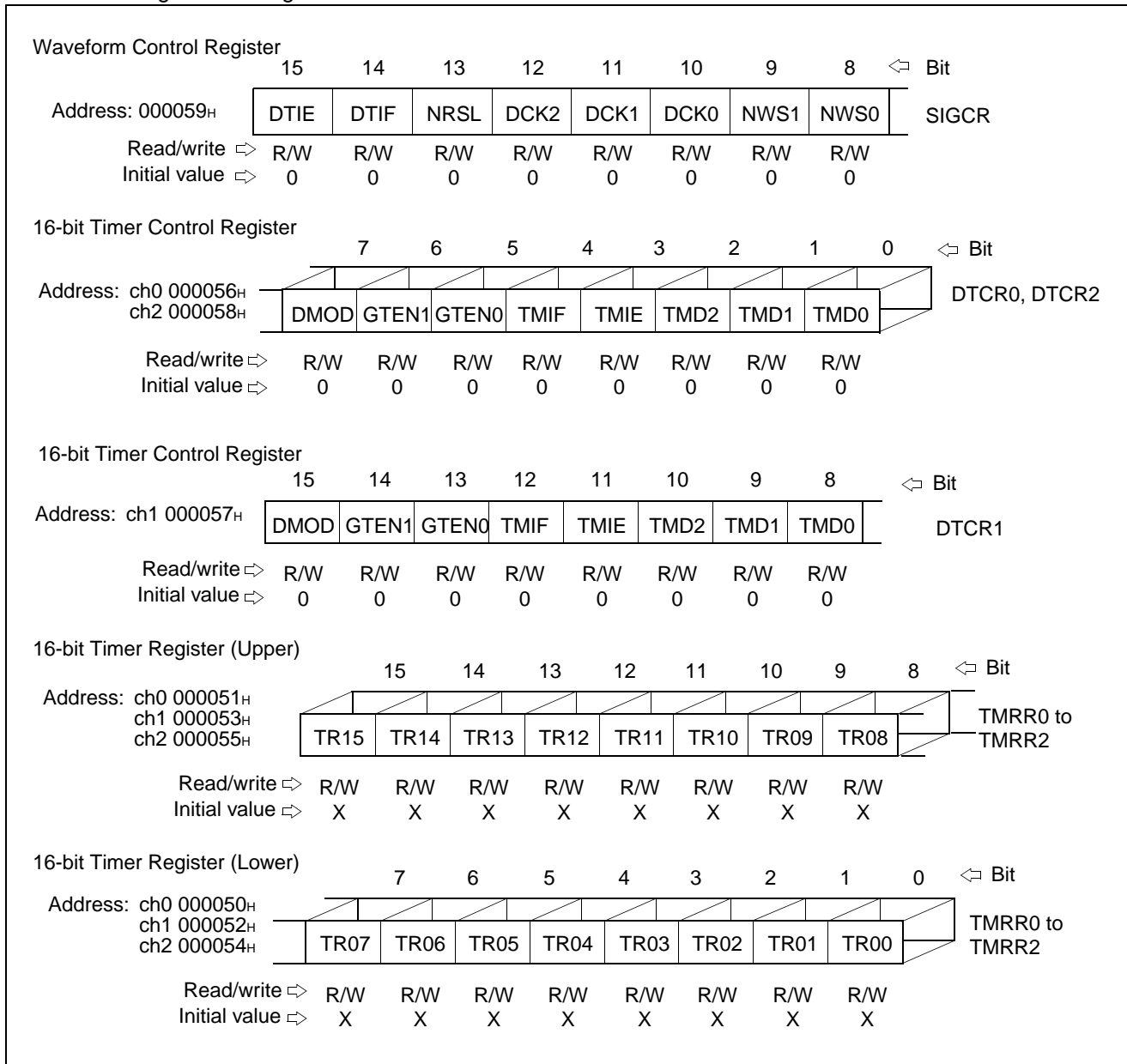

Note : Registers TMRR0 to TMRR2 are word access only.

MB90820 Series

(7) Block diagram

- Block diagram of Multi-functional timer

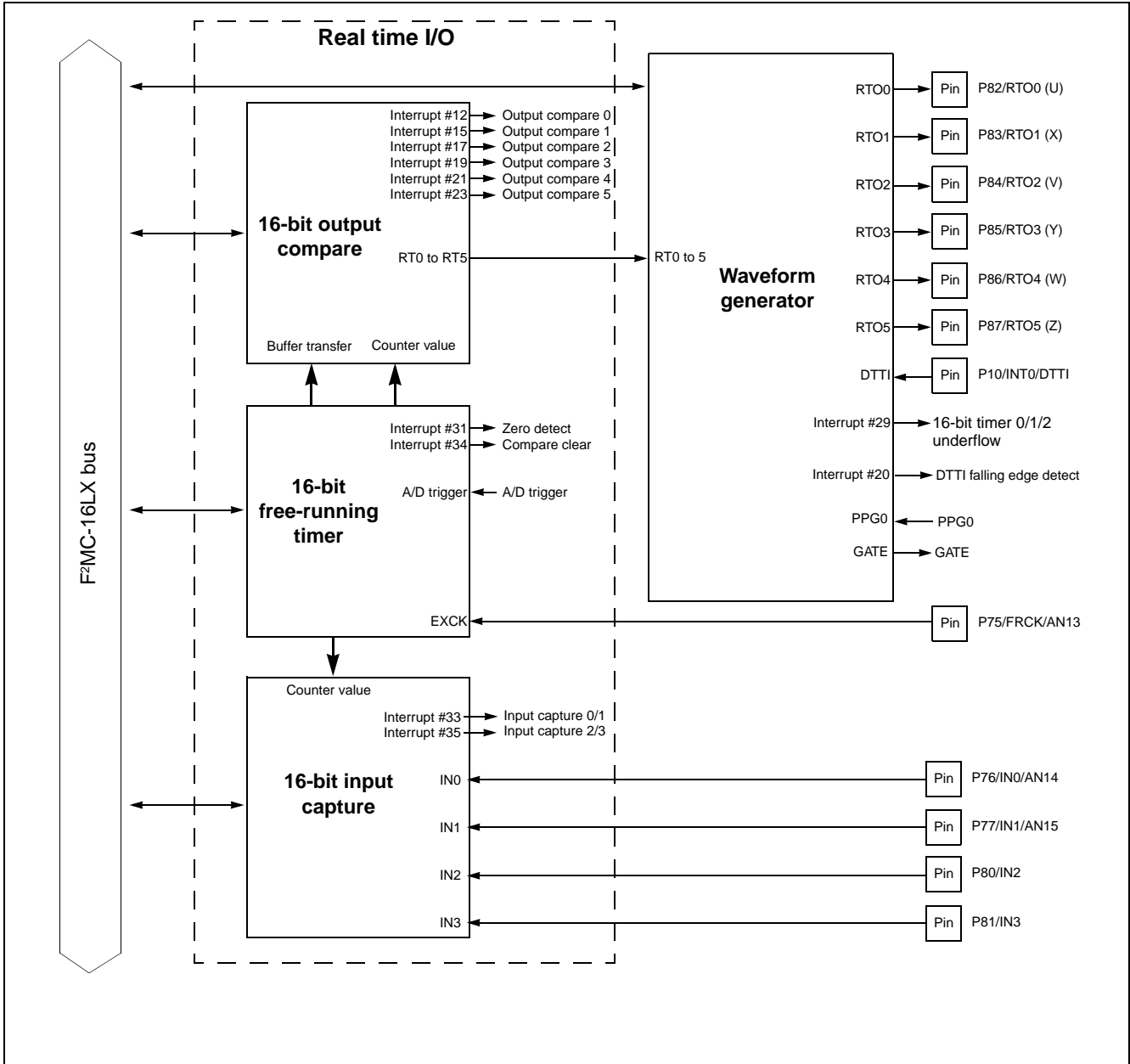

• Block diagram of 16-bit free-running timer

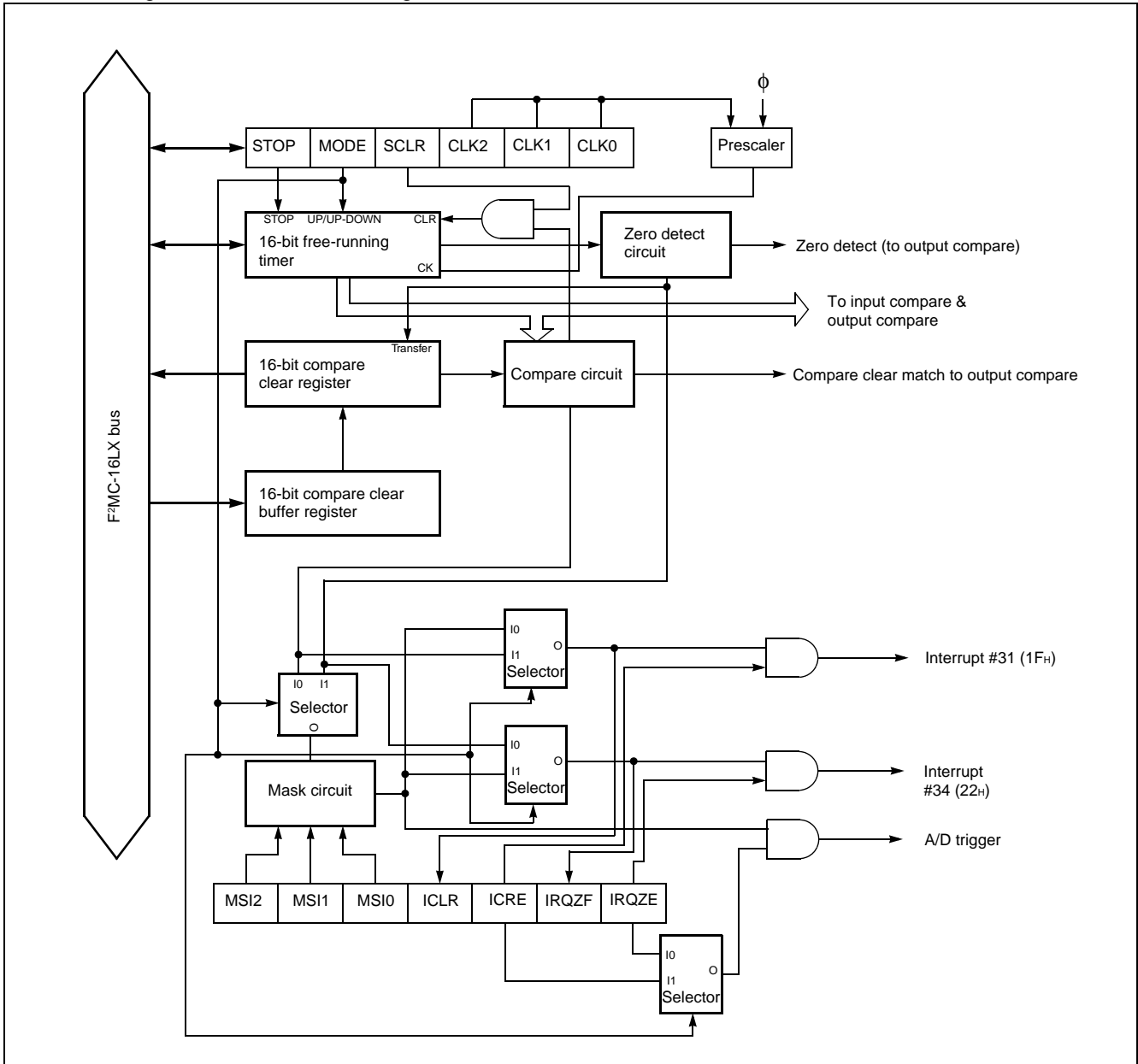

MB90820 Series

• Block diagram of 16-bit output compare

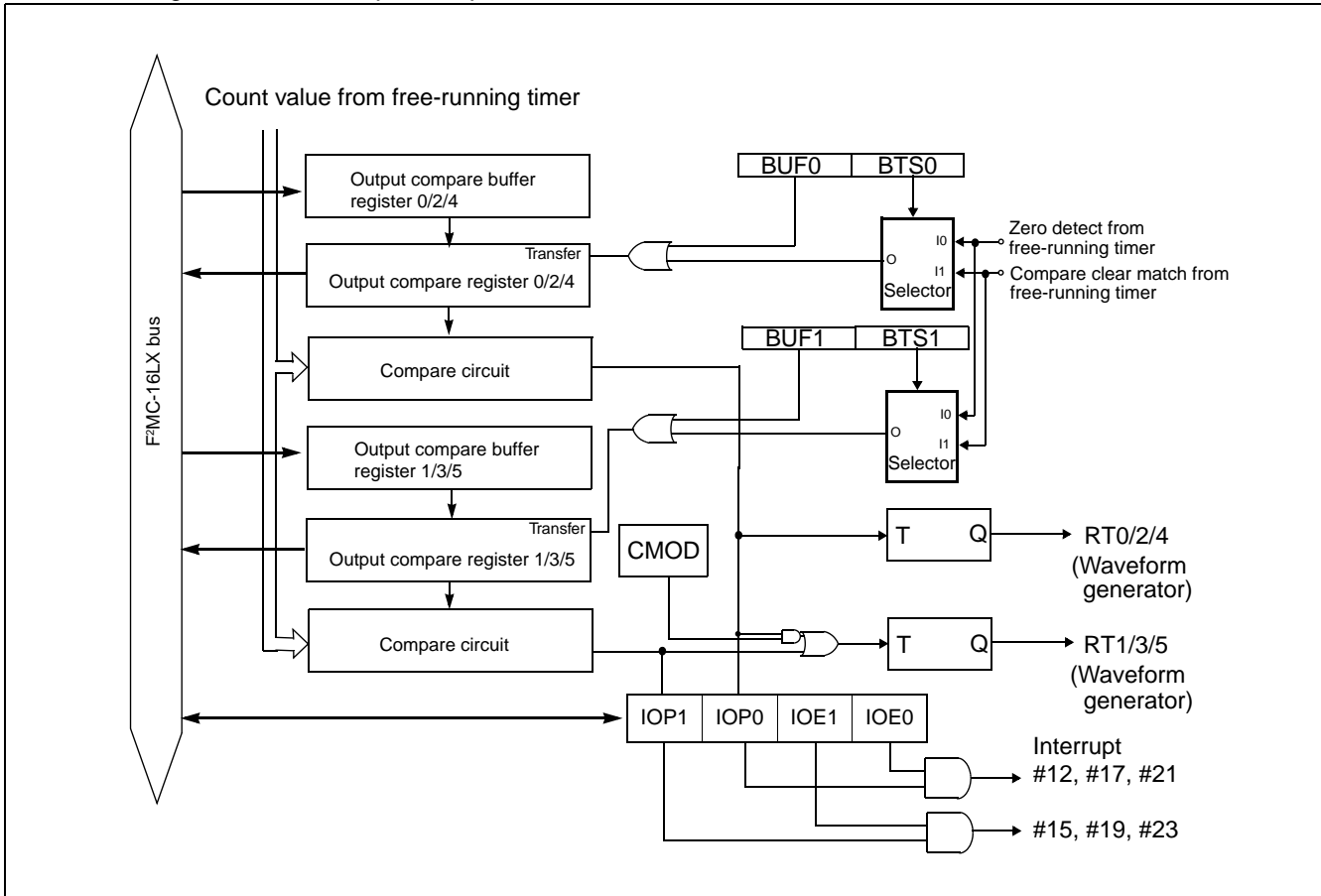

• Block diagram of 16-bit input capture

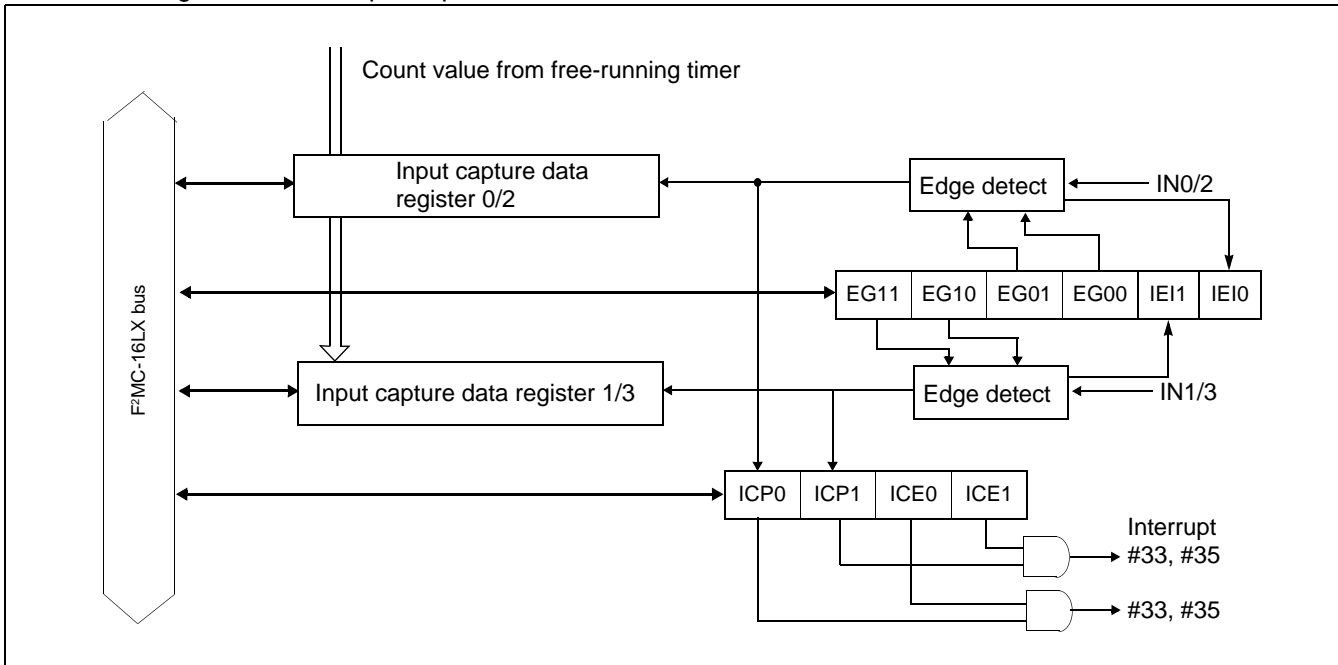

• Block diagram of waveform generator

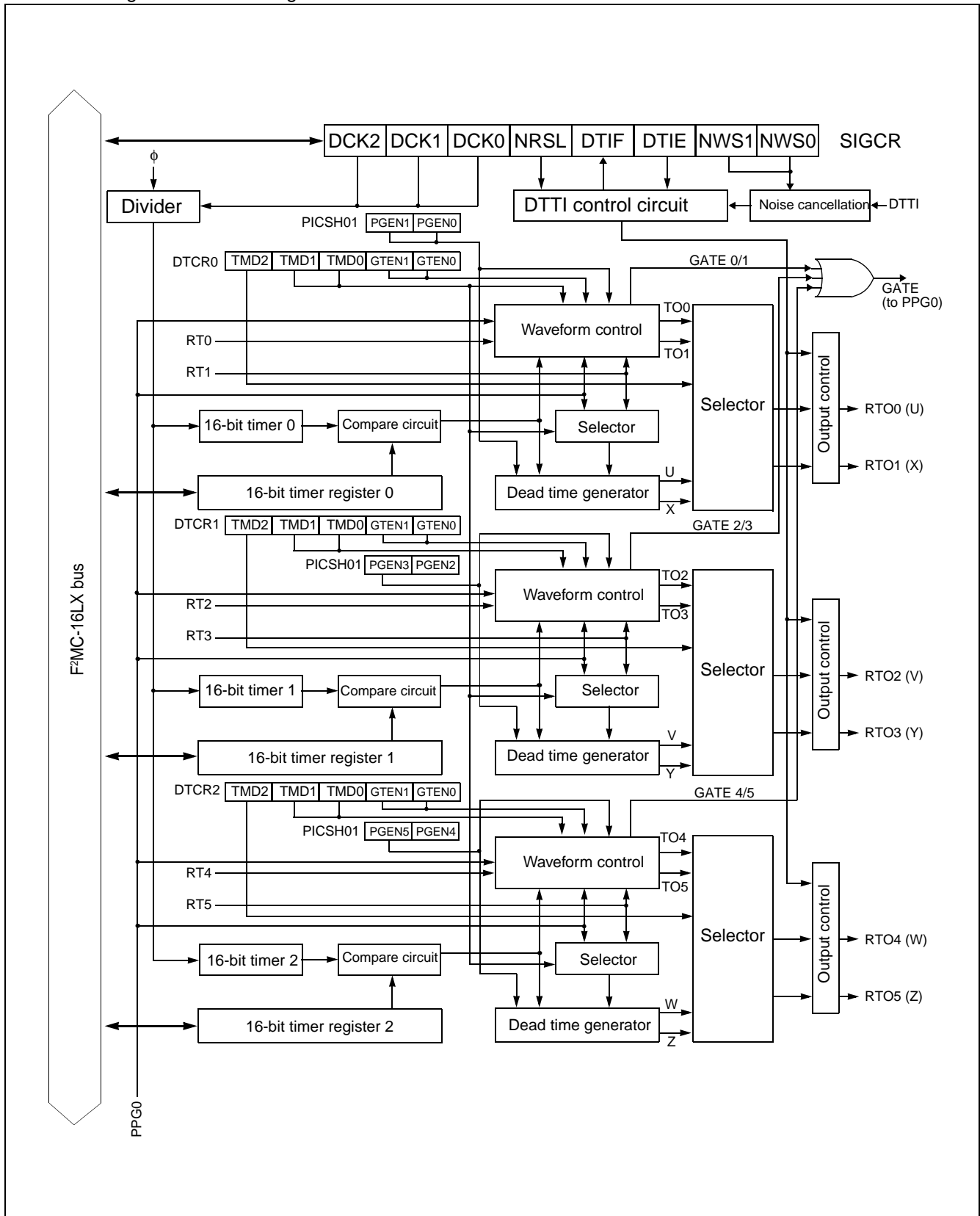

MB90820 Series

8. PWC Timer (x 2)

The PWC (pulse width count) timer is a 16-bit multi-functional up counter with reload timer functions and input signal pulse width count functions.

The PWC timer consists of a 16-bit counter, an input pulse divider, a division ratio control register, a count input pin, a pulse output pin, and a 16-bit control register.

The PWC timer has the following features:

- Interruption is generated when timer overflow or end of PWC measurement.
- EI²OS is supported.
- Timer functions :
 - Generates an interrupt request at set time intervals.
 - Outputs pulse signals synchronized with the timer cycle.
 - Selects the counter clock from three internal clocks.
- Pulse-width count functions:
 - Counts the time between external pulse input events.
 - Selects the counter clock from three internal clocks.
 - Count mode:
 - H pulse width (rising edge to falling edge) / L pulse width (falling edge to rising edge)
 - Rising-edge cycle (rising edge to falling edge) / Falling-edge cycle (falling edge to rising edge)
 - Count between edges (rising or falling edge to falling or rising edge)

Capable of counting cycles by dividing input pulses by 2², 2⁴, 2⁶, 2⁸ using an 8-bit input divider.

Generates an interrupt request upon the completion of count operation.

Selects single or consecutive count operation.

(1) Register configuration

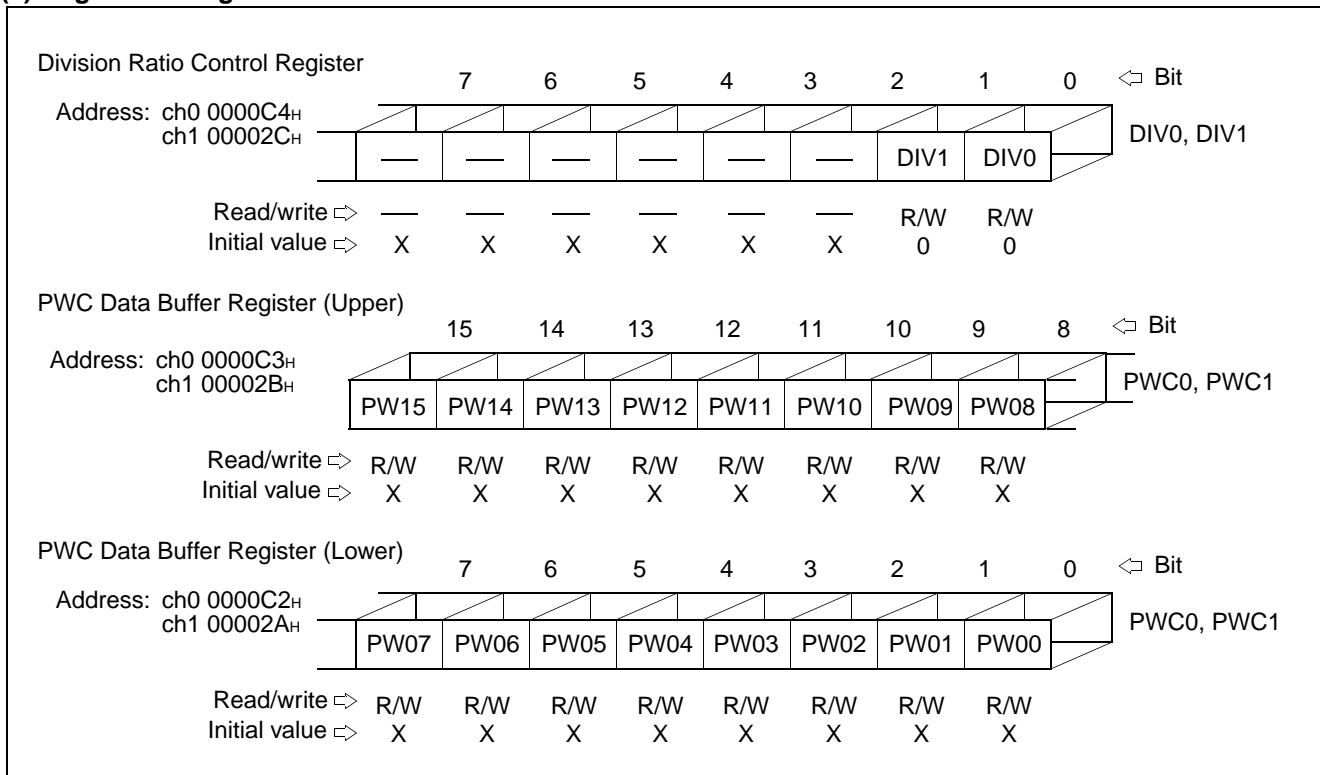

Note : Registers PWC0 to PWC1 are word access only.

(Continued)

(Continued)

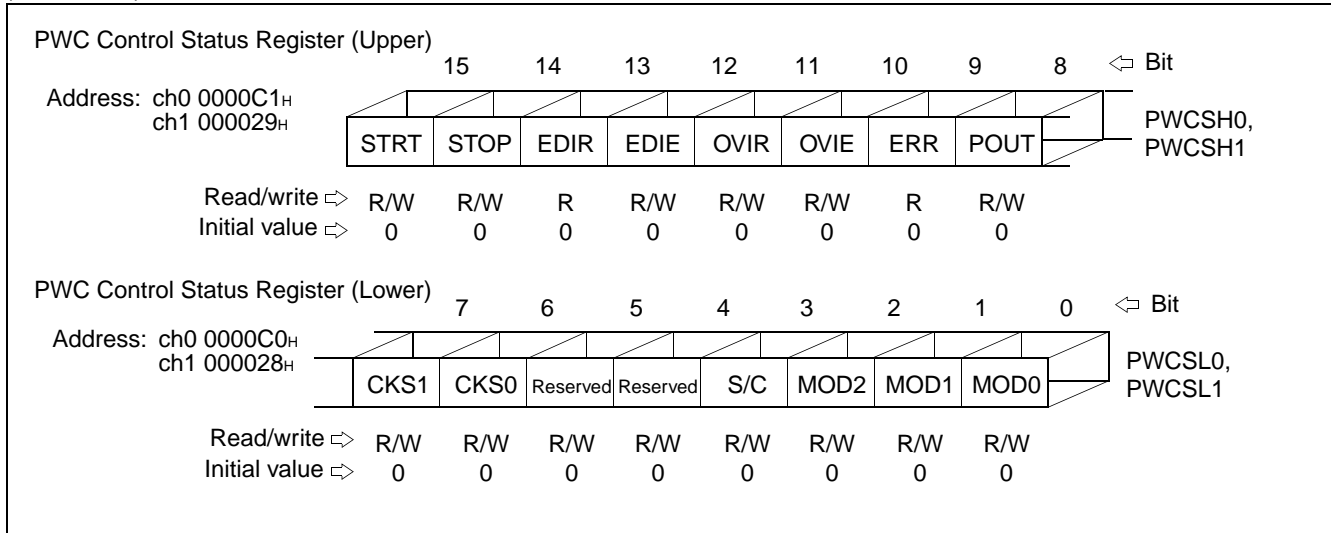

Note : Registers PWC0 to PWC1 are word access only.

(2) Block diagram

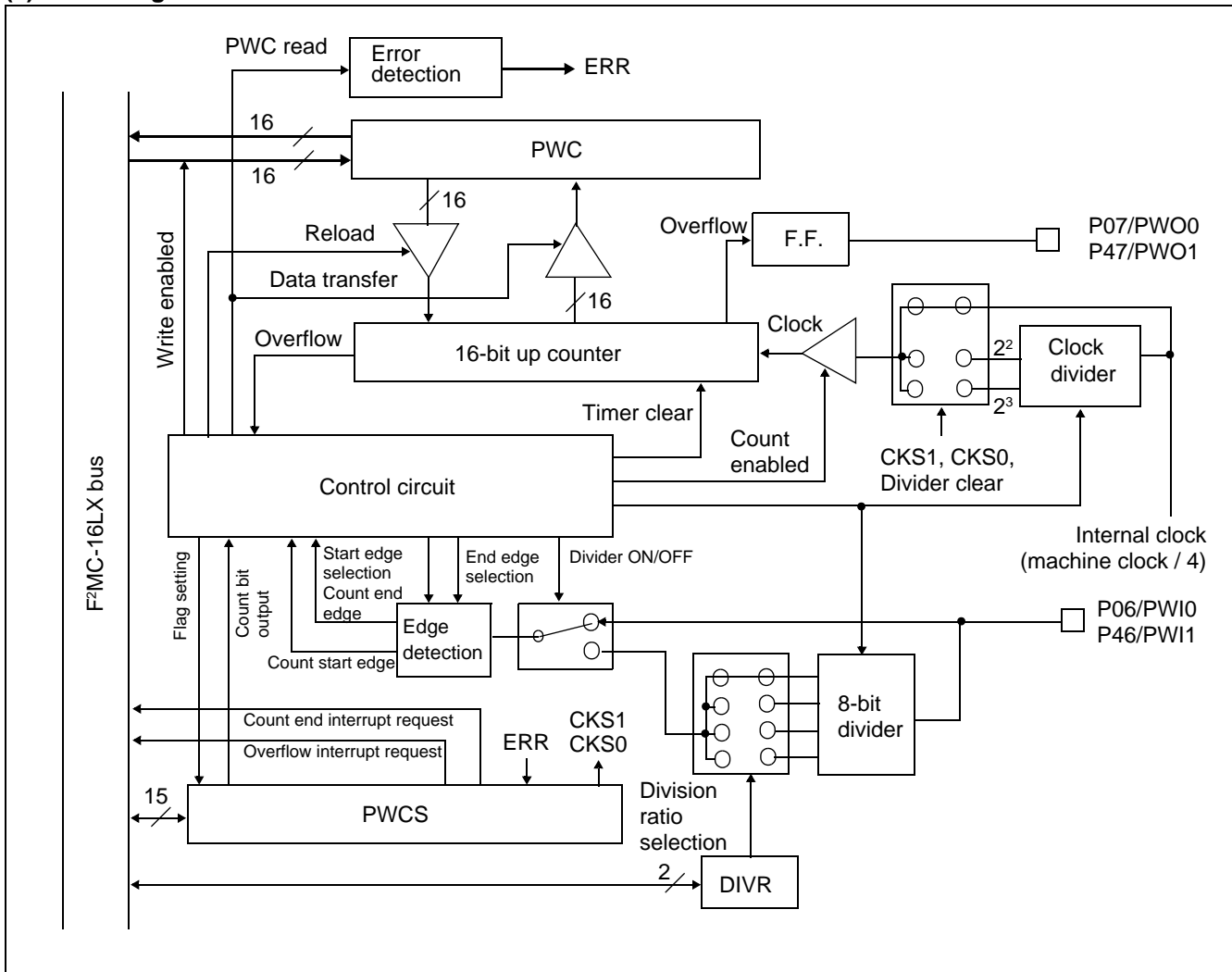

MB90820 Series

9. UART (x 2)

The UART is a serial I/O port for asynchronous (start-stop) communication or clock-synchronous communication. The UART has the following features :

- Full-duplex double buffering
- Capable of asynchronous (start-stop bit) and CLK-synchronous communications
- Support for the multiprocessor mode
- Various method of baud rate generation :
 - External clock input possible
 - Internal clock (a clock supplied from 16-bit reload timer can be used.)
 - Embedded dedicated baud rate generator

Operation	Baud rate
Asynchronous	31250/9615/4808/2404/1202 bps
CLK synchronous	2 M/1 M/500 K/250 K/125 K/62.5K bps

Note : Assuming internal machine clock frequencies of 6 MHz, 8 MHz, 10 MHz, 12 MHz, and 16 MHz.

- Error detection functions (parity, framing, overrun)
- NRZ (Non Return to Zero) signal format
- Interrupt request :
 - Receive interrupt (receive complete, receive error detection)
 - Transmit interrupt (transmission complete)
 - Transmit / receive conforms to extended intelligent I/O service (EI²OS).

(1) Register configuration

Serial Status Register

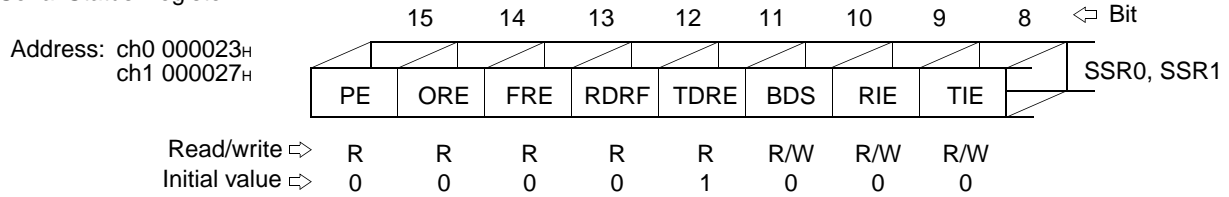

Serial Input Data Register / Serial Output Data Register

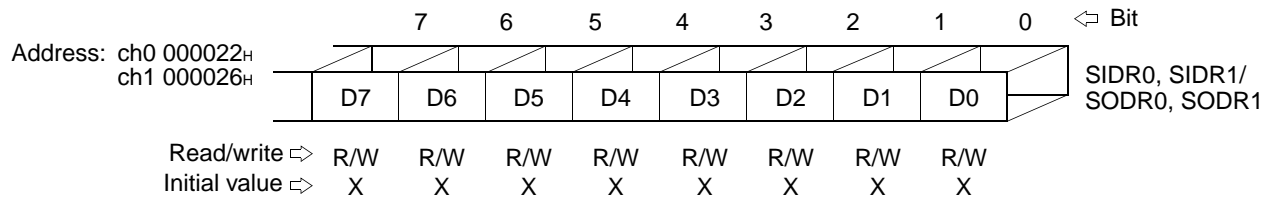

Serial Control Register

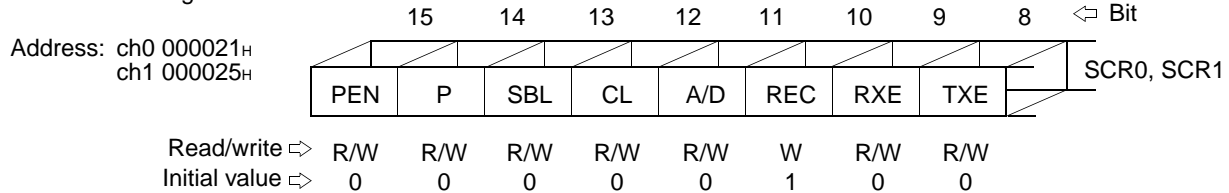

Serial Mode Register

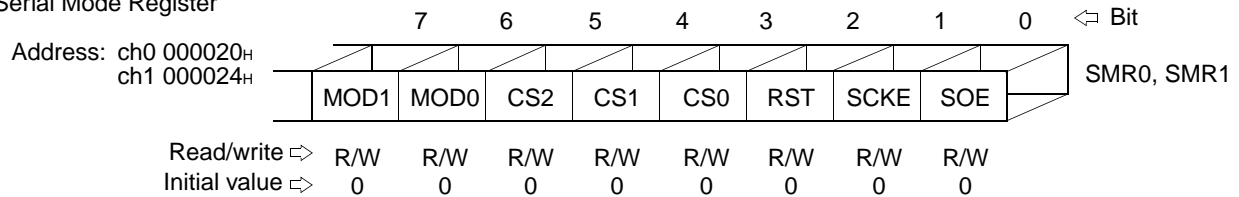

Clock Division Control Register

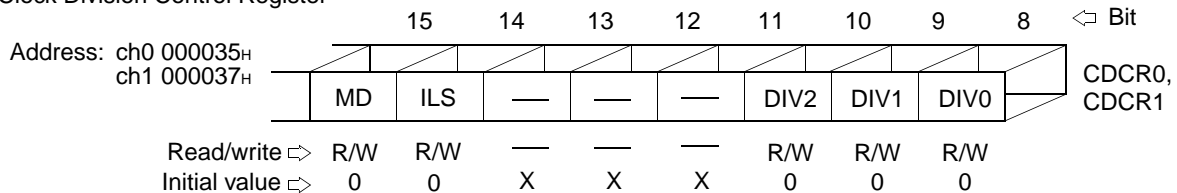

MB90820 Series

(2) Block diagram

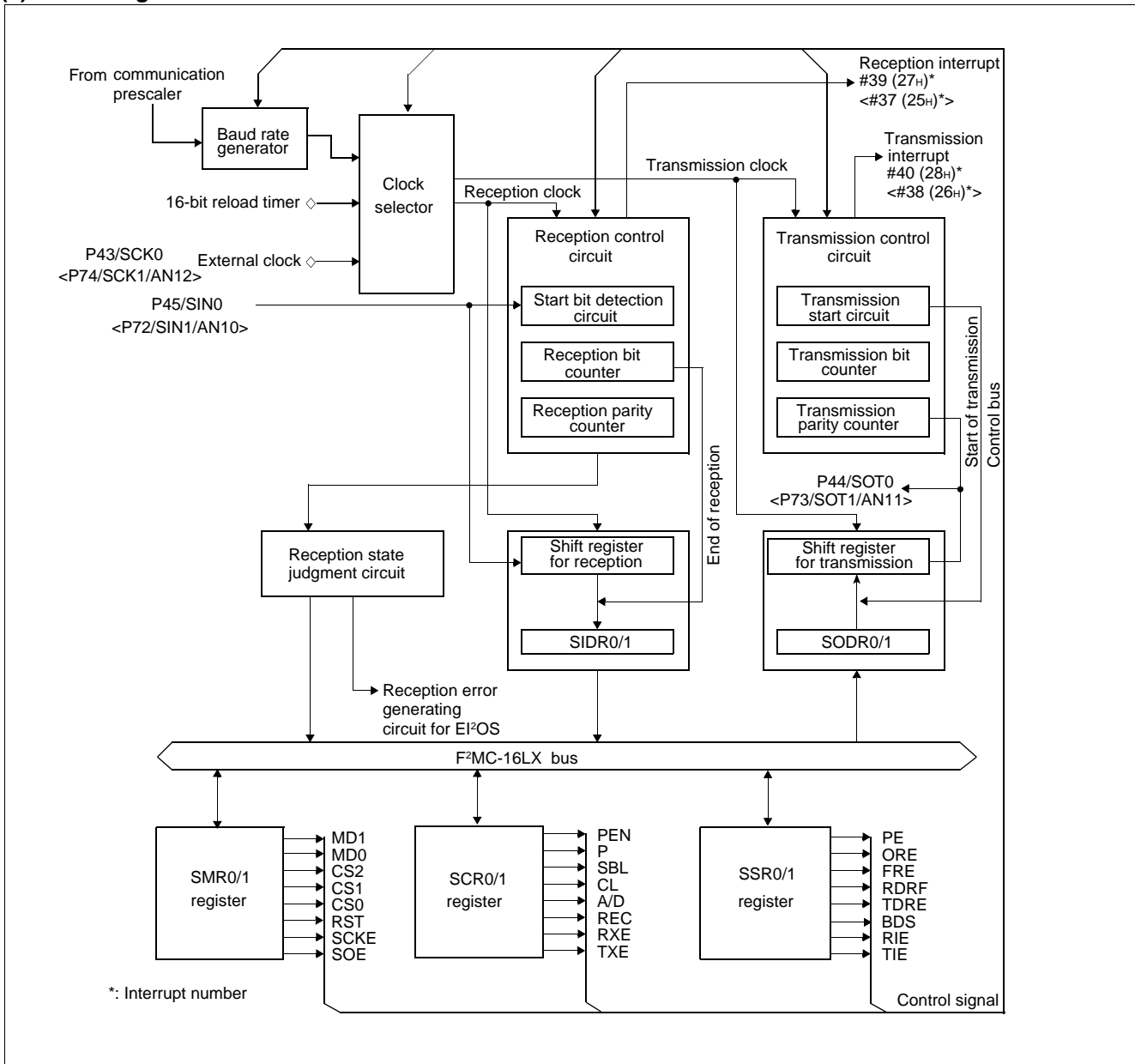

10. DTP/External Interrupts

The DTP/external interrupt circuit is activated by the signal supplied to a DTP/external interrupt pin. The CPU accepts the signal using the same procedure it uses for normal hardware interrupts and generates external interrupts or activates the extended intelligent I/O service (EI²OS).

Features of DTP/External Interrupt :

- Total 8 external interrupt channels.
- Two request levels (“H” and “L”) are provided for the intelligent I/O service.
- Four request levels (rising edge, falling edge, “H” level and “L” level) are provided for external interrupt requests.

(1) Register configuration

DTP/Interrupt Source Register									
	15	14	13	12	11	10	9	8	⇐ Bit
Address: 0000031 _H	ER7	ER6	ER5	ER4	ER3	ER2	ER1	ER0	EIRR
Read/write ⇨	R/W	R/W	R/W	R/W	R/W	R/W	R/W	R/W	
Initial value ⇨	0	0	0	0	0	0	0	0	
DTP/Interrupt Enable Register									
	7	6	5	4	3	2	1	0	⇐ Bit
Address: 000030 _H	EN7	EN6	EN5	EN4	EN3	EN2	EN1	EN0	ENIR
Read/write ⇨	R/W	R/W	R/W	R/W	R/W	R/W	R/W	R/W	
Initial value ⇨	0	0	0	0	0	0	0	0	
Request Level Setting Register (Upper)									
	15	14	13	12	11	10	9	8	⇐ Bit
Address: 0000033 _H	LB7	LA7	LB6	LA6	LB5	LA5	LB4	LA4	ELVRH
Read/write ⇨	R/W	R/W	R/W	R/W	R/W	R/W	R/W	R/W	
Initial value ⇨	0	0	0	0	0	0	0	0	
Request Level Setting Register (Lower)									
	7	6	5	4	3	2	1	0	⇐ Bit
Address: 000032 _H	LB3	LA3	LB2	LA2	LB1	LA1	LB0	LA0	ELVRL
Read/write ⇨	R/W	R/W	R/W	R/W	R/W	R/W	R/W	R/W	
Initial value ⇨	0	0	0	0	0	0	0	0	

MB90820 Series

(2) Block diagram

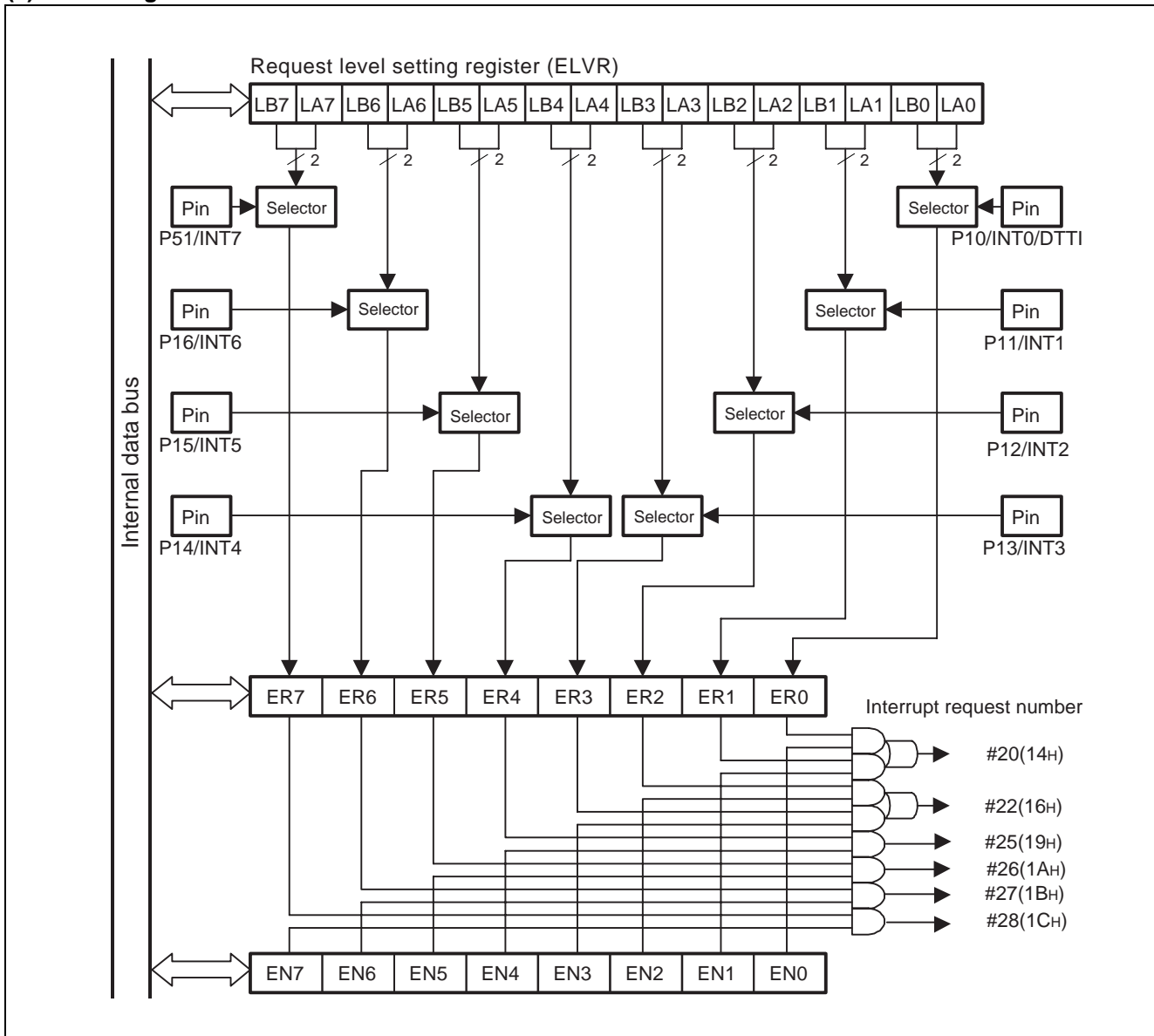

11. Delayed Interrupt Generation Module

The delayed interrupt generation module is used to generate a task switching interrupt. Interrupt requests to the F²MC-16LX CPU can be generated and cleared by software using this module.

(1) Register configuration

Delay interrupt cause/clear register								Bit	
Address: 00009F _H	15	14	13	12	11	10	9	8	
	—	—	—	—	—	—	—	R0	DIRR
Read/write ⇨	—	—	—	—	—	—	—	R/W	
Initial value ⇨	X	X	X	X	X	X	X	0	

(2) Block diagram

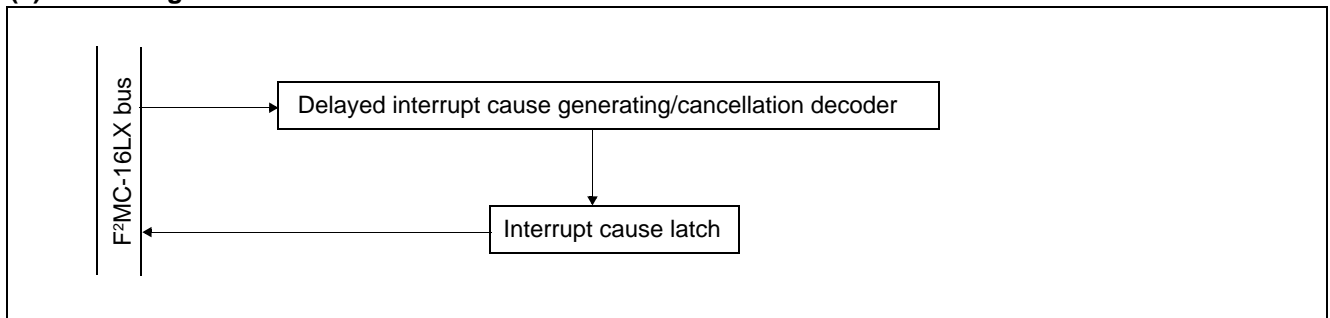

MB90820 Series

12. A/D Converter

The A/D converter converts the analog voltage input (input voltage) to an analog input pin to a digital value. It has the following features :

- The minimum conversion time is 3 μ s (for a machine clock of 24 MHz; including sampling time).
- The converter uses the RC-type successive approximation conversion method with a sample and hold circuit.
- A resolution of 10 bits or 8 bits can be set.
- Up to 16 channels for analog input pins can be selected by a program.
- Various conversion mode :
 - Single conversion mode : Selectively convert one channel.
 - Scan conversion mode : Continuously convert multiple channels. Maximum of 16 selectable channels.
 - Continuous conversion mode : Repeatedly convert specified channels.
 - Stop conversion mode : Convert one channel then halt until the next activation (enables synchronization of the conversion start timing).
- At the end of A/D conversion, an interrupt request can be generated and EI²OS can be activated.
- In the interrupt-enabled state, the conversion data protection function prevents any part of the data from being lost through continuous conversion.
- The conversion can be activated by software, 16-bit reload timer 1 (rising edge) and 16-bit free-running timer zero detection edge.

(1) Register configuration

A/D Control Status Register (upper)									
	15	14	13	12	11	10	9	8	Bit
Address: 00000C7 _H	BUSY	INT	INTE	PAUS	STS1	STS0	STRT	—	ADCS1
Read/write ⇨	R/W	R/W	R/W	R/W	R/W	R/W	W	—	
Initial value ⇨	0	0	0	0	0	0	0	X	
A/D Control Status Register (lower)									
	7	6	5	4	3	2	1	0	Bit
Address: 00000C6 _H	MD1	MD0	S10	—	—	—	—	Reserved	ADCS0
Read/write ⇨	R/W	R/W	R/W	—	—	—	—	—	
Initial value ⇨	0	0	0	X	X	X	X	0	
A/D Data Register (upper)									
	15	14	13	12	11	10	9	8	Bit
Address: 00000C9 _H	—	—	—	—	—	—	D9	D8	ADCR1
Read/write ⇨	—	—	—	—	—	—	R	R	
Initial value ⇨	X	X	X	X	X	X	X	X	
A/D Data Register (lower)									
	7	6	5	4	3	2	1	0	Bit
Address: 00000C8 _H	D7	D6	D5	D4	D3	D2	D1	D0	ADCR0
Read/write ⇨	R	R	R	R	R	R	R	R	
Initial value ⇨	X	X	X	X	X	X	X	X	

(Continued)

(Continued)

A/D Setting Register (upper)

	15	14	13	12	11	10	9	8	⇐ Bit
Address: 0000CB _H	ST2	ST1	ST0	CT2	CT1	CT0	Reserved	ANS3	ADSR1
Read/write ⇐	R/W	R/W	R/W	R/W	R/W	R/W	R/W	R/W	
Initial value ⇐	0	0	0	0	0	0	0	0	

A/D Setting Register (lower)

	7	6	5	4	3	2	1	0	⇐ Bit
Address: 0000CA _H	ANS2	ANS1	ANS0	Reserved	ANE3	ANE2	ANE1	ANE0	ADSR0
Read/write ⇐	R/W	R/W	R/W	R/W	R/W	R/W	R/W	R/W	
Initial value ⇐	0	0	0	0	0	0	0	0	

A/D Input Enable Register

	15	14	13	12	11	10	9	8	⇐ Bit
Address: 0000C5 _H	ADE7	ADE6	ADE5	ADE4	ADE3	ADE2	ADE1	ADE0	ADER0
Read/write ⇐	R/W	R/W	R/W	R/W	R/W	R/W	R/W	R/W	
Initial value ⇐	1	1	1	1	1	1	1	1	

A/D Input Enable Register

	7	6	5	4	3	2	1	0	⇐ Bit
Address: 0000D0 _H	ADE15	ADE14	ADE13	ADE12	ADE11	ADE10	ADE9	ADE8	ADER1
Read/write ⇐	R/W	R/W	R/W	R/W	R/W	R/W	R/W	R/W	
Initial value ⇐	1	1	1	1	1	1	1	1	

MB90820 Series

(2) Block diagram

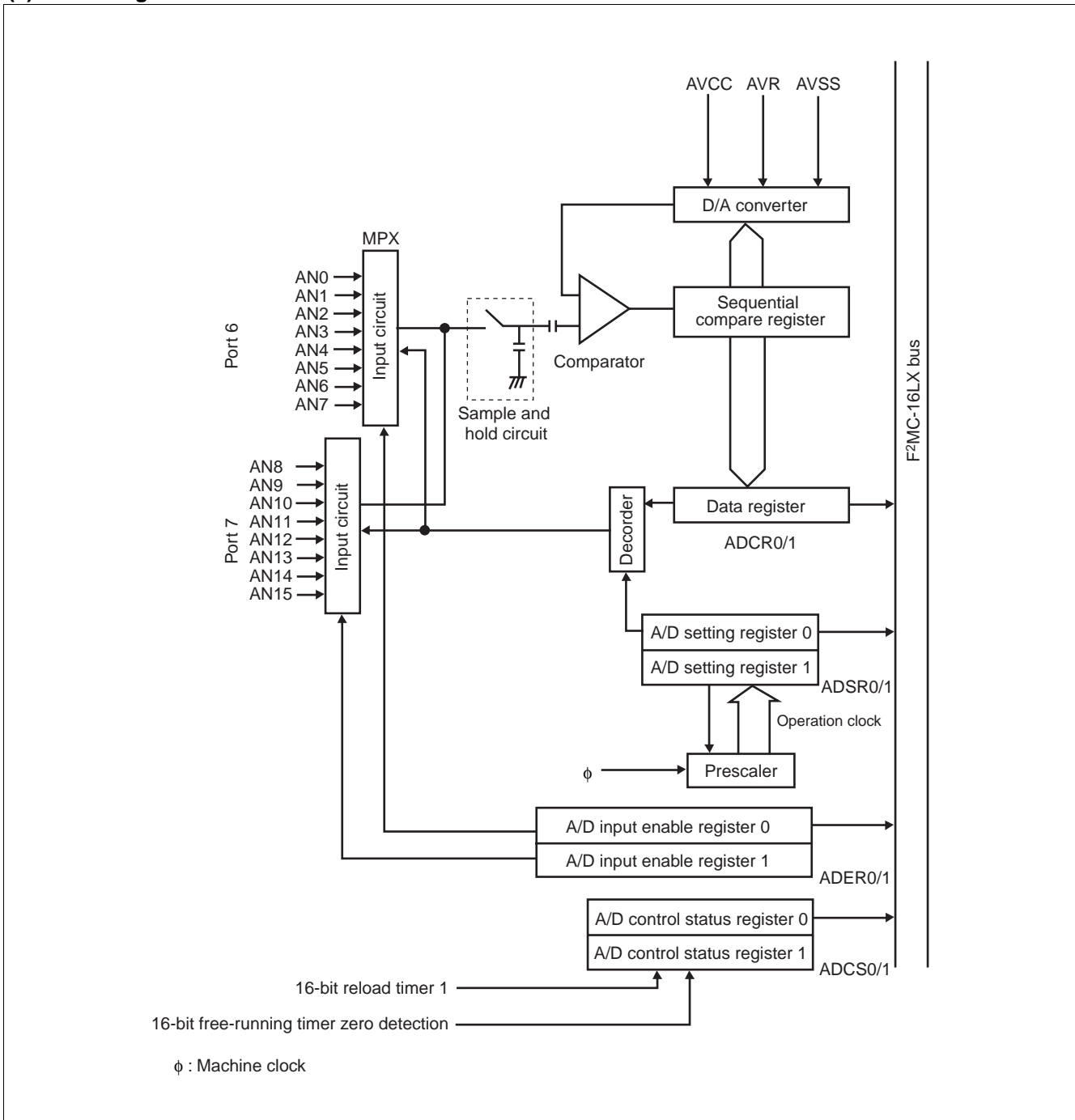

13. D/A Converter

The D/A converter is used to generate an analog output from an 8-bit digital input. By setting the enable bit in the D/A control register (DACR) to 1, it will enable the corresponding D/A output channel. Hence, setting this bit to 0 will disable that channel.

If D/A output is disabled, the analog switch inserted to the output of each D/A converter channel in series is turned off. In the D/A converter, the bit is cleared to 0 and the direct-current path is shut off. The above is also true in the stop mode.

The output voltage of the D/A converter ranges from 0 V to $255/256 \times AV_{CC}$. To change the output voltage range, adjust the AV_{CC} voltage externally.

The D/A converter output does not have the internal buffer amplifier. The analog switch (= 100 Ω) is inserted to the output in series. To apply load to the output externally, estimate a sufficient stabilization time.

Table below lists the theoretical values of output voltage of the D/A converter.

Value written to DA07 to DA00 and DA17 to DA10	Theoretical value of output voltage
00 _H	$0/256 \times AV_{CC} (= 0 \text{ V})$
01 _H	$1/256 \times AV_{CC}$
02 _H	$2/256 \times AV_{CC}$
:	:
FD _H	$253/256 \times AV_{CC}$
FE _H	$254/256 \times AV_{CC}$
FF _H	$255/256 \times AV_{CC}$

MB90820 Series

(1) Register configuration

D/A data register 1

Bit	15	14	13	12	11	10	9	8	
Address:0000CD _H	DA17	DA16	DA15	DA14	DA13	DA12	DA11	DA10	DAT1
Read/write →	R/W	R/W	R/W	R/W	R/W	R/W	R/W	R/W	
Initial value →	X	X	X	X	X	X	X	X	

D/A data register 0

Bit	7	6	5	4	3	2	1	0	
Address:0000CC _H	DA07	DA06	DA05	DA04	DA03	DA02	DA01	DA00	DAT0
Read/write →	R/W	R/W	R/W	R/W	R/W	R/W	R/W	R/W	
Initial value →	X	X	X	X	X	X	X	X	

D/A control register 1

Bit	15	14	13	12	11	10	9	8	
Address:0000CF _H	-	-	-	-	-	-	-	DAE1	DACR1
Read/write →	-	-	-	-	-	-	-	R/W	
Initial value →	X	X	X	X	X	X	X	0	

D/A control register 0

Bit	7	6	5	4	3	2	1	0	
Address:0000CE _H	-	-	-	-	-	-	-	DAE0	DACR0
Read/write →	-	-	-	-	-	-	-	R/W	
Initial value →	X	X	X	X	X	X	X	0	

(2) Block diagram

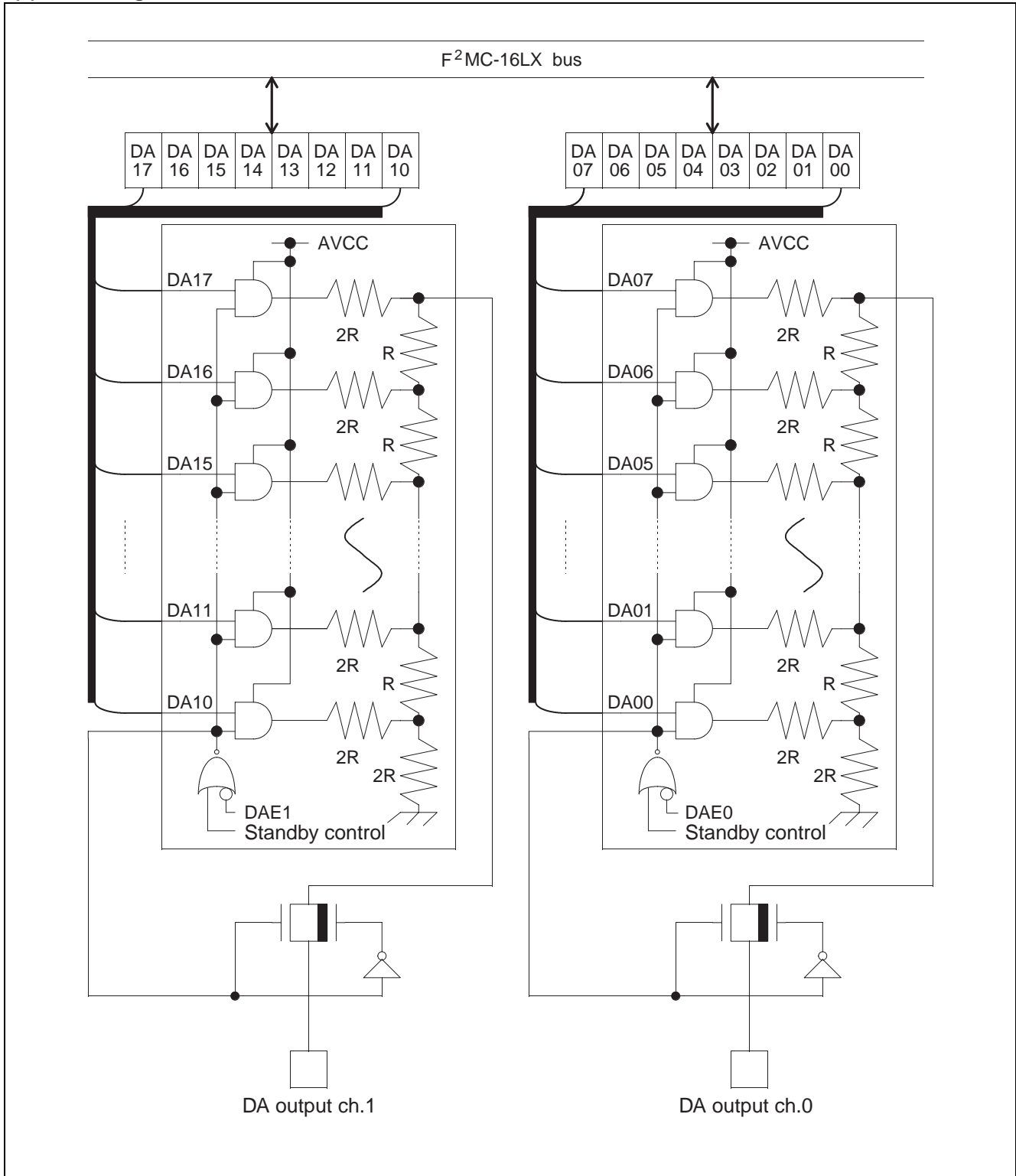

MB90820 Series

14. ROM Correction Function

When the corresponding address matches the value set in the address detection register, the instruction code to be loaded into the CPU is forced to be replaced with the INT9 instruction code (01H). When executing a set instruction, the CPU executes the INT9 instruction. The address detection function is implemented by processing using the INT9 instruction routine.

The device contains two address detection registers, each provided with a compare enable bit. When the value set in the address detection register matches an address and the interrupt enable bit is "1", the instruction code to be loaded into the CPU is forced to be replaced with the INT9 instruction code.

(1) Register configuration

Program Address Detection Control Status Register									
	7	6	5	4	3	2	1	0	⇐ Bit
Address: 00009EH	—	—	—	—	AD1E	AD1D	AD0E	AD0D	PADCSR
Read/write ⇐	—	—	—	—	R/W	R/W	R/W	R/W	
Initial value ⇐	X	X	X	X	0	0	0	0	
Program Address Detection Register 0 (Upper Byte)									
	7	6	5	4	3	2	1	0	⇐ Bit
Address: 001FF2H									PADRH0
Read/write ⇐	R/W	R/W	R/W	R/W	R/W	R/W	R/W	R/W	
Initial value ⇐	X	X	X	X	X	X	X	X	
Program Address Detection Register 0 (Middle Byte)									
	15	14	13	12	11	10	9	8	⇐ Bit
Address: 001FF1H									PADRM0
Read/write ⇐	R/W	R/W	R/W	R/W	R/W	R/W	R/W	R/W	
Initial value ⇐	X	X	X	X	X	X	X	X	
Program Address Detection Register 0 (Lower Byte)									
	7	6	5	4	3	2	1	0	⇐ Bit
Address: 001FF0H									PADRL0
Read/write ⇐	R/W	R/W	R/W	R/W	R/W	R/W	R/W	R/W	
Initial value ⇐	X	X	X	X	X	X	X	X	
Program Address Detection Register 1 (Upper Byte)									
	15	14	13	12	11	10	9	8	⇐ Bit
Address: 001FF5H									PADRH1
Read/write ⇐	R/W	R/W	R/W	R/W	R/W	R/W	R/W	R/W	
Initial value ⇐	X	X	X	X	X	X	X	X	

(Continued)

(Continued)

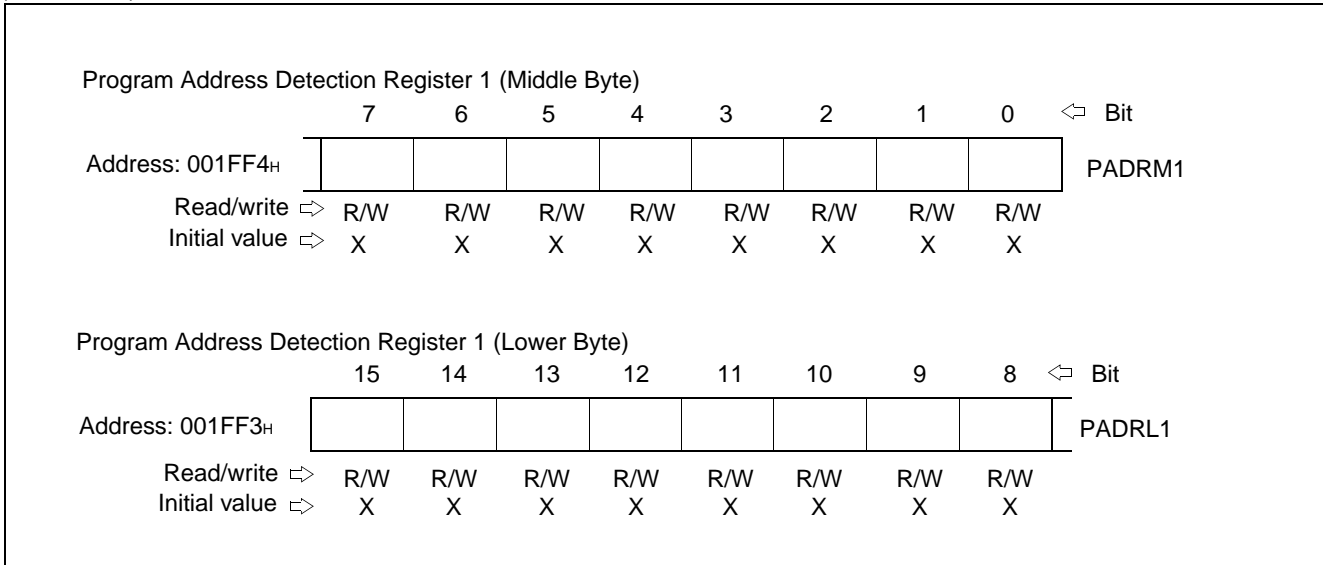

(2) Block diagram

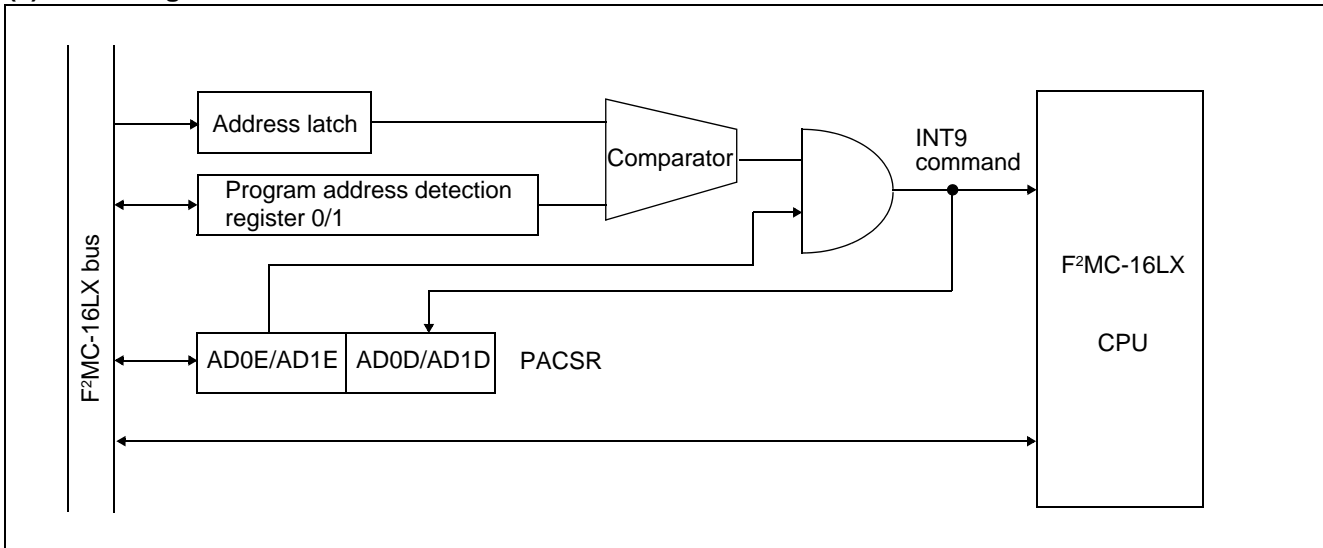

MB90820 Series

15. ROM Mirroring Function Selection Module

The ROM mirror function selection module sets the data in ROM assigned to FF bank so that the data is read by access to 00 bank.

(1) Register configuration

ROM Mirror Function Selection Register									
	15	14	13	12	11	10	9	8	Bit
Address : 00006FH	—	—	—	—	—	—	—	M1	ROMM
Read/write	—	—	—	—	—	—	—	R/W	
Initial value	X	X	X	X	X	X	X	1	

(2) Block diagram

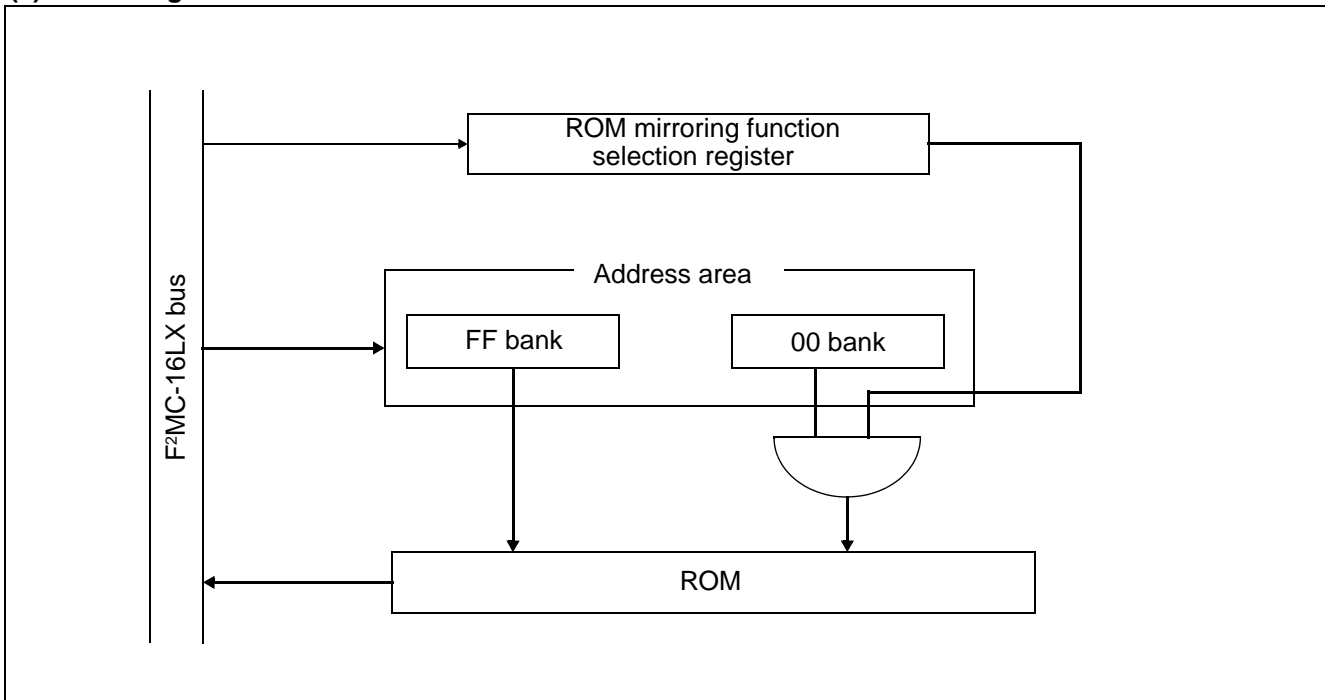

16. 512/1024 Kbit Flash Memory

The 512K bits flash memory is allocated in the FF_H banks on the CPU memory map.

The 1024K bits flash memory is allocated in the FE_H and FF_H banks on the CPU memory map.

Like MaskROM, flash memory is read-accessible and program-accessible to the CPU using the flash memory interface circuit. The flash memory can be programmed/erased by the instruction from the CPU via the flash memory interface circuit. The flash memory can therefore be reprogrammed (updated) while still on the circuit board under integrated CPU control, allowing program code and data to be improved efficiently.

Note that sector operations such as “enable sector protect” cannot be used.

Features of 512/1024K bits flash memory

- 64K x 8 bits/32K x 16 bits (32K + 8K x 2 + 16K) sector configuration for 512K bits flash memory
- 128K x 8 bits/64K x 16 bits (64K + 32K + 8K x 2 + 16K) sector configuration for 1024K bits flash memory
- Automatic program algorithm (same as the Embedded Algorithm* : MBM29F400TA)
- Installation of the deletion temporary stop/delete restart function
- Write/delete completion detected by the data polling or toggle bit
- Write/delete completion detected by the CPU interrupt
- Compatibility with the JEDEC standard-type command
- Each sector deletion can be executed (sectors can be freely combined)
- Flash security function
- Number of write/delete operations are guaranteed 10,000 times.

* : Embedded Algorithm is a trademark of Advanced Micro Devices, Inc.

(1) Register configuration

Flash Memory Control Status Register									Bit number
	7	6	5	4	3	2	1	0	
Address: 0000AE _H	INTE	RDYINT	WE	RDY	Reserved	Reserved	Reserved	Reserved	FMCS
Read/write ⇔	R/W	R/W	R/W	R	—	—	—	—	
Initial value ⇔	0	0	0	X	0	0	0	0	

MB90820 Series

(2) Sector configuration of flash memory

The flash memory has the sector configuration illustrated below. The addresses in the illustration are the upper and lower addresses of each sector.

When 512K bits flash memory is accessed from the CPU, SA0 to SA3 are allocated in the FF bank.

Flash memory	CPU address	*Writer address
SA3 (16K bytes)	FFFFFF _H	7FFFF _H
	FFC000 _H	7C000 _H
SA2 (8K bytes)	FFBFFF _H	7BFFF _H
	FFA000 _H	7A000 _H
SA1 (8K bytes)	FF9FFF _H	79FFF _H
	FF8000 _H	78000 _H
SA0 (32K bytes)	FF7FFF _H	77FFF _H
	FF0000 _H	70000 _H

When 1024K bits flash memory is accessed from the CPU, SA0 to SA4 are allocated in the FE and FF bank.

Flash memory	CPU address	*Writer address
SA4 (16K bytes)	FFFFFF _H	7FFFF _H
	FFC000 _H	7C000 _H
SA3 (8K bytes)	FFBFFF _H	7BFFF _H
	FFA000 _H	7A000 _H
SA2 (8K bytes)	FF9FFF _H	79FFF _H
	FF8000 _H	78000 _H
SA1 (32K bytes)	FF7FFF _H	77FFF _H
	FF0000 _H	70000 _H
SA0 (64K bytes)	FE7FFF _H	6FFFF _H
	FE0000 _H	60000 _H

* : The writer address is the address to use instead of the CPU address when writing data from a parallel flash memory writer. Use the writer address when programming or erasing using a general-purpose parallel writer.

■ ELECTRICAL CHARACTERISTICS

1. Absolute Maximum Ratings

Parameter	Symbol	Rating		Unit	Remarks
		Min	Max		
Power supply voltage*1	V _{CC}	V _{SS} - 0.3	V _{SS} + 6.0	V	
	AV _{CC}	V _{SS} - 0.3	V _{SS} + 6.0	V	V _{CC} = AV _{CC} *2
	AVR	V _{SS} - 0.3	V _{SS} + 6.0	V	AV _{CC} ≥ AVR, AVR ≥ AV _{SS}
Input voltage*1	V _I	V _{SS} - 0.3	V _{SS} + 6.0	V	*3
Output voltage*1	V _O	V _{SS} - 0.3	V _{SS} + 6.0	V	*3
Maximum clamp current	I _{CLAMP}	- 2.0	+ 2.0	mA	*5
Total maximum clamp current	Σ I _{CLAMP}	—	20	mA	*5
“L” level maximum output current	I _{OL}	—	15	mA	*4
“L” level average output current	I _{OLAV1}	—	4	mA	Except for P00 to P07, P82 to P87
	I _{OLAV2}	—	12	mA	P00 to P07, P82 to P87
“L” level total maximum output current	ΣI _{OL}	—	100	mA	
“L” level total average output current	ΣI _{OLAV}	—	50	mA	
“H” level maximum output current	I _{OH}	—	-15	mA	*4
“H” level average output current	I _{OHAV}	—	-4	mA	
“H” level total maximum output current	ΣI _{OH}	—	-100	mA	
“H” level total average output current	ΣI _{OHAV}	—	-50	mA	
Power consumption	P _D	—	430	mW	
Operating temperature	T _A	-40	+85	°C	
Storage temperature	T _{stg}	-55	+150	°C	

*1 : This parameter is based on V_{SS} = AV_{SS} = 0.0 V.

*2 : AV_{CC} must never exceed V_{CC} when the power is turned on.

*3 : V_I and V_O must never exceed V_{CC} + 0.3 V. However if the maximum current to/from an input is limited by some means with external components, the I_{CLAMP} rating supersedes the V_I rating.

*4 : The maximum output current is a peak value for a corresponding pin.

*5 : • Applicable to pins: P00 to P07, P10 to P17, P20 to P27, P30 to P37, P40 to P47, P50, P51, P80 to P87.
 • Use within recommended operating conditions.
 • Use at DC voltage (current).
 • The +B signal should always be applied a limiting resistance placed between the +B signal and the microcontroller.
 • The value of the limiting resistance should be set so that when the +B signal is applied the input current to the microcontroller pin does not exceed rated values, either instantaneously or for prolonged periods.
 • Note that when the microcontroller drive current is low, such as in the power saving modes, the +B input potential may pass through the protective diode and increase the potential at the V_{CC} pin, and this may affect other devices.

MB90820 Series

- Note that if a +B signal is input when the microcontroller power supply is off (not fixed at 0 V), the power supply is provided from the pins, so that incomplete operation may result.
- Note that if the +B input is applied during power-on, the power supply is provided from the pins and the resulting supply voltage may not be sufficient to operate the power-on reset.
- Care must be taken not to leave the +B input pin open.
- Note that analog system input/output pins (LCD drive pins and comparator input pins, etc.) other than the A/D input pins cannot accept +B input.
- Sample recommended circuits:

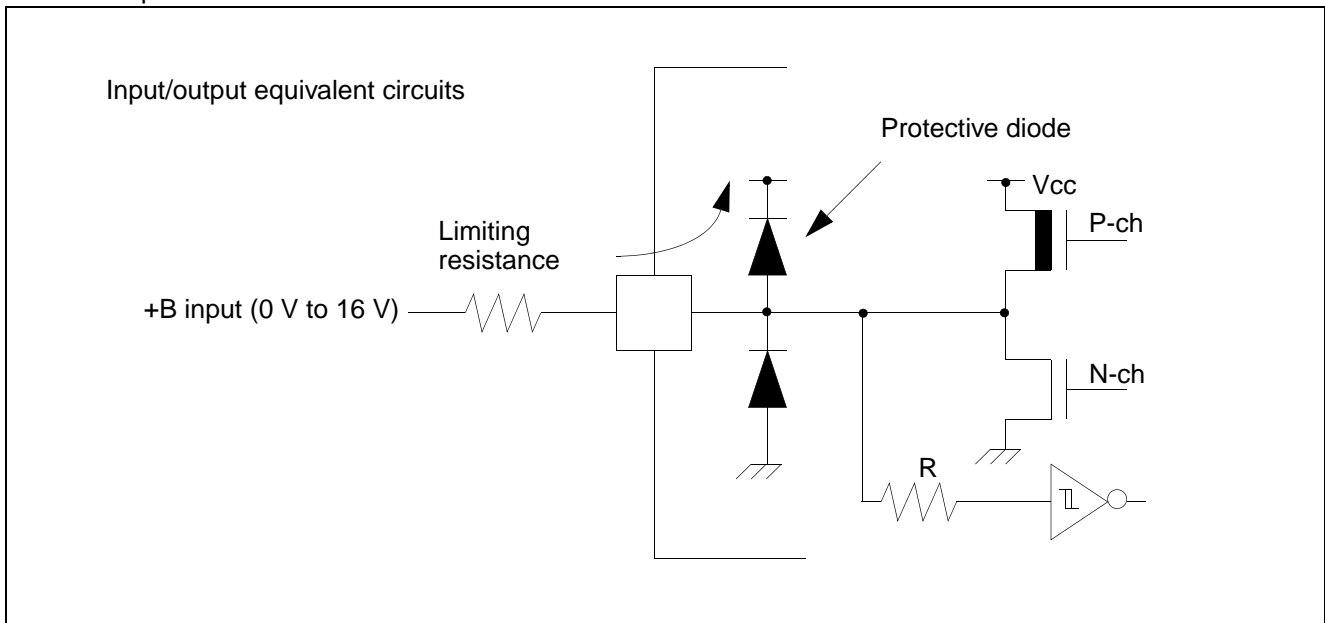

WARNING: Semiconductor devices can be permanently damaged by application of stress (voltage, current, temperature, etc.) in excess of absolute maximum ratings. Do not exceed these ratings.

2. Recommended Operating Conditions

($V_{SS} = AV_{SS} = 0.0\text{ V}$)

Parameter	Symbol	Value		Unit	Remarks
		Min	Max		
Power supply voltage	V_{CC} AV_{CC}	4.5	5.5	V	Normal operation
		4.0	5.5	V	Normal operation when D/A converter is not used
		3.5	5.5	V	Normal operation when A/D converter and D/A converter are not used
		3.0	5.5	V	Maintains state in stop operation
Smoothing capacitor	C_S	0.1	1.0	μF	Use a ceramic capacitor or a capacitor with equivalent frequency characteristics. The bypass capacitor to be connected to the V_{CC} pin must have a capacitance value higher than C_S .
Operating temperature	T_A	-40	+85	$^{\circ}\text{C}$	

• C pin connection circuit

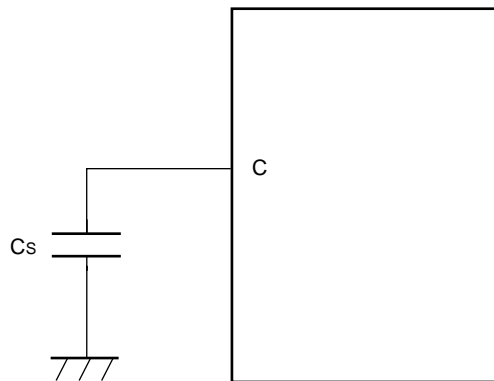

WARNING: The recommended operating conditions are required in order to ensure the normal operation of the semiconductor device. All of the device's electrical characteristics are warranted when the device is operated within these ranges.

Always use semiconductor devices within their recommended operating condition ranges. Operation outside these ranges may adversely affect reliability and could result in device failure.

No warranty is made with respect to uses, operating conditions, or combinations not represented on the data sheet. Users considering application outside the listed conditions are advised to contact their FUJITSU representatives beforehand.

MB90820 Series

3. DC Characteristics

($V_{CC} = 5.0\text{ V} \pm 10\%$, $V_{SS} = AV_{SS} = 0.0\text{ V}$, $T_A = -40\text{ }^\circ\text{C}$ to $+85\text{ }^\circ\text{C}$)

Parameter	Symbol	Pin name	Condition	Value			Unit	Remarks
				Min	Typ	Max		
"H" level output voltage	V_{OH}	All output pins	$V_{CC} = 4.5\text{ V}$, $I_{OH} = -4.0\text{ mA}$	$V_{CC} - 0.5$	—	—	V	
"L" level output voltage	V_{OL1}	All pins except P00 to P07 P82 to P87	$V_{CC} = 4.5\text{ V}$, $I_{OL1} = 4.0\text{ mA}$	—	—	0.4	V	
	V_{OL2}	P00 to P07 P82 to P87	$V_{CC} = 4.5\text{ V}$, $I_{OL2} = 12.0\text{ mA}$	—	—	0.4	V	
"H" level input voltage	V_{IH}	P30 to P37 P60 to P67	$V_{CC} = 4.5\text{ V}$ to 5.5 V	$0.7 V_{CC}$	—	$V_{CC} + 0.3$	V	CMOS input pin
	V_{IHS}	P00 to P07 P10 to P17 P20 to P27 P40 to P47 *1 P50 to P51 P70 to P77 *1 P80 to P87 \overline{RST}		$0.8 V_{CC}$	—	$V_{CC} + 0.3$	V	CMOS hysteresis input pin
	V_{IHM}	MD0 to MD2		$V_{CC} - 0.3$	—	$V_{CC} + 0.3$	V	MD input pin
"L" level input voltage	V_{IL}	P30 to P37 P60 to P67		$V_{SS} - 0.3$	—	$0.3 V_{CC}$	V	CMOS input pin
	V_{ILS}	P00 to P07 P10 to P17 P20 to P27 P40 to P47 *1 P50 to P51 P70 to P77 *1 P80 to P87 \overline{RST}		$V_{SS} - 0.3$	—	$0.2 V_{CC}$	V	CMOS hysteresis input pin
	V_{ILM}	MD0 to MD2		$V_{SS} - 0.3$	—	$V_{SS} + 0.3$	V	MD input pin
Input leakage current	I_{IL}	All input pins	$V_{CC} = 5.5\text{ V}$, $V_{SS} < V_I < V_{CC}$	-5	—	5	μA	
Pull-up resistance	R_{UP}	P00 to P07 P10 to P17 P20 to P27 P30 to P37 \overline{RST}	—	25	50	100	$\text{k}\Omega$	
Pull-down resistance	R_{DOWN}	MD2	—	25	50	100	$\text{k}\Omega$	Not available in MB90F822/MB90F823

(Continued)

MB90820 Series

(Continued)

($V_{CC} = 5.0\text{ V} \pm 10\%$, $V_{SS} = AV_{SS} = 0.0\text{ V}$, $T_A = -40\text{ }^\circ\text{C}$ to $+85\text{ }^\circ\text{C}$)

Parameter	Symbol	Pin name	Condition	Value			Unit	Remarks	
				Min	Typ	Max			
Power supply current*	I _{CC}	V _{CC}	V _{CC} = 5.0 V, Internal frequency: 24 MHz, At normal operation	—	35	50	mA	MB90822	
			—	45	60	mA	MB90F822/F823		
			V _{CC} = 5.0 V, Internal frequency: 24 MHz, At writing in flash memory	—	50	65	mA	MB90822	
			—	60	75	mA	MB90F822/F823		
			V _{CC} = 5.0 V, Internal frequency: 24 MHz, At erasing memory	—	55	70	mA	MB90822	
			—	65	80	mA	MB90F822/F823		
	I _{CCS}		V _{CC} = 5.0 V, Internal frequency: 24 MHz, At sleep mode	—	15	25	mA	MB90822	
			—	mA			MB90F822/F823		
	I _{CTS}		V _{CC}	V _{CC} = 5.0 V, Internal frequency: 2 MHz, At main timer mode	—	0.3	0.8	mA	MB90822
				—	mA			MB90F822/F823	
	I _{CTT}		V _{CC}	V _{CC} = 5.0 V, Internal frequency: 8 MHz, At timer mode, T _A = +25 °C	—	3	7	mA	MB90822
				—	μA			MB90F822/F823	
I _{CHH}	V _{CC}	In stop mode, T _A = +25 °C	—	5	20	mA	MB90822		
			—			μA	MB90F822/F823		
Input capacitance	C _{IN}	Except AV _{CC} , AV _{SS} , AVR, C, V _{CC} and V _{SS}	—	—	5	15	pF		

*1 : UART0, UART1 data input pins P45/SIN0, P72/SIN1 can be selected as CMOS input by user program.

*2 : Current values are tentative. They may be subject to change for enhanced characteristics without previous notice. The power supply current is measured with an external clock.

MB90820 Series

4. AC Characteristics

(1) Clock Timings

($V_{CC} = 5.0\text{ V} \pm 10\%$, $V_{SS} = AV_{SS} = 0.0\text{ V}$, $T_A = -40\text{ }^\circ\text{C}$ to $+85\text{ }^\circ\text{C}$)

Parameter	Symbol	Pin name	Value			Unit	Remarks
			Min	Typ	Max		
Clock frequency	F_C	X0, X1	3	—	16	MHz	Crystal oscillator
			3	—	24	MHz	External clock
Clock cycle time	t_{HCYL}	X0, X1	62.5	—	333	ns	Crystal oscillator
			41.67	—	333	ns	External clock
Input clock pulse width	P_{WH} P_{WL}	X0	10	—	—	ns	Recommend duty ratio of 30% to 70%
Input clock rise/fall time	t_{CR} t_{CF}	X0	—	—	5	ns	External clock operation
Internal operating clock frequency	f_{CP}	—	1.5	—	24	MHz	
Internal operating clock cycle time	t_{CP}	—	41.67	—	666	ns	

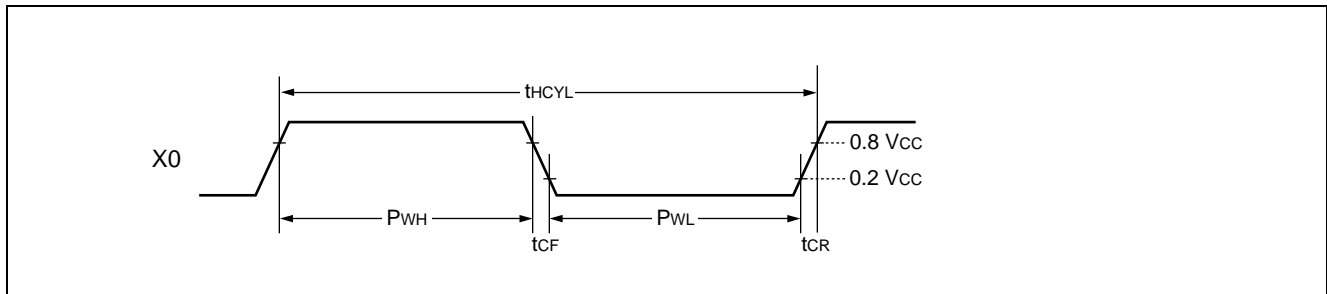

Relationship between internal operating clock frequency and power supply voltage

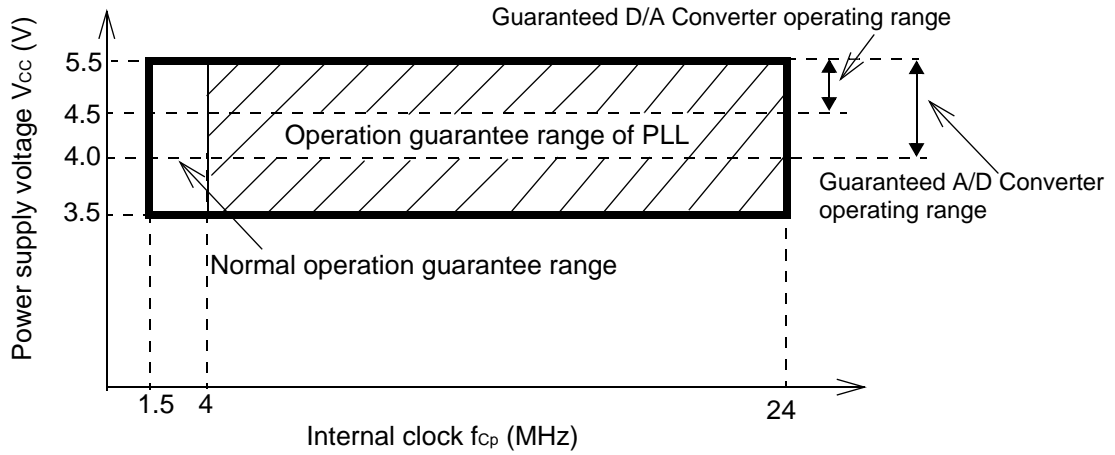

Relationship between oscillating frequency and internal operating clock frequency

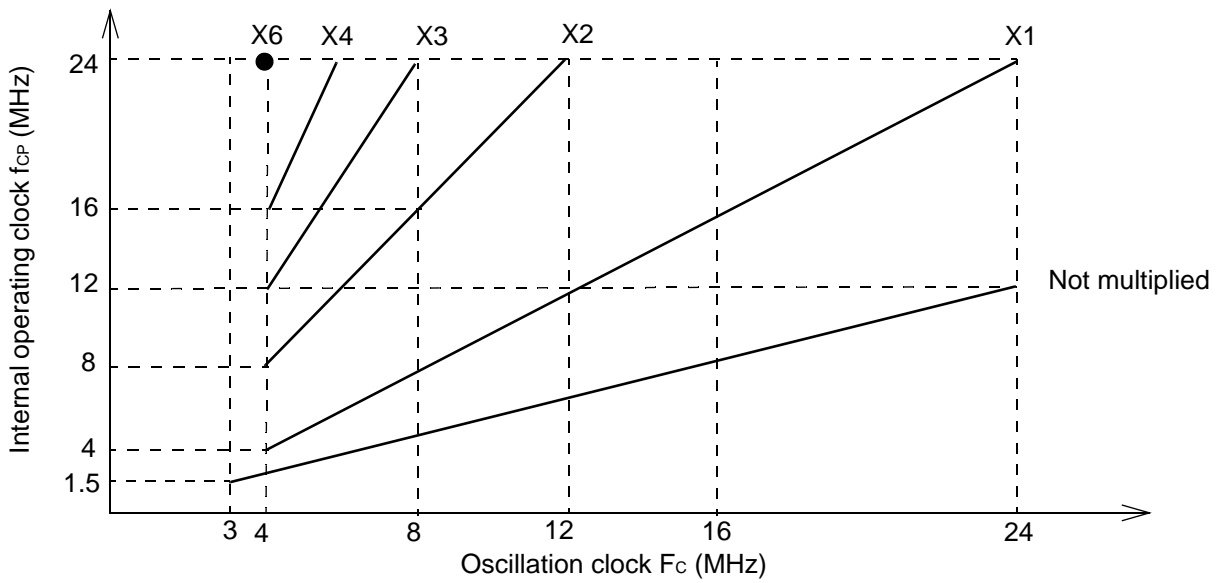

The AC ratings are measured for the following measurement reference voltages

• Input signal waveform

Hysteresis input pin

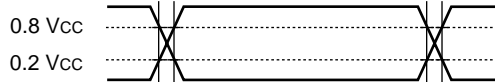

• Output signal waveform

Output pin

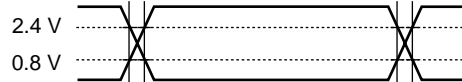

Pins other than hysteresis input/MD input



MB90820 Series

(2) Reset Input Timing

($V_{CC} = 5.0 V \pm 10\%$, $V_{SS} = AV_{SS} = 0.0 V$, $T_A = -40\text{ }^\circ\text{C to } +85\text{ }^\circ\text{C}$)

Parameter	Symbol	Pin name	Value		Unit	Remarks
			Min	Max		
Reset input time	t_{RSTL}	\overline{RST}	500	—	ns	Normal operation
			Oscillation time of oscillator* + 100	—	μs	Stop mode
			100	—	μs	Timebase timer mode

* : Oscillation time of oscillator is the time to reach to 90% of the oscillation amplitude from stand still. In the crystal oscillator, the oscillation time is between several ms to tens of ms. In FAR/ceramic oscillator, the oscillation time is between hundreds of μs to several ms. In the external clock, the oscillation time is 0 ms.

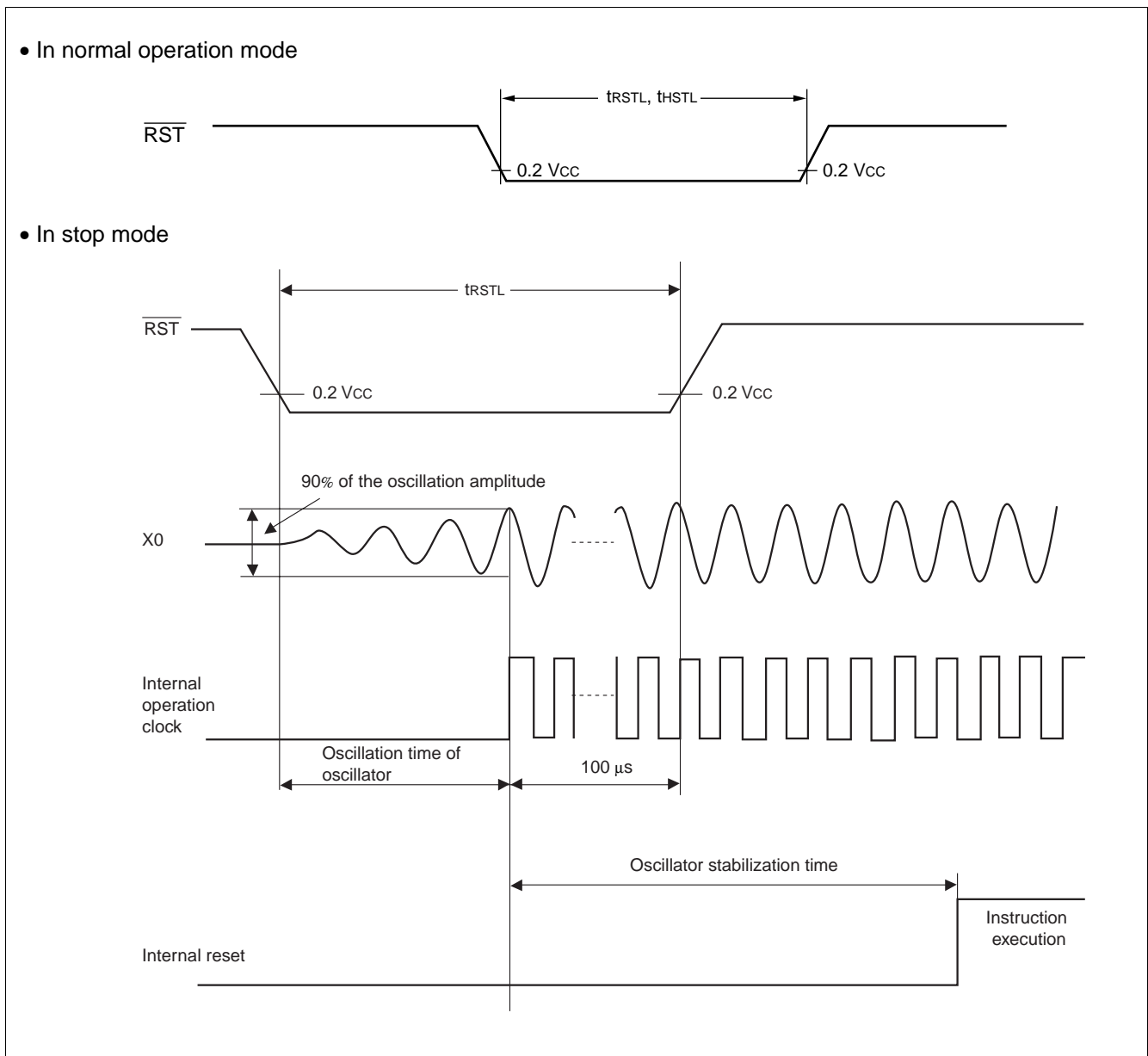

(3) Power-on Reset

($V_{CC} = 5.0\text{ V} \pm 10\%$, $V_{SS} = AV_{SS} = 0.0\text{ V}$, $T_A = -40\text{ }^\circ\text{C}$ to $+85\text{ }^\circ\text{C}$)

Parameter	Symbol	Pin name	Condition	Value		Unit	Remarks
				Min	Max		
Power supply rising time	t_R	V_{CC}	—	0.05	30	ms	
Power supply cut-off time	t_{OFF}	V_{CC}		1	—	ms	Due to repeated operations

- Notes :
- V_{CC} must be kept lower than 0.2 V before power-on.
 - The above values are used for causing a power-on reset.
Some registers in the device are initialized only upon a power-on reset. To initialize these registers, turn the power supply using the above values.

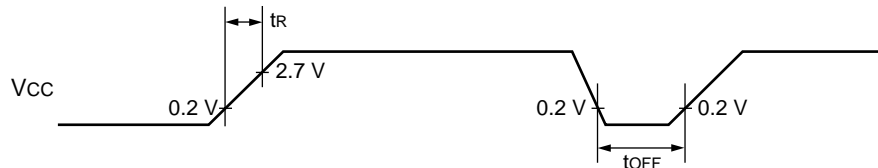

Sudden changes in the power supply voltage may cause a power-on reset. To change the power supply voltage while the device is in operation, it is recommended to raise the voltage smoothly to suppress fluctuations as shown below. In this case, change the supply voltage with the PLL clock not used. If the voltage drop is 1 V/s, however, you can use the PLL clock.

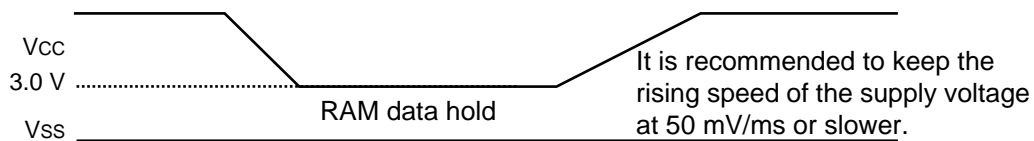

MB90820 Series

(4) UART0 to UART1

($V_{CC} = 5.0 V \pm 10\%$, $V_{SS} = AV_{SS} = 0.0 V$, $T_A = -40\text{ }^{\circ}\text{C}$ to $+85\text{ }^{\circ}\text{C}$)

Parameter	Symbol	Pin name	Condition	Value		Unit	Remarks
				Min	Max		
Serial clock cycle time	t_{SCYC}	SCK0 to SCK1	$C_L = 80\text{ pF} + 1\text{ TTL}$ for an output pin of internal shift clock mode	8 t_{CP}	—	ns	
SCK ↓ → SOT delay time	t_{SLOV}	SCK0 to SCK1 SOT0 to SOT1		-80	80	ns	
Valid SIN → SCK ↑	t_{VSH}	SCK0 to SCK1 SIN0 to SIN1		100	—	ns	
SCK ↑ → valid SIN hold time	t_{SHIX}	SCK0 to SCK1 SIN0 to SIN1		60	—	ns	
Serial clock "H" pulse width	t_{SHSL}	SCK0 to SCK1	$C_L = 80\text{ pF} + 1\text{ TTL}$ for an output pin of external shift clock mode	4 t_{CP}	—	ns	
Serial clock "L" pulse width	t_{LSLH}	SCK0 to SCK1		4 t_{CP}	—	ns	
SCK ↓ → SOT delay time	t_{SLOV}	SCK0 to SCK1 SOT0 to SOT1		—	150	ns	
Valid SIN → SCK ↑	t_{VSH}	SCK0 to SCK1 SIN0 to SIN1		60	—	ns	
SCK ↑ → valid SIN hold time	t_{SHIX}	SCK0 to SCK1 SIN0 to SIN1		60	—	ns	

- Notes :
- These are AC ratings in the CLK synchronous mode.
 - C_L is the load capacitance value connected to pins while testing.
 - t_{CP} is machine cycle time (unit : ns).

- Internal shift clock mode

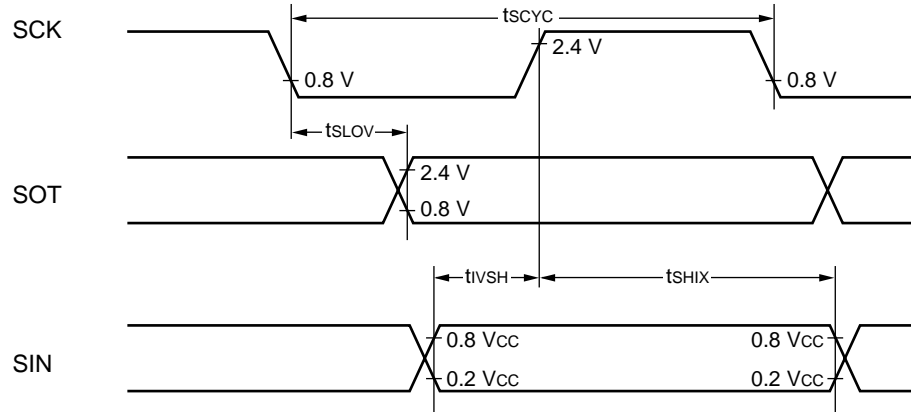

- External shift clock mode

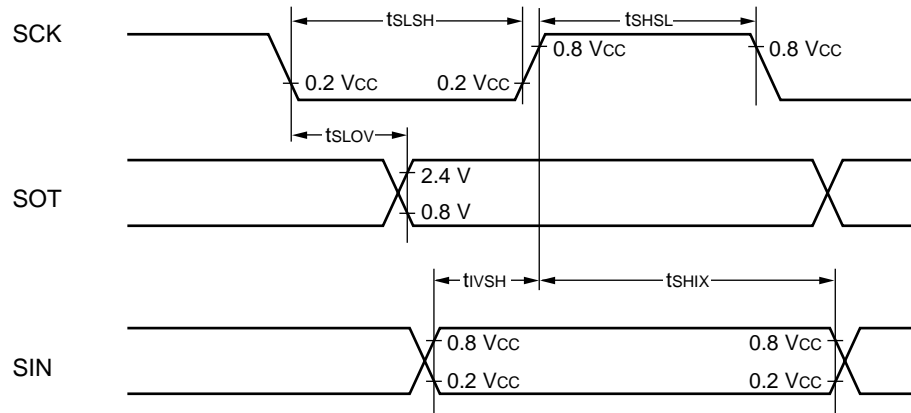

MB90820 Series

(5) Resources Input Timing

($V_{CC} = 5.0 V \pm 10\%$, $V_{SS} = AV_{SS} = 0.0 V$, $T_A = -40\text{ }^\circ\text{C}$ to $+85\text{ }^\circ\text{C}$)

Parameter	Symbol	Pin name	Condition	Value		Unit	Remarks
				Min	Max		
Input pulse width	t_{TIWH} t_{TIWL}	IN0 to IN3, TIN0 to TIN1, PW10 to PW11, DTTI	—	4 t_{CP}	—	ns	

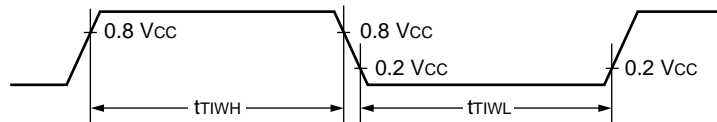

(6) Trigger Input Timing

($V_{CC} = 5.0 V \pm 10\%$, $V_{SS} = AV_{SS} = 0.0 V$, $T_A = -40\text{ }^\circ\text{C}$ to $+85\text{ }^\circ\text{C}$)

Parameter	Symbol	Pin name	Condition	Value		Unit	Remarks
				Min	Max		
Input pulse width	t_{TRGH} t_{TRGL}	INT0 to INT7	—	5 t_{CP}	—	ns	

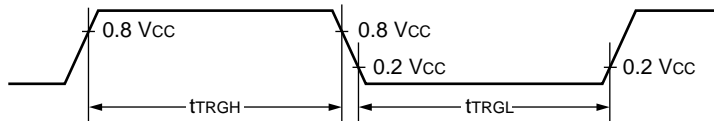

5. A/D Converter Electrical Characteristics

($3.0\text{ V} \leq \text{AVR} - \text{AV}_{\text{SS}}$, $V_{\text{CC}} = \text{AV}_{\text{CC}} = 5.0\text{ V} \pm 10\%$, $V_{\text{SS}} = \text{AV}_{\text{SS}} = 0.0\text{ V}$, $T_{\text{A}} = -40\text{ }^{\circ}\text{C}$ to $+85\text{ }^{\circ}\text{C}$)

Parameter	Symbol	Pin name	Value			Unit	Remarks
			Min	Typ	Max		
Resolution	—	—	—	10	—	bit	
Total error	—	—	—	—	± 3.0	LSB	
Non-linearity error	—	—	—	—	± 2.5	LSB	
Differential linearity error	—	—	—	—	± 1.9	LSB	
Zero transition voltage	V_{OT}	AN0 to AN15	$\text{AV}_{\text{SS}} - 1.5\text{ LSB}$	$\text{AV}_{\text{SS}} + 0.5\text{ LSB}$	$\text{AV}_{\text{SS}} + 2.5\text{ LSB}$	mV	
Full-scale transition voltage	V_{FST}	AN0 to AN15	$\text{AVR} - 3.5\text{ LSB}$	$\text{AVR} - 1.5\text{ LSB}$	$\text{AVR} + 0.5\text{ LSB}$	mV	
Compare time	—	—	1.0	—	—	μs	$4.5\text{ V} \leq \text{AV}_{\text{CC}} \leq 5.5\text{ V}$
			2.0	—	—	μs	$4.0\text{ V} \leq \text{AV}_{\text{CC}} < 4.5\text{ V}$
Sampling time	—	—	0.5	—	—	μs	$4.5\text{ V} \leq \text{AV}_{\text{CC}} \leq 5.5\text{ V}$
			1.2	—	—	μs	$4.0\text{ V} \leq \text{AV}_{\text{CC}} < 4.5\text{ V}$
Analog port input current	I_{AIN}	AN0 to AN15	- 0.3	—	+ 0.3	μA	
Analog input voltage	V_{AIN}	AN0 to AN15	AV_{SS}	—	AVR	V	
Reference voltage	—	AVR	$\text{AV}_{\text{SS}} + 2.7$	—	AV_{CC}	V	
Power supply current	I_{A}	AV_{CC}	—	2.4	4.7	mA	
	I_{AH}		—	—	5	μA	*
Reference voltage supply current	I_{R}	AVR	—	600	900	μA	
	I_{RH}		—	—	5	μA	*
Offset between channels	—	AN0 to AN15	—	—	4	LSB	

* : The current when the A/D converter is not operating or the CPU is in stop mode (for $V_{\text{CC}} = \text{AV}_{\text{CC}} = \text{AVR} = 5.0\text{ V}$)

Note : The error increases proportionally as $|\text{AVR} - \text{AV}_{\text{SS}}|$ decreases.

6. A/D Converter Glossary

- Resolution : Analog variation that is recognized by an A/D converter.
- Non linearity error : Deviation between a line across zero-transition line (“00 0000 0000”↔“00 0000 0001”) and full-scale transition line (“11 1111 1110”↔“11 1111 1111”) and actual conversion characteristics.
- Differential linearity error : Deviation of input voltage, which is required for changing output code by 1 LSB, from an ideal value
- Total error : Difference between an actual value and an ideal value. A total error includes zero transition error, full-scale transition error, and linear error.

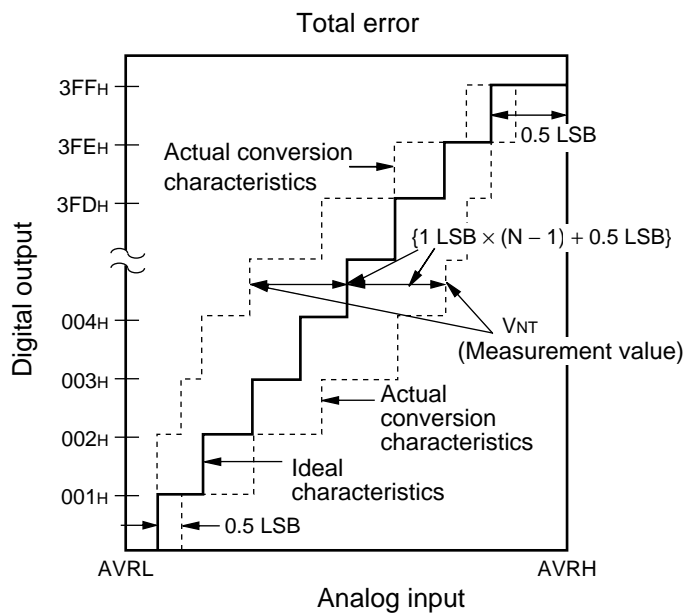

$$\text{Total error for digital output } N = \frac{V_{NT} - \{1 \text{ LSB} \times (N - 1) + 0.5 \text{ LSB}\}}{1 \text{ LSB}} \quad [\text{LSB}]$$

$$1 \text{ LSB} = (\text{Ideal value}) \frac{AVR - AV_{SS}}{1024} \quad [\text{V}]$$

$$V_{OT}(\text{Ideal value}) = AV_{SS} + 0.5 \text{ LSB} \quad [\text{V}]$$

$$V_{FST}(\text{Ideal value}) = AVR - 1.5 \text{ LSB} \quad [\text{V}]$$

V_{NT} : Voltage at which of digital output transitions from (N - 1) to N.

(Continued)

(Continued)

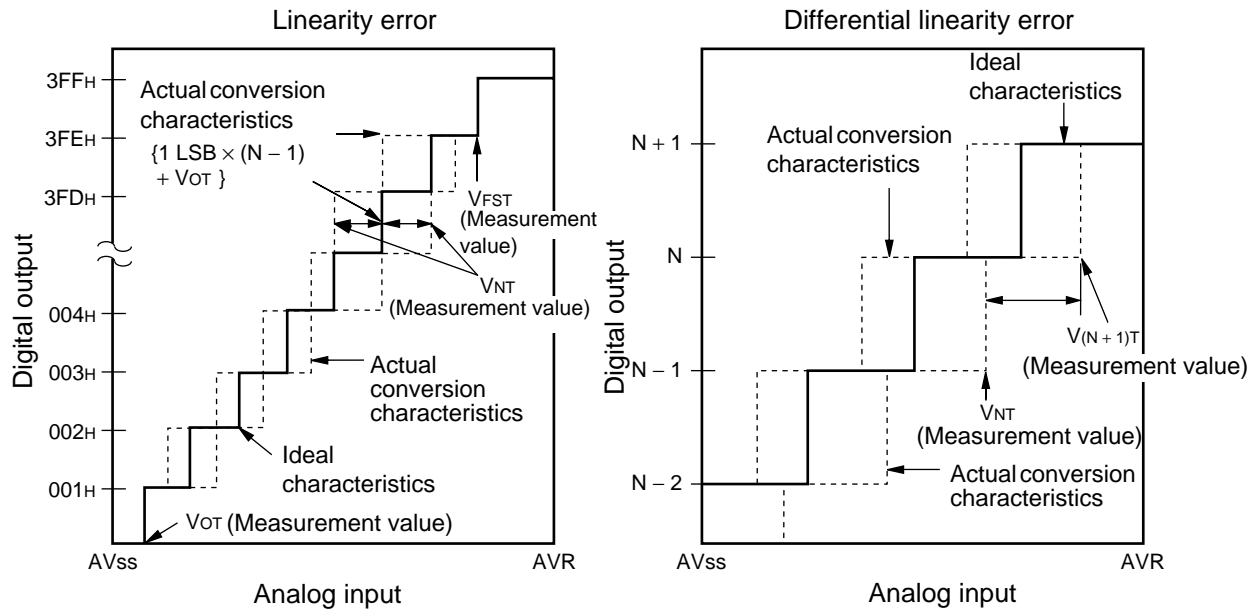

$$\text{Linearity error of digital output } N = \frac{V_{NT} - \{1 \text{ LSB} \times (N - 1) + V_{OT}\}}{1 \text{ LSB}} \quad [\text{LSB}]$$

$$\text{Differential linearity error of digital output } N = \frac{V_{(N+1)T} - V_{NT}}{1 \text{ LSB}} - 1 \quad [\text{LSB}]$$

$$1 \text{ LSB} = \frac{V_{FST} - V_{OT}}{1022} \quad [\text{V}]$$

V_{OT} : Voltage at which of digital output transmissions from "000H" to "001H".

V_{FST} : Voltage at which of digital output transmissions from "3FEH" to "3FFH".

MB90820 Series

7. Notes on Using A/D Converter

• About the external impedance of the analog input and its sampling time

- A/D converter with sample and hold circuit. If the external impedance is too high to keep sufficient sampling time, the analog voltage charged to the internal sample and hold capacitor is insufficient, adversely affecting A/D conversion precision.

- Analog input circuit model

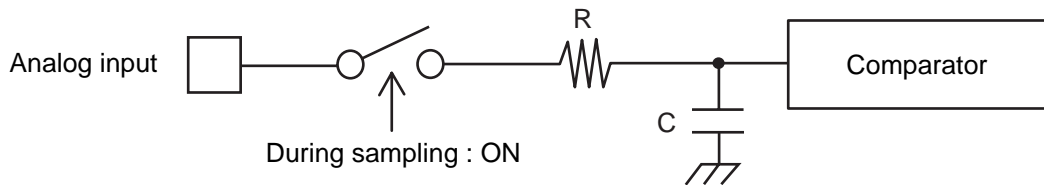

	R	C
MB90822	2.0 kΩ (Max)	14.4 pF (Max)
MB90F822	2.0 kΩ (Max)	16.0 pF (Max)

Note : The values are reference values.

- To satisfy the A/D conversion precision standard, consider the relationship between the external impedance and minimum sampling time and either adjust the resistor value and operating frequency or decrease the external impedance so that the sampling time is longer than the minimum value.

- The relationship between the external impedance and minimum sampling time

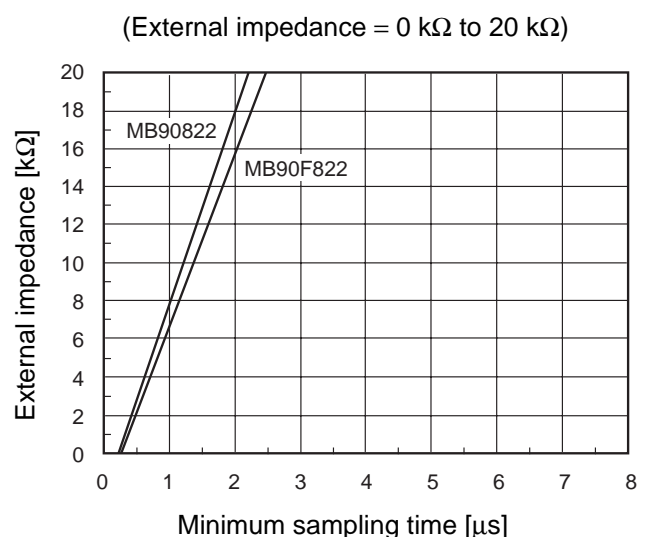
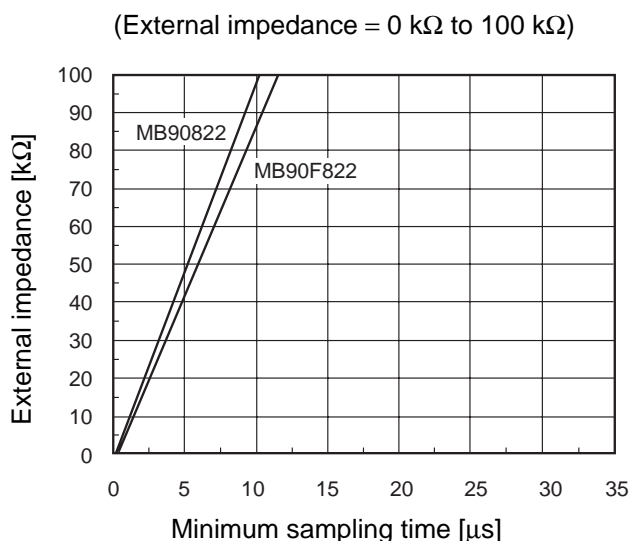

- If the sampling time cannot be sufficient, connect a capacitor of about 0.1 μF to the analog input pin.
- About the error
The accuracy gets worse as $|AVR - AV_{SS}|$ becomes smaller.

8. Electrical Characteristics of D/A convertor

($V_{CC} = AV_{CC} = 4.5 \text{ V to } 5.5 \text{ V}$, $V_{SS} = AV_{SS} = 0.0 \text{ V}$, $T_A = -40 \text{ }^\circ\text{C to } +85 \text{ }^\circ\text{C}$)

Parameter	Symbol	Pin name	Condition	Value			Unit	Remarks
				Min	Typ	Max		
Resolution	—	—	—	—	8	—	bit	
Differential linearity error	—	—		—	—	± 0.5	LSB	
Conversion time	—	—		—	0.45	—	μs	*
Analog output impedance	—	—		—	2.9	3.8	$\text{k}\Omega$	
Power supply current	I_{DVR}	AV_{CC}		—	160	920	μA	
	I_{DVRS}			—	0.1	—	μA	D/A stops

* : With load capacitance 20 pF.

MB90820 Series

9. Flash Memory Program/Erase Characteristics

Parameter	Condition	Value			Unit	Remarks
		Min	Typ	Max		
Sector erase time	T _A = +25 °C V _{CC} = 5.0 V	—	1	15	s	Excludes programming prior to erasure
Chip erase time		—	9	—	s	Excludes programming prior to erasure
Word (16 bit width) programing time		—	16	3,600	μs	Except for the overhead time of the system
Program/Erase cycle	—	10,000	—	—	cycle	
Flash data retention time	Average T _A = +85 °C	20	—	—	Year	*

* : This value comes from the technology qualification (using Arrhenius equation to translate high temperature measurements into normalized value at + 85 °C) .

■ ORDERING INFORMATION

Part number	Package	Remarks
MB90F823PFV MB90F822PFV MB90822PFV	80-pin Plastic LQFP (FPT-80P-M05)	
MB90F823PFM MB90F822PFM MB90822PFM	80-pin Plastic LQFP (FPT-80P-M11)	
MB90F823PF MB90F822PF MB90822PF	80-pin Plastic QFP (FPT-80P-M06)	

■ PACKAGE DIMENSIONS

80-pin plastic QFP
(FPT-80P-M06)

Note 1) * : These dimensions do not include resin protrusion.
 Note 2) Pins width and pins thickness include plating thickness.
 Note 3) Pins width do not include tie bar cutting remainder.

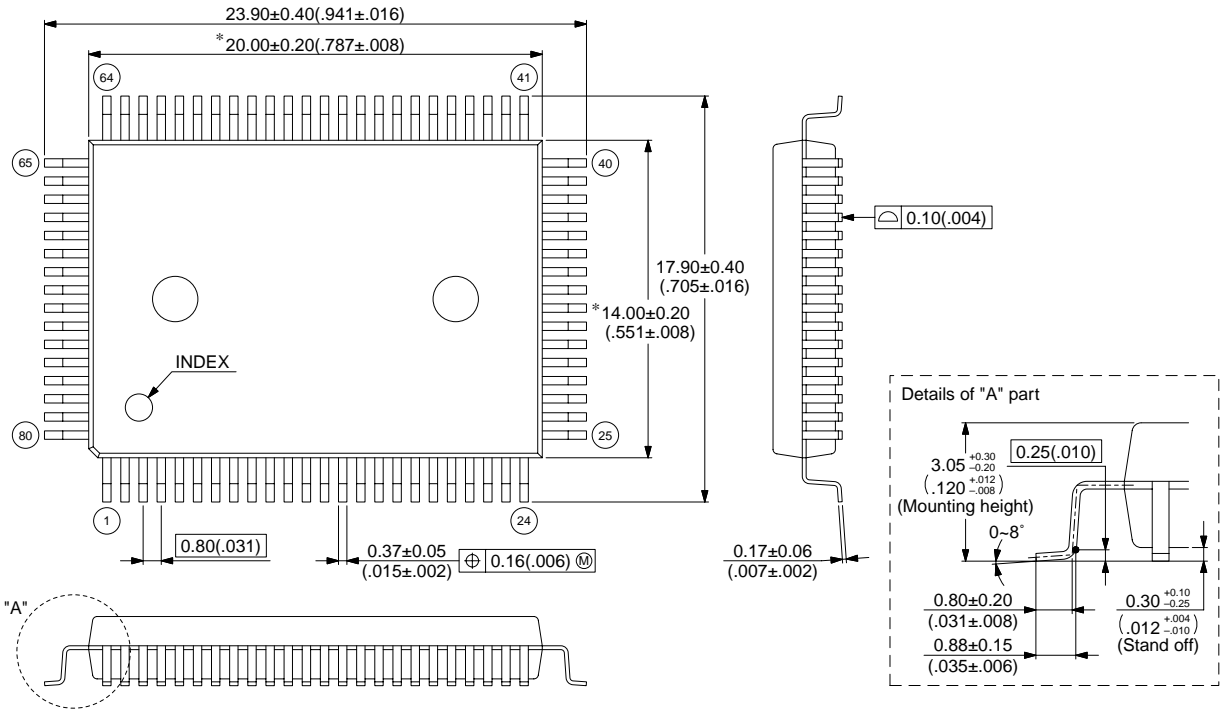

© 2002 FUJITSU LIMITED F80010S-c-6-5

Dimensions in mm (inches)

Note : The values in parentheses are reference values.

(Continued)

MB90820 Series

80-pin plastic LQFP
(FPT-80P-M11)

Note 1) * : These dimensions do not include resin protrusion.
 Note 2) Pins width and pins thickness include plating thickness.
 Note 3) Pins width do not include tie bar cutting remainder.

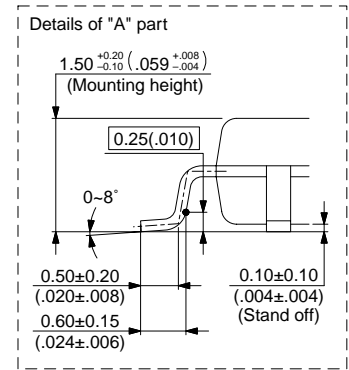
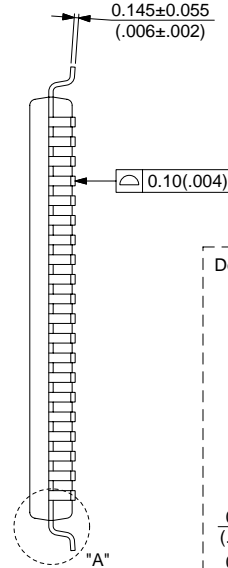
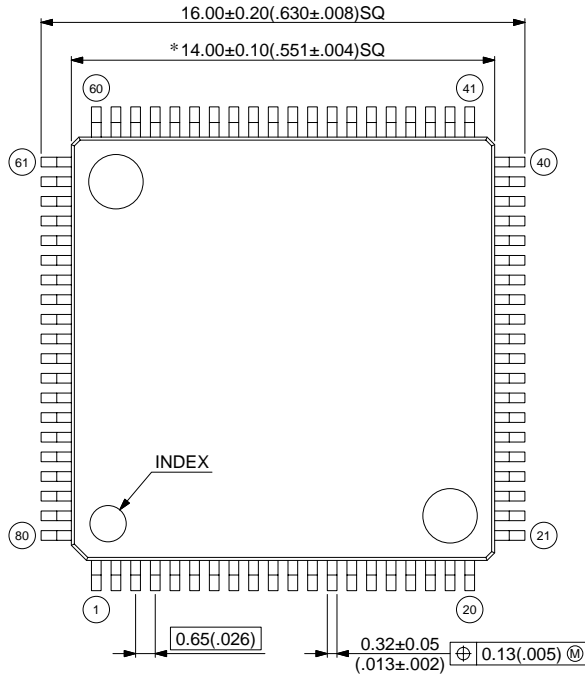

© 2003 FUJITSU LIMITED F80016S-c-3-6

Dimensions in mm (inches)

Note : The values in parentheses are reference values.

(Continued)

MB90820 Series

(Continued)

80-pin plastic LQFP
(FPT-80P-M05)

Note 1) * : These dimensions do not include resin protrusion.
 Note 2) Pins width and pins thickness include plating thickness.
 Note 3) Pins width do not include tie bar cutting remainder.

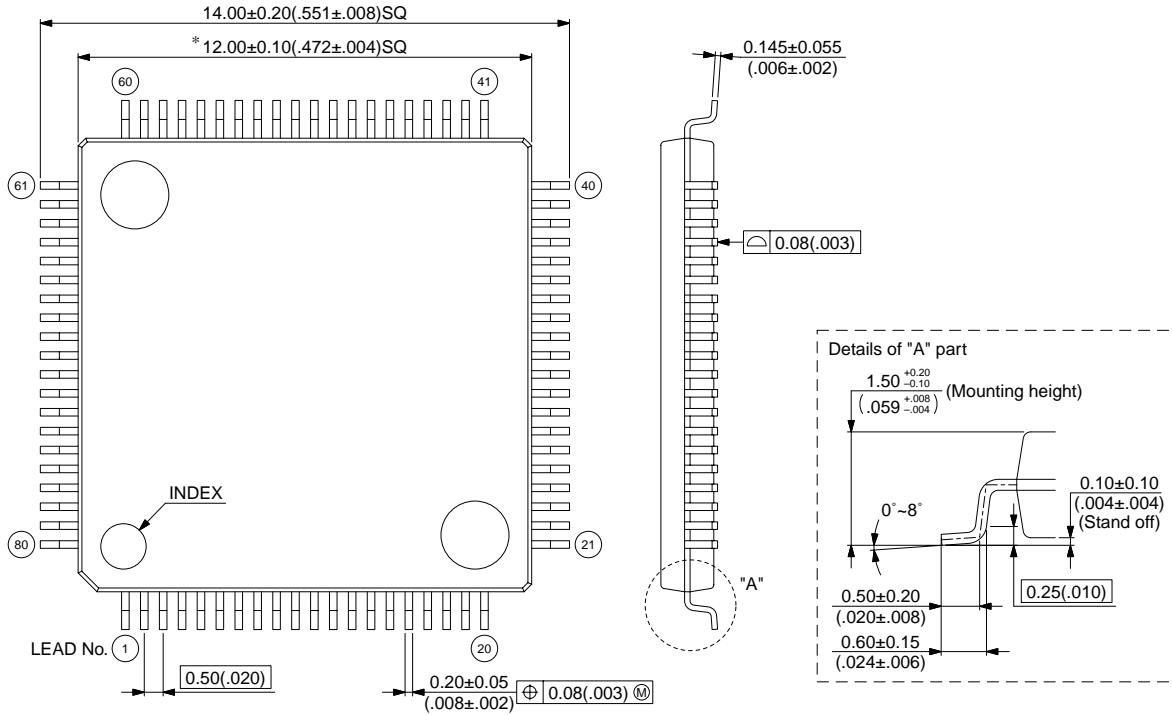

© 2003 FUJITSU LIMITED F80008S-c-4-8

Dimensions in mm (inches)

Note : The values in parentheses are reference values.

FUJITSU LIMITED

All Rights Reserved.

The contents of this document are subject to change without notice. Customers are advised to consult with FUJITSU sales representatives before ordering.

The information, such as descriptions of function and application circuit examples, in this document are presented solely for the purpose of reference to show examples of operations and uses of Fujitsu semiconductor device; Fujitsu does not warrant proper operation of the device with respect to use based on such information. When you develop equipment incorporating the device based on such information, you must assume any responsibility arising out of such use of the information. Fujitsu assumes no liability for any damages whatsoever arising out of the use of the information.

Any information in this document, including descriptions of function and schematic diagrams, shall not be construed as license of the use or exercise of any intellectual property right, such as patent right or copyright, or any other right of Fujitsu or any third party or does Fujitsu warrant non-infringement of any third-party's intellectual property right or other right by using such information. Fujitsu assumes no liability for any infringement of the intellectual property rights or other rights of third parties which would result from the use of information contained herein.

The products described in this document are designed, developed and manufactured as contemplated for general use, including without limitation, ordinary industrial use, general office use, personal use, and household use, but are not designed, developed and manufactured as contemplated (1) for use accompanying fatal risks or dangers that, unless extremely high safety is secured, could have a serious effect to the public, and could lead directly to death, personal injury, severe physical damage or other loss (i.e., nuclear reaction control in nuclear facility, aircraft flight control, air traffic control, mass transport control, medical life support system, missile launch control in weapon system), or (2) for use requiring extremely high reliability (i.e., submersible repeater and artificial satellite).

Please note that Fujitsu will not be liable against you and/or any third party for any claims or damages arising in connection with above-mentioned uses of the products.

Any semiconductor devices have an inherent chance of failure. You must protect against injury, damage or loss from such failures by incorporating safety design measures into your facility and equipment such as redundancy, fire protection, and prevention of over-current levels and other abnormal operating conditions.

If any products described in this document represent goods or technologies subject to certain restrictions on export under the Foreign Exchange and Foreign Trade Law of Japan, the prior authorization by Japanese government will be required for export of those products from Japan.