

Single-Ended Bus Transceiver

FEATURES

- Operating Power Supply Range $6\text{ V} \leq V_{\text{BAT}} \leq 36\text{ V}$
- Reverse Battery Protection Down to $V_{\text{BAT}} \geq -24\text{ V}$
- Standby Mode With Very Low Current Consumption
 $I_{\text{BAT(SB)}} = 1\ \mu\text{A}$ @ $V_{\text{DD}} = 0.5\text{ V}$
- Low Quiescent Current in OFF Condition
 $I_{\text{BAT}} = 120\ \mu\text{A}$ and $I_{\text{DD}} \leq 10\ \mu\text{A}$
- ISO 9141 Compatible
- Overtemperature Shutdown Function For K Output
- Defined K Output OFF for Open GND
- Defined Receive Output Status for Open K Input
- Defined K Output OFF for TX Input Open
- Open Drain Fault Output
- 2-kV ESD
- Typical Transmit Speeds of 200 kBaud

DESCRIPTION

The Si9241AEY is a monolithic bus transceiver designed to provide bidirectional serial communication in automotive diagnostic applications.

The device incorporates protection against overvoltages and short circuits to V_{BAT} . The transceiver pin is protected and can be driven beyond the V_{BAT} voltage.

The Si9241AEY is built on the Vishay Siliconix BiC/DMOS process. An epitaxial layer prevents latchup.

The RX output is capable of driving CMOS or $1 \times$ LSTTL load.

The Si9241AEY is available in a space efficient 8-pin SO package. It operates reliably over the automotive temperature range (-40 to 125°C). The Si9241AEY is available in both standard and lead (Pb)-free packages.

PIN CONFIGURATION AND FUNCTIONAL BLOCK DIAGRAM

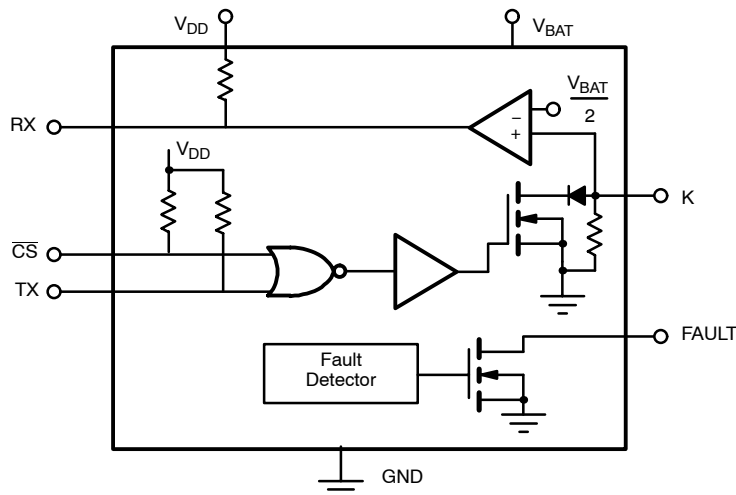



OUTPUT TABLE AND STATE DIAGRAMS

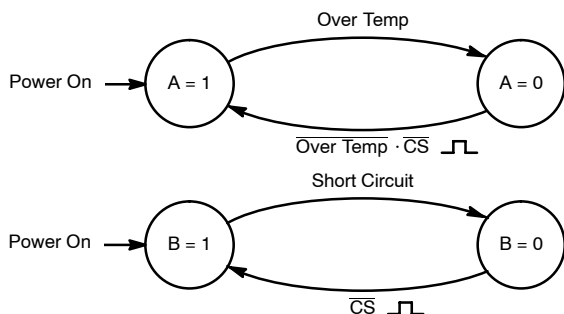

Note: Over Temp is an internal condition, not meant to be a logic signal.

INPUTS		STATE VARIABLE		OUTPUT TABLE			Comments
CS	TX	A	B	RX	K	FAULT	
0	0	1	1	0	0	1	Over Temp Short Circuit
0	1	1	1	1	1	1	
X	X	0	1	K	HiZ	0	
0	X	1	0	K	HiZ	0	
1	X	1	1	0	0	1	Receive Mode
1	X	1	1	1	1	1	

X = "1" or "0"
 HiZ = High Impedance State

ABSOLUTE MAXIMUM RATINGS

Voltage Referenced to Ground
 Voltage On V_{BAT} -24 V to 45 V
 Voltage K -16 V to (V_{BAT} + 1 V)
 Voltage Difference V_(VBAT, K) 55 V
 Voltage or Max. Current On Any Pin
 (Except V_{BAT}, K) -0.3 V to (V_{DD} + 0.3 V) or 10 mA

Voltage on V_{DD} 7 V
 K Pin Only, Short Circuit Duration (to V_{BAT} or GND) Continuous
 Operating Temperature (T_A) -40 to 125°C
 Junction and Storage Temperature -55 to 150°C
 Thermal Resistance Θ_{JA} 125°C/W

Stresses beyond those listed under "Absolute Maximum Ratings" may cause permanent damage to the device. These are stress ratings only, and functional operation of the device at these or any other conditions beyond those indicated in the operational sections of the specifications is not implied. Exposure to absolute maximum rating conditions for extended periods may affect device reliability.

RECOMMENDED OPERATING RANGE

Voltage Referenced to Ground
 V_{DD} 4.5 V to 5.5 V
 V_{BAT} 6 V to 36 V

K 6 V to 36 V
 Digital Inputs 0 to V_{DD}



SPECIFICATIONS								
Parameter	Symbol	Test Conditions Unless Specified		Temp ^a	Limits -40 to 125°C			Unit
		$V_{DD} = 4.5 \text{ to } 5.5 \text{ V}$ $V_{BAT} = 6 \text{ to } 36 \text{ V}$			Min ^b	Typ ^c	Max ^b	
Transmitter and Logic Levels								
\overline{CS} , TX Input Low Voltage	V_{ILT}			Full			1.5	V
\overline{CS} , TX Input High Voltage	V_{IHT}			Full	3.5			
TX Input Capacitance ^d	C_{INT}			Full			10	pF
\overline{CS} , TX Input Pull-up Resistance	R_{TX}, R_{CS}	$V_{DD} = 5.5 \text{ V}$, TX or $\overline{CS} = 1.5 \text{ V}$, 3.5 V		Full	10	20	40	kΩ
K Transmit								
K Output Low Voltage	V_{OLK}	$R_L = 510 \Omega \pm 5\%$, $V_{BAT} = 6 \text{ to } 18 \text{ V}$		Full			$0.2 V_{BAT}$	V
		$R_L = 1 \text{ k}\Omega \pm 5\%$, $V_{BAT} = 16 \text{ to } 36 \text{ V}$		Full			$0.2 V_{BAT}$	
		$R_L = 510 \Omega \pm 5\%$, $V_{BAT} = 4.5 \text{ V}$		Full			1.2	
K Output High Voltage	V_{OHK}	$R_L = 510 \Omega \pm 5\%$, $V_{BAT} = 4.5 \text{ to } 18 \text{ V}$		Full	$0.95 V_{BAT}$			
		$R_L = 1 \text{ k}\Omega \pm 5\%$, $V_{BAT} = 16 \text{ to } 36 \text{ V}$		Full	$0.95 V_{BAT}$			
K Rise, Fall Times	t_r, t_f	See Test Circuit		Full			9.6	μs
K Output Sink Resistance	R_{SI}	$\overline{CS} = 0 \text{ V}$, TX = 0 V		Full			110	Ω
K Output Capacitance ^d	C_O	$\overline{CS} = 0 \text{ V}$, TX = 0 V		Full			20	pF
Receiver								
K Input Low Voltage	V_{ILK}			Full			$0.35 V_{BAT}$	V
K Input High Voltage	V_{IHK}			Full	$0.65 V_{BAT}$			
K Input Hysteresis ^{c, d}	V_{HYS}			Full		$0.05 V_{BAT}$		
K Input Currents	I_{IHK}	$\overline{CS} = 4 \text{ V}$	$V_{IHK} = V_{BAT}$	Full			20	μA
RX Output Low Voltage	V_{OLR}		$V_{ILK} = 0.35 V_{BAT}$ $I_{OLR} = 1 \text{ mA}$	Full				0.4
RX Pull-up Resistance	R_{RX}			Full	5		20	kΩ
RX Turn On Delay	$t_{d(on)}$	$R_L = 510 \Omega \pm 5\%$, $V_{BAT} = 6 \text{ to } 18 \text{ V}$ $C_L = 10 \text{ nF}$, See Test Circuit		Full		3	10	μs
		$R_L = 1 \text{ k}\Omega \pm 5\%$, $V_{BAT} = 16 \text{ to } 36 \text{ V}$ $C_L = 4.7 \text{ nF}$, See Test Circuit		Full		3	10	
RX Turn Off Delay	$t_{d(off)}$	$R_L = 510 \Omega \pm 5\%$, $V_{BAT} = 6 \text{ to } 18 \text{ V}$ $C_L = 10 \text{ nF}$, See Test Circuit		Full		3	10	
		$R_L = 1 \text{ k}\Omega \pm 5\%$, $V_{BAT} = 16 \text{ to } 36 \text{ V}$ $C_L = 4.7 \text{ nF}$, See Test Circuit		Full		3	10	
Supplies								
Bat Supply Current On	$I_{BAT(on)}$	$\overline{CS} = TX = 0 \text{ V}$, $V_{BAT} \leq 16 \text{ V}$		Full		1.2	3	mA
Bat Supply Current Off	$I_{BAT(off)}$	$\overline{CS} = \text{High}$, $V_{BAT} \leq 12 \text{ V}$, TX = High ^f		Full		120	220	μA
Bat Supply Current Standby	$I_{BAT(SB)}$	$V_{DD} \leq 0.5 \text{ V}$, $V_{BAT} \leq 12 \text{ V}$		Full		<1	10	
Logic Supply Current On	$I_{DD(on)}$	$V_{DD} \leq 5.5 \text{ V}$, TX = 0 V		Full		1.4	2.3	mA
Logic Supply Current Off	$I_{DD(off)}$	$\overline{CS} = \text{High}$, $V_{BAT} \leq 12 \text{ V}$, TX = High ^f		Full			10	μA
Miscellaneous								
TX Transmit Baud Rate	BR_T	$R_L = 510 \Omega$, $C_L = 10 \text{ nF}$		Full	10.4			kBaud
RX Receive Baud Rate ^c	BR_R	$6 \text{ V} < V_{BAT} < 16 \text{ V}$, $C_{RX} = 20 \text{ pF}$		Full		200		
Transmission Frequency	$f_{K,RXK}$	$6 \text{ V} < V_{BAT} < 16 \text{ V}$, $R_K = 510 \Omega$, $C_K \leq 1.3 \text{ nF}$		Full	50	200		kHz
Fault Output Low Voltage	V_{OLF}	$\overline{CS} = TX = 0 \text{ V}$, K = V_{BAT} , $I_{OLF} = 1 \text{ mA}$		Full			0.4	V
\overline{CS} Minimum Pulse Width ^{d, e}	t_{cs}			Full	1			μs
Over Temperature Shutdown ^d	T_{SHUT}	Temperature Rising			160	180		°C
Temperature Shutdown Hysteresis ^c	T_{HYST}					30		

Notes

- a. Room = 25°C, Cold and Hot = as determined by the operating temperature suffix.
- b. The algebraic convention whereby the most negative value is a minimum and the most positive a maximum, is used in this data sheet.
- c. Typical values are for DESIGN AID ONLY, not guaranteed nor subject to production testing.
- d. Guaranteed by design, not subject to production test.
- e. Minimum pulse width to reset a fault condition.
- f. High refers to Logic High and Low refers to Logic Low.

PIN CONFIGURATION

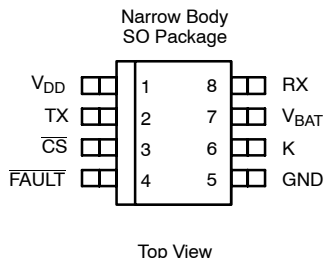

ORDERING INFORMATION	
Part Number	Temperature Range
Si9241AEY-T1	-40 to 125°C
Si9241AEY-T1—E3 (Lead (Pb)-Free)	

PIN DESCRIPTION		
Pin Number	Symbol	Description
1	V _{DD}	Positive Power Supply
2	TX	Transmit, Input
3	\overline{CS}	Chip Select, Input
4	\overline{FAULT}	Fault, Open Drain Output
5	GND	Ground Connection
6	K	Transmit/Receive, Bidirectional
7	V _{BAT}	Battery Power Supply
8	RX	Receiver, Output

FUNCTIONAL DESCRIPTION

The Si9241AEY can be either in transmit or receive mode and it contains over temperature, and short circuit V_{BAT} fault detection circuits.

The voltage on K is internally compared to V_{BAT/2}. If the voltage on the K pin is less than V_{BAT/2} then RX output will be “low.” If the voltage on the K pin is greater than V_{BAT/2} then RX output will be “high.”

In order to be in transmit mode, \overline{CS} must be set “low.” When \overline{CS} and TX are set “low” the internal MOSFET will turn on, causing the K pin to be “low.” In the transmit mode, the processor monitors RX and TX. When the two mirror each other there is no fault. In the event of over temperature, or short

circuit to V_{BAT}, the Si9241AEY will turn off the K output to protect the IC and the external open drain \overline{FAULT} pin will be asserted. The K pin will stay in high impedance and RX will follow the K pin. The fault will be reset when \overline{CS} is toggled high. RX, \overline{CS} and TX pins have an internal pull up resistor to V_{DD} while the K pin has internal pull down resistors. When any one of the TX, V_{BAT} or GND pins is open the K output is off.

When \overline{CS} is set “high” the Si9241AEY is in receive mode and the internal MOSFET for the K pin is turned off. The RX output will follow the K pin. If \overline{CS} is “low” while the IC is receiving data, an incorrect fault signal will occur.

To inhibit the short detect, tie \overline{CS} and TX together.

TEST CIRCUIT AND TIMING DIAGRAMS (TRANSMIT ONLY)

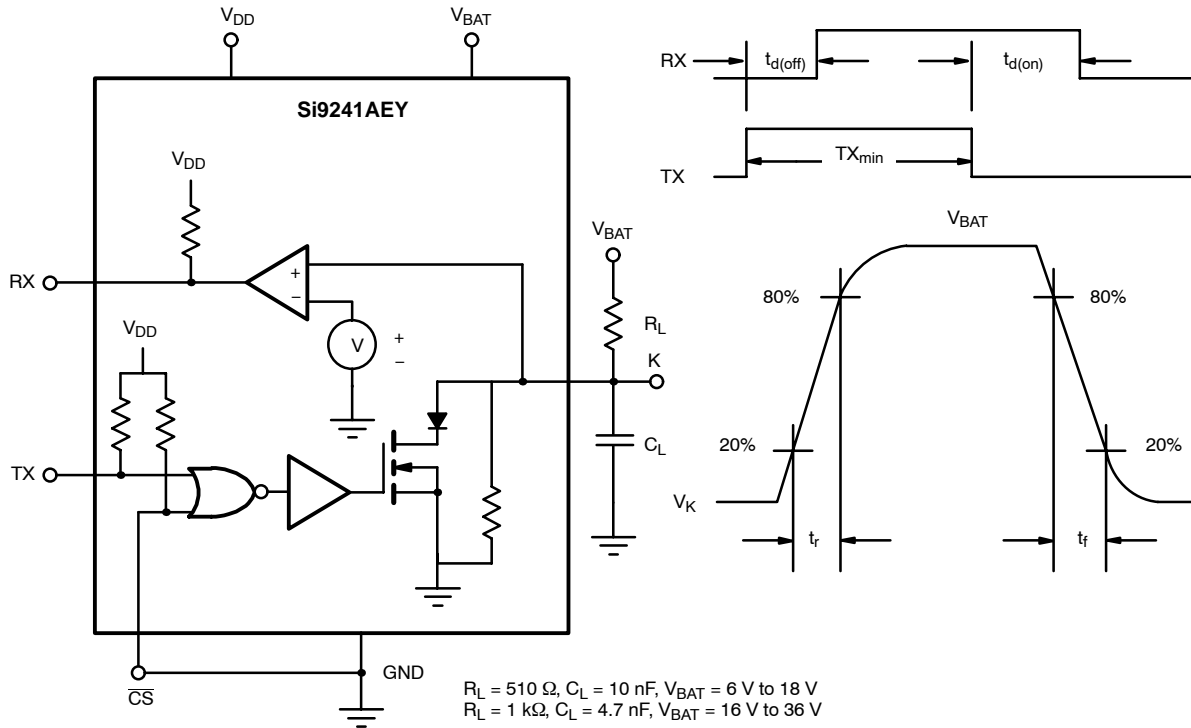

APPLICATION CIRCUIT

