

Over-The-Top Micropower, Rail-To-Rail Input and Output Op Amp

FEATURES

- Operates with Inputs Above V^+
- Rail-to-Rail Input and Output
- Micropower: 250μA Supply Current Max
- Tiny 3mm × 3mm × 0.8mm DFN Package
- Operating Temperature Range: -40°C to 125°C
- Gain-Bandwidth Product: 1.1MHz
- Slew Rate: 0.4V/μs
- Low Input Offset Voltage: 350μV Max
- Single Supply Input Range: -0.4V to 44V
- High Output Current: 25mA Min
- Specified on 3V, 5V and $\pm 15\text{V}$ Supplies
- Output Shutdown
- Output Drives 4700pF with Output Compensation
- Reverse Battery Protection to 25V
- High Voltage Gain: 800V/mV
- High CMRR: 110dB

APPLICATIONS

- Battery or Solar Powered Systems:
 - Portable Instrumentation
 - Sensor Conditioning
- Supply Current Sensing
- Battery Monitoring
- MUX Amplifiers
- 4mA to 25mA Transmitters

DESCRIPTION

The LT[®]1637 is a rugged op amp that operates on all single and split supplies with a total voltage of 2.7V to 44V. The LT1637 has a gain-bandwidth product of 1.1MHz while drawing less than 250μA of quiescent current. The LT1637 can be shut down, making the output high impedance and reducing the quiescent current to only 3μA. The LT1637 is reverse supply protected: it draws virtually no current for reverse supply up to 25V. The input range of the LT1637 includes both supplies and the output swings to both supplies. Unlike most micropower op amps, the LT1637 can drive heavy loads; its rail-to-rail output drives 25mA. The LT1637 is unity-gain stable into all capacitive loads up to 4700pF when optional 0.22μF and 150Ω compensation is used.

The LT1637 has a unique input stage that operates and remains high impedance when above the positive supply. The inputs take 44V both differential and common mode, even when operating on a 3V supply. Built-in resistors protect the inputs for faults below the negative supply up to 22V. There is no phase reversal of the output for inputs 5V below V_{EE} or 44V above V_{EE} , independent of V_{CC} .

The LT1637 op amp is available in the 8-pin MSOP, PDIP and SO packages. For space limited applications, the LT1637 is available in a 3mm × 3mm × 0.8mm dual fine pitch leadless package (DFN).

LT, LTC and LT are registered trademarks of Linear Technology Corporation. Over-The-Top is a registered trademark of Linear Technology Corporation.

TYPICAL APPLICATION

Over-The-Top[®] Current Source with Shutdown

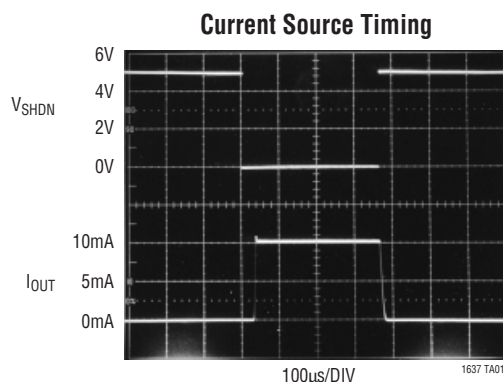
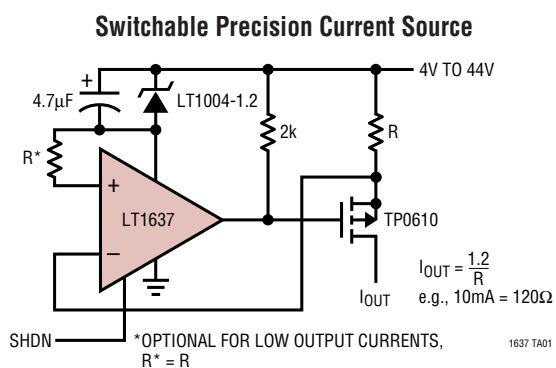

ABSOLUTE MAXIMUM RATINGS

(Note 1)

Total Supply Voltage (V^+ to V^-)	44V	Specified Temperature Range (Note 4)	
Input Differential Voltage	44V	LT1637C/LT1637I	-40°C to 85°C
Input Current	±25mA	LT1637H	-40°C to 125°C
Shutdown Pin Voltage Above V^-	32V	Junction Temperature	150°C
Shutdown Pin Current	±10mA	Junction Temperature (DD Package)	125°C
Output Short-Circuit Duration (Note 2)	Continuous	Storage Temperature Range	-65°C to 150°C
Operating Temperature Range (Note 3)		Storage Temperature Range	
LT1637C/LT1637I	-40°C to 85°C	(DD Package)	-65°C to 125°C
LT1637H	-40°C to 125°C	Lead Temperature (Soldering, 10 sec)	300°C

PACKAGE/ORDER INFORMATION

<p>DD PACKAGE 8-LEAD (3mm × 3mm) PLASTIC DFN $T_{JMAX} = 125^{\circ}\text{C}$, $\theta_{JA} = 160^{\circ}\text{C/W}$ (NOTE 2) UNDERSIDE METAL CONNECTED TO V^-</p>		<p>MS8 PACKAGE 8-LEAD PLASTIC MSOP $T_{JMAX} = 150^{\circ}\text{C}$, $\theta_{JA} = 250^{\circ}\text{C/W}$</p>		<p>N8 PACKAGE 8-LEAD PDIP S8 PACKAGE 8-LEAD PLASTIC SO $T_{JMAX} = 150^{\circ}\text{C}$, $\theta_{JA} = 150^{\circ}\text{C/W}$ (N8) $T_{JMAX} = 150^{\circ}\text{C}$, $\theta_{JA} = 190^{\circ}\text{C/W}$ (S8)</p>	
ORDER PART NUMBER	DD PART* MARKING	ORDER PART NUMBER	MS8 PART MARKING	ORDER PART NUMBER	S8 PART MARKING
LT1637CDD LT1637IDD	LAAK	LT1637CMS8	LTIE	LT1637CN8 LT1637CS8 LT1637IN8 LT1637IS8 LT1637HS8	1637 1637I 1637H

*The temperature grades are identified by a label on the shipping container. Consult factory for parts specified with wider operating temperature ranges.

3V AND 5V ELECTRICAL CHARACTERISTICS

The ● denotes the specifications which apply over the full operating temperature range of $-40^{\circ}\text{C} \leq T_A \leq 85^{\circ}\text{C}$, otherwise specifications are at $T_A = 25^{\circ}\text{C}$. $V_S = 3\text{V}$, 0V; $V_S = 5\text{V}$, 0V; $V_{SHDN} = V^-$, $V_{CM} = V_{OUT} = \text{half supply unless otherwise specified. (Note 4)}$

SYMBOL	PARAMETER	CONDITIONS	LT1637C/LT1637I			UNITS
			MIN	TYP	MAX	
V_{OS}	Input Offset Voltage	N8, S8 Packages $0^{\circ}\text{C} \leq T_A \leq 70^{\circ}\text{C}$ $-40^{\circ}\text{C} \leq T_A \leq 85^{\circ}\text{C}$	●	100	350	μV
			●		550	μV
			●		700	μV
		MS8 Package $0^{\circ}\text{C} \leq T_A \leq 70^{\circ}\text{C}$ $-40^{\circ}\text{C} \leq T_A \leq 85^{\circ}\text{C}$	●	100	350	μV
			●		750	μV
			●		900	μV
DD Package $0^{\circ}\text{C} \leq T_A \leq 70^{\circ}\text{C}$ $-40^{\circ}\text{C} \leq T_A \leq 85^{\circ}\text{C}$	●	125	550	μV		
	●		950	μV		
	●		1100	μV		

1637fb

3V AND 5V ELECTRICAL CHARACTERISTICS

The ● denotes the specifications which apply over the full operating temperature range of $-40^{\circ}\text{C} \leq T_A \leq 85^{\circ}\text{C}$, otherwise specifications are at $T_A = 25^{\circ}\text{C}$. $V_S = 3\text{V}, 0\text{V}$; $V_S = 5\text{V}, 0\text{V}$; $V_{\text{SHDN}} = V^-$, $V_{\text{CM}} = V_{\text{OUT}} = \text{half supply unless otherwise specified. (Note 4)}$

SYMBOL	PARAMETER	CONDITIONS	LT1637C/LT1637I			UNITS
			MIN	TYP	MAX	
	Input Offset Voltage Drift (Note 9)	N8, S8 Packages, $-40^{\circ}\text{C} \leq T_A \leq 85^{\circ}\text{C}$ MS8 Package, $-40^{\circ}\text{C} \leq T_A \leq 85^{\circ}\text{C}$ DDPackage, $-40^{\circ}\text{C} \leq T_A \leq 85^{\circ}\text{C}$	● ● ●	1 2 2	3 6 6	$\mu\text{V}/^{\circ}\text{C}$ $\mu\text{V}/^{\circ}\text{C}$ $\mu\text{V}/^{\circ}\text{C}$
I_{OS}	Input Offset Current	$V_{\text{CM}} = 44\text{V}$ (Note 5)	● ●	0.4	6.0 2.5	nA μA
I_{B}	Input Bias Current	$V_{\text{CM}} = 44\text{V}$ (Note 5) $V_S = 0\text{V}$	● ●	20 23 0.1	50 60	nA μA nA
	Input Noise Voltage	0.1Hz to 10Hz		0.6		$\mu\text{V}_{\text{P-P}}$
e_{n}	Input Noise Voltage Density	$f = 1\text{kHz}$		27		$\text{nV}/\sqrt{\text{Hz}}$
i_{n}	Input Noise Current Density	$f = 1\text{kHz}$		0.08		$\text{pA}/\sqrt{\text{Hz}}$
R_{IN}	Input Resistance	Differential Common Mode, $V_{\text{CM}} = 0\text{V}$ to 44V		1 0.7	2.6 1.4	$\text{M}\Omega$ $\text{M}\Omega$
C_{IN}	Input Capacitance			4		pF
	Input Voltage Range		●	0	44	V
CMRR	Common Mode Rejection Ratio (Note 5)	$V_{\text{CM}} = 0\text{V}$ to $(V_{\text{CC}} - 1\text{V})$ $V_{\text{CM}} = 0\text{V}$ to 44V (Note 8)	● ●	88 80	110 98	dB dB
A_{VOL}	Large-Signal Voltage Gain	$V_S = 3\text{V}, V_O = 500\text{mV}$ to 2.5V, $R_L = 10\text{k}$ $V_S = 3\text{V}, 0^{\circ}\text{C} \leq T_A \leq 70^{\circ}\text{C}$ $V_S = 3\text{V}, -40^{\circ}\text{C} \leq T_A \leq 85^{\circ}\text{C}$ $V_S = 5\text{V}, V_O = 500\text{mV}$ to 4.5V, $R_L = 10\text{k}$ $V_S = 5\text{V}, 0^{\circ}\text{C} \leq T_A \leq 70^{\circ}\text{C}$ $V_S = 5\text{V}, -40^{\circ}\text{C} \leq T_A \leq 85^{\circ}\text{C}$	● ● ● ● ● ●	150 100 75 300 200 150	400	V/mV V/mV V/mV V/mV V/mV V/mV
V_{OL}	Output Voltage Swing LOW	No Load $I_{\text{SINK}} = 5\text{mA}$ $V_S = 5\text{V}, I_{\text{SINK}} = 10\text{mA}$	● ● ●		3 8 325 700 580 1300	mV mV mV
V_{OH}	Output Voltage Swing HIGH	$V_S = 3\text{V}$, No Load $V_S = 3\text{V}, I_{\text{SOURCE}} = 5\text{mA}$ $V_S = 5\text{V}$, No Load $V_S = 5\text{V}, I_{\text{SOURCE}} = 10\text{mA}$	● ● ● ●	2.94 2.25 4.94 3.80	2.975 2.67 4.975 4.45	V V V V
I_{SC}	Short-Circuit Current (Note 2)	$V_S = 3\text{V}$, Short Output to Ground $V_S = 3\text{V}$, Short Output to V_{CC} $V_S = 5\text{V}$, Short Output to Ground $V_S = 5\text{V}$, Short Output to V_{CC}		10 15 15 15	14 45 22 60	mA mA mA mA
PSRR	Power Supply Rejection Ratio	$V_S = 3\text{V}$ to 12.5V, $V_{\text{CM}} = V_O = 1\text{V}$	●	90	98	dB
	Minimum Supply Voltage		●		2.7	V
	Reverse Supply Voltage	$I_S = -100\mu\text{A}$	●	25	40	V
I_S	Supply Current (Note 6)			190	250 295	μA μA
	Supply Current, SHDN	$V_{\text{PIN5}} = 2\text{V}$, No Load (Note 6)	●	3	12	μA
I_{SHDN}	Shutdown Pin Current	$V_{\text{PIN5}} = 0.3\text{V}$, No Load (Note 6) $V_{\text{PIN5}} = 2\text{V}$, No Load (Note 5) $V_{\text{PIN5}} = 3.3\text{V}$ $V_{\text{PIN5}} = 5\text{V}$	● ●	0.2 1.0 2.5 4.3	15 5	nA μA μA μA
	Output Leakage Current, SHDN	$V_{\text{PIN5}} = 2\text{V}$, No Load (Note 6)	●	0.02	1	μA

3V AND 5V ELECTRICAL CHARACTERISTICS

The ● denotes the specifications which apply over the full operating temperature range of $-40^{\circ}\text{C} \leq T_A \leq 85^{\circ}\text{C}$, otherwise specifications are at $T_A = 25^{\circ}\text{C}$. $V_S = 3\text{V}, 0\text{V}$; $V_S = 5\text{V}, 0\text{V}$; $V_{\text{SHDN}} = V^-$, $V_{\text{CM}} = V_{\text{OUT}} = \text{half supply}$ unless otherwise specified. (Note 4)

SYMBOL	PARAMETER	CONDITIONS	LT1637C/LT1637I			UNITS
			MIN	TYP	MAX	
	Maximum Shutdown Pin Current	$V_{\text{PIN5}} = 32\text{V}$, No Load (Note 5)	●	20	150	μA
t_{ON}	Turn-On Time	$V_{\text{PIN5}} = 5\text{V}$ to 0V , $R_L = 10\text{k}$		45		μs
t_{OFF}	Turn-Off Time	$V_{\text{PIN5}} = 0\text{V}$ to 5V , $R_L = 10\text{k}$		3		μs
t_{SETTLING}	Settling Time	$0.1\% A_V = 1$, $\Delta V_O = 2\text{V}$		9		μs
GBW	Gain-Bandwidth Product (Note 5)	$f = 10\text{kHz}$		650	1000	kHz
		$0^{\circ}\text{C} \leq T_A \leq 70^{\circ}\text{C}$	●	550		kHz
		$-40^{\circ}\text{C} \leq T_A \leq 85^{\circ}\text{C}$	●	500		kHz
SR	Slew Rate (Note 7)	$A_V = -1$, $R_L = \infty$		0.210	0.35	$\text{V}/\mu\text{s}$
		$0^{\circ}\text{C} \leq T_A \leq 70^{\circ}\text{C}$	●	0.185		$\text{V}/\mu\text{s}$
		$-40^{\circ}\text{C} \leq T_A \leq 85^{\circ}\text{C}$	●	0.170		$\text{V}/\mu\text{s}$

$\pm 15\text{V}$ ELECTRICAL CHARACTERISTICS

The ● denotes the specifications which apply over the full operating temperature range of $-40^{\circ}\text{C} \leq T_A \leq 85^{\circ}\text{C}$, otherwise specifications are at $T_A = 25^{\circ}\text{C}$. $V_S = \pm 15\text{V}$, $V_{\text{CM}} = 0\text{V}$, $V_{\text{OUT}} = 0\text{V}$, $V_{\text{SHDN}} = V^-$ unless otherwise specified. (Note 4)

SYMBOL	PARAMETER	CONDITIONS	LT1637C/LT1637I			UNITS
			MIN	TYP	MAX	
V_{OS}	Input Offset Voltage	N8, S8 Packages		100	450	μV
		$0^{\circ}\text{C} \leq T_A \leq 70^{\circ}\text{C}$	●		650	μV
		$-40^{\circ}\text{C} \leq T_A \leq 85^{\circ}\text{C}$	●		800	μV
		MS8 Package		100	450	μV
		$0^{\circ}\text{C} \leq T_A \leq 70^{\circ}\text{C}$	●		800	μV
		$-40^{\circ}\text{C} \leq T_A \leq 85^{\circ}\text{C}$	●		950	μV
	Input Offset Voltage Drift (Note 9)	DD Package		125	650	μV
		$0^{\circ}\text{C} \leq T_A \leq 70^{\circ}\text{C}$	●		1000	μV
		$-40^{\circ}\text{C} \leq T_A \leq 85^{\circ}\text{C}$	●		1150	μV
		N8, S8 Packages, $-40^{\circ}\text{C} \leq T_A \leq 85^{\circ}\text{C}$	●	1	3	$\mu\text{V}/^{\circ}\text{C}$
		MS8 Package, $-40^{\circ}\text{C} \leq T_A \leq 85^{\circ}\text{C}$	●	2	6	$\mu\text{V}/^{\circ}\text{C}$
		DD Package, $-40^{\circ}\text{C} \leq T_A \leq 85^{\circ}\text{C}$	●	2	6	$\mu\text{V}/^{\circ}\text{C}$
I_{OS}	Input Offset Current		●	1	6	nA
I_{B}	Input Bias Current		●	17	50	nA
	Input Noise Voltage	0.1Hz to 10Hz		0.6		$\mu\text{V}_{\text{p-p}}$
e_{n}	Input Noise Voltage Density	$f = 1\text{kHz}$		27		$\text{nV}/\sqrt{\text{Hz}}$
i_{n}	Input Noise Current Density	$f = 1\text{kHz}$		0.08		$\text{pA}/\sqrt{\text{Hz}}$
R_{IN}	Input Resistance	Differential		1	3	$\text{M}\Omega$
		Common Mode, $V_{\text{CM}} = -15\text{V}$ to 14V			2200	$\text{M}\Omega$
C_{IN}	Input Capacitance			4		pF
	Input Voltage Range		●	-15	29	V
CMRR	Common Mode Rejection Ratio	$V_{\text{CM}} = -15\text{V}$ to 29V	●	80	110	dB
A_{VOL}	Large-Signal Voltage Gain	$V_O = \pm 14\text{V}$, $R_L = 10\text{k}$		100	400	V/mV
		$0^{\circ}\text{C} \leq T_A \leq 70^{\circ}\text{C}$	●	75		V/mV
		$-40^{\circ}\text{C} \leq T_A \leq 85^{\circ}\text{C}$	●	50		V/mV
V_{OL}	Output Voltage Swing LOW	No Load	●	-14.997	-14.95	V
		$I_{\text{SINK}} = 5\text{mA}$	●	-14.680	-14.25	V
		$I_{\text{SINK}} = 10\text{mA}$	●	-14.420	-13.65	V

±15V ELECTRICAL CHARACTERISTICS

The ● denotes the specifications which apply over the full operating temperature range of $-40^{\circ}\text{C} \leq T_A \leq 85^{\circ}\text{C}$, otherwise specifications are at $T_A = 25^{\circ}\text{C}$. $V_S = \pm 15\text{V}$, $V_{\text{CM}} = 0\text{V}$, $V_{\text{OUT}} = 0\text{V}$, $V_{\text{SHDN}} = V^-$ unless otherwise specified. (Note 4)

SYMBOL	PARAMETER	CONDITIONS	LT1637C/LT1637I			UNITS
			MIN	TYP	MAX	
V_{OH}	Output Voltage Swing HIGH	No Load	● 14.9	14.967		V
		$I_{\text{SOURCE}} = 5\text{mA}$	● 14.2	14.667		V
		$I_{\text{SOURCE}} = 10\text{mA}$	● 13.7	14.440		V
I_{SC}	Short-Circuit Current (Note 2)	Short Output to GND	● ± 25	± 31.7		mA
		$0^{\circ}\text{C} \leq T_A \leq 70^{\circ}\text{C}$	● ± 20			mA
		$-40^{\circ}\text{C} \leq T_A \leq 85^{\circ}\text{C}$	● ± 15			mA
PSRR	Power Supply Rejection Ratio	$V_S = \pm 1.5\text{V}$ to $\pm 22\text{V}$	● 90	115		dB
	Minimum Supply Voltage				± 1.35	V
I_S	Supply Current			230	300	μA
			●		370	μA
	Positive Supply Current, SHDN	$V_{\text{PIN5}} = -20\text{V}$, $V_S = \pm 22\text{V}$, No Load	●	6	40	μA
I_{SHDN}	Shutdown Pin Current	$V_{\text{PIN5}} = -21.7\text{V}$, $V_S = \pm 22\text{V}$, No Load	●	0.3	15	nA
		$V_{\text{PIN5}} = -20\text{V}$, $V_S = \pm 22\text{V}$, No Load	●	0.9	8	μA
	Maximum Shutdown Pin Current	$V_{\text{PIN5}} = 32\text{V}$, $V_S = \pm 22\text{V}$	●	20	150	μA
	Output Leakage Current, SHDN	$V_{\text{PIN5}} = -20\text{V}$, $V_S = \pm 22\text{V}$, No Load	●	0.02	2	μA
V_L	Shutdown Pin Input Low Voltage	$V_S = \pm 22\text{V}$	● -21.7	-21.6		V
V_H	Shutdown Pin Input High Voltage	$V_S = \pm 22\text{V}$	●	-20.8	-20.0	V
t_{ON}	Turn-On Time	$V_{\text{PIN5}} = -10\text{V}$ to -15V , $R_L = 10\text{k}$		35		μs
t_{OFF}	Turn-Off Time	$V_{\text{PIN5}} = -15\text{V}$ to -10V , $R_L = 10\text{k}$		3		μs
GBW	Gain-Bandwidth Product	$f = 10\text{kHz}$	● 750	1100		kHz
		$0^{\circ}\text{C} \leq T_A \leq 70^{\circ}\text{C}$	● 650			kHz
		$-40^{\circ}\text{C} \leq T_A \leq 85^{\circ}\text{C}$	● 600			kHz
SR	Slew Rate	$A_V = -1$, $R_L = \infty$, $V_0 = \pm 10\text{V}$, Measure at $V_0 = \pm 5\text{V}$	● 0.225	0.4		V/ μs
		$0^{\circ}\text{C} \leq T_A \leq 70^{\circ}\text{C}$	● 0.200			V/ μs
		$-40^{\circ}\text{C} \leq T_A \leq 85^{\circ}\text{C}$	● 0.180			V/ μs

3V AND 5V ELECTRICAL CHARACTERISTICS

The ● denotes the specifications which apply over the full operating temperature range of $-40^{\circ}\text{C} \leq T_A \leq 125^{\circ}\text{C}$.
 $V_S = 3\text{V}, 0\text{V}$; $V_S = 5\text{V}, 0\text{V}$; $V_{CM} = V_{OUT} = \text{half supply unless otherwise specified. (Note 4)}$

SYMBOL	PARAMETER	CONDITIONS	LT1637H			UNITS
			MIN	TYP	MAX	
V_{OS}	Input Offset Voltage		●	100	450	μV
	Input Offset Voltage Drift (Note 9)		●	3	10	$\mu\text{V}/^{\circ}\text{C}$
I_{OS}	Input Offset Current	$V_{CM} = 44\text{V}$ (Note 5)	●		15	nA
			●		10	μA
I_B	Input Bias Current	$V_{CM} = 44\text{V}$ (Note 5)	●		150	nA
			●		100	μA
	Input Voltage Range		●	0.3	44	V
CMRR	Common Mode Rejection Ratio (Note 5)	$V_{CM} = 0.3\text{V}$ to $(V_{CC} - 1\text{V})$	●	72		dB
		$V_{CM} = 0.3\text{V}$ to 44V	●	74		dB
A_{VOL}	Large-Signal Voltage Gain	$V_S = 3\text{V}, V_O = 500\text{mV}$ to $2.5\text{V}, R_L = 10\text{k}$	●	150	400	V/mV
		$V_S = 5\text{V}, V_O = 500\text{mV}$ to $4.5\text{V}, R_L = 10\text{k}$	●	20	800	V/mV
V_{OL}	Output Voltage Swing LOW	No Load	●		15	mV
		$I_{SINK} = 5\text{mA}$	●		900	mV
		$V_S = 5\text{V}, I_{SINK} = 10\text{mA}$	●		1500	mV
V_{OH}	Output Voltage Swing HIGH	$V_S = 3\text{V}$, No Load	●	2.90		V
		$V_S = 3\text{V}, I_{SOURCE} = 5\text{mA}$	●	2.05		V
		$V_S = 5\text{V}$, No Load	●	4.90		V
		$V_S = 5\text{V}, I_{SOURCE} = 10\text{mA}$	●	3.50		V
PSRR	Power Supply Rejection Ratio	$V_S = 3\text{V}$ to $12.5\text{V}, V_{CM} = V_O = 1\text{V}$	●	80		dB
	Minimum Supply Voltage		●	2.7		V
	Reverse Supply Voltage	$I_S = -100\mu\text{A}$	●	23		V
I_S	Supply Current	(Note 6)	●	190	250	μA
	Supply Current, SHDN	$V_{PIN5} = 2\text{V}$, No Load (Note 6)	●		400	μA
I_{SHDN}	Shutdown Pin Current	$V_{PIN5} = 0.3\text{V}$, No Load (Note 6)	●		15	μA
		$V_{PIN5} = 2\text{V}$, No Load (Note 5)	●		200	nA
	Output Leakage Current, SHDN	$V_{PIN5} = 2\text{V}$, No Load (Note 6)	●		7	μA
	Maximum Shutdown Pin Current	$V_{PIN5} = 32\text{V}$, No Load (Note 5)	●		5	μA
GBW	Gain-Bandwidth Product	$f = 10\text{kHz}$ (Note 5)	●	650	1000	kHz
			●	350		kHz
SR	Slew Rate	$A_V = -1, R_L = \infty$ (Note 7)	●	0.210	0.35	V/ μs
			●	0.1		V/ μs

±15V ELECTRICAL CHARACTERISTICS

The ● denotes the specifications which apply over the full operating temperature range of $-40^{\circ}\text{C} \leq T_A \leq 125^{\circ}\text{C}$. $V_S = \pm 15\text{V}$, $V_{\text{CM}} = 0\text{V}$, $V_{\text{OUT}} = 0\text{V}$, $V_{\text{SHDN}} = V^-$, $T_A = -40^{\circ}\text{C}$ to 125°C , unless otherwise specified. (Note 4)

SYMBOL	PARAMETER	CONDITIONS	LT1637H			UNITS
			MIN	TYP	MAX	
V_{OS}	Input Offset Voltage		●	100	550 3.4	μV mV
	Input Offset Voltage Drift (Note 9)		●	3	11	$\mu\text{V}/^{\circ}\text{C}$
I_{OS}	Input Offset Current		●		25	nA
I_{B}	Input Bias Current		●		250	nA
CMRR	Common Mode Rejection Ratio	$V_{\text{CM}} = -14.7\text{V}$ to 29V	●	72		dB
A_{VOL}	Large-Signal Voltage Gain	$V_0 = \pm 14\text{V}$, $R_L = 10\text{k}$	●	100 4	400	V/mV V/mV
V_0	Output Voltage Swing	No Load	●		± 14.8	V
		$I_{\text{OUT}} = \pm 5\text{mA}$	●		± 14.0	V
		$I_{\text{OUT}} = \pm 10\text{mA}$	●		± 13.4	V
PSRR	Power Supply Rejection Ratio	$V_S = \pm 1.5\text{V}$ to 22V	●	84		dB
	Minimum Supply Voltage		●	± 1.35		V
I_S	Supply Current		●	230	300 500	μA μA
	Positive Supply Current, SHDN	$V_{\text{PIN5}} = -20\text{V}$, $V_S = \pm 22\text{V}$, No Load	●		60	μA
	I_{SHDN}	Shutdown Pin Current	$V_{\text{PIN5}} = -21.7\text{V}$, $V_S = \pm 22\text{V}$, No Load	●		200
$V_{\text{PIN5}} = -20\text{V}$, $V_S = \pm 22\text{V}$, No Load			●		10	μA
	Maximum Shutdown Pin Current	$V_{\text{PIN5}} = 32\text{V}$, $V_S = \pm 22\text{V}$	●		200	μA
	Output Leakage Current, SHDN	$V_{\text{PIN5}} = -20\text{V}$, $V_S = \pm 22\text{V}$, No Load	●		100	μA
V_L	Shutdown Pin Input Low Voltage	$V_S = \pm 22\text{V}$	●		-21.7	V
V_H	Shutdown Pin Input High Voltage	$V_S = \pm 22\text{V}$	●	-20		V
GBW	Gain-Bandwidth Product	$f = 10\text{kHz}$	●	750	1100	kHz
			●	400		kHz
SR	Slew Rate	$A_V = -1$, $R_L = \infty$, $V_0 = \pm 10\text{V}$, Measure at $V_0 = \pm 5\text{V}$	●	0.225	0.4	$\text{V}/\mu\text{s}$
			●	0.1		$\text{V}/\mu\text{s}$

Note 1: Absolute Maximum Ratings are those values beyond which the life of a device may be impaired.

Note 2: A heat sink may be required to keep the junction temperature below absolute maximum. The θ_{JA} specified for the DD package is with minimal PCB heat spreading metal. Using expanded metal area on all layers of a board reduces this value.

Note 3: The LT1637C and LT1637I are guaranteed functional over the operating temperature range of -40°C to 85°C . The LT1637H is guaranteed functional over the operating temperature range of -40°C to 125°C .

Note 4: The LT1637C is guaranteed to meet specified performance from 0°C to 70°C . The LT1637C is designed, characterized and expected to meet specified performance from -40°C to 85°C but is not tested or QA sampled

at these temperatures. The LT1637I is guaranteed to meet specified performance from -40°C to 85°C . The LT1637H is guaranteed to meet specified performance from -40°C to 125°C .

Note 5: $V_S = 5\text{V}$ limits are guaranteed by correlation to $V_S = 3\text{V}$ and $V_S = \pm 15\text{V}$ or $V_S = \pm 22\text{V}$ tests.

Note 6: $V_S = 3\text{V}$ limits are guaranteed by correlation to $V_S = 5\text{V}$ and $V_S = \pm 15\text{V}$ or $V_S = \pm 22\text{V}$ tests.

Note 7: Guaranteed by correlation to slew rate at $V_S = \pm 15\text{V}$ and GBW at $V_S = 3\text{V}$ and $V_S = \pm 15\text{V}$ tests.

Note 8: This specification implies a typical input offset voltage of $650\mu\text{V}$ at $V_{\text{CM}} = 44\text{V}$ and a maximum input offset voltage of 5.4mV at $V_{\text{CM}} = 44\text{V}$.

Note 9: This parameter is not 100% tested.

TYPICAL PERFORMANCE CHARACTERISTICS

Supply Current vs Supply Voltage

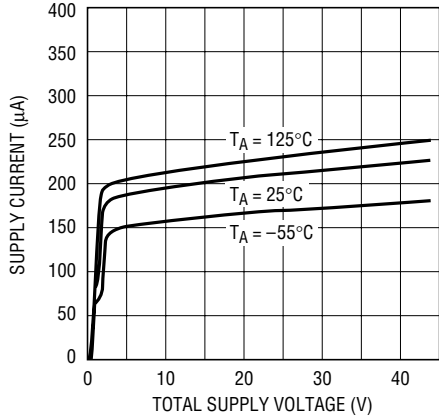

1637 G01

Minimum Supply Voltage

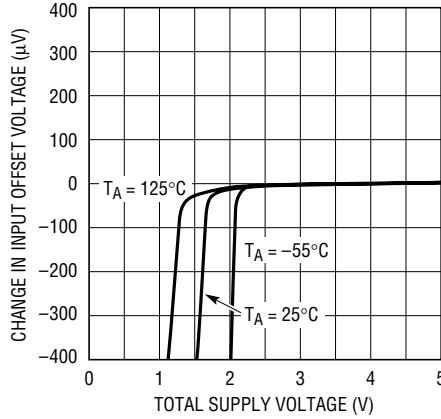

1637 G02

Input Bias Current vs Common Mode Voltage

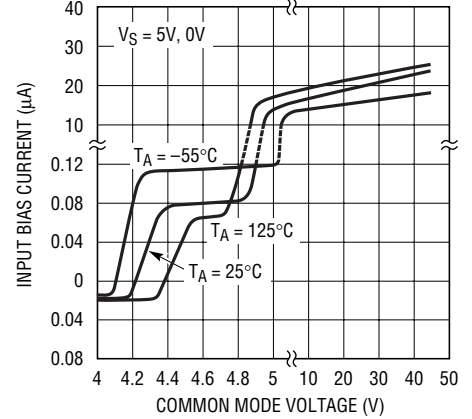

1637 G03

Output Saturation Voltage vs Load Current (Output High)

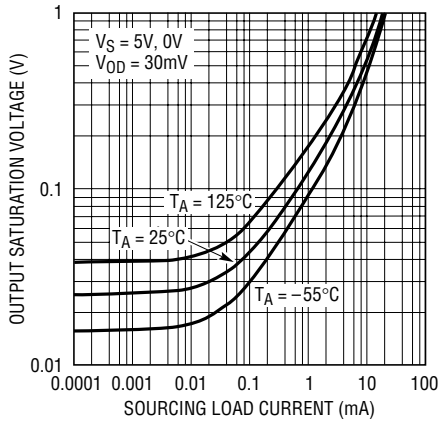

1637 G04

Output Saturation Voltage vs Load Current (Output Low)

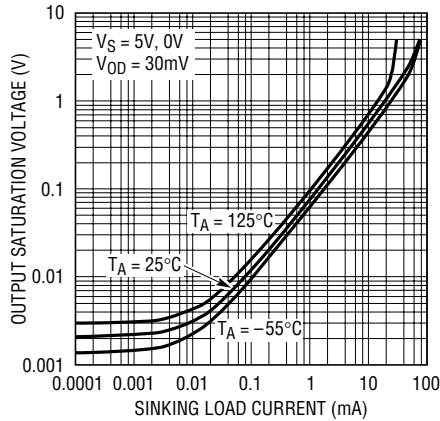

1637 G05

Output Saturation Voltage vs Input Overdrive

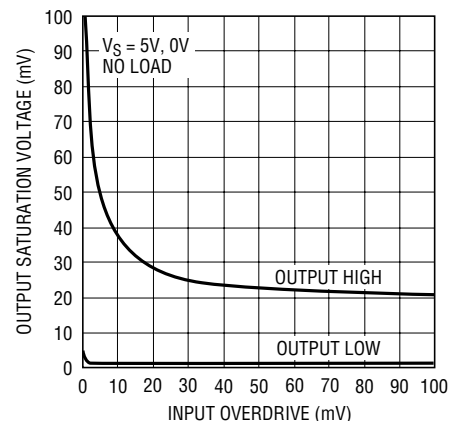

1637 G06

0.1Hz to 10Hz Noise Voltage

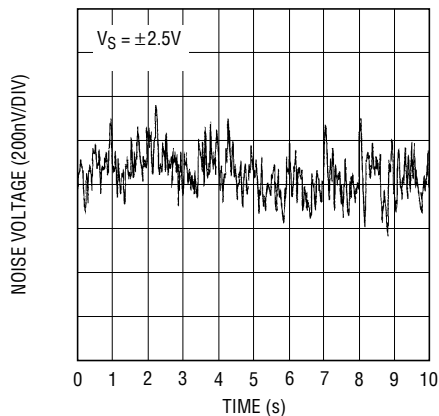

1637 G07

Noise Voltage Density vs Frequency

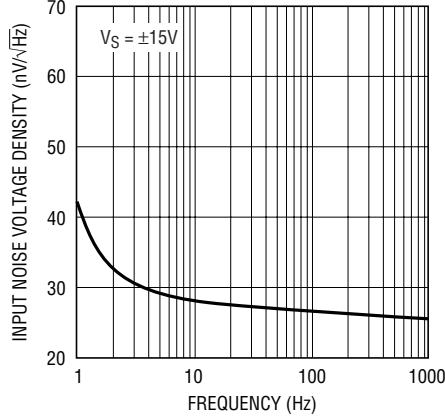

1637 G08

Input Noise Current vs Frequency

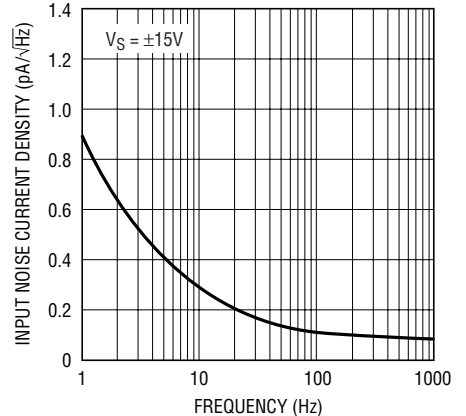

1637 G09

TYPICAL PERFORMANCE CHARACTERISTICS

Open-Loop Gain and Phase Shift vs Frequency

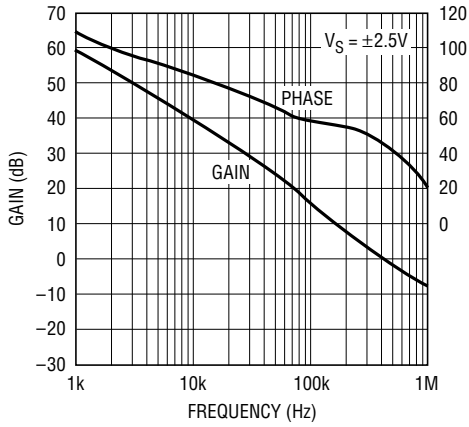

1637 G10

Gain-Bandwidth Product vs Temperature

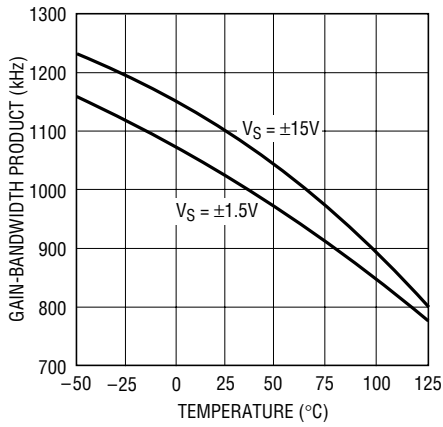

1637 G11

Slew Rate vs Temperature

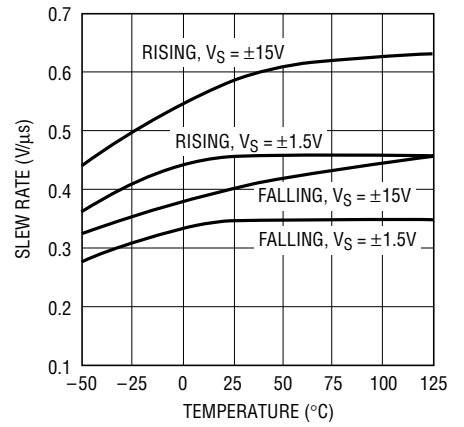

1637 G12

Gain-Bandwidth Product and Phase Margin vs Supply Voltage

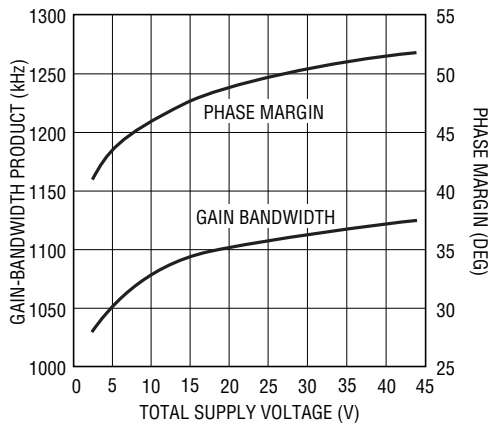

1637 G13

CMRR vs Frequency

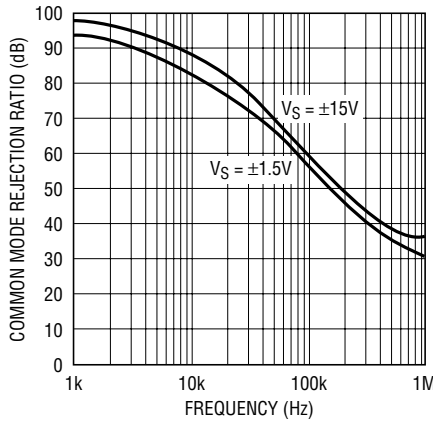

1637 G14

PSRR vs Frequency

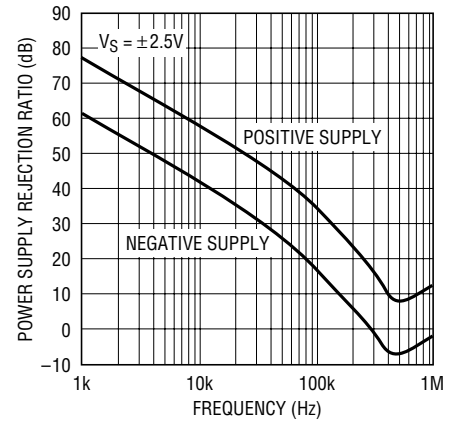

1637 G15

Gain-Bandwidth Product and Phase Margin vs Load Resistance

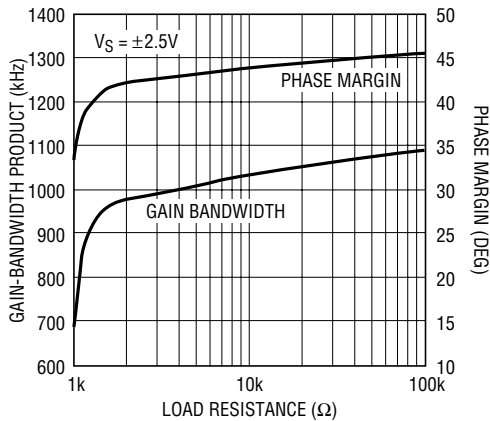

1637 G16

Output Impedance vs Frequency

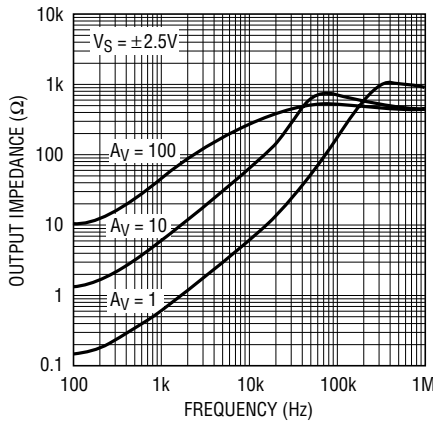

1637 G17

Undistorted Output Swing vs Frequency

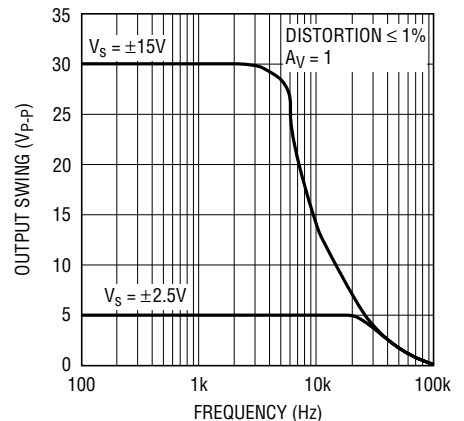

1637 G18

TYPICAL PERFORMANCE CHARACTERISTICS

Settling Time to 0.1% vs Output Step

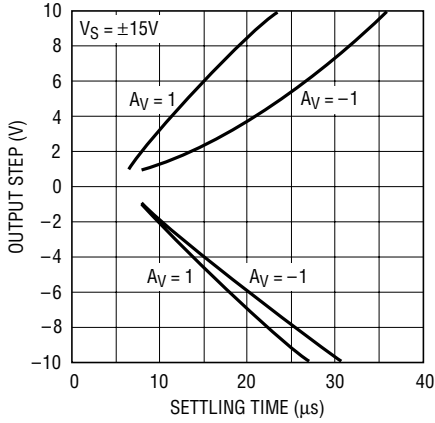

1637 G19

Capacitive Load Handling, Overshoot vs Capacitive Load

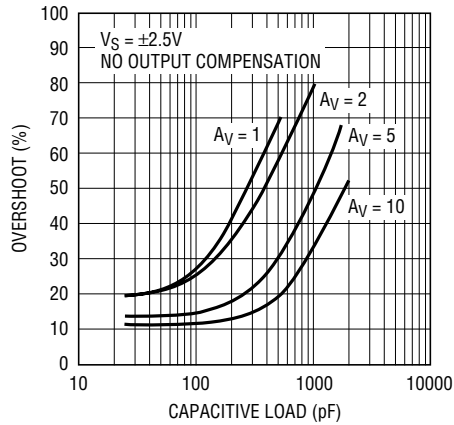

1637 G20

Total Harmonic Distortion + Noise vs Frequency

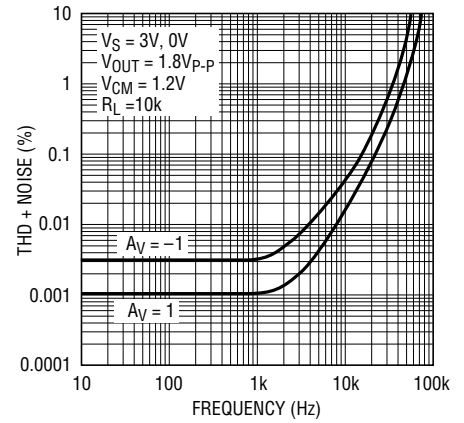

1637 G21

Total Harmonic Distortion + Noise vs Load Resistance

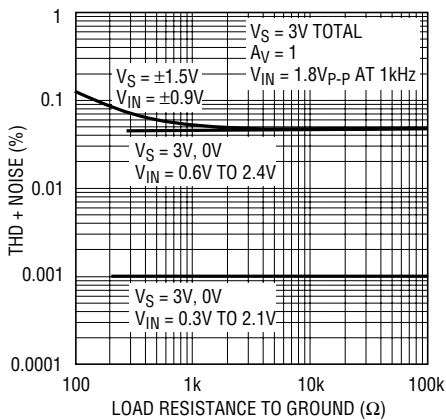

1637 G22

Total Harmonic Distortion + Noise vs Output Voltage

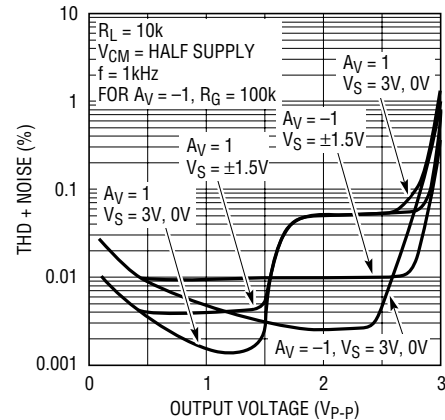

1637 G23

Open-Loop Gain

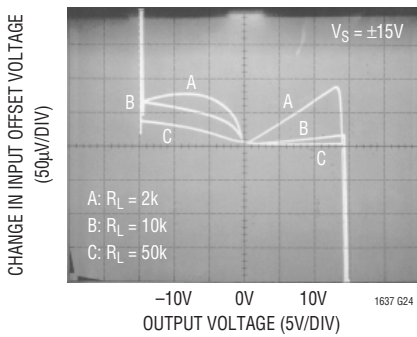

1637 G24

Large-Signal Response

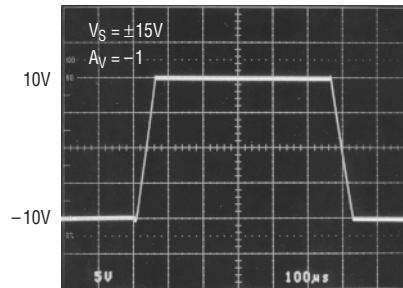

1637 G25

Small-Signal Response

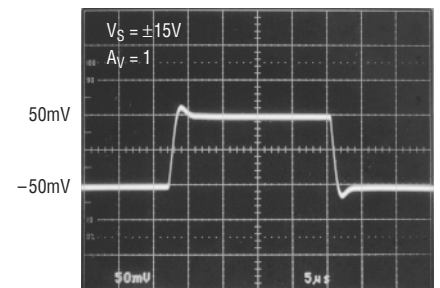

1637 G26

APPLICATIONS INFORMATION

Supply Voltage

The positive supply pin of the LT1637 should be bypassed with a small capacitor (about $0.01\mu\text{F}$) within an inch of the pin. When driving heavy loads an additional $4.7\mu\text{F}$ electrolytic capacitor should be used. When using split supplies, the same is true for the negative supply pin.

The LT1637 is protected against reverse battery voltages up to 25V. In the event a reverse battery condition occurs, the supply current is typically less than 1nA.

When operating the LT1637 on total supplies of 30V or more, the supply must not be brought up faster than $1\mu\text{s}$. This is especially true if low ESR bypass capacitors are used. A series RLC circuit is formed from the supply lead inductance and the bypass capacitor. 5Ω of resistance in the supply or the bypass capacitor will dampen the tuned circuit enough to limit the rise time.

Inputs

The LT1637 has two input stages, NPN and PNP (see the Simplified Schematic), resulting in three distinct operating regions as shown in the Input Bias Current vs Common Mode typical performance curve.

For input voltages about 0.9V or more below V^+ , the PNP input stage is active and the input bias current is typically -20nA . When the input voltage is about 0.5V or less from V^+ , the NPN input stage is operating and the input bias current is typically 80nA . Increases in temperature will cause the voltage at which operation switches from the PNP stage to the NPN stage to move towards V^+ . The input offset voltage of the NPN stage is untrimmed and is typically $600\mu\text{V}$.

A Schottky diode in the collector of each NPN transistor of the NPN input stage allows the LT1637 to operate with either or both of its inputs above V^+ . At about 0.3V above V^+ the NPN input transistor is fully saturated and the input bias current is typically $23\mu\text{A}$ at room temperature. The input offset voltage is typically $600\mu\text{V}$ when operating above V^+ . The LT1637 will operate with its input 44V above V^- regardless of V^+ .

The inputs are protected against excursions as much as 22V below V^- by an internal 1.3k resistor in series with each input and a diode from the input to the negative supply. There is no output phase reversal for inputs up to 5V below V^- . There are no clamping diodes between the inputs and the maximum differential input voltage is 44V.

Output

The output voltage swing of the LT1637 is affected by input overdrive as shown in the typical performance curves. When monitoring input voltages within 100mV of V^+ , gain should be taken to keep the output from clipping.

The output of the LT1637 can be pulled up to 25V beyond V^+ with less than 1nA of leakage current, provided that V^+ is less than 0.5V.

The normally reverse biased substrate diode from the output to V^- will cause unlimited currents to flow when the output is forced below V^- . If the current is transient and limited to 100mA, no damage will occur.

The LT1637 is internally compensated to drive at least 200pF of capacitance under any output loading conditions. A $0.22\mu\text{F}$ capacitor in series with a 150Ω resistor between the output and ground will compensate these amplifiers for larger capacitive loads, up to 4700pF, at all output currents.

Distortion

There are two main contributors of distortion in op amps: output crossover distortion as the output transitions from sourcing to sinking current and distortion caused by nonlinear common mode rejection. Of course, if the op amp is operating inverting there is no common mode induced distortion. When the LT1637 switches between input stages there is significant nonlinearity in the CMRR. Lower load resistance increases the output crossover distortion, but has no effect on the input stage transition distortion. For lowest distortion the LT1637 should be operated single supply, with the output always sourcing current and with the input voltage swing between ground and $(V^+ - 0.9\text{V})$. See the Typical Performance Characteristics curves.

APPLICATIONS INFORMATION

Gain

The open-loop gain is less sensitive to load resistance when the output is sourcing current. This optimizes performance in single supply applications where the load is returned to ground. The typical performance photo of Open-Loop Gain for various loads shows the details.

Shutdown

The LT1637 can be shut down two ways: using the shutdown pin or bringing V^+ to within 0.5V of V^- . When V^+ is brought to within 0.5V of V^- both the supply current and output leakage current drop to less than 10nA. When the shutdown pin is brought 1.2V above V^- , the supply current drops to about 3 μ A and the output leakage current is less than 1 μ A, independent of V^+ . In either case the input bias current is less than 0.1nA (even if the inputs are 44V above the negative supply).

The shutdown pin can be taken up to 32V above V^- . The shutdown pin can be driven below V^- , however the pin current through the substrate diode should be limited with an external resistor to less than 10mA.

Input Offset Nulling

The input offset voltage can be nulled by placing a 10k potentiometer between Pins 1 and 8 with its wiper to V^- (see Figure 1). The null range will be at least ± 3 mV.

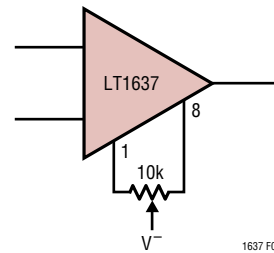
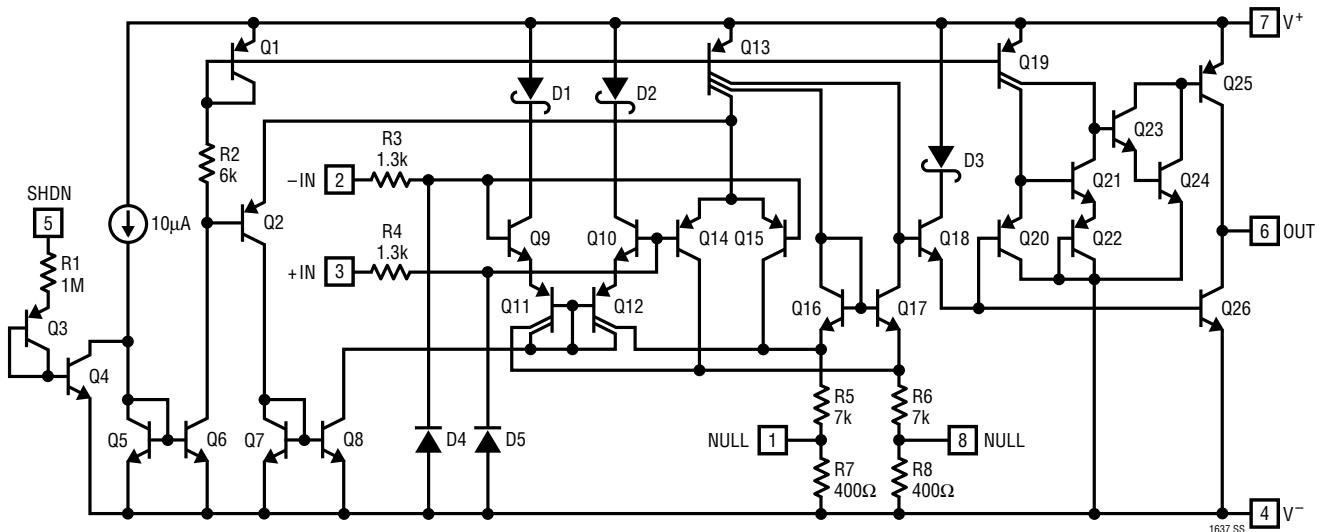

Figure 1. Input Offset Nulling

SIMPLIFIED SCHEMATIC



TYPICAL APPLICATIONS

Positive Supply Rail Current Sense

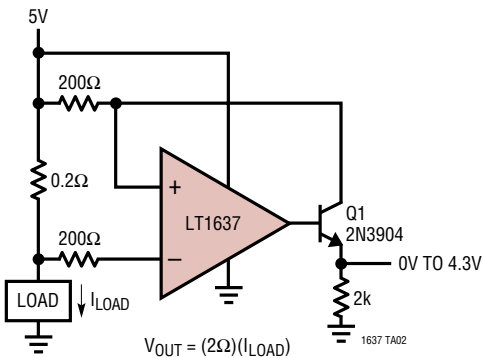

Optional Output Compensation for Capacitive Loads Greater Than 200pF

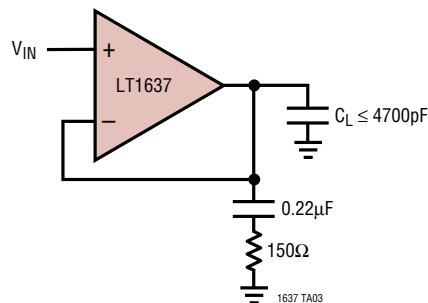

Lamp Outage Detector

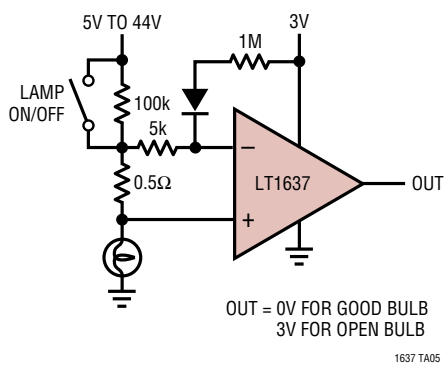

Over-The-Top Comparator with Hysteresis

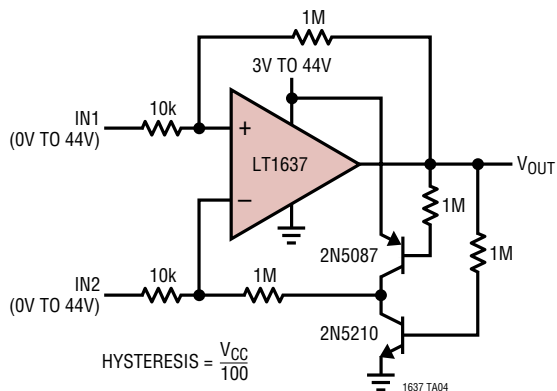

Over-The-Top Current Sense

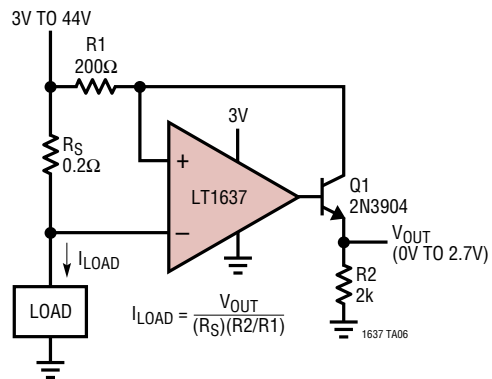

PACKAGE DESCRIPTION

DD Package 8-Lead Plastic DFN (3mm × 3mm) (Reference LTC DWG # 05-08-1698)

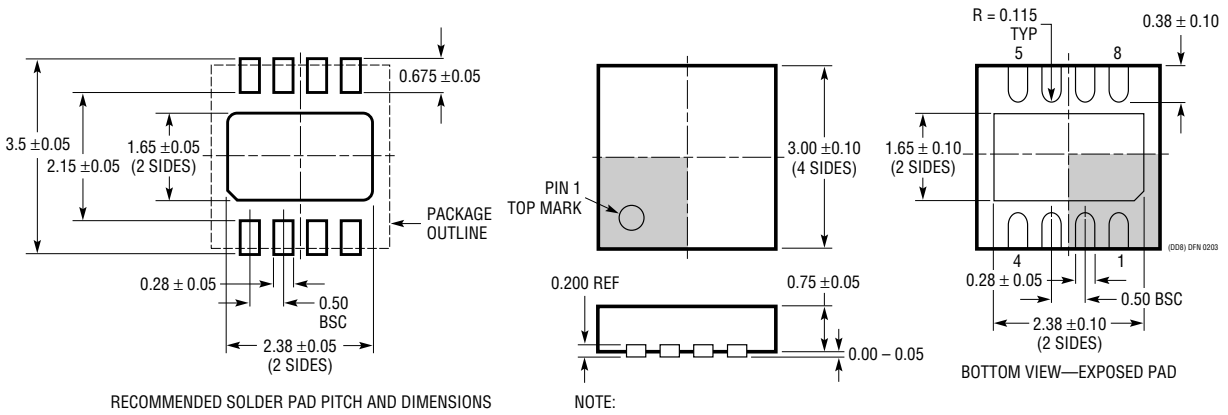

- NOTE:
1. DRAWING TO BE MADE A JEDEC PACKAGE OUTLINE M0-229 VARIATION OF (WEED-1)
 2. ALL DIMENSIONS ARE IN MILLIMETERS
 3. DIMENSIONS OF EXPOSED PAD ON BOTTOM OF PACKAGE DO NOT INCLUDE MOLD FLASH. MOLD FLASH, IF PRESENT, SHALL NOT EXCEED 0.15mm ON ANY SIDE
 4. EXPOSED PAD SHALL BE SOLDER PLATED

MS8 Package 8-Lead Plastic MSOP (Reference LTC DWG # 05-08-1660)

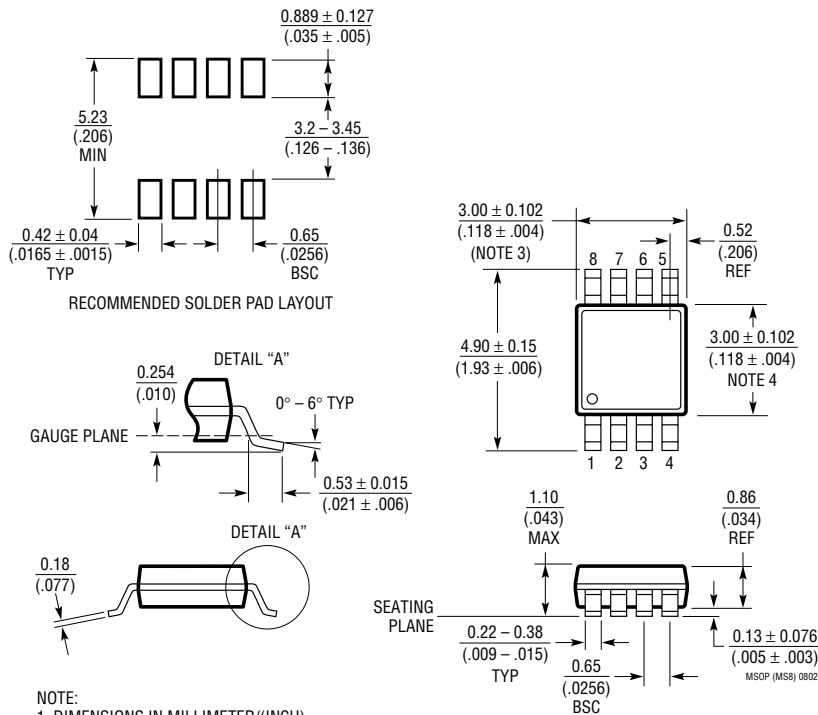

- NOTE:
1. DIMENSIONS IN MILLIMETER/(INCH)
 2. DRAWING NOT TO SCALE
 3. DIMENSION DOES NOT INCLUDE MOLD FLASH, PROTRUSIONS OR GATE BURRS. MOLD FLASH, PROTRUSIONS OR GATE BURRS SHALL NOT EXCEED 0.152mm (.006") PER SIDE
 4. DIMENSION DOES NOT INCLUDE INTERLEAD FLASH OR PROTRUSIONS. INTERLEAD FLASH OR PROTRUSIONS SHALL NOT EXCEED 0.152mm (.006") PER SIDE
 5. LEAD COPLANARITY (BOTTOM OF LEADS AFTER FORMING) SHALL BE 0.102mm (.004") MAX

PACKAGE DESCRIPTION

N8 Package 8-Lead PDIP (Narrow .300 Inch) (Reference LTC DWG # 05-08-1510)

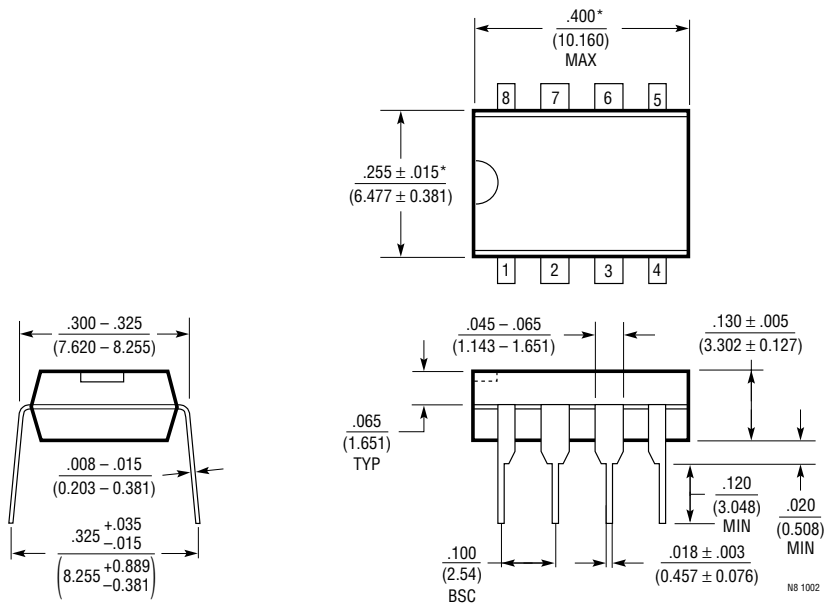

NOTE:
1. DIMENSIONS ARE $\frac{\text{INCHES}}{\text{MILLIMETERS}}$
*THESE DIMENSIONS DO NOT INCLUDE MOLD FLASH OR PROTRUSIONS.
MOLD FLASH OR PROTRUSIONS SHALL NOT EXCEED .010 INCH (0.254mm)

S8 Package 8-Lead Plastic Small Outline (Narrow .150 Inch) (Reference LTC DWG # 05-08-1610)

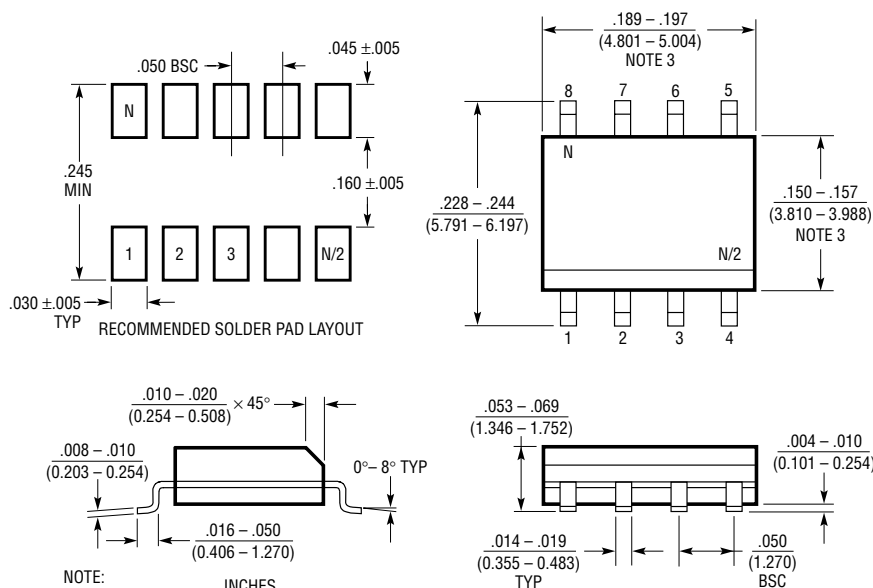

NOTE:
1. DIMENSIONS IN $\frac{\text{INCHES}}{\text{MILLIMETERS}}$
2. DRAWING NOT TO SCALE
3. THESE DIMENSIONS DO NOT INCLUDE MOLD FLASH OR PROTRUSIONS.
MOLD FLASH OR PROTRUSIONS SHALL NOT EXCEED .006" (0.15mm)

S08 0502

TYPICAL APPLICATIONS

Sample-and-Hold

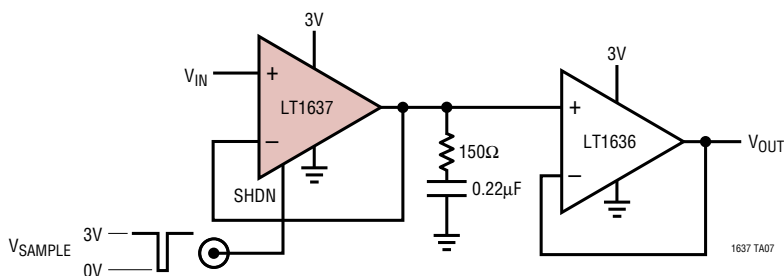

DROOP (LT1636 BUFFER): 200mV/s
 DROOP INTO HIGH IMPEDANCE : LESS THAN 0.625mV/s

MUX Amplifier

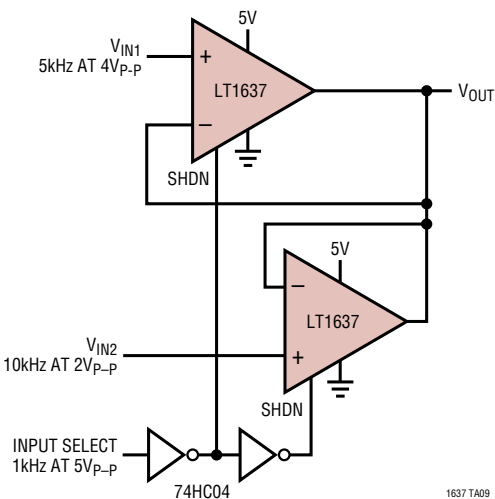

MUX Amplifier Waveforms

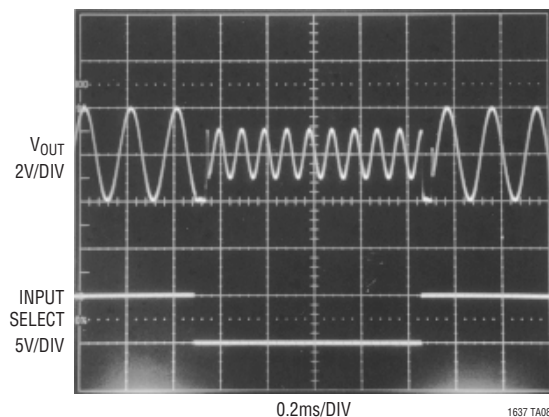

RELATED PARTS

PART NUMBER	DESCRIPTION	COMMENTS
LT1078/LT1079 LT2078/LT2079	Dual/Quad 55μA Max, Single Supply, Precision Op Amps	Input/Output Common Mode Includes Ground, 70μV $V_{OS(MAX)}$ and 2.5μV/°C Drift (Max), 200kHz GBW, 0.07V/μs Slew Rate
LT1178/LT1179 LT2178/LT2179	Dual/Quad 17μA Max, Single Supply, Precision Op Amps	Input/Output Common Mode Includes Ground, 70μV $V_{OS(MAX)}$ and 4μV/°C Drift (Max), 85kHz GBW, 0.04V/μs Slew Rate
LT1366/LT1367	Dual/Quad Precision, Rail-to-Rail Input and Output Op Amps	475μV $V_{OS(MAX)}$, 500V/mV $A_{VOL(MIN)}$, 400kHz GBW
LT1490/LT1491	Dual/Quad Over-The-Top Micropower, Rail-to-Rail Input and Output Op Amps	Single Supply Input Range: -0.4V to 44V, Micropower 50μA per Amplifier, Rail-to-Rail Input and Output, 200kHz GBW
LT1636	Single Over-The-Top Micropower Rail-to-Rail Input and Output Op Amp	55μA Supply Current, V_{CM} Extends 44V above V_{EE} , Independent of V_{CC} ; MSOP Package, Shutdown Function
LT1638/LT1639	Dual/Quad 1.2MHz Over-The-Top Micropower, Rail-to-Rail Input and Output Op Amps	0.4V/μs Slew Rate, 230μA Supply Current per Amplifier
LT1782	Micropower, Over-The-Top, SOT-23, Rail-to-Rail Input and Output Op Amp	SOT-23, 800μV $V_{OS(MAX)}$, $I_S = 55μA$ (Max), Gain-Bandwidth = 200kHz, Shutdown Pin
LT1783	1.2MHz, Over-The-Top, Micropower, Rail-to-Rail Input and Output Op Amp	SOT-23, 800μV $V_{OS(MAX)}$, $I_S = 300μA$ (Max), Gain-Bandwidth = 1.2MHz, Shutdown Pin

1637fb