

Compact Head-on PMT

Photosensor Modules H7827 Series

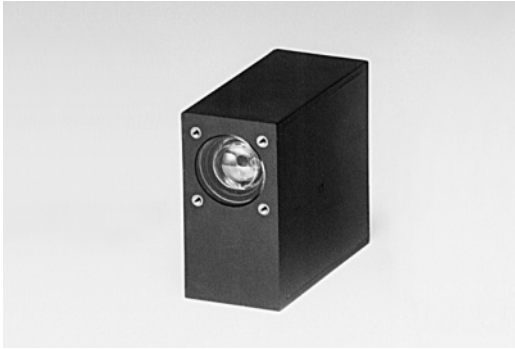

The H7827 series photosensor modules incorporate a 19-mm (3/4") diameter head-on photomultiplier tube, a high-voltage power supply circuit and a low noise amplifier. Two types of amplifiers are available with a current-to-voltage conversion factor of 1 V/μA or 0.1 V/μA and a frequency bandwidth of DC to 20 kHz or DC to 200 kHz. Two types of photomultiplier tubes with different spectral response characteristics are provided for measurement in the visible range or visible to near IR range.

Product Variations

Type No.	Spectral Response	Current-to-Voltage Conversion Factor	Frequency Bandwidth	Features
H7827-001	300 nm to 650 nm	1 V/μA	DC to 20 kHz	For general applications in visible range
H7827-011	300 nm to 850 nm			For visible to near IR range
H7827-002	300 nm to 650 nm	0.1 V/μA	DC to 200 kHz	For general applications in visible range
H7827-012	300 nm to 850 nm			For visible to near IR range

Specifications

Parameter		H7827 Series		Unit	
Suffix		-001 / -002	-011 / -012	—	
Input Voltage		±11.5 to ±15.5		V	
Max. Input Voltage		±18		V	
Max. Input Current		+40/-1		mA	
Max. Control Voltage		+1.2 (Input Impedance 100 kΩ)		V	
Recommended Control Voltage Adjustment Range		+0.5 to +1.1		V	
Effective Area		φ15		mm	
Sensitivity Adjustment Range		1: 10 ³		—	
Peak Sensitivity Wavelength		420	380	nm	
Cathode	Luminous Sensitivity	Min.	60	μA/lm	
		Typ.	90		
	Blue Sensitivity Index (CS 5-58)		10.5	—	
	Red/White Ratio		—	0.2	
Radiant Sensitivity *1		85	49	mA/W	
Suffix (with internal 20 kHz amp)		-001	-011		
Anode	Luminous Sensitivity *2	Min.	1.0 × 10 ⁷	V/lm	
		Typ.	5.0 × 10 ⁷		
	Radiant Sensitivity *1 *2		47	13	V/nW
	Voltage Output Depending on PMT Dark Current *2 *3	Typ.	3	3	mV
Max.		20	20		
Max. Output Signal Voltage		+10 (Load resistance 10 kΩ)		V	
Current-to-Voltage Conversion Factor		1		V/μA	
Suffix (with internal 200 kHz amp)		-002	-012		
Anode	Luminous Sensitivity *2	Min.	1.0 × 10 ⁶	V/lm	
		Typ.	5.0 × 10 ⁶		
	Radiant Sensitivity *1 *2		4.7	1.3	V/nW
	Voltage Output Depending on PMT Dark Current *2 *3	Typ.	0.3	0.3	mV
Max.		2	2		
Max. Output Signal Voltage		+10 (Load resistance 10 kΩ)		V	
Current-to-Voltage Conversion Factor		0.1		V/μA	
H7827 series					
Offset Voltage *2		Typ.		±3	mV
Ripple Noise *2 *4 (peak to peak)		Max.		4	mV
Settling Time *5				0.2	s
Operating Ambient Temperature				+5 to +45	°C
Storage Temperature				-20 to +50	°C
Weight				80	g

*1: Measured at the peak sensitivity wavelength *2: Control voltage = +1.0 V *3: After 30 minute storage in darkness

*4: Cable RG-174/U, Cable length 450 mm, Load resistance = 1 MΩ, Load capacitance = 22 pF

*5: The time required for the output to reach a stable level following a change in the control voltage from +1.0 V to +0.5 V.

Characteristics (Anode radiant sensitivity, PMT gain)

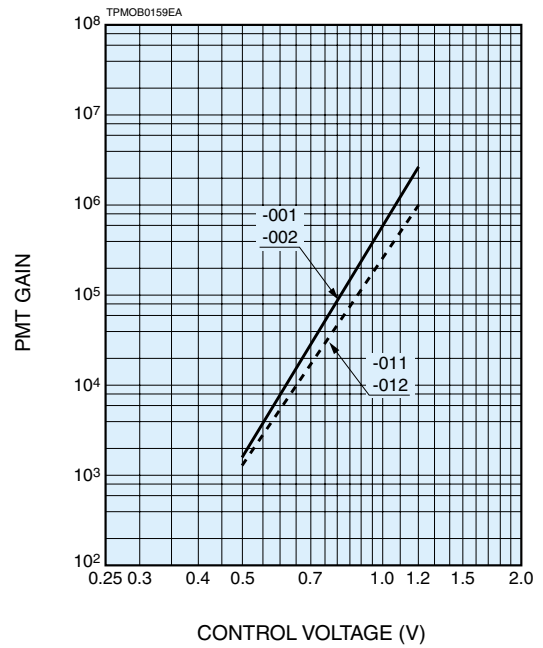
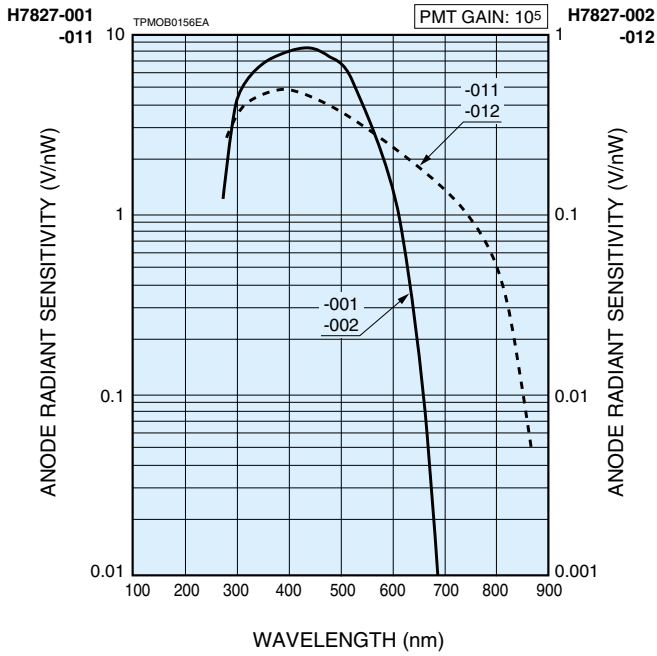

Sensitivity Adjustment Method

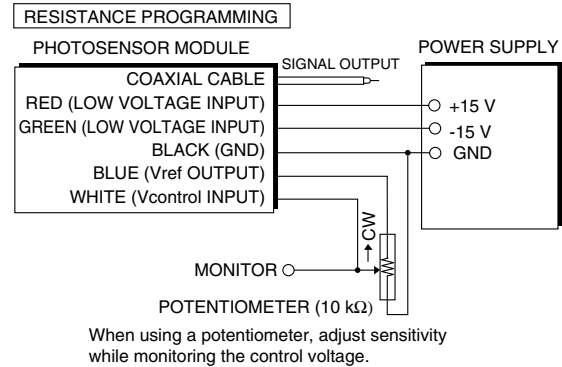
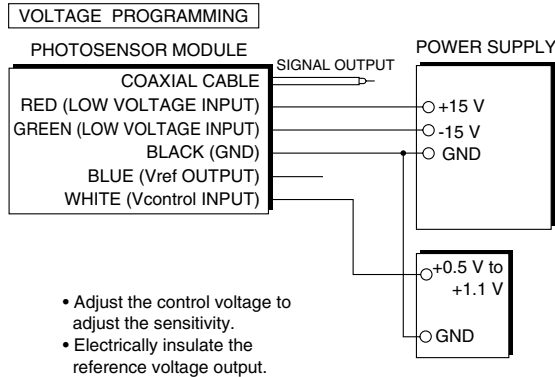

TPMOC0166EB

Dimensional Outlines (Unit: mm)

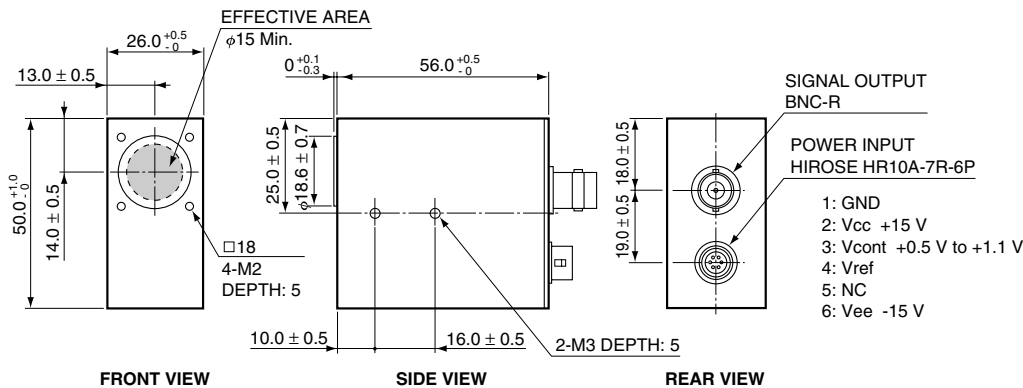

Power cable with connector (HIROSE HR10A-7P-6S) is supplied with the H7827 series

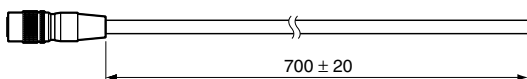

BLACK: GND
 RED: LOW VOLTAGE INPUT (+15 V)
 WHITE: Vcont INPUT (+0.5 V to +1.1 V)
 BLUE: Vref OUTPUT (+1.2 V)
 GREEN: LOW VOLTAGE INPUT (-15 V)

TPMOA0023EB