

MCW1000 Series

2W, Wide Input Range SIP, Single Output DC/DC Converters

Key Features

- High Efficiency up to 81%
- 1000VDC Isolation
- MTBF > 1,000,000 Hours
- 2:1 Wide Input Range
- Low Cost
- Remote On/Off Control
- Low Ripple and Noise
- Temperature Performance -40°C to $+85^{\circ}\text{C}$
- UL 94V-0 Package Material
- Internal SMD Construction

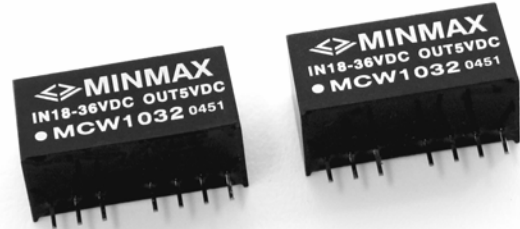

Minimax's MCW1000-Series power modules are low-profile dc-dc converters that operate over input voltage ranges of 4.5–9VDC, 9–18VDC, 18–36VDC and 36–75VDC which provide precisely regulated single output voltages of 3.3V, 5V and 12VDC.

The -40°C to $+85^{\circ}\text{C}$ operating temperature range makes it ideal for data communication equipments, mobile battery driven equipments, distributed power systems, telecommunication equipments, mixed analog/digital subsystems, process/machine control equipments, computer peripheral systems and industrial robot systems.

The modules have a maximum power rating of 2W and a typical full-load efficiency of 81%, continuous short circuit, 30mV output ripple, built-in filtering for both input and output minimize the need for external filtering.

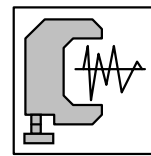

Low Noise

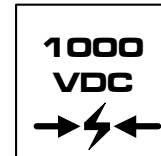

I/O Isolation

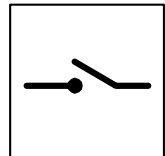

Remote on/off

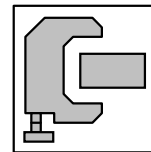

Low Profile

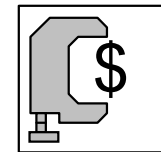

Low Cost

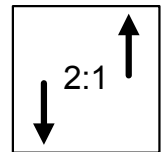

Wide Range

Block Diagram

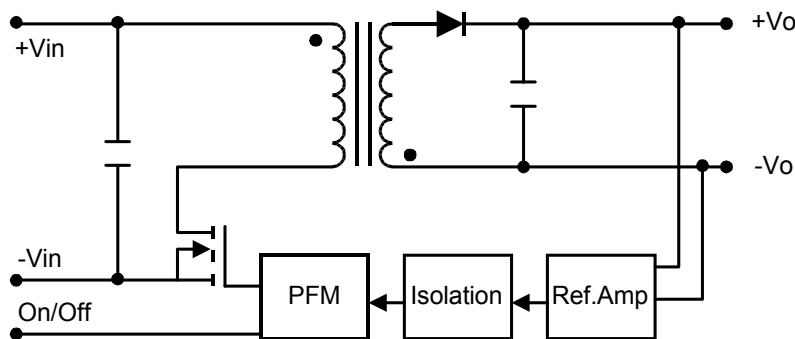

Model Selection Guide

Model Number	Input Voltage	Output Voltage	Output Current		Input Current		Reflected Ripple Current	Efficiency
			Max.	Min.	@Max. Load	@No Load		
	VDC	VDC	mA	mA	mA (Typ.)	mA (Typ.)	mA (Typ.)	% (Typ.)
MCW1011	5 (4.5 ~ 9)	3.3	500	125	471	40	400	70
MCW1012		5	400	100	548			73
MCW1013		12	167	42	534			75
MCW1021	12 (9 ~ 18)	3.3	500	125	184	20	300	73
MCW1022		5	400	100	217			77
MCW1023		12	167	42	209			80
MCW1031	24 (18 ~ 36)	3.3	500	125	96	10	200	72
MCW1032		5	400	100	109			77
MCW1033		12	167	42	103			81
MCW1041	48 (36 ~ 75)	3.3	500	125	49	8	500	71
MCW1042		5	400	100	57			73
MCW1043		12	167	42	53			79

Absolute Maximum Ratings

Parameter	Min.	Max.	Unit	
Input Surge Voltage (1000 mS)	5VDC Input Models	-0.7	15	VDC
	12VDC Input Models	-0.7	25	VDC
	24VDC Input Models	-0.7	50	VDC
	48VDC Input Models	-0.7	100	VDC
Lead Temperature (1.5mm from case for 10 Sec.)	---	260	°C	
Internal Power Dissipation	---	3500	mW	

Exceeding the absolute maximum ratings of the unit could cause damage.
These are not continuous operating ratings.

Environmental Specifications

Parameter	Conditions	Min.	Max.	Unit
Operating Temperature	Ambient	-40	+85	°C
Operating Temperature	Case	-40	+90	°C
Storage Temperature		-55	+105	°C
Humidity		---	95	%
Cooling	Free-Air Convection			

Notes :

- Specifications typical at Ta=+25°C, resistive load, nominal input voltage, rated output current unless otherwise noted.
- Transient recovery time is measured to within 1% error band for a step change in output load of 75% to 100%.
- Ripple & Noise measurement bandwidth is 0-20 MHz.
- These power converters require a minimum output loading to maintain specified regulation.
- Operation under no-load conditions will not damage these modules; however, they may not meet all specifications listed.
- All DC/DC converters should be externally fused at the front end for protection.
- Other input and output voltage may be available, please contact factory.
- Specifications subject to change without notice.

MCW1000 Series

Input Specifications

Parameter	Model	Min.	Typ.	Max.	Unit
Start Voltage	5V Input Models	3.5	4	4.5	VDC
	12V Input Models	4.5	7	9	
	24V Input Models	8	12	18	
	48V Input Models	16	24	36	
Under Voltage Shutdown	5V Input Models	---	3.5	4	
	12V Input Models	---	6.5	8.5	
	24V Input Models	---	11	17	
	48V Input Models	---	22	34	
Reverse Polarity Input Current	All Models	---	---	1	A
Short Circuit Input Power		---	---	1500	mW
Input Filter		Capacitor type			

Output Specifications

Parameter	Conditions	Min.	Typ.	Max.	Unit
Output Voltage Accuracy		---	±1	±2	%
Line Regulation	Vin=Min. to Max.	---	±0.3	±0.5	%
Load Regulation	Io=25% to 100%	---	±0.5	±0.75	%
Ripple & Noise (20MHz)		---	30	50	mV P-P
Ripple & Noise (20MHz)	Over Line, Load & Temp.	---	---	75	mV P-P
Ripple & Noise (20MHz)		---	---	15	mV rms
Over Power Protection		120	---	---	%
Transient Recovery Time	25% Load Step Change	---	100	300	µs
Transient Response Deviation		---	±3	±5	%
Temperature Coefficient		---	±0.01	±0.02	%/°C
Output Short Circuit	Continuous				

General Specifications

Parameter	Conditions	Min.	Typ.	Max.	Unit
Isolation Voltage Rated	60 Seconds	1000	---	---	VDC
Isolation Voltage Test	Flash Tested for 1 Second	1100	---	---	VDC
Isolation Resistance	500VDC	1000	---	---	MΩ
Isolation Capacitance	100KHz, 1V	---	65	120	pF
Switching Frequency		100	300	650	KHz
MTBF	MIL-HDBK-217F @ 25°C, Ground Benign	1000	---	---	K Hours

Remote On/Off Control

Parameter	Conditions	Min.	Typ.	Max.	Unit
Supply On	Under 0.6 VDC or Open Circuit, drops down to 0VDC by 2mV/°C				
Supply Off		2.7	---	15	VDC
Device Standby Input Current		---	0.1	0.2	mA
Control Input Current (on)	Vin-RC = 0V	---	---	-0.4	mA
Control Input Current (off)	Vin-RC = 5.0V	---	---	1	mA
Control Common	Referenced to Negative Input				

Capacitive Load

Models by Vout	3.3V	5V	12V	Unit
Maximum Capacitive Load	2200	1000	170	μF

Input Fuse Selection Guide

5V Input Models	12V Input Models	24V Input Models	48V Input Models
1500mA Slow – Blow Type	700mA Slow – Blow Type	350mA Slow – Blow Type	135mA Slow – Blow Type

Input Voltage Transient Rating

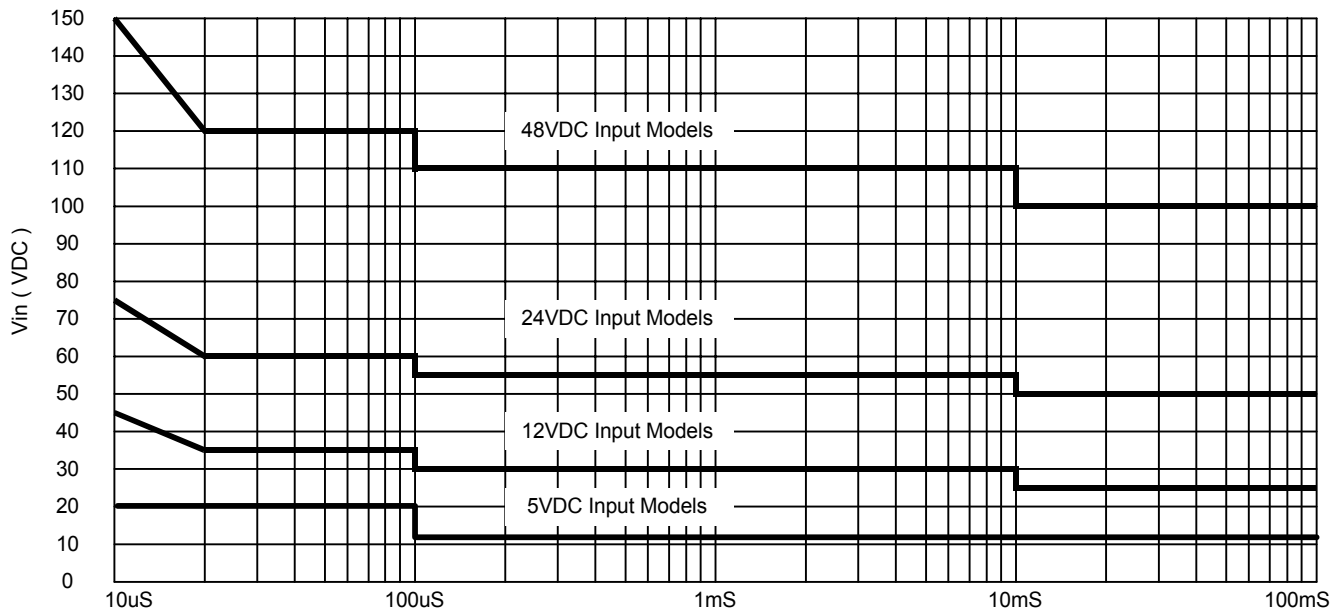

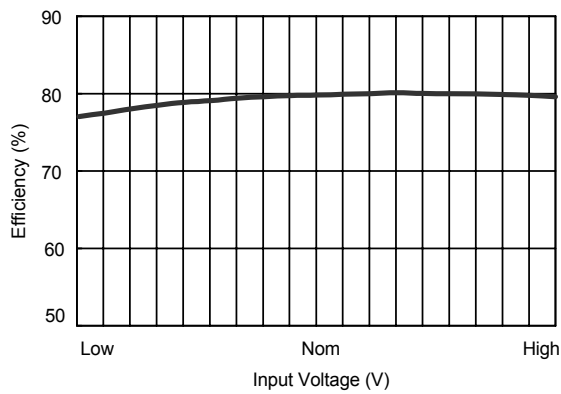

Efficiency vs Input Voltage

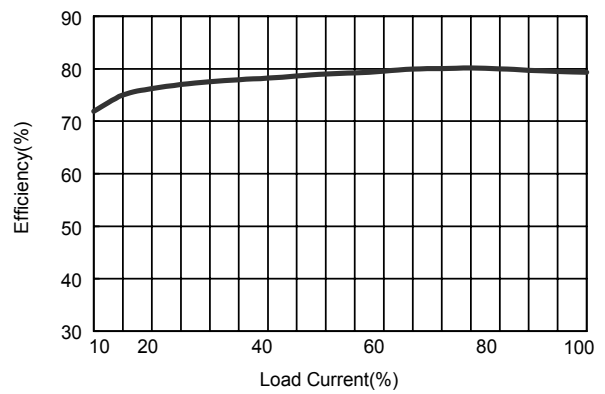

Efficiency vs Output Load

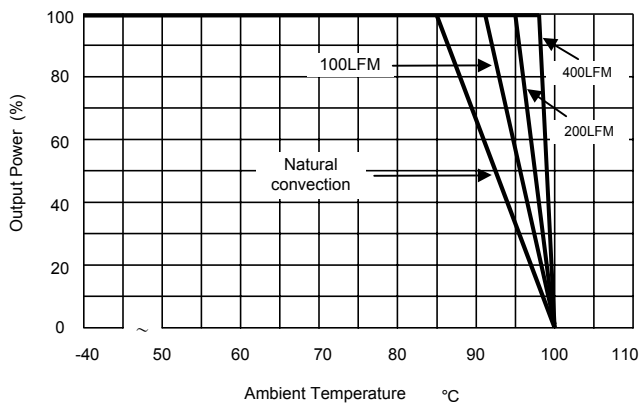

Derating Curve

Test Configurations

Input Reflected-Ripple Current Test Setup

Input reflected-ripple current is measured with an inductor L_{in} (4.7uH) and C_{in} (220uF, ESR < 1.0Ω at 100 KHz) to simulate source impedance.

Capacitor C_{in} , offsets possible battery impedance.

Current ripple is measured at the input terminals of the module, measurement bandwidth is 0–500 KHz.

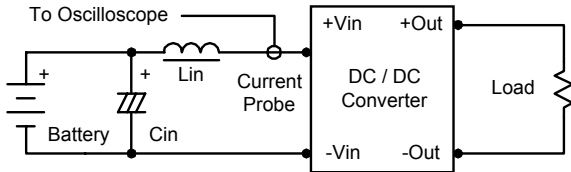

Peak-to-Peak Output Noise Measurement Test

Use a C_{out} 0.47uF ceramic capacitor.

Scope measurement should be made by using a BNC socket, measurement bandwidth is 0–20 MHz. Position the load between 50 mm and 75 mm from the DC/DC Converter.

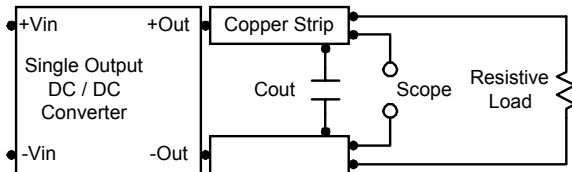

Design & Feature Considerations

Remote On/Off

Positive logic remote on/off turns the module on during a logic high voltage on the remote on/off pin, and off during a logic low.

To turn the power module on and off, the user must supply a switch to control the voltage between the on/off terminal and the –Vin terminal.

The switch can be an open collector or equivalent.

A logic low is 2.7V to 15V.

A logic high is under 0.6 VDC or open circuit, drops down to 0VDC by 2mV/°C

The maximum sink current at on/off terminal during a logic low is 1 mA.

The maximum allowable leakage current of the switch at on/off terminal (under 0.6VDC or open circuit) is –0.4mA.

Maximum Capacitive Load

The MCW1000 series has limitation of maximum connected capacitance at the output.

The power module may be operated in current limiting mode during start-up, affecting the ramp-up and the startup time.

The maximum capacitance can be found in the data sheet.

Overcurrent Protection

To provide protection in a fault (output overload) condition, the unit is equipped with internal current limiting circuitry and can endure current limiting for an unlimited duration. At the point of current-limit inception, the unit shifts from voltage control to current control. The unit operates normally once the output current is brought back into its specified range.

Input Source Impedance

The power module should be connected to a low ac-impedance input source. Highly inductive source impedances can affect the stability of the power module.

In applications where power is supplied over long lines and output loading is high, it may be necessary to use a capacitor at the input to ensure startup.

Capacitor mounted close to the power module helps ensure stability of the unit, it is recommended to use a good quality low Equivalent Series Resistance (ESR < 1.0Ω at 100 KHz) capacitor of a 8.2uF for the 5V input devices, a 3.3uF for the 12V input devices and a 1.5uF for the 24V and 48V devices.

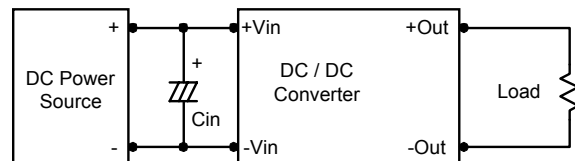

Output Ripple Reduction

A good quality low ESR capacitor placed as close as practicable across the load will give the best ripple and noise performance.

To reduce output ripple, it is recommended to use 3.3uF capacitors at the output.

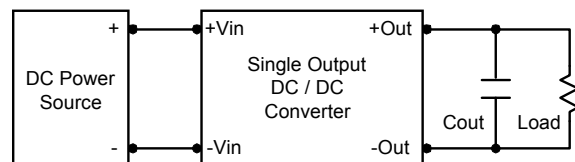

MCW1000 Series

Thermal Considerations

Many conditions affect the thermal performance of the power module, such as orientation, airflow over the module and board spacing. To avoid exceeding the maximum temperature rating of the components inside the power module, the case temperature must be kept below 90°C.

The derating curves are determined from measurements obtained in an experimental apparatus.

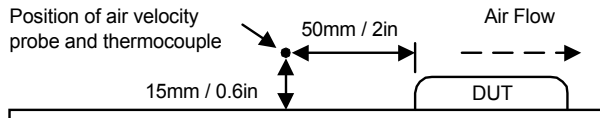

Mechanical Dimensions

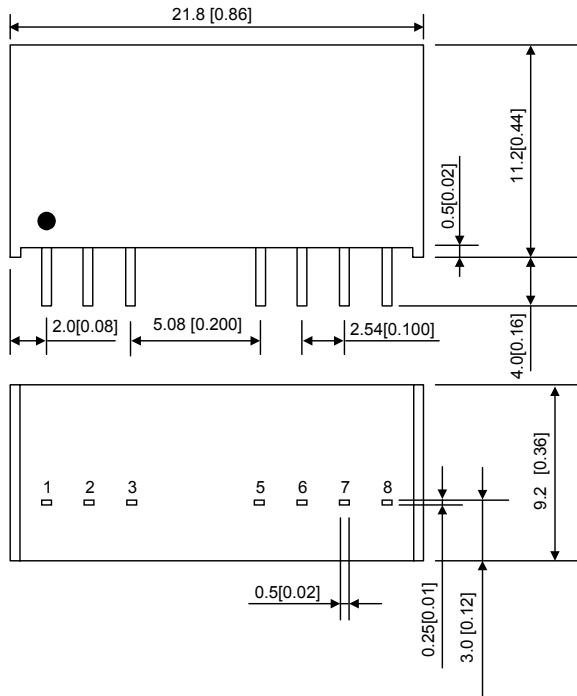

Connecting Pin Patterns

Top View (2.54 mm / 0.1 inch grids)

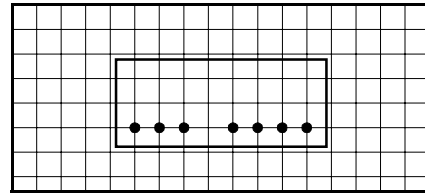

Tolerance	Millimeters	Inches
	$X.X \pm 0.25$	$X.XX \pm 0.01$
	$X.XX \pm 0.13$	$X.XXX \pm 0.005$
Pin	± 0.05	± 0.002

Pin Connections

Pin	Function
1	-Vin
2	+Vin
3	Remote On/Off
5	NC
6	+Vout
7	-Vout
8	NC

NC: No Connection

Physical Characteristics

Case Size	: 21.8x9.2x11.2mm 0.86x0.36x0.44inches
Case Material	: Non-Conductive Black Plastic
Weight	: 4.8g
Flammability	: UL94V-0

The MCW1000 converter is encapsulated in a low thermal resistance molding compound that has excellent resistance/electrical characteristics over a wide temperature range or in high humidity environments. The encapsulant and unit case are both rated to UL 94V-0 flammability specifications. Leads are tin plated for improved solderability.