

4M-BIT CMOS FAST SRAM

256K-WORD BY 16-BIT

EXTENDED TEMPERATURE OPERATION

Description

The μ PD444016L-Y is a high speed, low power, 4,194,304 bits (262,144 words by 16 bits) CMOS static RAM.

Operating supply voltage is $3.3\text{ V} \pm 0.3\text{ V}$.

The μ PD444016L-Y is packaged in 44-PIN PLASTIC TSOP (II).

Features

- 262,144 words by 16 bits organization
- Fast access time : 8, 10, 12 ns (MAX.)
- Byte data control : /LB (I/O1 - I/O8), /UB (I/O9 - I/O16)
- Output Enable input for easy application
- Single +3.3 V power supply

Ordering Information

Part number	Package	Access time ns (MAX.)	Supply current mA (MAX.)	
			At operating	At standby
μ PD444016LG5-A8Y-7JF	44-PIN PLASTIC TSOP (II) (10.16 mm (400))	8	210	5
μ PD444016LG5-A10Y-7JF		10	190	
μ PD444016LG5-A12Y-7JF	(Normal bent)	12	180	

The information in this document is subject to change without notice. Before using this document, please confirm that this is the latest version.
Not all devices/types available in every country. Please check with local NEC representative for availability and additional information.

Pin Configuration (Marking Side)

/xxx indicates active low signal.

44-PIN PLASTIC TSOP (II) (10.16 mm (400)) (Normal bent)
[μPD444016LG5-AxxY-7JF]

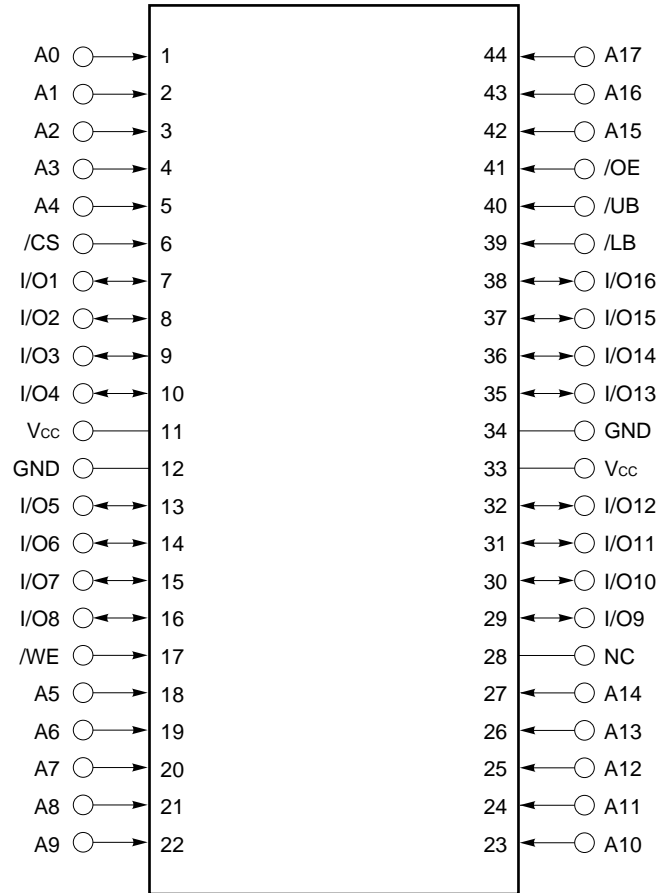

- A0 - A17 : Address Inputs
- I/O1 - I/O16 : Data Inputs / Outputs
- /CS : Chip Select
- /WE : Write Enable
- /OE : Output Enable
- /LB, /UB : Byte data select
- Vcc : Power supply
- GND : Ground
- NC : No connection

Remark Refer to **Package Drawing** for the 1-pin index mark.

Block Diagram

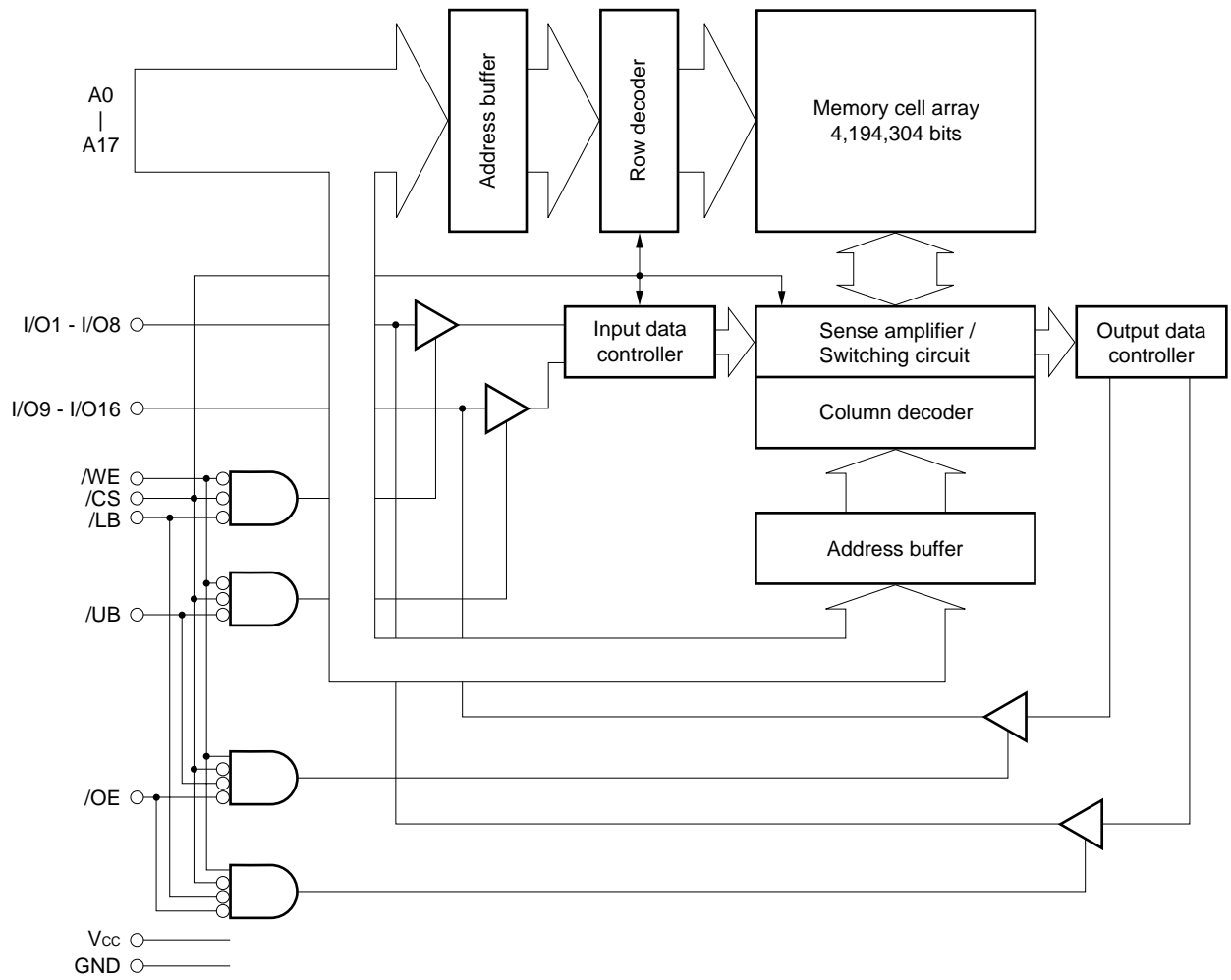

Truth Table

/CS	/OE	/WE	/LB	/UB	Mode	I/O		Supply current
						I/O1 - I/O8	I/O9 - I/O16	
H	x	x	x	x	Not selected	High impedance	High impedance	I _{SB}
L	L	H	L	L	Read	D _{OUT}	D _{OUT}	I _{CC}
			L	H		D _{OUT}	High impedance	
			H	L		High impedance	D _{OUT}	
L	x	L	L	L	Write	D _{IN}	D _{IN}	I _{CC}
			L	H		D _{IN}	High impedance	
			H	L		High impedance	D _{IN}	
L	H	H	x	x	Output disable	High impedance	High impedance	I _{CC}
			L	x		x	H	

Remark x : Don't care

Electrical Specifications

Absolute Maximum Ratings

Parameter	Symbol	Condition	Rating	Unit
Supply voltage	V _{CC}		-0.5 ^{Note} to +4.0	V
Input / Output voltage	V _T		-0.5 ^{Note} to +4.0	V
Operating ambient temperature	T _A		-40 to +85	°C
Storage temperature	T _{stg}		-55 to +125	°C

Note -2.0 V (MIN.) (pulse width : 2 ns)

Caution Exposing the device to stress above those listed in Absolute Maximum Rating could cause permanent damage. The device is not meant to be operated under conditions outside the limits described in the operational section of this specification. Exposure to Absolute Maximum Rating conditions for extended periods may affect device reliability.

Recommended Operating Conditions

Parameter	Symbol	Condition	MIN.	TYP.	MAX.	Unit
Supply voltage	V _{CC}		3.0	3.3	3.6	V
High level input voltage	V _{IH}		2.0		V _{CC} +0.3	V
Low level input voltage	V _{IL}		-0.3 ^{Note}		+0.8	V
Operating ambient temperature	T _A		-40		+85	°C

Note -2.0 V (MIN.) (pulse width : 2 ns)

DC Characteristics (Recommended Operating Conditions Unless Otherwise Noted)

Parameter	Symbol	Test condition	MIN.	TYP.	MAX.	Unit
Input leakage current	I _{LI}	V _{IN} = 0 V to V _{CC}	-2		+2	μA
Output leakage current	I _{LO}	V _{I/O} = 0 V to V _{CC} , /CS = V _{IH} or /OE = V _{IH} or /WE = V _{IL} or /LB = V _{IH} or /UB = V _{IH}	-2		+2	μA
Operating supply current	I _{CC}	/CS = V _{IL} , I _{I/O} = 0 mA,	Cycle time : 8 ns		210	mA
			Cycle time : 10 ns		190	
		Minimum cycle time	Cycle time : 12 ns		180	
Standby supply current	I _{SB}	/CS = V _{IH} , V _{IN} = V _{IH} or V _{IL}			40	mA
	I _{SB1}	/CS ≥ V _{CC} - 0.2 V, V _{IN} ≤ 0.2 V or V _{IN} ≥ V _{CC} - 0.2 V			5	
High level output voltage	V _{OH}	I _{OH} = -4.0 mA	2.4			V
Low level output voltage	V _{OL}	I _{OL} = +8.0 mA			0.4	V

Remarks 1. V_{IN} : Input voltage

V_{I/O} : Input / Output voltage

2. These DC characteristics are in common regardless of product classification.

Capacitance (T_A = 25 °C, f = 1 MHz)

Parameter	Symbol	Test condition	MIN.	TYP.	MAX.	Unit
Input capacitance	C _{IN}	V _{IN} = 0 V			6	pF
Input / Output capacitance	C _{I/O}	V _{I/O} = 0 V			8	pF

Remarks 1. V_{IN} : Input voltage

V_{I/O} : Input / Output voltage

2. These parameters are not 100% tested.

AC Characteristics (Recommended Operating Conditions Unless Otherwise Noted)

AC Test Conditions

Input Waveform (Rise and Fall Time ≤ 3 ns)

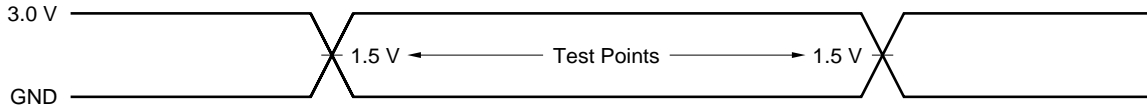

Output Waveform

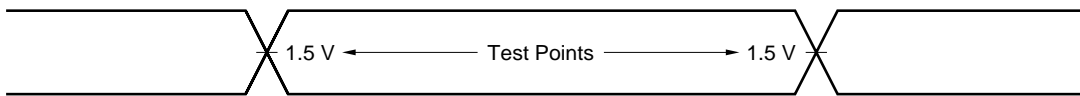

Output Load

AC characteristics directed with the note should be measured with the output load shown in **Figure 1** or **Figure 2**.

Figure 1

(t_{AA} , t_{ACS} , t_{OE} , t_{ABD} , t_{OH})

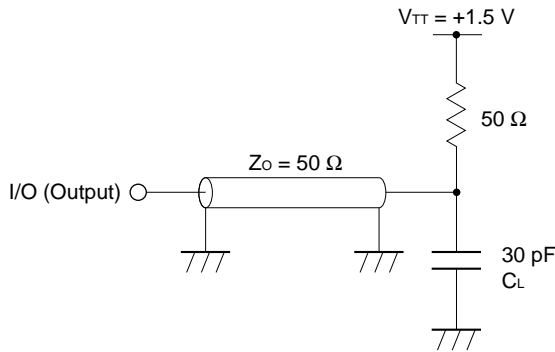
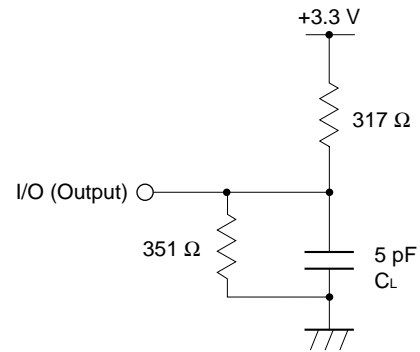

Figure 2

(t_{CLZ} , t_{OLZ} , t_{BLZ} , t_{CHZ} , t_{OHZ} , t_{BHZ} , t_{WHZ} , t_{OW})



Remark C_L includes capacitances of the probe and jig, and stray capacitances.

Read Cycle

Parameter	Symbol	μPD444016L-A8Y		μPD444016L-A10Y		μPD444016L-A12Y		Unit	Notes
		MIN.	MAX.	MIN.	MAX.	MIN.	MAX.		
Read cycle time	t _{RC}	8		10		12		ns	
Address access time	t _{AA}		8		10		12	ns	1
/CS access time	t _{ACS}		8		10		12	ns	
/OE access time	t _{OE}		4		5		6	ns	
/LB, /UB access time	t _{ABD}		4		5		6	ns	
Output hold from address change	t _{OH}	3		3		3		ns	
/CS to output in low impedance	t _{CLZ}	3		3		3		ns	2, 3
/OE to output in low impedance	t _{OLZ}	0		0		0		ns	
/LB, /UB to output in low impedance	t _{BLZ}	0		0		0		ns	
/CS to output in high impedance	t _{CHZ}		4		5		6	ns	
/OE to output hold in high impedance	t _{OHZ}		4		5		6	ns	
/LB, /UB to output hold in high impedance	t _{BHZ}		4		5		6	ns	

Notes 1. See the output load shown in Figure 1.

2. Transition is measured at ± 200 mV from steady-state voltage with the output load shown in Figure 2.
3. These parameters are not 100% tested.

Read Cycle Timing Chart 1 (Address Access)

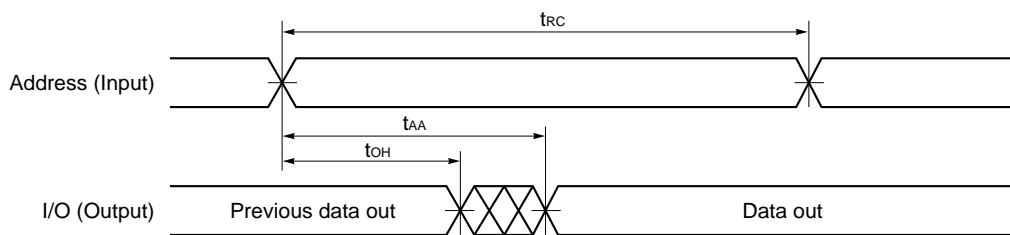

- Remarks 1. In read cycle, /WE should be fixed to high level.
2. /CS = /OE = /LB (or /UB) = V_{IL}

Read Cycle Timing Chart 2 (/CS Access)

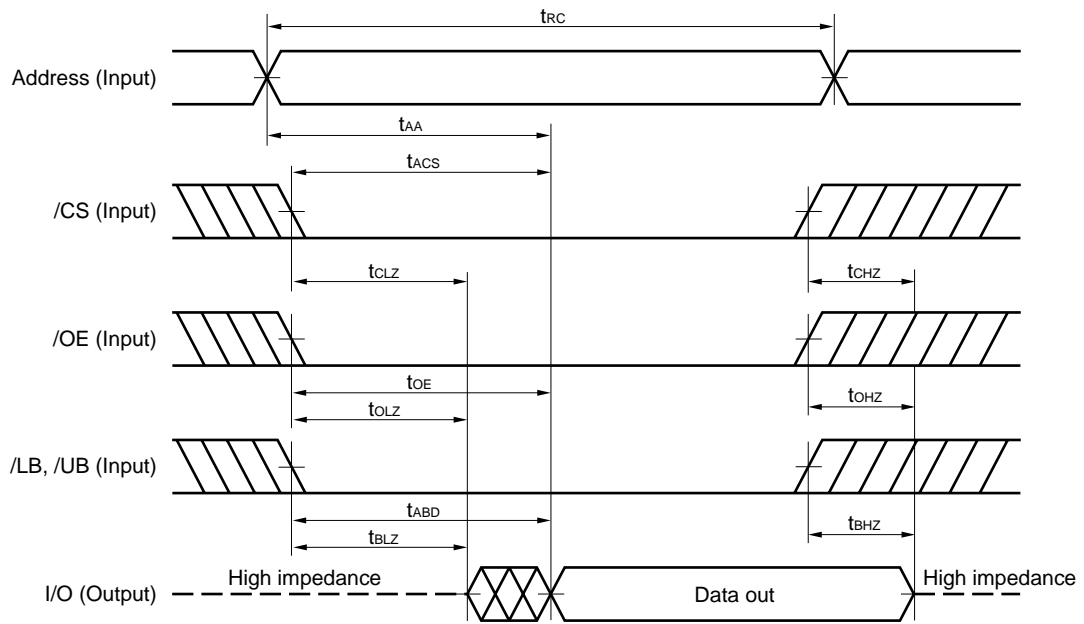

Caution Address valid prior to or coincident with /CS low level input.

Remark In read cycle, /WE should be fixed to high level.

Write Cycle

Parameter	Symbol	μPD444016L-A8Y		μPD444016L-A10Y		μPD444016L-A12Y		Unit	Notes
		MIN.	MAX.	MIN.	MAX.	MIN.	MAX.		
Write cycle time	t _{wc}	8		10		12		ns	
/CS to end of write	t _{cw}	6		7		8		ns	
Address valid to end of write	t _{aw}	6		7		8		ns	
Write pulse width	t _{wp}	6		7		8		ns	
/LB, /UB to end of write	t _{bw}	6		7		8		ns	
Data valid to end of write	t _{dW}	4		5		6		ns	
Data hold time	t _{dH}	0		0		0		ns	
Address setup time	t _{as}	0		0		0		ns	
Write recovery time	t _{wr}	0		0		0		ns	
/WE to output in high impedance	t _{whz}		4		5		6	ns	1, 2
Output active from end of write	t _{ow}	3		3		3		ns	

- Notes**
1. Transition is measured at ± 200 mV from steady-state voltage with the output load shown in **Figure 2**.
 2. These parameters are not 100% tested.

Write Cycle Timing Chart 1 (/WE Controlled)

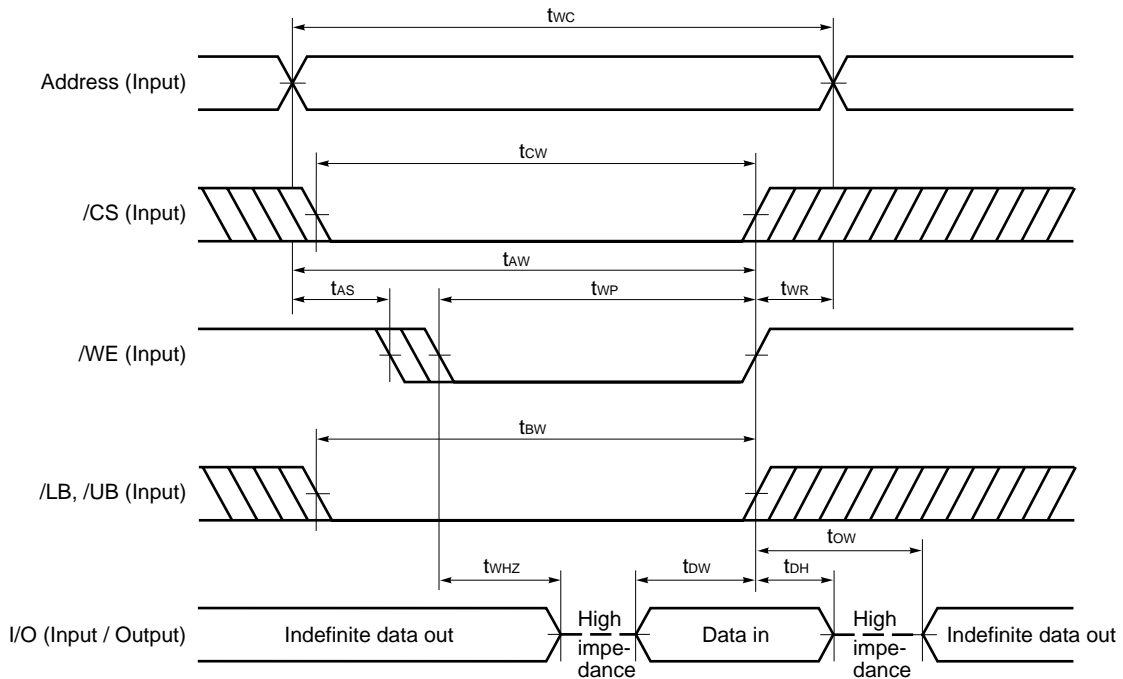

- Cautions**
1. /CS or /WE should be fixed to high level during address transition.
 2. Do not input data to the I/O pins while they are in the output state.

- Remarks**
1. Write operation is done during the overlap time of a low level /CS, /LB and/or /UB, and a low level /WE.
 2. When /WE is at low level, the I/O pins are always high impedance. When /WE is at high level, read operation is executed. Therefore /OE should be at high level to make the I/O pins high impedance.

Write Cycle Timing Chart 2 (/CS Controlled)

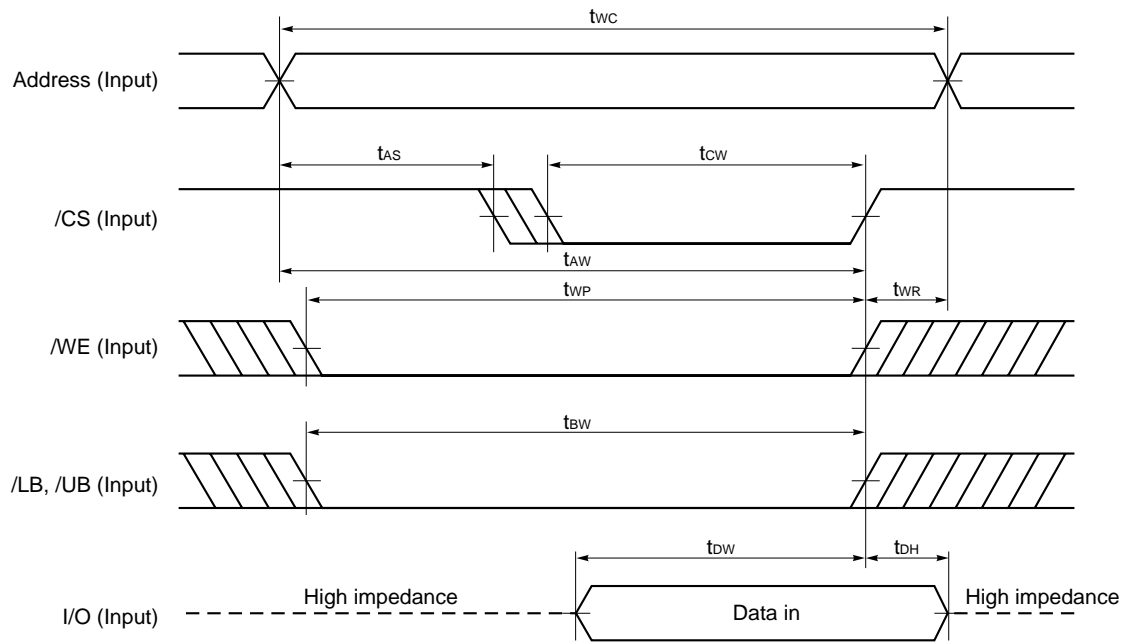

- Cautions**
1. /CS or /WE should be fixed to high level during address transition.
 2. Do not input data to the I/O pins while they are in the output state.

Remark Write operation is done during the overlap time of a low level /CS, /LB and/or /UB, and a low level /WE.

Write Cycle Timing Chart 3 (/LB, /UB Controlled)

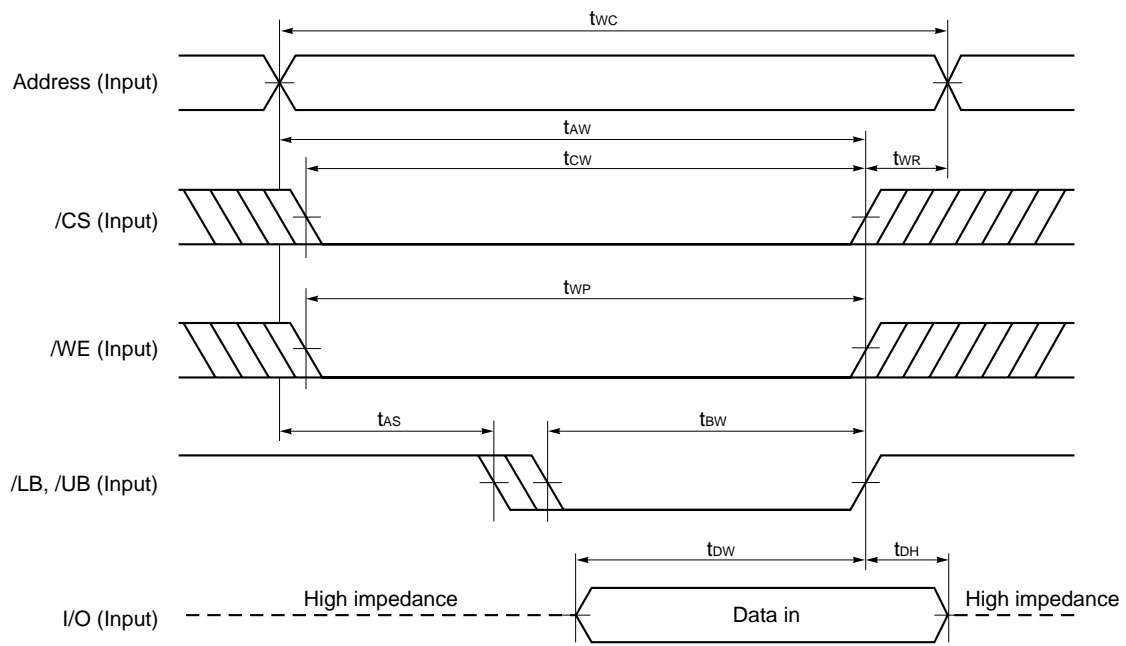

- Cautions**
1. /CS or /WE should be fixed to high level during address transition.
 2. Do not input data to the I/O pins while they are in the output state.

Remark Write operation is done during the overlap time of a low level /CS, /LB and/or /UB, and a low level /WE.

Package Drawing

44-PIN PLASTIC TSOP (II) (10.16 mm (400))

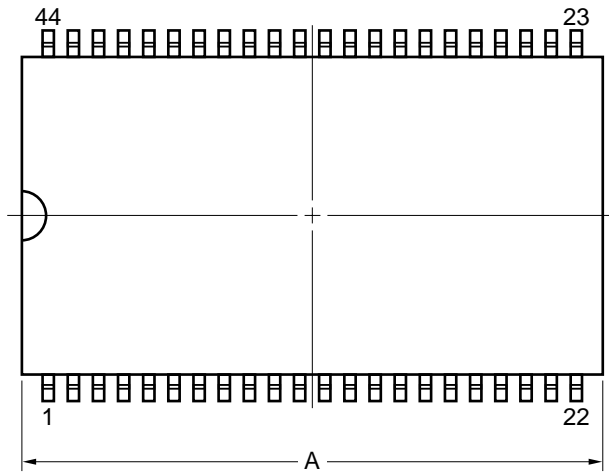

detail of lead end

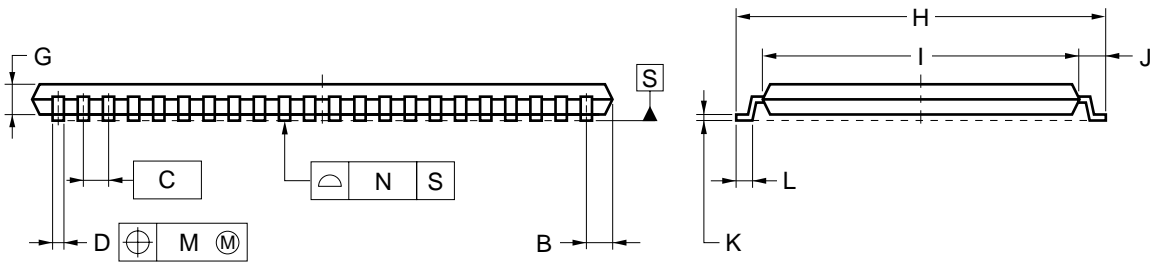
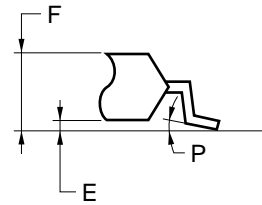

NOTE

Each lead centerline is located within 0.13 mm of its true position (T.P.) at maximum material condition.

ITEM	MILLIMETERS
A	18.63 MAX.
B	0.93 MAX.
C	0.8 (T.P.)
D	0.32 ^{+0.08} _{-0.07}
E	0.1±0.05
F	1.2 MAX.
G	0.97
H	11.76±0.2
I	10.16±0.1
J	0.8±0.2
K	0.145 ^{+0.025} _{-0.015}
L	0.5±0.1
M	0.13
N	0.10
P	3 ^{+7°} _{-3°}

S44G5-80-7JF5-1

Recommended Soldering Conditions

Please consult with our sales offices for soldering conditions of the μ PD444016L-Y.

Type of Surface Mount Device

μ PD444016LG5-7JF : 44-PIN PLASTIC TSOP (II) (10.16 mm (400)) (Normal bent)

[MEMO]

NOTES FOR CMOS DEVICES**① PRECAUTION AGAINST ESD FOR SEMICONDUCTORS**

Note:

Strong electric field, when exposed to a MOS device, can cause destruction of the gate oxide and ultimately degrade the device operation. Steps must be taken to stop generation of static electricity as much as possible, and quickly dissipate it once, when it has occurred. Environmental control must be adequate. When it is dry, humidifier should be used. It is recommended to avoid using insulators that easily build static electricity. Semiconductor devices must be stored and transported in an anti-static container, static shielding bag or conductive material. All test and measurement tools including work bench and floor should be grounded. The operator should be grounded using wrist strap. Semiconductor devices must not be touched with bare hands. Similar precautions need to be taken for PW boards with semiconductor devices on it.

② HANDLING OF UNUSED INPUT PINS FOR CMOS

Note:

No connection for CMOS device inputs can be cause of malfunction. If no connection is provided to the input pins, it is possible that an internal input level may be generated due to noise, etc., hence causing malfunction. CMOS devices behave differently than Bipolar or NMOS devices. Input levels of CMOS devices must be fixed high or low by using a pull-up or pull-down circuitry. Each unused pin should be connected to V_{DD} or GND with a resistor, if it is considered to have a possibility of being an output pin. All handling related to the unused pins must be judged device by device and related specifications governing the devices.

③ STATUS BEFORE INITIALIZATION OF MOS DEVICES

Note:

Power-on does not necessarily define initial status of MOS device. Production process of MOS does not define the initial operation status of the device. Immediately after the power source is turned ON, the devices with reset function have not yet been initialized. Hence, power-on does not guarantee out-pin levels, I/O settings or contents of registers. Device is not initialized until the reset signal is received. Reset operation must be executed immediately after power-on for devices having reset function.

- **The information in this document is current as of February, 2001. The information is subject to change without notice. For actual design-in, refer to the latest publications of NEC's data sheets or data books, etc., for the most up-to-date specifications of NEC semiconductor products. Not all products and/or types are available in every country. Please check with an NEC sales representative for availability and additional information.**
 - No part of this document may be copied or reproduced in any form or by any means without prior written consent of NEC. NEC assumes no responsibility for any errors that may appear in this document.
 - NEC does not assume any liability for infringement of patents, copyrights or other intellectual property rights of third parties by or arising from the use of NEC semiconductor products listed in this document or any other liability arising from the use of such products. No license, express, implied or otherwise, is granted under any patents, copyrights or other intellectual property rights of NEC or others.
 - Descriptions of circuits, software and other related information in this document are provided for illustrative purposes in semiconductor product operation and application examples. The incorporation of these circuits, software and information in the design of customer's equipment shall be done under the full responsibility of customer. NEC assumes no responsibility for any losses incurred by customers or third parties arising from the use of these circuits, software and information.
 - While NEC endeavours to enhance the quality, reliability and safety of NEC semiconductor products, customers agree and acknowledge that the possibility of defects thereof cannot be eliminated entirely. To minimize risks of damage to property or injury (including death) to persons arising from defects in NEC semiconductor products, customers must incorporate sufficient safety measures in their design, such as redundancy, fire-containment, and anti-failure features.
 - NEC semiconductor products are classified into the following three quality grades:
"Standard", "Special" and "Specific". The "Specific" quality grade applies only to semiconductor products developed based on a customer-designated "quality assurance program" for a specific application. The recommended applications of a semiconductor product depend on its quality grade, as indicated below. Customers must check the quality grade of each semiconductor product before using it in a particular application.
"Standard": Computers, office equipment, communications equipment, test and measurement equipment, audio and visual equipment, home electronic appliances, machine tools, personal electronic equipment and industrial robots
"Special": Transportation equipment (automobiles, trains, ships, etc.), traffic control systems, anti-disaster systems, anti-crime systems, safety equipment and medical equipment (not specifically designed for life support)
"Specific": Aircraft, aerospace equipment, submersible repeaters, nuclear reactor control systems, life support systems and medical equipment for life support, etc.
- The quality grade of NEC semiconductor products is "Standard" unless otherwise expressly specified in NEC's data sheets or data books, etc. If customers wish to use NEC semiconductor products in applications not intended by NEC, they must contact an NEC sales representative in advance to determine NEC's willingness to support a given application.
- (Note)
- (1) "NEC" as used in this statement means NEC Corporation and also includes its majority-owned subsidiaries.
 - (2) "NEC semiconductor products" means any semiconductor product developed or manufactured by or for NEC (as defined above).