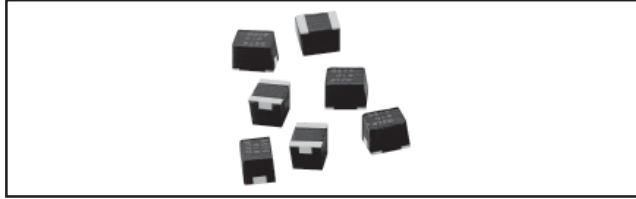

Inductors

Surface Mount, Molded, Shielded

FEATURES

- Molded construction provides superior strength and moisture resistance.
- Tape and reel packaging for automatic handling, 2000/reel, EIA 481.
- Compatible with vapor phase, infrared and wave soldering methods.
- Shielded construction minimizes coupling to other components.

STANDARD ELECTRICAL SPECIFICATIONS

IND. (μ H)	TOL.	Q MIN.	TEST FREQ. L & Q (MHz)	SELF- RESONANT FREQ. MIN. (MHz)	DCR MAX. (Ohms)	RATED DC CURRENT (mA)
0.010	$\pm 20\%$	50	50	1000	0.10	810
0.012	$\pm 20\%$	50	50	1000	0.11	750
0.015	$\pm 20\%$	50	50	1000	0.12	720
0.018	$\pm 20\%$	50	50	1000	0.13	690
0.022	$\pm 20\%$	45	50	1000	0.15	640
0.027	$\pm 20\%$	45	50	1000	0.17	610
0.033	$\pm 20\%$	45	50	1000	0.18	585
0.039	$\pm 20\%$	40	50	1000	0.24	530
0.047	$\pm 20\%$	40	50	1000	0.26	495
0.056	$\pm 20\%$	40	50	1000	0.28	485
0.068	$\pm 20\%$	40	50	1000	0.35	475
0.082	$\pm 20\%$	38	50	900	0.45	460
0.10	$\pm 20\%$	36	50	700	0.50	450
0.12	$\pm 20\%$	40	25.2	500	0.20	630
0.15	$\pm 20\%$	40	25.2	470	0.20	600
0.18	$\pm 20\%$	40	25.2	400	0.24	580
0.22	$\pm 20\%$	40	25.2	330	0.30	565
0.27	$\pm 20\%$	40	25.2	310	0.33	500
0.33	$\pm 20\%$	40	25.2	280	0.36	475
0.39	$\pm 20\%$	40	25.2	230	0.40	465
0.47	$\pm 20\%$	40	25.2	220	0.44	460
0.56	$\pm 20\%$	40	25.2	200	0.46	455
0.68	$\pm 20\%$	40	25.2	180	0.48	450
0.82	$\pm 20\%$	40	25.2	160	0.50	450
1.0	$\pm 10\%$	30	7.96	120	0.60	400
1.2	$\pm 10\%$	30	7.96	110	0.65	390
1.5	$\pm 10\%$	30	7.96	90.0	0.75	370
1.8	$\pm 10\%$	30	7.96	85.0	0.85	350
2.2	$\pm 10\%$	30	7.96	65.0	0.90	320
2.7	$\pm 10\%$	30	7.96	60.0	1.00	290
3.3	$\pm 10\%$	30	7.96	60.0	1.10	270
3.9	$\pm 10\%$	30	7.96	58.0	1.20	250
4.7	$\pm 10\%$	30	7.96	52.0	1.25	220
5.6	$\pm 10\%$	30	7.96	50.0	1.40	210
6.8	$\pm 10\%$	30	7.96	40.0	1.60	205
8.2	$\pm 10\%$	30	7.96	35.0	1.65	195
10.0	$\pm 10\%$	30	2.52	30.0	2.00	185
12.0	$\pm 10\%$	30	2.52	24.0	2.30	175
15.0	$\pm 10\%$	30	2.52	20.0	2.50	165
18.0	$\pm 10\%$	30	2.52	17.0	2.70	155
22.0	$\pm 10\%$	30	2.52	16.0	3.10	150
27.0	$\pm 10\%$	30	2.52	14.5	3.30	125
33.0	$\pm 10\%$	30	2.52	14.5	5.10	115
39.0	$\pm 10\%$	30	2.52	14.0	5.90	105
47.0	$\pm 10\%$	30	2.52	13.0	8.00	100
56.0	$\pm 10\%$	30	2.52	11.5	10.0	95
68.0	$\pm 10\%$	30	2.52	11.0	10.0	90
82.0	$\pm 10\%$	30	2.52	11.0	11.0	85
100.0	$\pm 10\%$	30	0.796	6.0	12.0	80

ELECTRICAL SPECIFICATIONS

Inductance Range: .01 μ H to 100 μ H.

Inductance Tolerance: $\pm 20\%$ for .01 μ H to .82 μ H.

 $\pm 10\%$ for 1.0 μ H to 100 μ H standard. 2%, 3% and 5% (also 1% on some values) tolerances available.

Temperature Range: -55°C to +125°C.

Coilform Material: Non-magnetic for .01 μ H to .10 μ H.

 Powdered Iron for .12 μ H to 100 μ H.

TEST EQUIPMENT

- H/P 4342A Q meter with Vishay Dale test fixture or equivalent.
- H/P 4191A RF Impedance Analyzer (for SRF measurements).
- Wheatstone Bridge.

DIMENSIONAL CONFIGURATIONS

[Numbers in brackets indicate millimeters]

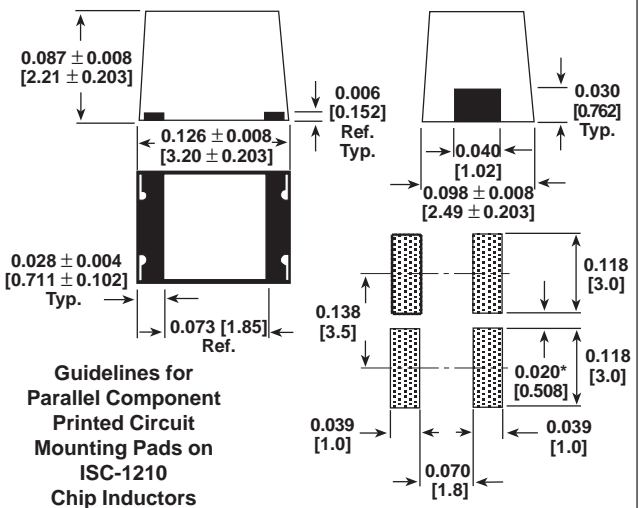

*Recommended minimum spacing between components.

PART MARKING

- Dale
- Inductance value
- Date code

HOW TO ORDER

ISC-1210	10 μ H	$\pm 10\%$
MODEL	INDUCTANCE VALUE	INDUCTANCE TOLERANCE