

SN74BCT2414
MEMORY DECODER
WITH ON-CHIP SUPPLY VOLTAGE MONITOR

SCBS059B – MARCH 1989 – REVISED NOVEMBER 1993

logic symbol†

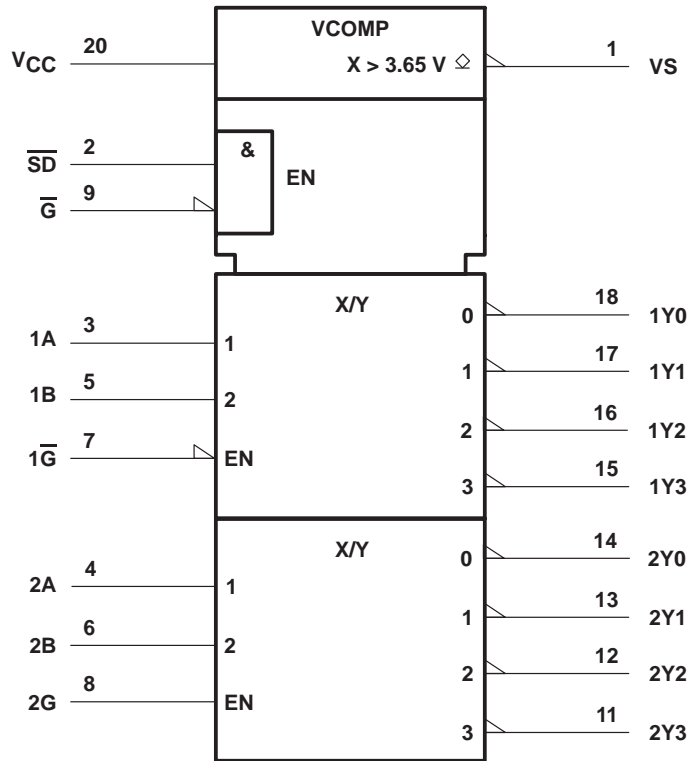

† This symbol is in accordance with ANSI/IEEE Std 91-1984 and IEC Publication 617-12.

logic diagram (positive logic)

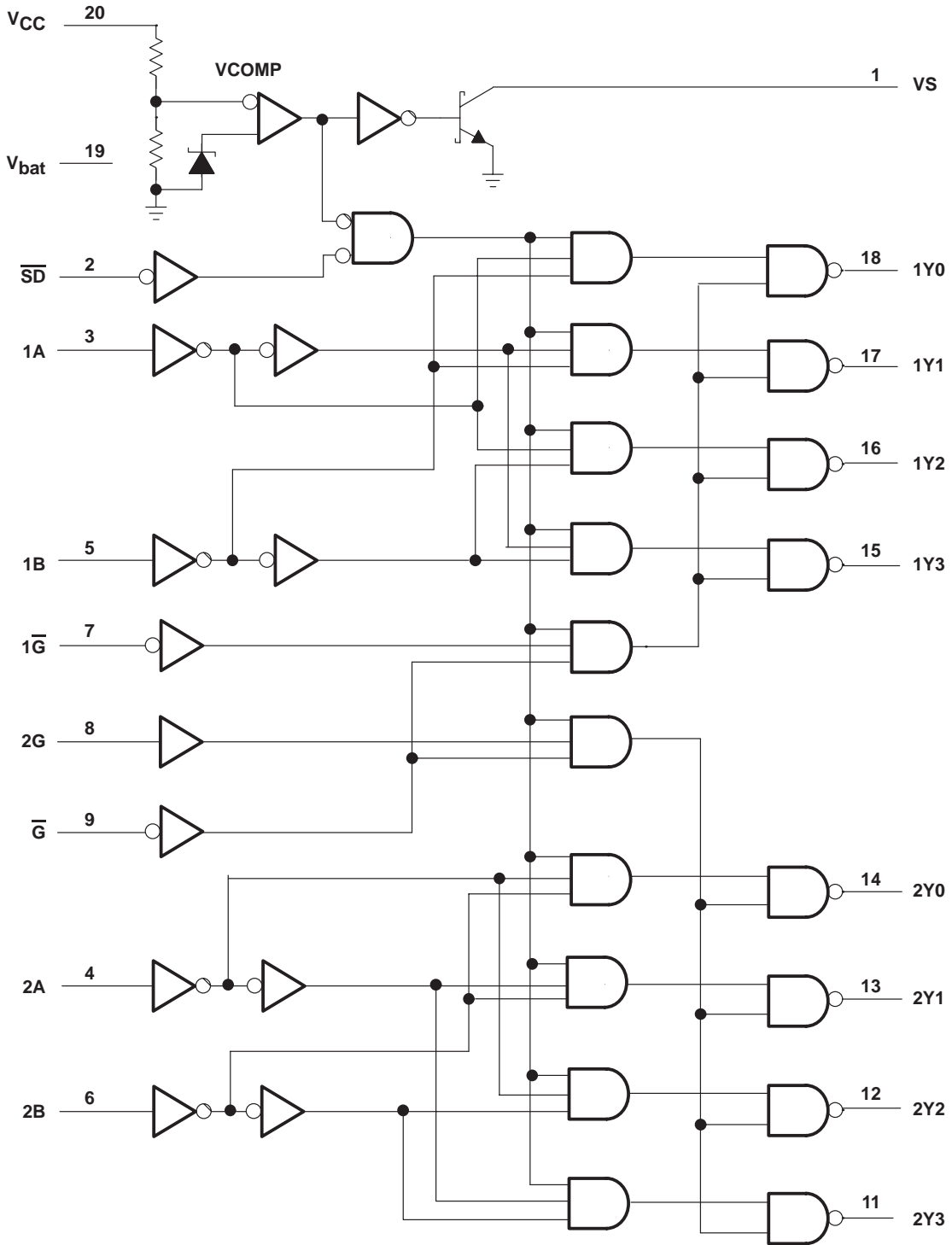

SN74BCT2414
MEMORY DECODER
WITH ON-CHIP SUPPLY VOLTAGE MONITOR

SCBS059B – MARCH 1989 – REVISED NOVEMBER 1993

FUNCTION TABLES

INPUTS					OUTPUTS			
CONTROL			SELECT					
\overline{G}	$1\overline{G}$	\overline{SD}	1B	1A	1Y0	1Y1	1Y2	1Y3
H	X	X	X	X	H	H	H	H
X	H	X	X	X	H	H	H	H
X	X	L	X	X	H	H	H	H
L	L	H	L	L	L	H	H	H
L	L	H	L	H	H	L	H	H
L	L	H	H	L	H	H	L	H
L	L	H	H	H	H	H	H	L

INPUTS					OUTPUTS			
CONTROL			SELECT					
\overline{G}	2G	\overline{SD}	2B	2A	2Y0	2Y1	2Y2	2Y3
H	X	X	X	X	H	H	H	H
X	H	X	X	X	H	H	H	H
X	X	L	X	X	H	H	H	H
L	H	H	L	L	L	H	H	H
L	H	H	L	H	H	L	H	H
L	H	H	H	L	H	H	L	H
L	H	H	H	H	H	H	H	L

NOTE: For a 3-line to 8-line decoder, the following pins must be shorted: $1\overline{G}$ to 2G, 1A to 2A and 1B to 2B.

absolute maximum ratings over operating free-air temperature range (unless otherwise noted)†

Supply voltage range, V_{bat}	-0.5 V to 7 V
Supply voltage range, V_{CC}	-0.5 V to 7 V
Supply voltage V_{CC} with respect to V_{bat}	-1.5 V
Input voltage range, V_I	-0.5 V to $V_{CC} + 0.5$ V
Off-state output voltage range at V_S	-0.5 V to 7 V
Voltage range applied to any Y output in the power-off state	-0.5 V to 7 V
Voltage applied to any Y output in the power-off state with respect to V_{bat}	0.5 V
Operating free-air temperature range	0°C to 70°C
Storage temperature range	-65°C to 150°C

† Stresses beyond those listed under "absolute maximum ratings" may cause permanent damage to the device. These are stress ratings only, and functional operation of the device at these or any other conditions beyond those indicated under "recommended operating conditions" is not implied. Exposure to absolute-maximum-rated conditions for extended periods may affect device reliability



recommended operating conditions

		MIN	NOM	MAX	UNIT
V _{CC}	Supply voltage	4.5	5	5.5	V
V _{bat}	Supply voltage	4.5	5	5.5	V
V _{IH}	High-level input voltage	2			V
V _{IL}	Low-level input voltage			0.8	V
I _{IK}	Input clamp current			-18	mA
I _{OH}	High-level output current			-400	μA
I _{OL}	Low-level output current	Y outputs		8	mA
		VS outputs		20	
t _t	Input transition time	0		10	ns/V
T _A	Operating free-air temperature	0		70	°C

electrical characteristics over recommended operating free-air temperature range (unless otherwise noted)

PARAMETER		TEST CONDITIONS		MIN	TYP†	MAX	UNIT
V _{IK}		V _{CC} = 4.5 V,	I _I = -18 mA			-1.2	V
V _{OH}		V _{bat} = V _{CC} = 4.5 V	I _{OH} = -20 μA	4.4			V
			I _{OH} = -400 μA	3.5			
		V _{bat} = 2 V, V _{CC} = 0,	I _{OH} = -50 μA	1.8			
V _{OL}	All except VS	V _{bat} = V _{CC} = 4.5 V	I _{OL} = 4 mA			0.4	V
			I _{OL} = 8 mA			0.5	
	VS	V _{bat} = V _{CC} = 4.5 V,	I _{OL} = 20 mA			1	
V _{T‡}					3.65		V
I _I		V _{bat} = V _{CC} = 5.5 V,	V _I = 5.5 V			100	μA
I _{IH}		V _{bat} = V _{CC} = 5.5 V,	V _I = 2.7 V			±20	μA
I _{IL}		V _{bat} = V _{CC} = 5.5 V,	V _I = 0.5 V			±20	μA
I _{OH}	VS	V _{bat} = 4.5 V,	V _{CC} = 0			1	μA
I _{O§}		V _{bat} = V _{CC} = 5.5 V,	V _O = 2.25 V	-30		-200	mA
I _{CC}		V _{bat} = V _{CC} = 5.5 V	Outputs high			3	mA
			Outputs low			3	
I _{bat}		V _{bat} = 2.5 V,	V _{CC} = 0		1	10	μA
			Outputs high			20	
		V _{bat} = V _{CC} = 5.5 V	Outputs low			3	mA
C _i		V _{bat} = V _{CC} = 5 V,	V _I = 0 or 3 V		4		pF
C _o	Any Y				6.5		pF
	VS	V _{bat} = V _{CC} = 0			5		

† All typical values are at V_{CC} = 5 V, T_A = 25°C.

‡ This value represents the V_{CC} monitor threshold voltage. Typical range is from 3.5 V to 3.8 V.

§ This output condition has been chosen to produce a current that closely approximates one half of the short-circuit output current, I_{O§}. Not more than one output should be tested at a time, and the duration of the test should not exceed one second.

SN74BCT2414
MEMORY DECODER
WITH ON-CHIP SUPPLY VOLTAGE MONITOR

SCBS059B – MARCH 1989 – REVISED NOVEMBER 1993

switching characteristics (see Note 1)

PARAMETER	FROM (INPUT)	TO (OUTPUT)	V _{CC} = 5 V, C _L = 50 pF, R1 = 500 Ω, R2 = 500 Ω, T _A = 25°C			V _{CC} = 4.5 V to 5.5 V, C _L = 50 pF, R1 = 500 Ω, R2 = 500 Ω, T _A = MIN to MAX†		UNIT
			MIN	TYP	MAX	MIN	MAX	
t _{PLH}	A or B	Any Y	1	5	10	1	12	ns
t _{PHL}			2	5.8	10	2	12	
t _{PLH}	Any \bar{G}	Any Y	1	4.5	9	1	10	ns
t _{PHL}			2	5.5	9	2	11	
t _{PLH}	\bar{SD}	Any Y	2	6.5	11	2	12	ns
t _{PHL}			2	6.5	11	2	12	

switching characteristics (see Note 1)

PARAMETER	FROM (INPUT)	TO (OUTPUT)	V _{CC} = 5 V, C _L = 50 pF, R1 = 500 Ω, R2 = 500 Ω, T _A = 25°C			V _{CC} = 4.5 V to 5.5 V, C _L = 50 pF, R1 = 500 Ω, R2 = 500 Ω, T _A = MIN to MAX†		UNIT
			MIN	TYP	MAX	MIN	MAX	
t _{PLH}	V _{CC}	Any Y	10	25	50	10	250	ns
t _{PHL}			15	45	100	15	250	
t _{PLH}	V _{CC}	VS	10	28	50	10	250	ns
t _{PHL}			20	50	100	20	250	

† For conditions shown as MIN or MAX, use the appropriate value specified under recommended operating conditions.

NOTE 1: Load circuits and voltage waveforms are shown in Section 1.

APPLICATION INFORMATION

A typical application circuit for a battery-buffered memory in a microcomputer system is shown in Figure 1 which uses the SN74BCT2414. When power fails, the supply-voltage supervisor (TL7705) resets the microcomputer and disables the memory by switching the shutdown input \overline{SD} of the memory decoder to a logic zero. All memory decoder outputs are forced to a logic one. Abnormal write commands from the microprocessor, which may be issued during further voltage breakdown, no longer affect the contents of the memory. When the system supply voltage becomes lower than approximately 3.65 V, the voltage monitor inside the SN74BCT2414 memory decoder disconnects the input buffers of this circuit from the decoding logic internally and keeps all outputs at a logic one. The VS output is also switched off, disconnecting the system supply voltage from the memory circuits. During this low-voltage condition, the memory decoder and the memory circuits are supplied by the battery.

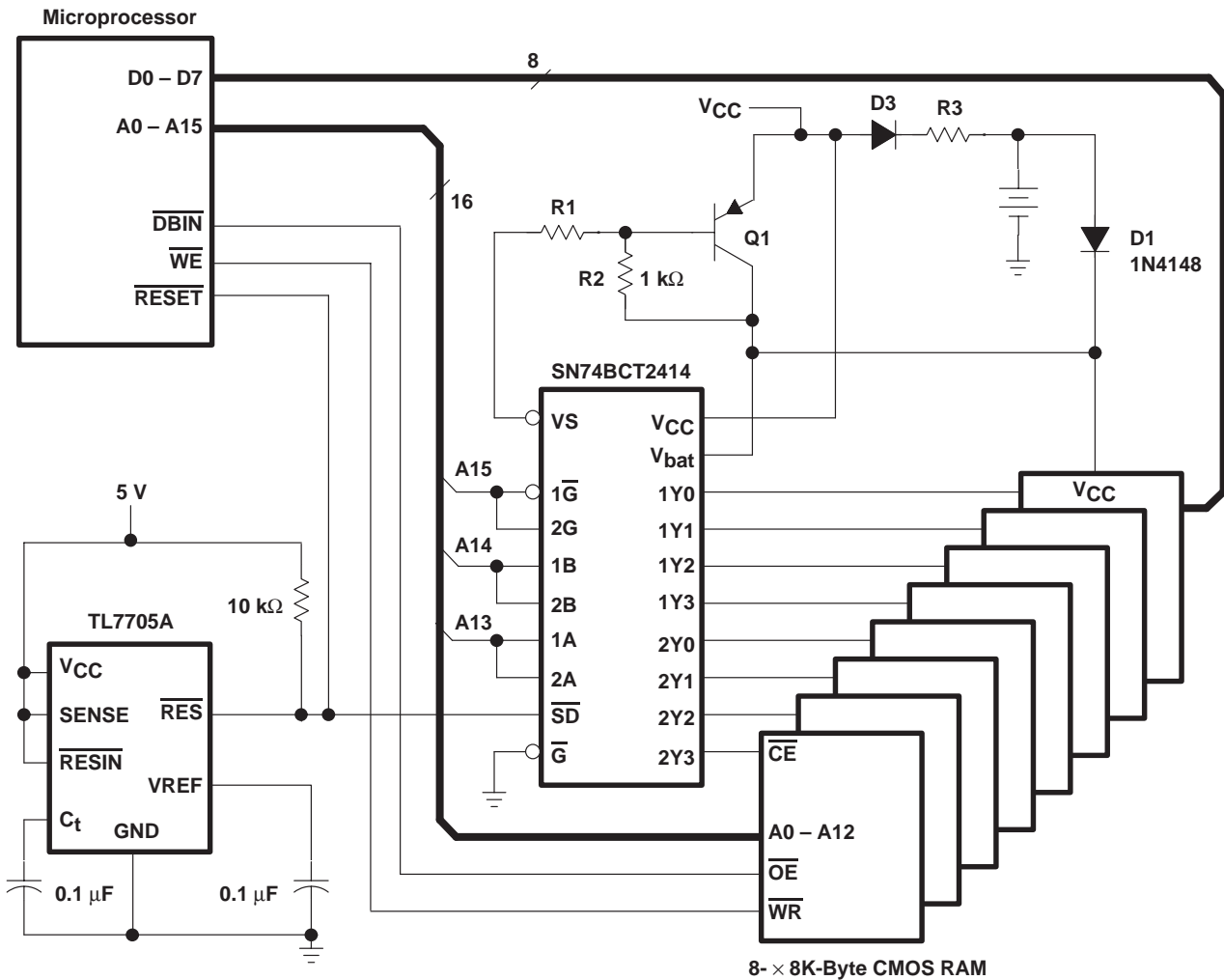

For further information on this device, please contact factory.

Figure 1. Memory System With Battery Backup

IMPORTANT NOTICE

Texas Instruments and its subsidiaries (TI) reserve the right to make changes to their products or to discontinue any product or service without notice, and advise customers to obtain the latest version of relevant information to verify, before placing orders, that information being relied on is current and complete. All products are sold subject to the terms and conditions of sale supplied at the time of order acknowledgement, including those pertaining to warranty, patent infringement, and limitation of liability.

TI warrants performance of its semiconductor products to the specifications applicable at the time of sale in accordance with TI's standard warranty. Testing and other quality control techniques are utilized to the extent TI deems necessary to support this warranty. Specific testing of all parameters of each device is not necessarily performed, except those mandated by government requirements.

CERTAIN APPLICATIONS USING SEMICONDUCTOR PRODUCTS MAY INVOLVE POTENTIAL RISKS OF DEATH, PERSONAL INJURY, OR SEVERE PROPERTY OR ENVIRONMENTAL DAMAGE ("CRITICAL APPLICATIONS"). TI SEMICONDUCTOR PRODUCTS ARE NOT DESIGNED, AUTHORIZED, OR WARRANTED TO BE SUITABLE FOR USE IN LIFE-SUPPORT DEVICES OR SYSTEMS OR OTHER CRITICAL APPLICATIONS. INCLUSION OF TI PRODUCTS IN SUCH APPLICATIONS IS UNDERSTOOD TO BE FULLY AT THE CUSTOMER'S RISK.

In order to minimize risks associated with the customer's applications, adequate design and operating safeguards must be provided by the customer to minimize inherent or procedural hazards.

TI assumes no liability for applications assistance or customer product design. TI does not warrant or represent that any license, either express or implied, is granted under any patent right, copyright, mask work right, or other intellectual property right of TI covering or relating to any combination, machine, or process in which such semiconductor products or services might be or are used. TI's publication of information regarding any third party's products or services does not constitute TI's approval, warranty or endorsement thereof.