

SN74BCT956 OCTAL BUS TRANSCEIVER AND LATCH WITH 3-STATE OUTPUTS

SCBS088A – NOVEMBER 1991 – REVISED NOVEMBER 1993

- State-of-the-Art BiCMOS Design Significantly Reduces I_{CCZ}
- ESD Protection Exceeds 2000 V Per MIL-STD-883C, Method 3015; Exceeds 200 V Using Machine Model ($C = 200$ pF, $R = 0$)
- Latch Version of the 'BCT646
- Independent Latches and Enables for A and B Buses
- Multiplexed Real-Time and Stored Data
- Package Options Include Plastic Small-Outline (DW) Packages and Standard Plastic 300-mil DIPs (NT)

DW OR NT PACKAGE
(TOP VIEW)

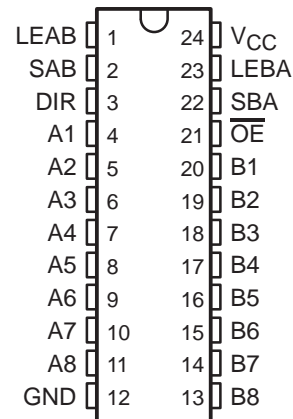

description

The SN74BCT956 consists of bus transceiver circuits, D-type latches, and control circuitry arranged for multiplexed transmission of data directly from the input bus or from the internal latches. Data on the A or B bus is stored in the latches when the appropriate latch-enable (LEAB or LEBA) input is low. Figure 1 illustrates the four fundamental bus-management functions that can be performed with the SN74BCT956.

Output-enable (\overline{OE}) and direction-control (DIR) inputs are provided to control the transceiver functions. In the transceiver mode (\overline{OE} low), data present at the high-impedance port may be stored in either latch or in both.

The select-control (SAB and SBA) inputs can multiplex stored and real-time (transparent mode) data. When the appropriate latch-enable input is high, the latch is transparent, and real-time data is output regardless of the level at the select control.

The direction control (DIR) determines which bus receives data when \overline{OE} is low. In the isolation mode (\overline{OE} high), A data may be stored in one register and/or B data may be stored in the other register.

When an output function is disabled, the input function is still enabled and may be used to store and transmit data. Only one of the two buses, A or B, may be driven at a time.

The SN74BCT956 is characterized for operation from 0°C to 70°C.

SN74BCT956 OCTAL BUS TRANSCEIVER AND LATCH WITH 3-STATE OUTPUTS

SCBS088A – NOVEMBER 1991 – REVISED NOVEMBER 1993

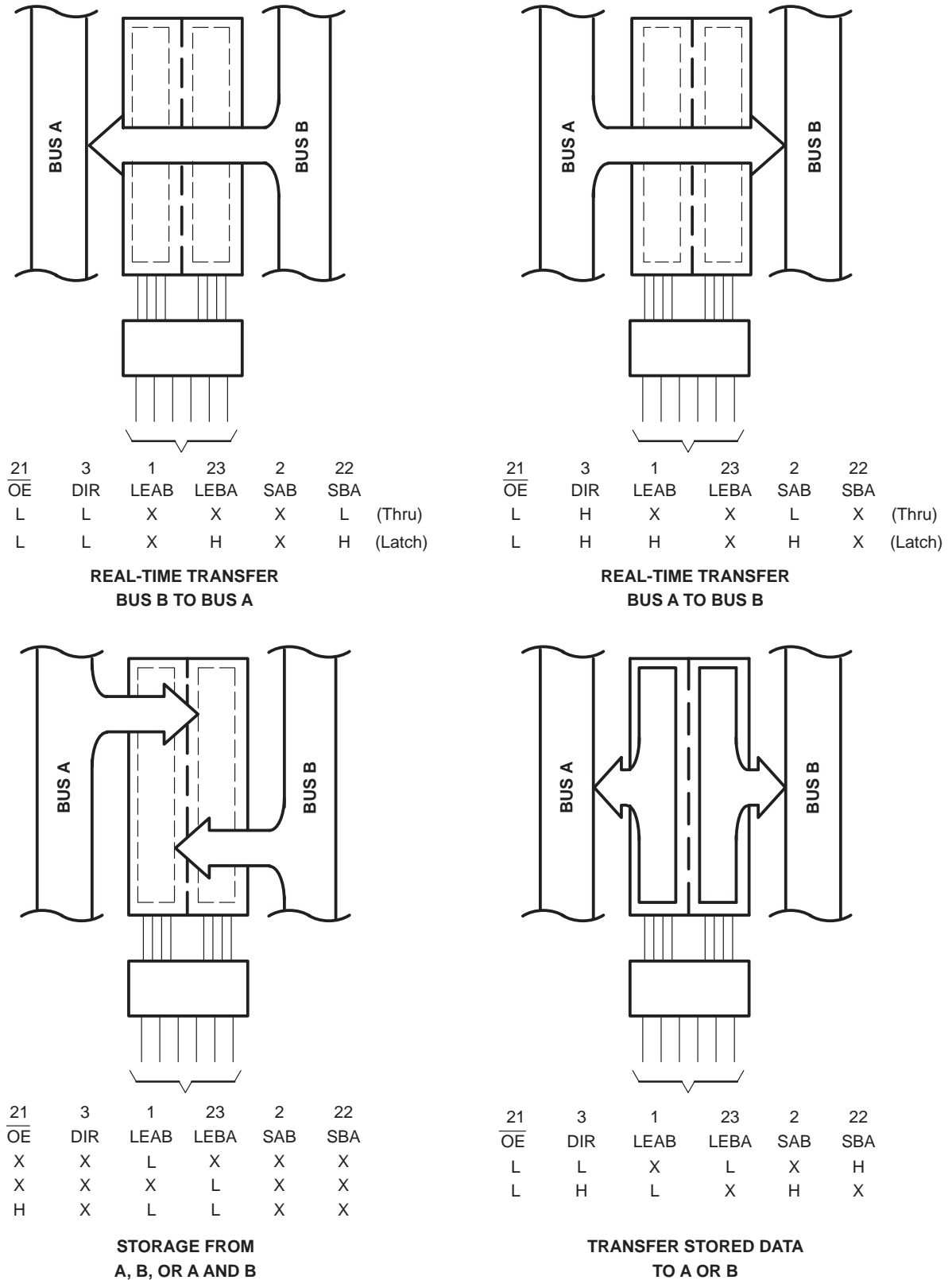

Figure 1. Bus-Management Functions

SN74BCT956 OCTAL BUS TRANSCEIVER AND LATCH WITH 3-STATE OUTPUTS

SCBS088A – NOVEMBER 1991 – REVISED NOVEMBER 1993

FUNCTION TABLE

INPUTS						DATA I/O		OPERATION OR FUNCTION
\overline{OE}	DIR	LEAB	LEBA	SAB	SBA	A1 THRU A8	B1 THRU B8	
X	X	L	X	X	X	Input	Unspecified†	Store A, B unspecified†
X	X	X	L	X	X	Unspecified†	Input	Store B, A unspecified†
L	H	X	X	L	X	Input	Output	A transparent, real-time A data to B bus (thru)
L	H	H	X	H	X	Input	Output	A transparent, real-time A data to B bus (latch)
L	H	L	X	L	X	Input	Output	A data latched, real-time A data to B bus (thru)
L	H	L	X	H	X	Input	Output	A data latched, latched A data to B bus (latch)
L	L	X	X	X	L	Output	Input	B transparent, real-time B data to A bus (thru)
L	L	X	H	X	H	Output	Input	B transparent, real-time B data to A bus (latch)
L	L	X	L	X	L	Output	Input	B data latched, real-time B data to A bus (thru)
L	L	X	L	X	H	Output	Input	B data latched, latched B data to A bus (latch)
H	X	L	L	X	X	Input	Input	Isolation, A and B data latched
H	X	H	H	X	X	Input	Input	Isolation, no storage

† The data output functions may be enabled or disabled by various signals at the \overline{OE} and DIR inputs. Data input functions are always enabled; i.e., data at the bus pins is latched whenever the appropriate latch-enable input is low.

logic symbol‡

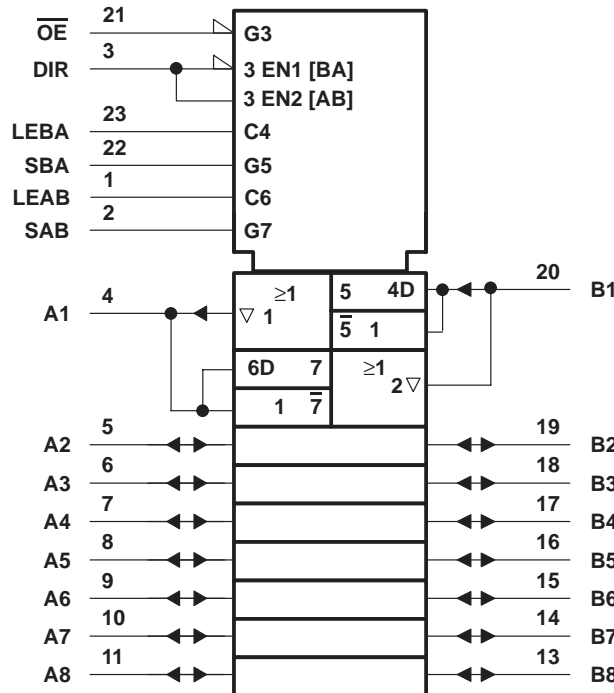

‡ This symbol is in accordance with ANSI/IEEE Std 91-1984 and IEC Publication 617-12.

SN74BCT956 OCTAL BUS TRANSCEIVER AND LATCH WITH 3-STATE OUTPUTS

SCBS088A – NOVEMBER 1991 – REVISED NOVEMBER 1993

logic diagram (positive logic)

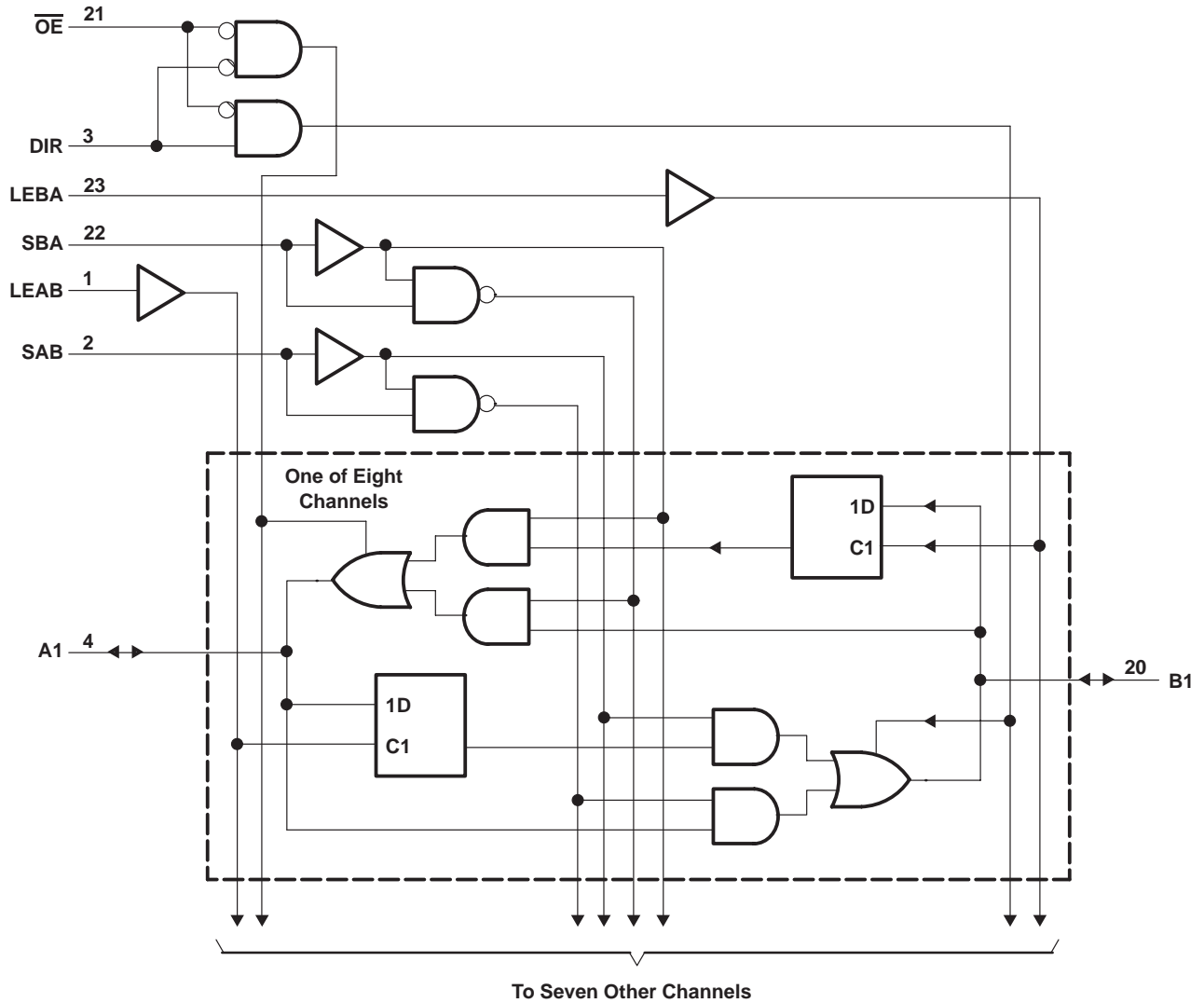

absolute maximum ratings over operating free-air temperature range (unless otherwise noted)†

Supply voltage range, V_{CC}	-0.5 V to 7 V
Input voltage range, V_I (except I/O ports) (see Note 1)	-0.5 V to 7 V
Voltage range applied to any output in the disabled or power-off state, V_O	-0.5 V to 5.5 V
Voltage range applied to any output in the high state, V_{OH}	-0.5 V to V_{CC}
Input clamp current, I_{IK} ($V_I < 0$)	-30 mA
Current into any output in the low state, I_{OL}	128 mA
Operating free-air temperature range	0°C to 70°C
Storage temperature range	-65°C to 150°C

† Stresses beyond those listed under “absolute maximum ratings” may cause permanent damage to the device. These are stress ratings only, and functional operation of the device at these or any other conditions beyond those indicated under “recommended operating conditions” is not implied. Exposure to absolute-maximum-rated conditions for extended periods may affect device reliability.

NOTE 1: The input and output negative-voltage ratings may be exceeded if the input and output clamp-current ratings are observed.

SN74BCT956

OCTAL BUS TRANSCEIVER AND LATCH WITH 3-STATE OUTPUTS

SCBS088A – NOVEMBER 1991 – REVISED NOVEMBER 1993

recommended operating conditions (see Note 2)

		MIN	NOM	MAX	UNIT
V _{CC}	Supply voltage	4.5	5	5.5	V
V _{IH}	High-level input voltage	2			V
V _{IL}	Low-level input voltage			0.8	V
I _{IK}	Input clamp current			-18	mA
I _{OH}	High-level output current			-15	mA
I _{OL}	Low-level output current			64	mA
T _A	Operating free-air temperature	0		70	°C

NOTE 2: Unused or floating pins (input or I/O) must be held high or low.

electrical characteristics over recommended operating free-air temperature range (unless otherwise noted)

PARAMETER		TEST CONDITIONS		MIN	TYP [†]	MAX	UNIT
V _{IK}		V _{CC} = 4.5 V,	I _I = -18 mA			-1.2	V
V _{OH}		V _{CC} = 4.5 V	I _{OH} = -3 mA	2.4	3.3		V
			I _{OH} = -15 mA	2	3.1		
V _{OL}		V _{CC} = 4.5 V,	I _{OL} = 64 mA		0.42	0.55	V
I _I	Any input	V _{CC} = 5.5 V,	V _I = 5.5 V			1	mA
I _{IH} [‡]	A or B ports	V _{CC} = 5.5 V,	V _I = 2.7 V			70	μA
	Control input					20	
I _{IL} [‡]	Any input	V _{CC} = 5.5 V,	V _I = 0.5 V			-0.7	mA
I _{OS} [§]		V _{CC} = 5.5 V,	V _O = 0	-100		-225	mA
I _{CCL}		V _{CC} = 5.5 V,	Outputs open		42	67	mA
I _{CCH}		V _{CC} = 5.5 V,	Outputs open		5	8	mA
I _{CCZ}		V _{CC} = 5.5 V,	Outputs open		6.7	11	mA
C _i	Control input	V _{CC} = 5 V,	V _I = 2.5 V or 0.5 V			5	pF
C _{io}	A to B	V _{CC} = 5 V,	V _O = 2.5 V or 0.5 V			11	pF
	B to A					11	

[†] All typical values are at V_{CC} = 5 V, T_A = 25°C.

[‡] For I/O ports, the parameters I_{IH} and I_{IL} include the off-state output current.

[§] Not more than one output should be tested at a time, and the duration of the test should not exceed one second.

timing requirements over recommended ranges of supply voltage and operating free-air temperature (unless otherwise noted)

		V _{CC} = 5 V, T _A = 25°C		MIN	MAX	UNIT
		MIN	MAX			
t _w	Pulse duration, LE high	4		4		ns
t _{su}	Setup time, data before LE↓	High	0	0		ns
		Low	3	3		
t _h	Hold time, data after LE↓	High	0	0		ns
		Low	2.5	2.5		



SN74BCT956

OCTAL BUS TRANSCEIVER AND LATCH WITH 3-STATE OUTPUTS

SCBS088A – NOVEMBER 1991 – REVISED NOVEMBER 1993

switching characteristics over recommended ranges of supply voltage and operating free-air temperature, $C_L = 50$ pF (unless otherwise noted) (see Note 3)

PARAMETER	FROM (INPUT)	TO (OUTPUT)	$V_{CC} = 5$ V, $T_A = 25^\circ$ C			MIN	MAX	UNIT
			MIN	TYP	MAX			
t_{PLH}	A or B	B or A	2.2	5.1	7.3	2.2	8.3	ns
t_{PHL}	SAB or SBA high (latch)	B or A	3.6	6.7	10	3.6	11.7	
t_{PLH}	A or B	B or A	2	5.1	7.2	2	8.2	ns
t_{PHL}	SAB or SBA low (thru)	B or A	3.3	6.7	9.3	3.3	11.1	
t_{PLH}	LEBA or LEAB	A or B	2.2	5.5	7.9	2.2	9.3	ns
t_{PHL}			2.9	6	8.5	2.9	9.8	
t_{PLH}	SAB or SBA \dagger	B or A	3.7	6.8	10.6	3.7	13.3	ns
t_{PHL}	A or B high		2.6	5.3	7.4	2.6	8.2	
t_{PLH}	SAB or SBA \dagger	B or A	3.2	7.4	9.5	3.2	11.2	ns
t_{PHL}	A or B low		3.8	7.7	10.1	3.8	12.2	
t_{PZH}	\overline{OE}	A or B	3.1	6.9	9.5	3.1	11.7	ns
t_{PZL}			3.9	7.8	10.7	3.9	13.1	
t_{PHZ}	\overline{OE}	A or B	3.5	6.6	8.9	3.5	10.7	ns
t_{PLZ}			2.6	5.9	8.3	2.6	9.5	
t_{PZH}	DIR	A or B	2.1	5	9.8	2.1	12	ns
t_{PZL}			2.9	6	10.9	2.9	13.1	
t_{PHZ}	DIR	A or B	3.6	6.3	10.2	3.6	12.5	ns
t_{PLZ}			2.5	5.7	8.9	2.5	10.8	

\dagger These parameters are measured with the internal output state of the storage register opposite to that of the bus input.

NOTE 3: Load circuits and voltage waveforms are shown in Section 1.

IMPORTANT NOTICE

Texas Instruments and its subsidiaries (TI) reserve the right to make changes to their products or to discontinue any product or service without notice, and advise customers to obtain the latest version of relevant information to verify, before placing orders, that information being relied on is current and complete. All products are sold subject to the terms and conditions of sale supplied at the time of order acknowledgement, including those pertaining to warranty, patent infringement, and limitation of liability.

TI warrants performance of its semiconductor products to the specifications applicable at the time of sale in accordance with TI's standard warranty. Testing and other quality control techniques are utilized to the extent TI deems necessary to support this warranty. Specific testing of all parameters of each device is not necessarily performed, except those mandated by government requirements.

CERTAIN APPLICATIONS USING SEMICONDUCTOR PRODUCTS MAY INVOLVE POTENTIAL RISKS OF DEATH, PERSONAL INJURY, OR SEVERE PROPERTY OR ENVIRONMENTAL DAMAGE ("CRITICAL APPLICATIONS"). TI SEMICONDUCTOR PRODUCTS ARE NOT DESIGNED, AUTHORIZED, OR WARRANTED TO BE SUITABLE FOR USE IN LIFE-SUPPORT DEVICES OR SYSTEMS OR OTHER CRITICAL APPLICATIONS. INCLUSION OF TI PRODUCTS IN SUCH APPLICATIONS IS UNDERSTOOD TO BE FULLY AT THE CUSTOMER'S RISK.

In order to minimize risks associated with the customer's applications, adequate design and operating safeguards must be provided by the customer to minimize inherent or procedural hazards.

TI assumes no liability for applications assistance or customer product design. TI does not warrant or represent that any license, either express or implied, is granted under any patent right, copyright, mask work right, or other intellectual property right of TI covering or relating to any combination, machine, or process in which such semiconductor products or services might be or are used. TI's publication of information regarding any third party's products or services does not constitute TI's approval, warranty or endorsement thereof.