

# CD74FCT842A

## BiCMOS 10-BIT BUS-INTERFACE D-TYPE LATCH WITH 3-STATE OUTPUTS

SCBS726 – JULY 2000

- BiCMOS Technology With Low Quiescent Power
- Buffered Inputs
- Inverted Outputs
- Input/Output Isolation From  $V_{CC}$
- Controlled Output Edge Rates
- 48-mA Output Sink Current
- Output Voltage Swing Limited to 3.7 V
- SCR Latch-Up-Resistant BiCMOS Process and Circuit Design
- Packaged in Plastic Small-Outline Package

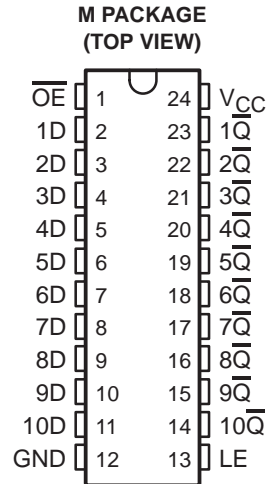

### description

The CD74FCT842A is a 10-bit, D-type latch with 3-state outputs, designed specifically for driving highly capacitive or relatively low-impedance loads. It is particularly suitable for implementing buffer registers, I/O ports, bidirectional bus drivers, and working registers. The device provides extra data width for wider address/data paths or buses carrying parity. The latches are transparent D-type latches. The device provides inverted outputs.

The device uses a small-geometry BiCMOS technology. The output stage is a combination of bipolar and CMOS transistors that limits the output high level to two diode drops below  $V_{CC}$ . This resultant lowering of output swing (0 V to 3.7 V) reduces power-bus ringing [a source of electromagnetic interference (EMI)] and minimizes  $V_{CC}$  bounce and ground bounce and their effects during simultaneous output switching. The output configuration also enhances switching speed and is capable of sinking 48 mA.

The CD74FCT842A outputs are transparent to the inputs when the latch-enable (LE) input is high. When LE goes low, the data is latched. The output-enable ( $\overline{OE}$ ) input controls the 3-state outputs. When  $\overline{OE}$  is high, the outputs are in the high-impedance state. The latch operation is independent of the state of  $\overline{OE}$ .

$\overline{OE}$  does not affect the internal operations of the latch. Previously stored data can be retained or new data can be entered while the outputs are in the high-impedance state.

The CD74FCT842A is characterized for operation from 0°C to 70°C.

**FUNCTION TABLE**  
(each latch)

INPUTS			OUTPUT
$\overline{OE}$	LE	D	$\overline{Q}$
L	H	H	L
L	H	L	H
L	L	X	$Q_0$
H	X	X	Z



Please be aware that an important notice concerning availability, standard warranty, and use in critical applications of Texas Instruments semiconductor products and disclaimers thereto appears at the end of this data sheet.

PRODUCTION DATA information is current as of publication date. Products conform to specifications per the terms of Texas Instruments standard warranty. Production processing does not necessarily include testing of all parameters.

**TEXAS  
INSTRUMENTS**

POST OFFICE BOX 655303 • DALLAS, TEXAS 75265

Copyright © 2000, Texas Instruments Incorporated

# CD74FCT842A BiCMOS 10-BIT BUS-INTERFACE D-TYPE LATCH WITH 3-STATE OUTPUTS

SCBS726 – JULY 2000

## logic symbol†

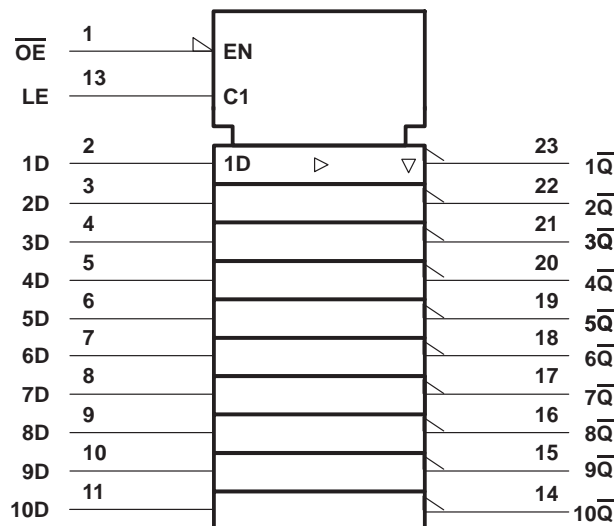

† This symbol is in accordance with ANSI/IEEE Std 91-1984 and IEC Publication 617-12.

## logic diagram (positive logic)

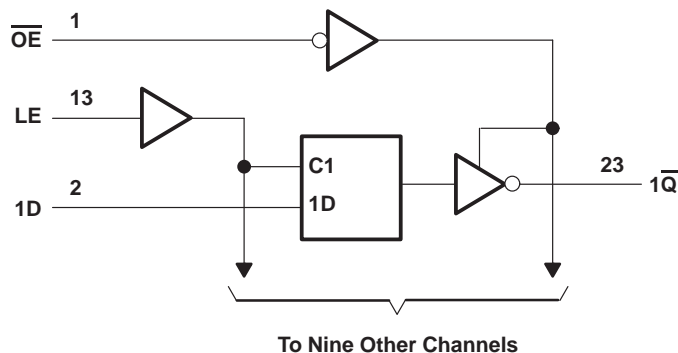

## absolute maximum ratings over operating free-air temperature range (unless otherwise noted)‡

DC supply voltage range, $V_{CC}$ .....	-0.5 V to 6 V
DC input clamp current, $I_{IK}$ ( $V_I < -0.5$ V) .....	-20 mA
DC output clamp current, $I_{OK}$ ( $V_O < -0.5$ V) .....	-50 mA
DC output sink current per output pin, $I_{OL}$ .....	70 mA
DC output source current per output pin, $I_{OH}$ .....	-30 mA
Continuous current through $V_{CC}$ , $I_{CC}$ .....	260 mA
Continuous current through GND .....	500 mA
Package thermal impedance, $\theta_{JA}$ (see Note 1) .....	46°C/W
Storage temperature range, $T_{stg}$ .....	-65°C to 150°C

‡ Stresses beyond those listed under “absolute maximum ratings” may cause permanent damage to the device. These are stress ratings only, and functional operation of the device at these or any other conditions beyond those indicated under “recommended operating conditions” is not implied. Exposure to absolute-maximum-rated conditions for extended periods may affect device reliability.

NOTE 1: The package thermal impedance is calculated in accordance with JESD 51.

# CD74FCT842A

## BICMOS 10-BIT BUS-INTERFACE D-TYPE LATCH WITH 3-STATE OUTPUTS

SCBS726 – JULY 2000

### recommended operating conditions (see Note 2)

		MIN	MAX	UNIT
V <sub>CC</sub>	Supply voltage	4.75	5.25	V
V <sub>IH</sub>	High-level input voltage	2		V
V <sub>IL</sub>	Low-level input voltage		0.8	V
V <sub>I</sub>	Input voltage	0	V <sub>CC</sub>	V
V <sub>O</sub>	Output voltage	0	V <sub>CC</sub>	V
I <sub>OH</sub>	High-level output current		-15	mA
I <sub>OL</sub>	Low-level output current		48	mA
Δt/Δv	Input transition rise or fall rate	0	10	ns/V
T <sub>A</sub>	Operating free-air temperature	0	70	°C

NOTE 2: All unused inputs of the device must be held at V<sub>CC</sub> or GND to ensure proper device operation. Refer to the TI application report, *Implications of Slow or Floating CMOS Inputs*, literature number SCBA004.

### electrical characteristics over recommended operating temperature range (unless otherwise noted)

PARAMETER	TEST CONDITIONS	V <sub>CC</sub>	T <sub>A</sub> = 25°C		MIN	MAX	UNIT
			MIN	MAX			
V <sub>IK</sub>	I <sub>I</sub> = -18 mA	4.75 V		-1.2		-1.2	V
V <sub>OH</sub>	I <sub>OH</sub> = -15 mA	4.75 V	2.4		2.4		V
V <sub>OL</sub>	I <sub>OL</sub> = 48 mA	4.75 V	0.55		0.55		V
I <sub>I</sub>	V <sub>I</sub> = V <sub>CC</sub> or GND	5.25 V		±0.1		±1	μA
I <sub>OZ</sub>	V <sub>O</sub> = V <sub>CC</sub> or GND	5.25 V		±0.5		±10	μA
I <sub>OS</sub> <sup>†</sup>	V <sub>I</sub> = V <sub>CC</sub> or GND, V <sub>O</sub> = 0	5.25 V		-75		-75	mA
I <sub>CC</sub>	V <sub>I</sub> = V <sub>CC</sub> or GND, I <sub>O</sub> = 0	5.25 V		8		80	μA
ΔI <sub>CC</sub> <sup>‡</sup>	One input at 3.4 V, Other inputs at V <sub>CC</sub> or GND	5.25 V		1.6		1.6	mA
C <sub>i</sub>	V <sub>I</sub> = V <sub>CC</sub> or GND			10		10	pF
C <sub>o</sub>	V <sub>O</sub> = V <sub>CC</sub> or GND			15		15	pF

<sup>†</sup> Not more than one output should be tested at a time, and the duration of the test should not exceed 100 ms.

<sup>‡</sup> This is the increase in supply current for each input at one of the specified TTL voltage levels rather than 0 V or V<sub>CC</sub>.

### timing requirements over recommended operating temperature conditions (unless otherwise noted) (see Figure 1)

		MIN	MAX	UNIT
t <sub>w</sub>	Pulse duration	4		ns
t <sub>su</sub>	Setup time	Data before LE↓	2.5	ns
t <sub>h</sub>	Hold time	Data after LE↓	2.5	ns

### switching characteristics over recommended operating temperature conditions (unless otherwise noted) (see Figure 1)

PARAMETER	FROM (INPUT)	TO (OUTPUT)	T <sub>A</sub> = 25°C	MIN	MAX	UNIT
			TYP			
t <sub>pd</sub>	D	$\bar{Q}$	7.5	1.5	10	ns
	LE		9	2	12	
t <sub>en</sub>	$\overline{OE}$	$\bar{Q}$	8.6	1.5	11.5	ns
t <sub>dis</sub>	$\overline{OE}$	$\bar{Q}$	6	1.5	8	ns



**CD74FCT842A**  
**BiCMOS 10-BIT BUS-INTERFACE D-TYPE LATCH**  
**WITH 3-STATE OUTPUTS**

SCBS726 – JULY 2000

**noise characteristics,  $V_{CC} = 5\text{ V}$ ,  $C_L = 50\text{ pF}$ ,  $T_A = 25^\circ\text{C}$**

PARAMETER		MIN	TYP	MAX	UNIT
$V_{OL(P)}$	Quiet output, maximum dynamic $V_{OL}$		1		V
$V_{OH(V)}$	Quiet output, minimum dynamic $V_{OH}$		0.5		V
$V_{IH(D)}$	High-level dynamic input voltage	2			V
$V_{IL(D)}$	Low-level dynamic input voltage			0.8	V

PARAMETER MEASUREMENT INFORMATION

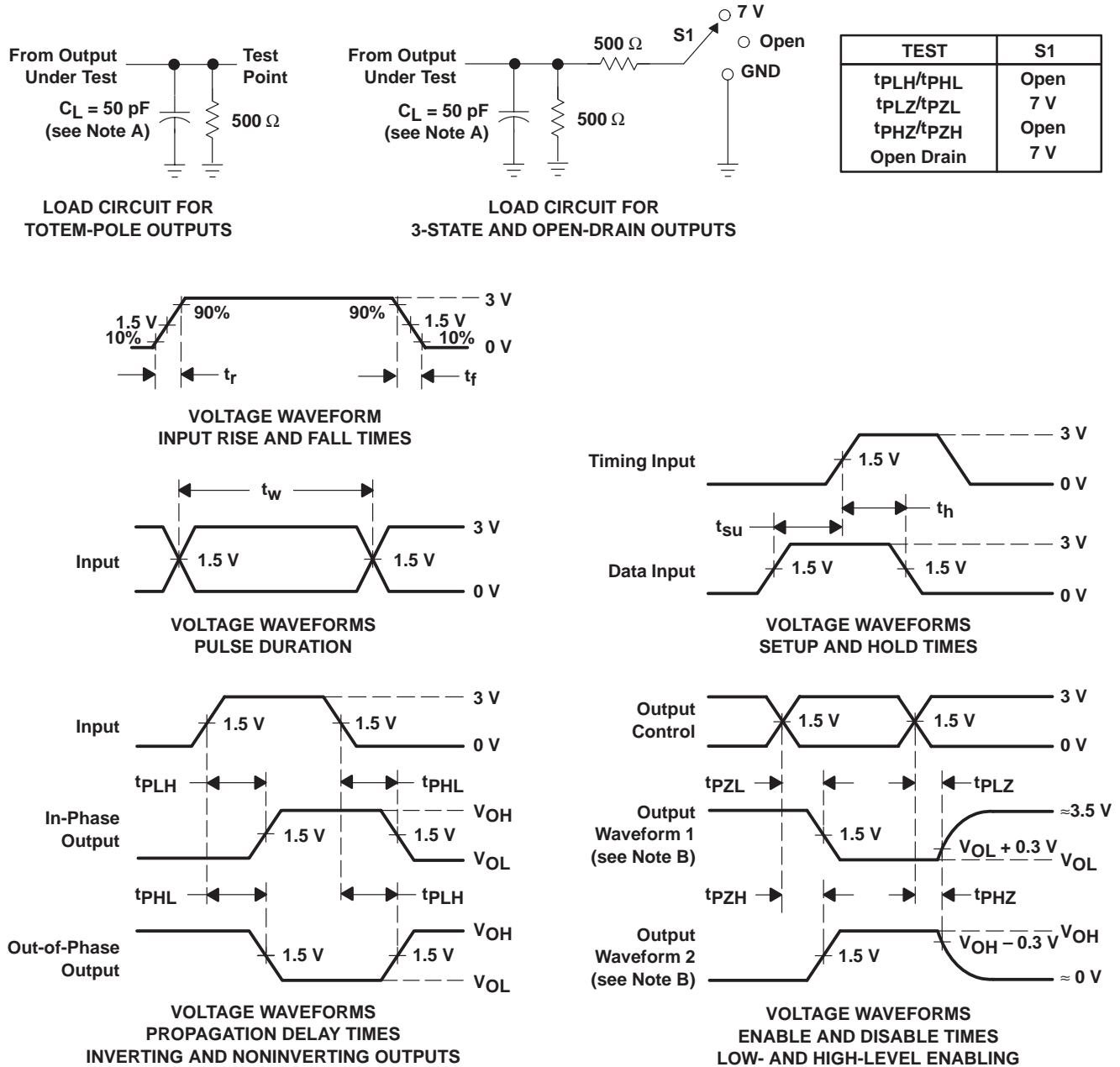

- NOTES: A. C<sub>L</sub> includes probe and jig capacitance.  
 B. Waveform 1 is for an output with internal conditions such that the output is low except when disabled by the output control. Waveform 2 is for an output with internal conditions such that the output is high except when disabled by the output control.  
 C. All input pulses are supplied by generators having the following characteristics: PRR ≤ 1 MHz, Z<sub>O</sub> = 50 Ω, t<sub>r</sub> and t<sub>f</sub> = 2.5 ns.  
 D. The outputs are measured one at a time with one input transition per measurement.  
 E. t<sub>PLZ</sub> and t<sub>PHZ</sub> are the same as t<sub>dis</sub>.  
 F. t<sub>PZL</sub> and t<sub>PZH</sub> are the same as t<sub>en</sub>.  
 G. t<sub>PHL</sub> and t<sub>PLH</sub> are the same as t<sub>pd</sub>.

Figure 1. Load Circuit and Voltage Waveforms

## **IMPORTANT NOTICE**

Texas Instruments and its subsidiaries (TI) reserve the right to make changes to their products or to discontinue any product or service without notice, and advise customers to obtain the latest version of relevant information to verify, before placing orders, that information being relied on is current and complete. All products are sold subject to the terms and conditions of sale supplied at the time of order acknowledgment, including those pertaining to warranty, patent infringement, and limitation of liability.

TI warrants performance of its semiconductor products to the specifications applicable at the time of sale in accordance with TI's standard warranty. Testing and other quality control techniques are utilized to the extent TI deems necessary to support this warranty. Specific testing of all parameters of each device is not necessarily performed, except those mandated by government requirements.

Customers are responsible for their applications using TI components.

In order to minimize risks associated with the customer's applications, adequate design and operating safeguards must be provided by the customer to minimize inherent or procedural hazards.

TI assumes no liability for applications assistance or customer product design. TI does not warrant or represent that any license, either express or implied, is granted under any patent right, copyright, mask work right, or other intellectual property right of TI covering or relating to any combination, machine, or process in which such semiconductor products or services might be or are used. TI's publication of information regarding any third party's products or services does not constitute TI's approval, warranty or endorsement thereof.