

SN10KHT5540 OCTAL ECL-TO-TTL TRANSLATOR WITH 3-STATE OUTPUTS

SDZS006 – DECEMBER 1990

- 10KH Compatible
- ECL and TTL Control Inputs
- Inverting Outputs
- Flow-Through Architecture Optimizes PCB Layout
- Center Pin V_{CC} , V_{EE} , and GND Configurations Minimize High-Speed Switching Noise
- Package Options Include “Small Outline” Packages and Standard Plastic 300-mil DIPs

description

This octal ECL-to-TTL translator is designed to provide a efficient translation between a 10KH ECL signal environment and a TTL signal environment. This device is designed specifically to improve the performance and density of ECL-to-TTL CPU/bus-oriented functions such as memory-address drivers, clock drivers, and bus-oriented receivers and transmitters.

Two output enable pins, $\overline{OE}1$ and $\overline{OE}2$, are provided. These control inputs are ANDed together with $\overline{OE}1$ being ECL compatible and $\overline{OE}2$ being TTL compatible. This offers the choice of controlling the outputs of the device from either a TTL or ECL signal environment.

The SN10KHT5540 is characterized for operation from 0°C to 75°C.

FUNCTION TABLE

OUTPUT ENABLE		DATA INPUT A	OUTPUT (TTL)
$\overline{OE}1$	$\overline{OE}2$		Y
X	H	X	Z
H	X	X	Z
L	L	L	H
L	L	H	L

DW OR NT PACKAGE
(TOP VIEW)

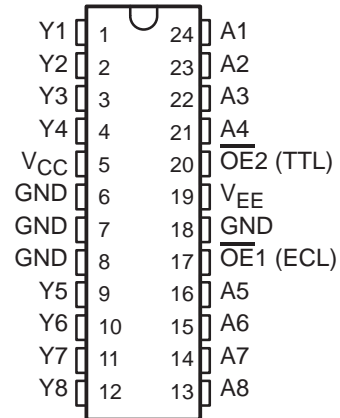

logic symbol†

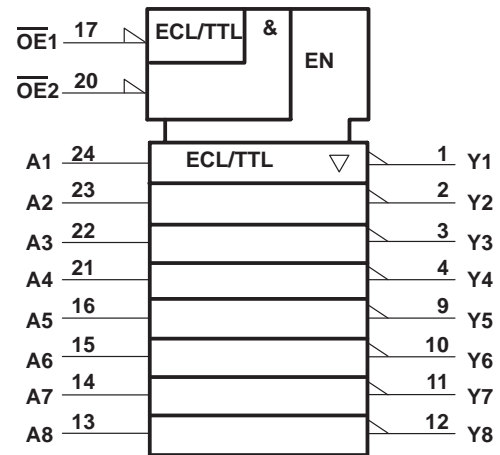

† This symbol is in accordance with ANSI/IEEE STD 91-1984 and IEC Publication 617-12.

SN10KHT5540
OCTAL ECL-TO-TTL TRANSLATOR
WITH 3-STATE OUTPUTS
SDZS006 – DECEMBER 1990

logic diagram (positive logic)

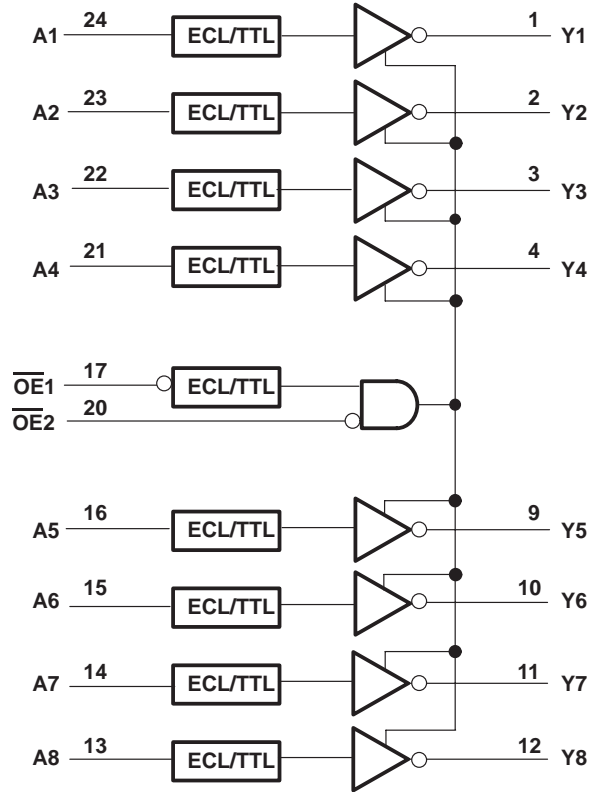

absolute maximum ratings over operating free-air temperature range (unless otherwise noted)†

Supply voltage range, V_{CC}	–0.5 V to 7 V
Supply voltage range, V_{EE}	–8 V to 0 V
Input voltage range (TTL) (see Note 1)	–1.2 V to 7 V
Input voltage range (ECL)	V_{EE} to 0 V
Voltage applied to any output in the disabled or power-off state	–0.5 V to 5.5 V
Voltage applied to any output in the high state	–0.5 V to V_{CC}
Input current range (TTL)	–30 mA to 5 mA
Current into any output in the low state	96 mA
Operating free-air temperature range	0°C to 75°C
Storage temperature range	–65°C to 150°C

Stresses beyond those listed under “absolute maximum ratings” may cause permanent damage to the device. These are stress ratings only and functional operation of the device at these or any other conditions beyond those indicated under “recommended operating conditions” is not implied. Exposure to absolute-maximum-rated conditions for extended periods may affect device reliability.

NOTE 1: The TTL input voltage ratings may be exceeded provided the input current ratings are observed.

recommended operating conditions

		MIN	NOM	MAX	UNIT
V_{CC}	TTL supply voltage	4.5	5	5.5	V
V_{EE}	ECL supply voltage	–4.94	–5.2	–5.46	V
V_{IH}	TTL high-level input voltage	2			V
V_{IL}	TTL low-level input voltage			0.8	V
V_{IH}^{\ddagger}	ECL high-level input voltage	$T_A = 0^\circ\text{C}$		–840	mV
		$T_A = 25^\circ\text{C}$	–1130	–810	
		$T_A = 75^\circ\text{C}$	–1070	–735	
V_{IL}^{\ddagger}	ECL low-level input voltage	$T_A = 0^\circ\text{C}$	–1950	–1480	mV
		$T_A = 25^\circ\text{C}$	–1950	–1480	
		$T_A = 75^\circ\text{C}$	–1950	–1450	
I_{IK}	TTL input clamp current			–18	mA
I_{OH}	High-level output current			–15	mA
I_{OL}	Low-level output current			48	mA
T_A	Operating free-air temperature	0		75	°C

† The algebraic convention, in which the least positive (most negative) value is designated minimum, is used in this data sheet for logic levels only.

SN10KHT5540
OCTAL ECL-TO-TTL TRANSLATOR
WITH 3-STATE OUTPUTS

SDZS006 – DECEMBER 1990

electrical characteristics over recommended operating free-air temperature range (unless otherwise noted)

PARAMETER		TEST CONDITIONS		MIN	TYP [†]	MAX	UNIT
V _{IK}	$\overline{OE}2$ only	V _{CC} = 4.5 V, V _{EE} = -4.94 V, I _I = -18 mA				-1.2	V
V _{OH}		V _{CC} = 4.5 V, V _{EE} = -5.2 V ± 5%, I _{OH} = -3 mA		2.4	3.3		V
		V _{CC} = 4.5 V, V _{EE} = -5.2 V ± 5%, I _{OH} = -15 mA		2	3.1		
V _{OL}		V _{CC} = 4.5 V, V _{EE} = -5.2 V ± 5%, I _{OL} = 48 mA		0.38	0.55		V
I _I	$\overline{OE}2$ only	V _{CC} = 5.5 V, V _{EE} = -5.46 V, V _I = 7 V				0.1	mA
I _{IH}	$\overline{OE}2$ only	V _{CC} = 5.5 V, V _{EE} = -5.46 V, V _I = 2.7 V				20	μA
I _{IL}	$\overline{OE}2$ only	V _{CC} = 5.5 V, V _{EE} = -5.46 V, V _I = 0.5 V				-0.5	mA
I _{IH}	Data inputs and $\overline{OE}1$	V _{CC} = 5.5 V, V _{EE} = -5.46 V, V _I = -840 mV	T _A = 0°C			350	μA
		V _{CC} = 5.5 V, V _{EE} = -5.46 V, V _I = -810 mV	T _A = 25°C			350	
		V _{CC} = 5.5 V, V _{EE} = -5.46 V, V _I = -735 mV	T _A = 75°C			350	
I _{IL}	Data inputs and $\overline{OE}1$	V _{CC} = 5.5 V, V _{EE} = -5.46 V, V _I = -1950 mV	T _A = 0°C	0.5			μA
			T _A = 25°C	0.5			
			T _A = 75°C	0.5			
I _{OZH}		V _{CC} = 5.5 V, V _{EE} = -5.46 V, V _O = 2.7 V				50	μA
I _{OZL}		V _{CC} = 5.5 V, V _{EE} = -5.46 V, V _O = 0.5 V				-50	μA
I _{OS} [‡]		V _{CC} = 5.5 V, V _{EE} = -5.46 V, V _O = 0		-100		-225	mA
I _{CCH}		V _{CC} = 5.5 V, V _{EE} = -5.46 V			67	97	mA
I _{CCL}		V _{CC} = 5.5 V, V _{EE} = -5.46 V			84	120	mA
I _{CCZ}		V _{CC} = 5.5 V, V _{EE} = -5.46 V			81	116	mA
I _{EE}		V _{CC} = 5.5 V, V _{EE} = -5.46 V			-23	-33	mA
C _i		V _{CC} = 5 V, V _{EE} = -5.2 V			5		pF
C _o		V _{CC} = 5 V, V _{EE} = -5.2 V			7		pF

[†] All typical values are at V_{CC} = 5 V, V_{EE} = -5.2 V, T_A = 25°C.

[‡] Not more than one output should be tested at a time and the duration of the test should not exceed 10 ms.

switching characteristics over recommended ranges of operating free-air temperature and supply voltage (see Figure 1)

PARAMETER	FROM (INPUT)	TO (OUTPUT)	C _L = 50 pF, R ₁ = 500 Ω, R ₂ = 500 Ω			UNIT
			MIN	TYP [§]	MAX	
t _{PLH}	A	Y	1.6	3.9	6.4	ns
t _{PHL}			1.6	4.2	6.4	
t _{PZH}	$\overline{OE}1$	Y	2.4	4.5	6.9	ns
t _{PZL}			3.5	5.9	8.7	
t _{PHZ}	$\overline{OE}1$	Y	2.8	5.2	8.1	ns
t _{PLZ}			2.2	4.6	8	
t _{PZH}	$\overline{OE}2$	Y	1.4	3.3	6.1	ns
t _{PZL}			2.5	4.7	7.9	
t _{PHZ}	$\overline{OE}2$	Y	1.6	4.1	6.5	ns
t _{PLZ}			0.7	3.3	6.4	

[§] All typical values are at V_{CC} = 5 V, V_{EE} = -5.2 V, T_A = 25°C.



PARAMETER MEASUREMENT INFORMATION

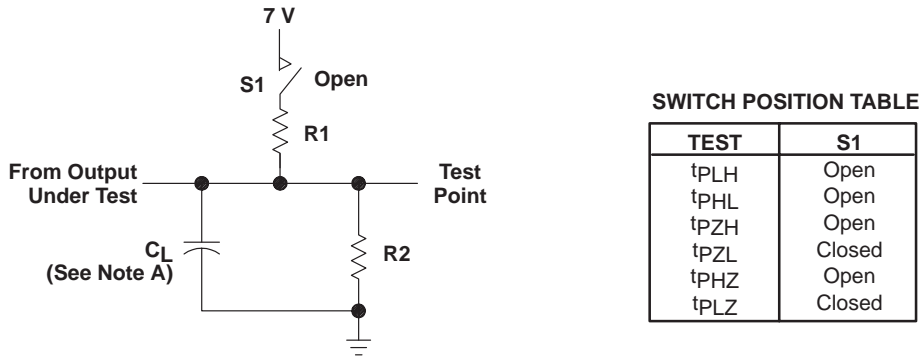

SWITCH POSITION TABLE

TEST	S1
t _{PLH}	Open
t _{PHL}	Open
t _{PZH}	Open
t _{PZL}	Closed
t _{PHZ}	Open
t _{PLZ}	Closed

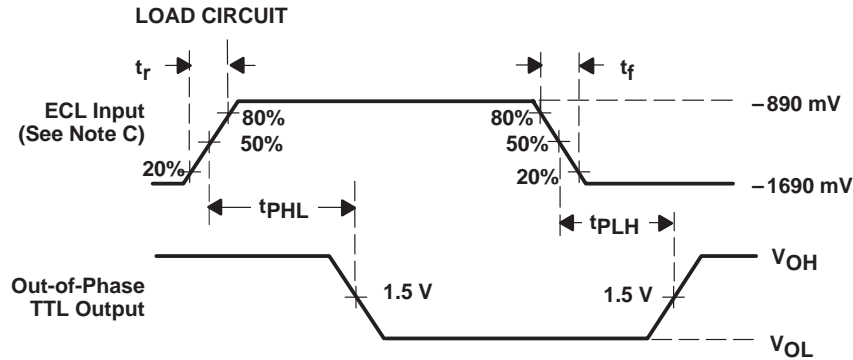

ECL INPUT PROPAGATION DELAY TIMES

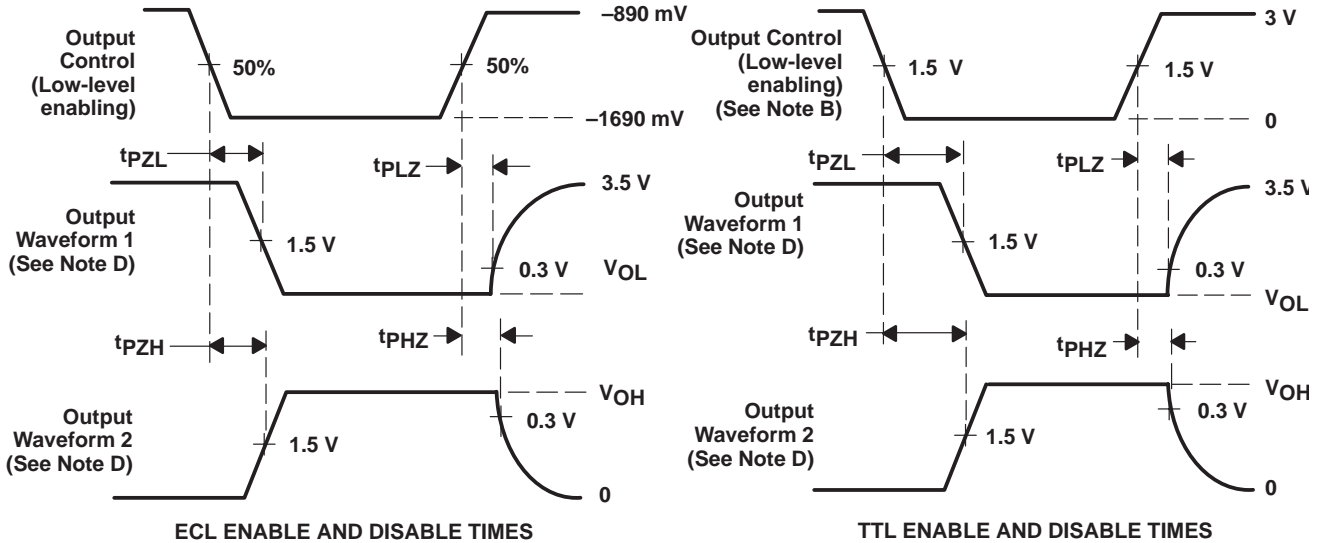

- NOTES: A. C_L includes probe and jig capacitance.
 B. For TTL inputs, input pulses are supplied by generators having the following characteristics: PRR ≤ 10 MHz, Z₀ = 50 Ω, t_r ≤ 2.5 ns, t_f ≤ 2.5 ns.
 C. For ECL inputs, input pulses are supplied by generators having the following characteristics: PRR ≤ 10 MHz, Z₀ = 50 Ω, t_r ≤ 1.5 ns, t_f ≤ 1.5 ns.
 D. Waveform 1 is for an output with internal conditions such that the output is low except when disabled by the output control. Waveform 2 is for an output with internal conditions such that the output is high except when disabled by the output control.
 E. The outputs are measured one at a time with one transition per measurement.

FIGURE 1. LOAD CIRCUIT AND VOLTAGE WAVEFORMS

IMPORTANT NOTICE

Texas Instruments and its subsidiaries (TI) reserve the right to make changes to their products or to discontinue any product or service without notice, and advise customers to obtain the latest version of relevant information to verify, before placing orders, that information being relied on is current and complete. All products are sold subject to the terms and conditions of sale supplied at the time of order acknowledgement, including those pertaining to warranty, patent infringement, and limitation of liability.

TI warrants performance of its semiconductor products to the specifications applicable at the time of sale in accordance with TI's standard warranty. Testing and other quality control techniques are utilized to the extent TI deems necessary to support this warranty. Specific testing of all parameters of each device is not necessarily performed, except those mandated by government requirements.

CERTAIN APPLICATIONS USING SEMICONDUCTOR PRODUCTS MAY INVOLVE POTENTIAL RISKS OF DEATH, PERSONAL INJURY, OR SEVERE PROPERTY OR ENVIRONMENTAL DAMAGE ("CRITICAL APPLICATIONS"). TI SEMICONDUCTOR PRODUCTS ARE NOT DESIGNED, AUTHORIZED, OR WARRANTED TO BE SUITABLE FOR USE IN LIFE-SUPPORT DEVICES OR SYSTEMS OR OTHER CRITICAL APPLICATIONS. INCLUSION OF TI PRODUCTS IN SUCH APPLICATIONS IS UNDERSTOOD TO BE FULLY AT THE CUSTOMER'S RISK.

In order to minimize risks associated with the customer's applications, adequate design and operating safeguards must be provided by the customer to minimize inherent or procedural hazards.

TI assumes no liability for applications assistance or customer product design. TI does not warrant or represent that any license, either express or implied, is granted under any patent right, copyright, mask work right, or other intellectual property right of TI covering or relating to any combination, machine, or process in which such semiconductor products or services might be or are used. TI's publication of information regarding any third party's products or services does not constitute TI's approval, warranty or endorsement thereof.