

THS6042, THS6043 200 mA REMOTE TERMINAL ADSL LINE DRIVERS

SLOS264A – MARCH 2000 – REVISED – MAY 2000

- Remote Terminal ADSL Line Driver
 - Ideal for Both Full Rate ADSL and G.Lite
 - Compatible With Either 1:1 or 1:2 Transformer Ratios
- Wide Output Swing
 - 43 Vp-p Differential Output Voltage, $R_L = 200 \Omega$, ± 12 V Supply
 - 19 Vp-p Differential Output Voltage, $R_L = 50 \Omega$, 12 V Single Supply
- High Output Current
 - 200 mA (min)
- Low Distortion, Single-Ended, $G = 4$
 - -77 dBc (250 kHz, 2 Vp-p, 25Ω load)
 - -85 dBc (250 kHz, 2 Vp-p, 100Ω load)
- Low Power Shutdown (THS6043)
 - 300 μ A Total Standby Current
- High Speed
 - 80 MHz (-3 dB, $G=1$, 12 V Single Supply)
 - 800 V/ μ s Slew Rate ($G = 4$, 12 V Single Supply)
- Wide Supply Voltage Range ± 2.5 V to ± 15 V
 - Ideal for Single Supply 12-V Operation
- Thermal Shutdown and Short Circuit Protection
- Standard SOIC and Small TSSOP PowerPAD™ Package
- Evaluation Module Available

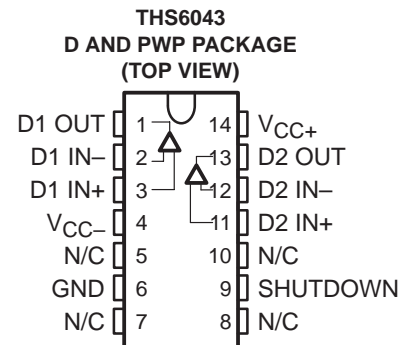
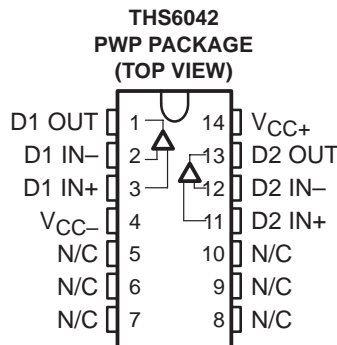
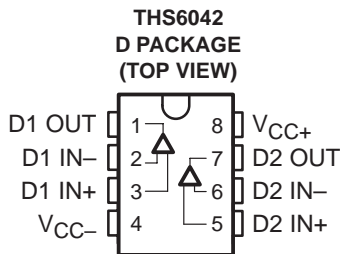

description

The THS6042/3 is a high-speed line driver ideal for driving signals from the remote terminal to the central office in asymmetrical digital subscriber line (ADSL) applications. It can operate from a single 12-V supply voltage while drawing only 6.5 mA of supply current per channel. It offers low -77 dBc total harmonic distortion driving a 25Ω load (2 Vp-p). The THS6042/3 offers a high 19-Vp-p differential output swing across a $50\text{-}\Omega$ load from a single 12-V supply. The THS6043 features a low-power shutdown mode, consuming only 150 μ A quiescent current per channel. The THS6042/3 is packaged in a standard SOIC and a small TSSOP PowerPAD™ package.

HIGH-SPEED xDSL LINE DRIVER/RECEIVER FAMILY

DEVICE	DRIVER	RECEIVER	5 V	± 5 V	± 15 V	DESCRIPTION
THS6002	●	●		●	●	500-mA differential line driver and receiver
THS6012	●			●	●	500-mA differential line driver
THS6022	●			●	●	250-mA differential line driver
THS6032	●			●	●	500-mA low-power ADSL central-office line driver
THS6042/3	●		●	●	●	200-mA remote terminal ADSL line driver
THS6052/3	●		●	●	●	100-mA remote terminal ADSL line driver
THS6062		●	●	●	●	Low-noise ADSL receiver
THS6072		●		●	●	Low-power ADSL receiver
THS7002		●		●	●	Low-noise programmable-gain ADSL receiver



Please be aware that an important notice concerning availability, standard warranty, and use in critical applications of Texas Instruments semiconductor products and disclaimers thereto appears at the end of this data sheet.

PowerPAD is a trademark of Texas Instruments.

PRODUCT PREVIEW information concerns products in the formative or design phase of development. Characteristic data and other specifications are design goals. Texas Instruments reserves the right to change or discontinue these products without notice.



POST OFFICE BOX 655303 • DALLAS, TEXAS 75265

Copyright © 2000, Texas Instruments Incorporated

PRODUCT PREVIEW

THS6042, THS6043 200 mA REMOTE TERMINAL ADSL LINE DRIVERS

SLOS264A – MARCH 2000 – REVISED – MAY 2000

AVAILABLE OPTIONS

T _A	PACKAGED DEVICE			EVALUATION MODULES
	SOIC-8 (D)	SOIC-14 (D)	TSSOP-14 (PWP)	
0°C to 70°C	THS6042CD —	THS6043CD —	THS6042CPWP THS6043CPWP	THS6042EVM THS6043EVM
-40°C to 85°C	THS6042ID —	THS6043ID —	THS6042IPWP THS6043IPWP	— —

block diagrams

The block diagrams are shown in Figures 1 through 3.

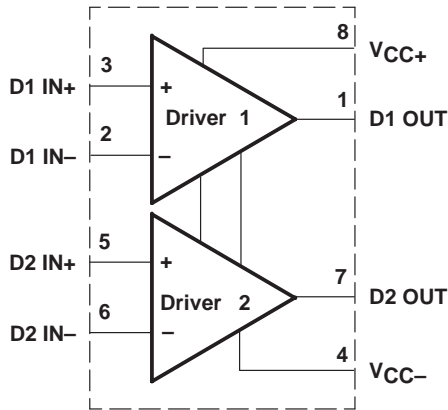

Figure 1. THS6042 – 8 Pin SOIC

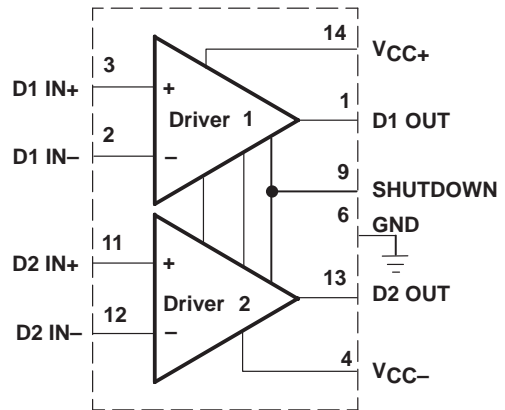

Figure 2. THS6043

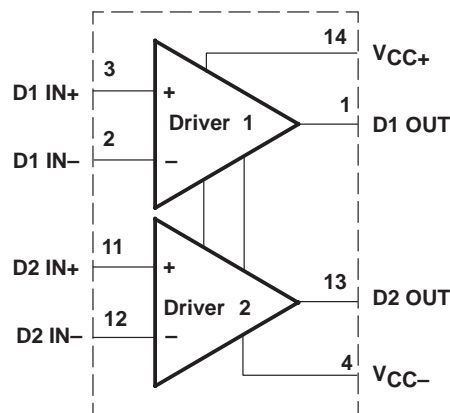

Figure 3. THS6042 – 14 Pin TSSOP

PRODUCT PREVIEW

absolute maximum ratings over operating free-air temperature (unless otherwise noted)†

Supply voltage, V_{CC+} to V_{CC-}	33 V
Input voltage	$\pm V_{CC}$
Output current (see Note 1)	400 mA
Differential input voltage	± 4 V
Maximum junction temperature	150°C
Total power dissipation at (or below) 25°C free-air temperature	See Dissipation Ratings Table
Operating free-air temperature, T_A : Commercial	0°C to 70°C
Industrial	-40°C to 85°C
Storage temperature, T_{stg} : Commercial	-65°C to 125°C
Industrial	-65°C to 125°C
Lead temperature 1,6 mm (1/16 inch) from case for 10 seconds	300°C

† Stresses beyond those listed under “absolute maximum ratings” may cause permanent damage to the device. These are stress ratings only, and functional operation of the device at these or any other conditions beyond those indicated under “recommended operating conditions” is not implied. Exposure to absolute-maximum-rated conditions for extended periods may affect device reliability.

NOTE 1: The THS6042 and THS6043 may incorporate a PowerPAD™ on the underside of the chip. This acts as a heatsink and must be connected to a thermally dissipating plane for proper power dissipation. Failure to do so may result in exceeding the maximum junction temperature which could permanently damage the device. See TI Technical Brief SLMA002 for more information about utilizing the PowerPAD™ thermally enhanced package.

DISSIPATION RATING TABLE

PACKAGE	θ_{JA}	$T_A = 25^\circ\text{C}$ POWER RATING
D-8	95°C/W‡	1.32 W
D-14	66.6°C/W‡	1.88 W
PWP	37.5°C/W	3.3 W

‡ This data was taken using the JEDEC proposed high-K test PCB. For the JEDEC low-K test PCB, the θ_{JA} is 168°C/W for the D-8 package and 122.3°C/W for the D-14 package.

recommended operating conditions

		MIN	NOM	MAX	UNIT
Supply voltage, V_{CC+} to V_{CC-}	Dual supply	± 2.5		± 15	V
	Single supply	5		30	
Operating free-air temperature, T_A	C-suffix	0		70	°C
	I-suffix	-40		85	

electrical characteristics over recommended operating free-air temperature range, $T_A = 25^\circ\text{C}$, $V_{CC+} = 12$ V, $V_{CC-} = \text{GND}$, $R_{\text{FEEDBACK}} = 750$ k Ω , $R_L = 25$ Ω (unless otherwise noted)

dynamic performance

PARAMETER		TEST CONDITIONS			MIN	TYP	MAX	UNIT
BW	Small-signal bandwidth (-3 dB) G=1	$V_{CC} = 12$ V, 0 V				80		MHz
		$V_{CC} = \pm 12$ V				125		
		$V_{CC} = \pm 15$ V				140		
SR	Slew rate (see Note 2)	$V_{CC} = 12$ V, 0 V				800		V/ μ s
		$V_{CC} = \pm 12$ V				1200		
		$V_{CC} = \pm 15$ V				1500		

NOTE 2: Slew rate is defined from the 25% to the 75% output levels.

THS6042, THS6043

200 mA REMOTE TERMINAL ADSL LINE DRIVERS

SLOS264A – MARCH 2000 – REVISED – MAY 2000

electrical characteristics over recommended operating free-air temperature range, $T_A = 25^\circ\text{C}$, $V_{CC+} = 12\text{ V}$, $V_{CC-} = \text{GND}$, $R_{\text{FEEDBACK}} = 750\text{ k}\Omega$, $R_L = 25\ \Omega$ (unless otherwise noted) (continued)

noise/distortion performance

PARAMETER		TEST CONDITIONS		MIN	TYP	MAX	UNIT
THD	Total harmonic distortion (single-ended configuration)	Gain = 4, $R_L = 100\ \Omega$, $V_{CC} = \pm 12\text{ V}$, $f = 250\text{ kHz}$	$V_{O(\text{pp})} = 2\text{ V}$		-85		dBc
			$V_{O(\text{pp})} = 16\text{ V}$		-75		
		Gain = 4, $R_L = 25\ \Omega$, $V_{CC} = 12\text{ V}$, 0 V , $f = 250\text{ kHz}$	$V_{O(\text{pp})} = 2\text{ V}$		-77		
			$V_{O(\text{pp})} = 8\text{ V}$		-76		
V_n	Input voltage noise	$V_{CC} = 12\text{ V}$, 0 V , $\pm 12\text{ V}$,	$f = 10\text{ kHz}$		2.1		$\text{nV}/\sqrt{\text{Hz}}$
I_n	Input current noise		$f = 10\text{ kHz}$	$V_{CC} = 12\text{ V}$, 0 V , $\pm 12\text{ V}$			$\text{pA}/\sqrt{\text{Hz}}$
					+Input	1.7	
	-Input				10.5		
X_T	Crosstalk	$f = 250\text{ kHz}$, $V_{CC} = \pm 12\text{ V}$, $G = 2$, $R_L = 100\ \Omega$	$V_O = 2\text{ Vp-p}$		-85		dBc
			$f = 250\text{ kHz}$, $V_{CC} = 12\text{ V}$, 0 V $G = 2$, $R_L = 25\ \Omega$	$V_O = 2\text{ Vp-p}$		-80	

dc performance

PARAMETER		TEST CONDITIONS		MIN	TYP	MAX	UNIT
V_{OS}	Input offset voltage	$V_{CC} = \pm 12\text{ V}$, 12 V , 0 V	$T_A = 25^\circ\text{C}$		2	15	mV
			$T_A = \text{full range}$			20	
	Differential offset voltage		$T_A = 25^\circ\text{C}$		2	15	
			$T_A = \text{full range}$			20	
Offset drift		$T_A = \text{full range}$			10	$\mu\text{V}/^\circ\text{C}$	
I_{IB}	- Input bias current	$V_{CC} = \pm 12\text{ V}$, 12 V , 0 V	$T_A = 25^\circ\text{C}$		2	9	μA
			$T_A = \text{full range}$			12	
	+ Input bias current		$T_A = 25^\circ\text{C}$		2	5	
			$T_A = \text{full range}$			6	
Differential input bias current	$T_A = 25^\circ\text{C}$		1.5	8			
	$T_A = \text{full range}$			11			
Z_{OL}	Open loop transimpedance	$R_L = 100\ \Omega$	$V_{CC} = \pm 12\text{ V}$, 12 V , 0 V		1		$\text{M}\Omega$

input characteristics

PARAMETER		TEST CONDITIONS		MIN	TYP	MAX	UNIT
V_{ICR}	Input common-mode voltage range	$V_{CC} = \pm 12\text{ V}$		± 10			V
		$V_{CC} = 12\text{ V}$, 0 V		2	to	10	
CMRR	Common-mode rejection ratio	$V_{CC} = \pm 12\text{ V}$, 12 V , 0 V	$T_A = \text{full range}$	65			dB
R_I	Input resistance	+ Input		1.5			$\text{M}\Omega$
		- Input		15			Ω
C_I	Input capacitance			2			pF

PRODUCT PREVIEW



THS6042, THS6043

200 mA REMOTE TERMINAL ADSL LINE DRIVERS

SLOS264A – MARCH 2000 – REVISED – MAY 2000

electrical characteristics over recommended operating free-air temperature range, $T_A = 25^\circ\text{C}$, $V_{CC+} = 12\text{ V}$, $V_{CC-} = \text{GND}$, $R_{\text{FEEDBACK}} = 750\text{ k}\Omega$, $R_L = 25\ \Omega$ (unless otherwise noted) (continued)

output characteristics

PARAMETER		TEST CONDITIONS		MIN	TYP	MAX	UNIT
V_O	Output voltage swing	Single ended	$R_L = 25\ \Omega$	$V_{CC} = \pm 12\text{ V}$	± 10	± 10.5	V
				$V_{CC} = 12\text{ V}, 0\text{ V}$	1.5 to 10.5	1.2 to 10.8	
		$R_L = 100\ \Omega$	$V_{CC} = \pm 12\text{ V}$	± 10.5	± 10.8		
			$V_{CC} = 12\text{ V}, 0\text{ V}$	1.4 to 10.6	1.1 to 10.9		
I_O	Output current	$R_L = 25\ \Omega$	$V_{CC} = \pm 12\text{ V}$	200	250	mA	
			$V_{CC} = 12\text{ V}, 0\text{ V}$	200	250		
I_{SC}	Short-circuit current	$R_L = 0\ \Omega$	$V_{CC} = 12\text{ V}, 0\text{ V}$	400		mA	
	Output resistance	Open loop		15		Ω	

power supply

PARAMETER		TEST CONDITIONS		MIN	TYP	MAX	UNIT
V_{CC}	Operating range	Dual supply		± 2		± 16.5	V
		Single supply		4		33	
I_{CC}	Quiescent current (each driver)	$V_{CC} = \pm 12\text{ V}$	$T_A = 25^\circ\text{C}$		7	8	mA
			$T_A = \text{full range}$			10	
		$V_{CC} = 12\text{ V}, 0\text{ V}$	$T_A = 25^\circ\text{C}$		6.5	7.5	
			$T_A = \text{full range}$			9.5	
PSRR	Power supply rejection ratio	$V_{CC} = \pm 12\text{ V}$	$T_A = 25^\circ\text{C}$		-68		dB
			$T_A = \text{full range}$		-65		
		$V_{CC} = 12\text{ V}, 0\text{ V}$	$T_A = 25^\circ\text{C}$		-69		
			$T_A = \text{full range}$		-66		

shutdown characteristics (THS6043 only)

PARAMETER		TEST CONDITIONS		MIN	TYP	MAX	UNIT
$V_{IL}(\text{SHDN})$	Shutdown pin voltage for power up	$V_{CC} = 12\text{ V}, 0\text{ V}$, (GND Pin as Reference)	$\text{GND} = 6\text{ V}$			0.8	V
$V_{IH}(\text{SHDN})$	Shutdown pin voltage for power down	$V_{CC} = 12\text{ V}, 0\text{ V}$, (GND Pin as Reference)	$\text{GND} = 6\text{ V}$	2			V
$I_{CC}(\text{SHDN})$	Total quiescent current when in shutdown state	$V_{\text{SHDN}} = 8\text{ V}$, $V_{CC} = 12\text{ V}, 0\text{ V}$	$V_{\text{GND}} = 6\text{ V}$,		0.3	0.7	mA
t_{DIS}	Disable time (see Note 3)	$V_{CC} = 12\text{ V}, 0\text{ V}$			0.2		μs
t_{EN}	Enable time (see Note 3)	$V_{CC} = 12\text{ V}, 0\text{ V}$			0.2		μs
$I_{IL}(\text{SHDN})$	Shutdown pin input bias current	$V_{\text{SHDN}} = 6\text{ V}$, $V_{CC} = 12\text{ V}, 0\text{ V}$	$V_{\text{GND}} = 6\text{ V}$,		70		μA

NOTE 3: Disable/enable time is defined as the time from when the shutdown signal is applied to the SHDN pin to when the supply current has reached half of its final value.

PRODUCT PREVIEW



THS6042, THS6043 200 mA REMOTE TERMINAL ADSL LINE DRIVERS

SLOS264A – MARCH 2000 – REVISED – MAY 2000

APPLICATION INFORMATION

PRODUCT PREVIEW

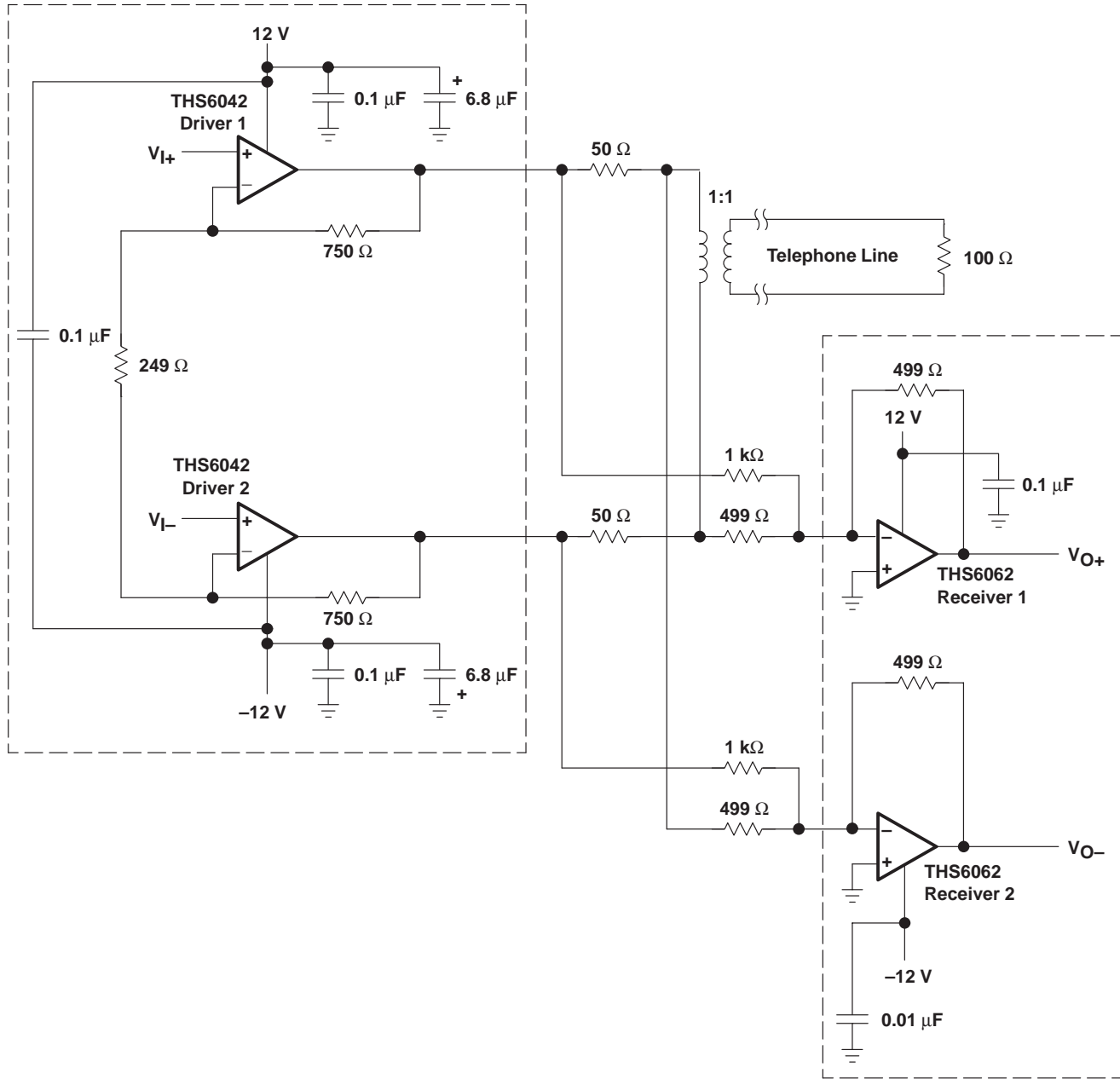

Figure 4. THS6042 ADSL Application With 1:1 Transformer Ratio

APPLICATION INFORMATION

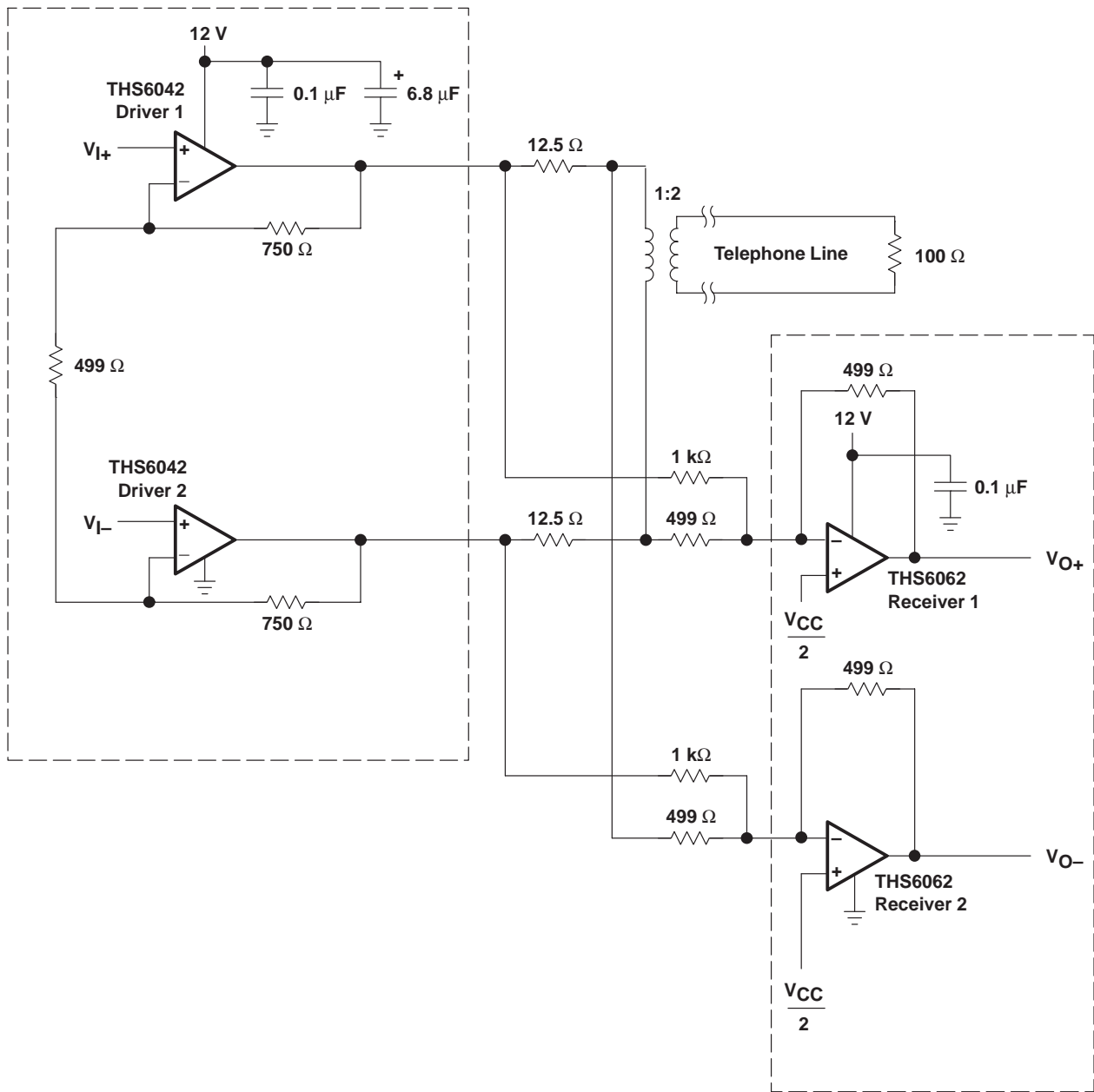

Figure 5. THS6042 ADSL Application With 1:2 Transformer Ratio

PRODUCT PREVIEW

THS6042, THS6043 200 mA REMOTE TERMINAL ADSL LINE DRIVERS

SLOS264A – MARCH 2000 – REVISED – MAY 2000

MECHANICAL DATA

D (R-PDSO-G**)

PLASTIC SMALL-OUTLINE PACKAGE

14 PINS SHOWN

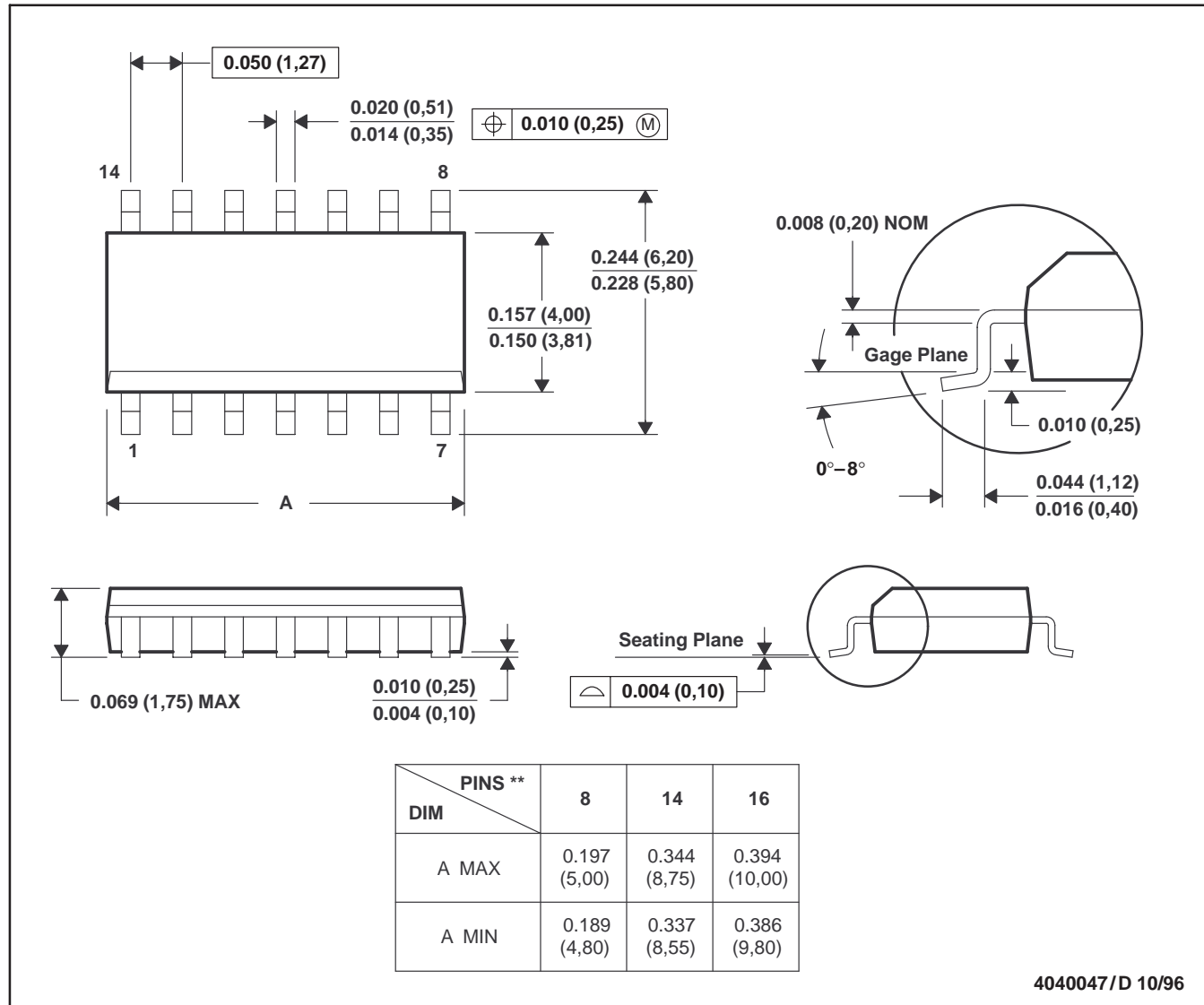

- NOTES: A. All linear dimensions are in inches (millimeters).
 B. This drawing is subject to change without notice.
 C. Body dimensions do not include mold flash or protrusion, not to exceed 0.006 (0,15).
 D. Falls within JEDEC MS-012

PRODUCT PREVIEW

MECHANICAL INFORMATION

PWP (R-PDSO-G**)

PowerPAD™ PLASTIC SMALL-OUTLINE PACKAGE

20-PIN SHOWN

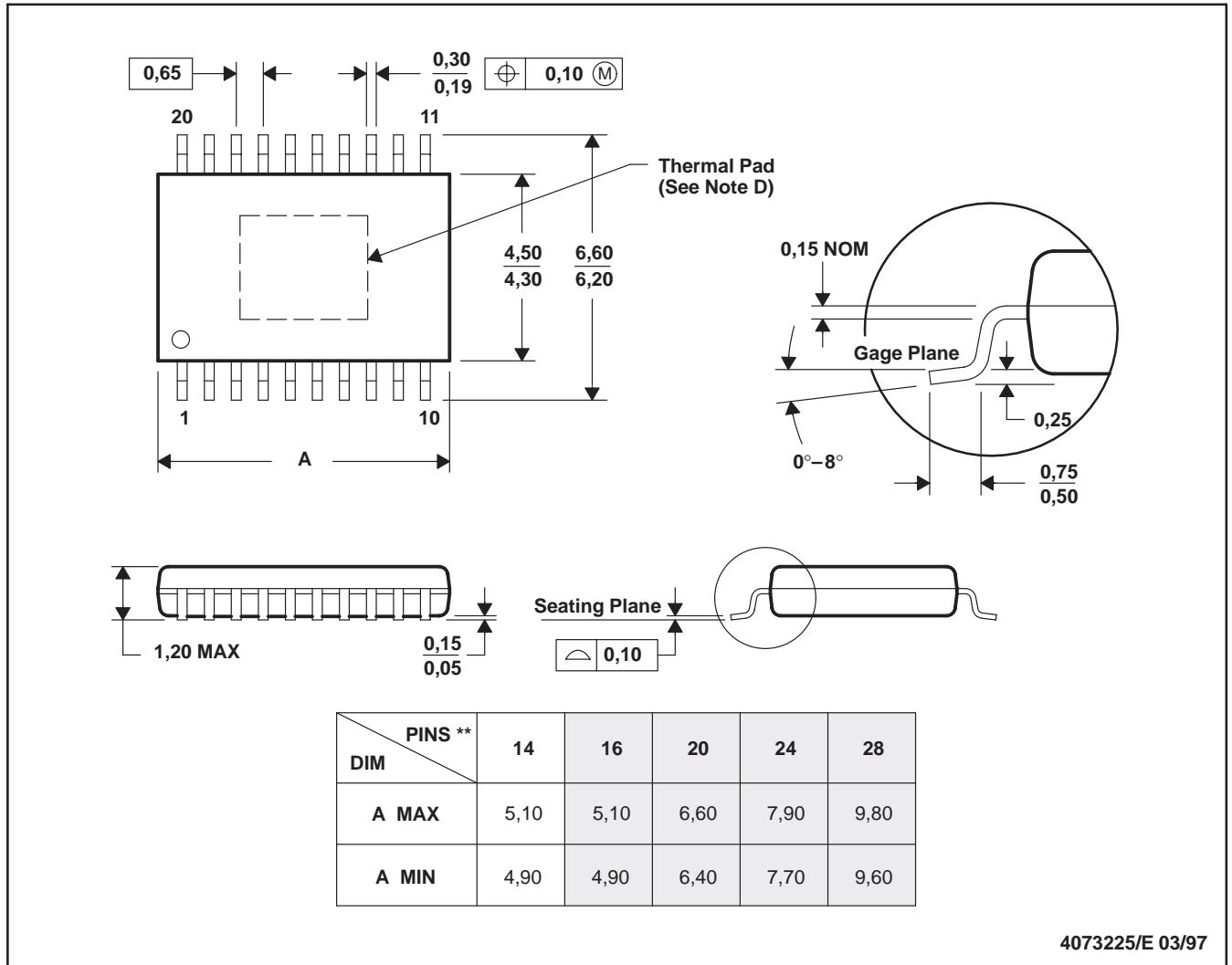

- NOTES: A. All linear dimensions are in millimeters.
 B. This drawing is subject to change without notice.
 C. Body dimensions do not include mold flash or protrusions.
 D. The package thermal performance may be enhanced by bonding the thermal pad to an external thermal plane. This pad is electrically and thermally connected to the backside of the die and possibly selected leads.
 E. Falls within JEDEC MO-153

PowerPAD is a trademark of Texas Instruments Incorporated.



IMPORTANT NOTICE

Texas Instruments and its subsidiaries (TI) reserve the right to make changes to their products or to discontinue any product or service without notice, and advise customers to obtain the latest version of relevant information to verify, before placing orders, that information being relied on is current and complete. All products are sold subject to the terms and conditions of sale supplied at the time of order acknowledgment, including those pertaining to warranty, patent infringement, and limitation of liability.

TI warrants performance of its semiconductor products to the specifications applicable at the time of sale in accordance with TI's standard warranty. Testing and other quality control techniques are utilized to the extent TI deems necessary to support this warranty. Specific testing of all parameters of each device is not necessarily performed, except those mandated by government requirements.

Customers are responsible for their applications using TI components.

In order to minimize risks associated with the customer's applications, adequate design and operating safeguards must be provided by the customer to minimize inherent or procedural hazards.

TI assumes no liability for applications assistance or customer product design. TI does not warrant or represent that any license, either express or implied, is granted under any patent right, copyright, mask work right, or other intellectual property right of TI covering or relating to any combination, machine, or process in which such semiconductor products or services might be or are used. TI's publication of information regarding any third party's products or services does not constitute TI's approval, warranty or endorsement thereof.