

DESCRIPTION The AA1F4M is designed for use in medium speed switching circuit.

FEATURE • Bias resistors built-in type NPN transistor equivalent circuit.

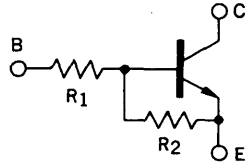

$R_1 = 22 \text{ k}\Omega$
 $R_2 = 22 \text{ k}\Omega$

ABSOLUTE MAXIMUM RATINGS

Maximum Temperatures	
Storage Temperature	-55 to +150 °C
Junction Temperature	150 °C Maximum
Maximum Power Dissipation ($T_a = 25 \text{ °C}$)	
Total Power Dissipation	300 mW
Maximum Voltages and Currents ($T_a = 25 \text{ °C}$)	
V_{CBO} Collector to Base Voltage	60 V
V_{CEO} Collector to Emitter Voltage	50 V
V_{EBO} Emitter to Base Voltage	10 V
$I_{C(DC)}$ Collector Current (DC)	100 mA
$I_{C(pulse)}$ Collector Current (pulse)	200 mA

PACKAGE DIMENSIONS in millimeters (inches)

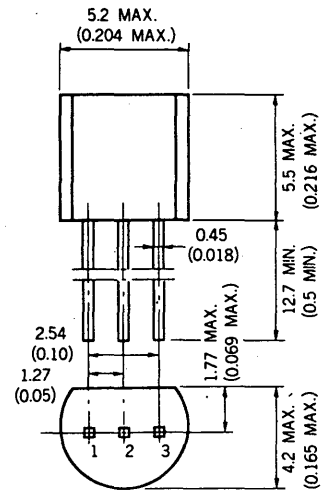

1. EMITTER EIAJ : SC-43B
2. COLLECTOR JEDEC : TO-92
3. BASE IEC : PA33

ELECTRICAL CHARACTERISTICS ($T_a = 25 \text{ °C}$)

SYMBOL	CHARACTERISTIC	MIN.	TYP.	MAX.	UNIT	TEST CONDITIONS
R_1	Input Resistance	15.4	22.0	28.6	$\text{k}\Omega$	
R_1/R_2	Resistors Ratio	0.9	1.0	1.1	—	
V_{IL}	Low Level Input Voltage		1.1	0.8	V	$V_{CE} = 5.0 \text{ V}, I_C = 100 \mu\text{A}$
V_{IH}	Hi Level Voltage	4.0	1.6		V	$V_{CE} = 0.2 \text{ V}, I_C = 5.0 \text{ mA}$
t_{on}	Turn on Time		0.11	0.4	μs	$V_{CC} = 5.0 \text{ V}, R_L = 1.0 \text{ k}\Omega$ $V_{in} = 5.0 \text{ V},$ $PW = 2 \mu\text{s}, \text{Duty Cycle} \leq 2 \%$
t_{stg}	Storage Time		2.3	5.0	μs	
t_{off}	Turn off Time		2.6	6.0	μs	
h_{FE1}	DC Current Gain	60	120	195	—	$V_{CE} = 5.0 \text{ V}, I_C = 5.0 \text{ mA}$
h_{FE2}	DC Current Gain	90	400		—	$V_{CE} = 5.0 \text{ V}, I_C = 50 \text{ mA}$
$V_{CE(sat)}$	Collector Saturation Voltage		0.04	0.2	V	$I_C = 5.0 \text{ mA}, I_B = 0.25 \text{ mA}$
I_{CBO}	Collector Cutoff Current			0.1	μA	$V_{CB} = 50 \text{ V}, I_E = 0$

TYPICAL CHARACTERISTICS ($T_a = 25^\circ\text{C}$)

