

MOS FET Relay

G3VM-601BY/EY

MOS FET Relay for Switching Analog Signals, with an I/O Dielectric Strength of 5 kVAC Using Optical Isolation

- Switches minute analog signals.
- Switches AC and DC.
- Load voltage: 600 V.
- I/O dielectric strength: 5 kVAC.
- UL/CSA approval pending.



■ Appearance

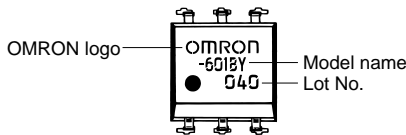

Note: "G3VM" is not printed on the actual product.

Ordering Information

Contact form	Terminals	Load voltage (peak value)	Model	Number per stick	Taping quantity
SPST-NO	PCB terminals	600 VAC	G3VM-601BY	50	---
	Surface-mounting terminals		G3VM-601EY		
			G3VM-601EY(TR)	---	

Application Examples

- Electronic automatic exchange systems
- Measuring systems
- FA
- Security systems

Specifications

■ Absolute Maximum Ratings (Ta = 25°C)

Item		Symbol	Rating	Conditions	
Input	LED forward current	I_F	50 mA	---	
	LED forward current reduction rate	$\Delta I_F/^\circ\text{C}$	-0.5 mA/°C	Ta ≥ 25°C	
	Repetitive peak LED forward current	I_{FP}	1 A	100- μs pulses, 100 pps	
	LED reverse voltage	V_R	5 V	---	
	Permissible loss	P_{in}	50 mW	---	
	Connection temperature	T_J	125°C	---	
Output	Output dielectric strength	V_{OFF}	600 V	AC peak value	
	Continuous load current	A connection	I_O	100 mA	---
		B connection		100 mA	---
		C connection		200 mA	---
	Peak load current	I_{pead}	0.3 A	---	
	Output loss	P_{out}	454 mW	---	
ON current reduction rate	A connection	$\Delta I_{ON}/^\circ\text{C}$	-1 mA/°C	Ta ≥ 25°C	
	B connection		-1 mA/°C		
	C connection		-2 mA/°C		
Total permissible loss		P_T	504 mW	---	
Dielectric strength between I/O terminals (See note.)		V_{I-O}	5,000 Vrms	AC, 1 min	
Insulation resistance		R_{I-O}	$5 \times 10^{10} \Omega$	$V_S = 500 \text{ V}$, ambient operating humidity ≤ 60%	
Storage temperature		T_{stg}	-55 to 125°C	---	
Ambient operating temperature		T_a	-40 to 85°C	---	

Note The dielectric strength between I/O terminals was measured with voltage applied to pins 1, 2, and 3 together, and to pins 4, 5, and 6 together.

Connection Circuit Diagram

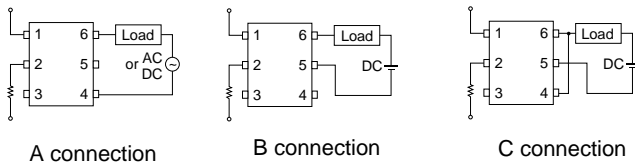

■ Electrical Performance (Ta = 25°C)

Item		Symbol	Minimum	Standard	Maximum	Conditions	
Input	LED forward current	V_F	1.0 V	1.15 V	1.3 V	$I_F = 10 \text{ mA}$	
	Reverse current	I_R	---	---	10 μA	$V_R = 5 \text{ V}$	
	Capacity between terminals	C_T	---	30 pF	---	$V = 0$, $f = 1 \text{ MHz}$	
Output	Maximum resistance with output ON	A connection	R_{ON}	---	22 Ω	35 Ω	$I_{ON} = 100 \text{ mA}$, $I_F = 10 \text{ mA}$
		B connection		---	17 Ω	27 Ω	$I_{ON} = 100 \text{ mA}$, $I_F = 10 \text{ mA}$
		C connection		---	8.5 Ω	13.5 Ω	$I_{ON} = 200 \text{ mA}$, $I_F = 10 \text{ mA}$
Current leakage when the relay is closed		I_{LEAK}	---	---	10 μA	$V_{OFF} = 600 \text{ V}$	
Turn-ON time		T_{ON}	---	0.5 ms	1.5 ms	$R_L = 200 \Omega$ (See note.)	
Turn-OFF time		T_{OFF}	---	0.1 ms	1.0 ms	$V_{DD} = 20 \text{ V}$, $I_F = 5 \text{ mA}$	
Floating capacity between I/O terminals		C_{I-O}	---	0.8 pF	---	$V_S = 0 \text{ V}$, $f = 1 \text{ MHz}$	

Note The operate and release time were measured in the way shown below.

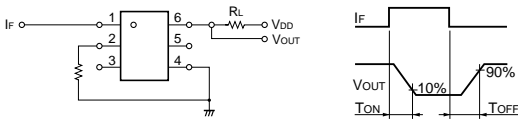

■ Recommended Operating Conditions

Item	Symbol	Minimum	Standard	Maximum
Operating voltage	V _{DD}	---	---	480 V
Forward current	I _F	5 mA	---	25 mA
Continuous load current	I _O	---	---	100 mA
Operating temperature	T _a	-20°C	---	65°C

Dimensions

Note All units are in millimeters unless otherwise indicated.

G3VM-601BY

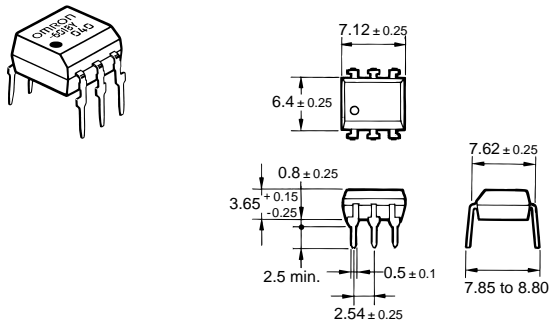

Weight: 0.4 g

G3VM-601EY

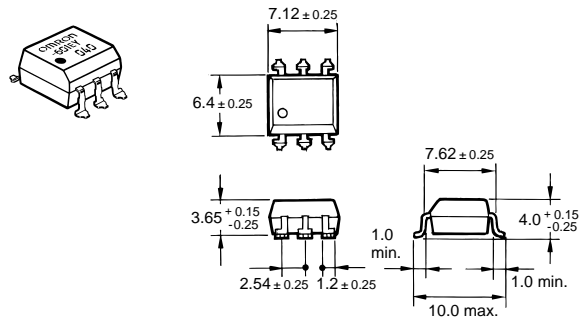

Weight: 0.4 g

Note: "G3VM" is not printed on the actual product.

■ PCB Dimensions (Bottom View)

G3VM-601BY

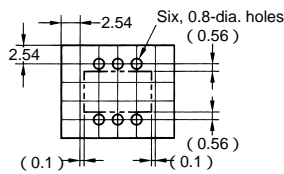

■ Actual Mounting Pad Dimensions (Recommended Value, Top View)

G3VM-601EY

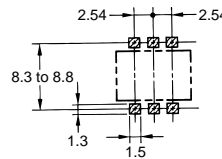

Installation

■ Terminal Arrangement/Internal Connection (Top View)

G3VM-601BY

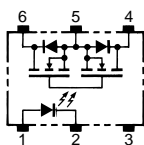

G3VM-601EY

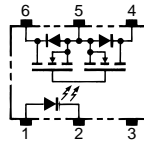

Precautions

! WARNING

Be sure to turn OFF the power when wiring the Relay, otherwise an electric shock may be received.

! WARNING

Do not touch the charged terminals of the SSR, otherwise an electric shock may be received.

! Caution

Do not apply overvoltage or overcurrent to the I/O circuits of the SSR, otherwise the SSR may malfunction or burn.

! Caution

Be sure to wire and solder the Relay under the proper soldering conditions, otherwise the Relay in operation may generate excessive heat and the Relay may burn.

Correct Use

Typical Relay Driving Circuit Examples

C-MOS

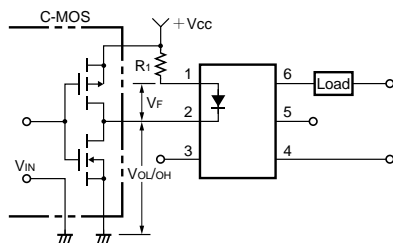

Transistor

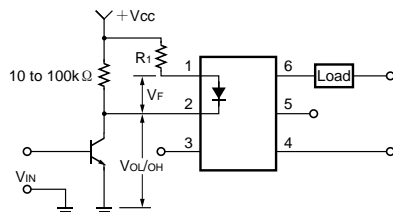

Use the following formula to obtain the LED current limiting resistance value to assure that the relay operates accurately.

$$R_1 = \frac{V_{CC} - V_{OL} - V_F(ON)}{5 \text{ to } 20 \text{ mA}}$$

Use the following formula to obtain the LED forward voltage value to assure that the relay releases accurately.

$$V_{F(OFF)} = V_{CC} - V_{OH} < 0.8 \text{ V}$$

Protection from Surge Voltage on the Input Terminals

If any reversed surge voltage is imposed on the input terminals, insert a diode in parallel to the input terminals as shown in the following circuit diagram and do not impose a reversed voltage value of 3 V or more.

Surge Voltage Protection Circuit Example

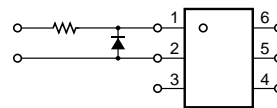

Protection from Spike Voltage on the Output Terminals

If a spike voltage exceeding the absolute maximum rated value is generated between the output terminals, insert a C-R snubber or clamping diode in parallel to the load as shown in the following circuit diagram to limit the spike voltage.

Spike Voltage Protection Circuit Example

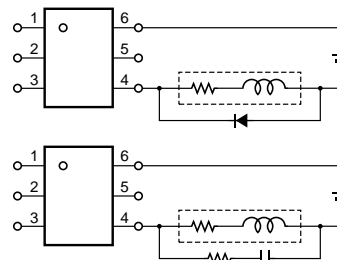

Unused Terminals (6-pin only)

Terminal 3 is connected to the internal circuit. Do not connect anything to terminal 3 externally.

Pin Strength for Automatic Mounting

In order to maintain the characteristics of the relay, the force imposed on any pin of the relay for automatic mounting must not exceed the following.

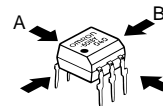

In direction A: 1.96 N max.
In direction B: 1.96 N max.

Load Connection

Do not short-circuit the input and output terminals while the relay is operating or the relay may malfunction.

AC Connection

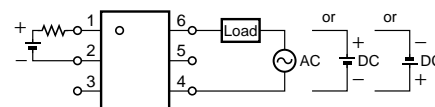

DC Single Connection

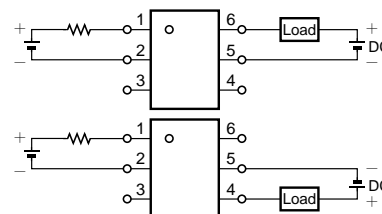

DC Parallel Connection

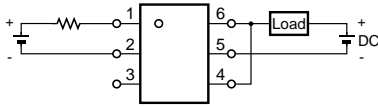

Solder Mounting

Maintain the following conditions during manual or reflow soldering of the relays in order to prevent the temperature of the relays from rising.

1. Pin Soldering
Solder each pin at a maximum temperature of 260°C within 10 s.
2. Reflow Soldering
 - a. Solder each pin at a maximum temperature of 260°C within 10 s.
 - b. Make sure that the ambient temperature on the surface of the resin casing is 240°C max. for 10 s maximum.
 - c. The following temperature changes are recommendable for soldering.

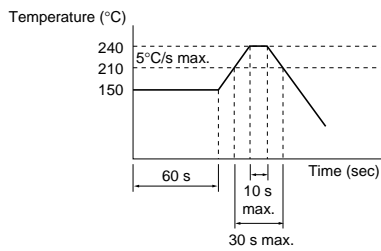

ALL DIMENSIONS SHOWN ARE IN MILLIMETERS.

To convert millimeters into inches, multiply by 0.03937. To convert grams into ounces, multiply by 0.03527.

Cat. No. K114-E1-1 **In the interest of product improvement, specifications are subject to change without notice.**

OMRON Corporation

Electronics Components Company

Electronic & Mechanical Components Division H.Q.
Low Signal Relay Division
2-1, 2-chome, Nishikusatsu, Kusatsu-city,
Shiga-pref., 525-0035 Japan

Phone: (81)77-565-5481 Fax: (81)77-565-5581

Printed in Japan
0201-2M (0201) (A)