



Power Management IC with Five Regulated Outputs Programmed Through 3-Wire Serial Interface

The MPC18730 Power Management IC (PMIC) regulates five independent output voltages from either a single cell Li-Ion (2.7 V to 4.2 V input range) or from a single cell Ni-MH or dry cell (0.9 V to 2.2 V input range).

The PMIC includes 2 DC-DC converters and 3 low drop out (LDO) linear regulators. The output voltage for each of the 5 output voltages is set independently through a 3-wire serial interface. The serial interface also configures the PMIC's versatile start-up control system, which includes multiple wakeup, sleep, standby, and reset modes to minimize power consumption for portable equipment.

In single cell Li-Ion applications two DC-DC converters are configured as buck (step-down) regulators. In single cell Ni-MH or dry cell applications, one DC-DC converter is configured as a boost (step-up) regulator, and the other as buck-boost regulator. The DC-DC converters' output voltages have set ranges 1.613 V to 3.2 V up to 120 mA, and 0.805 V to 1.5 V up to 100 mA.

Features

- Operates from single cell Li-Ion, Ni-MH, or Alkaline
- 2 DC-DC Converters
- 3 Low Drop Regulators
- Serial Interface Sets Output Voltages
- 4 Wake Inputs
- Low Current Standby Mode
- Pb-Free Packaging Designated by Suffix Code EP

18730

* POWER MANAGEMENT IC



ORDERING INFORMATION		
Device	Temperature Range (T _A)	Package
MPC18730EP/R2	-10°C to 65°C	64 QFN

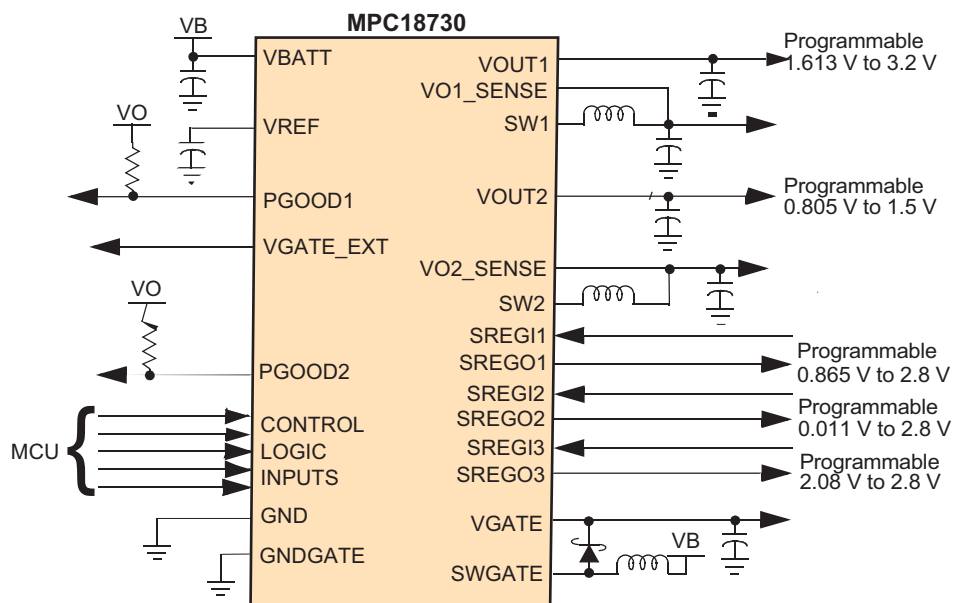

Figure 1. MPC18730 Simplified Application Diagram

* This document contains certain information on a new product. Specifications and information herein are subject to change without notice.

PIN CONNECTIONS

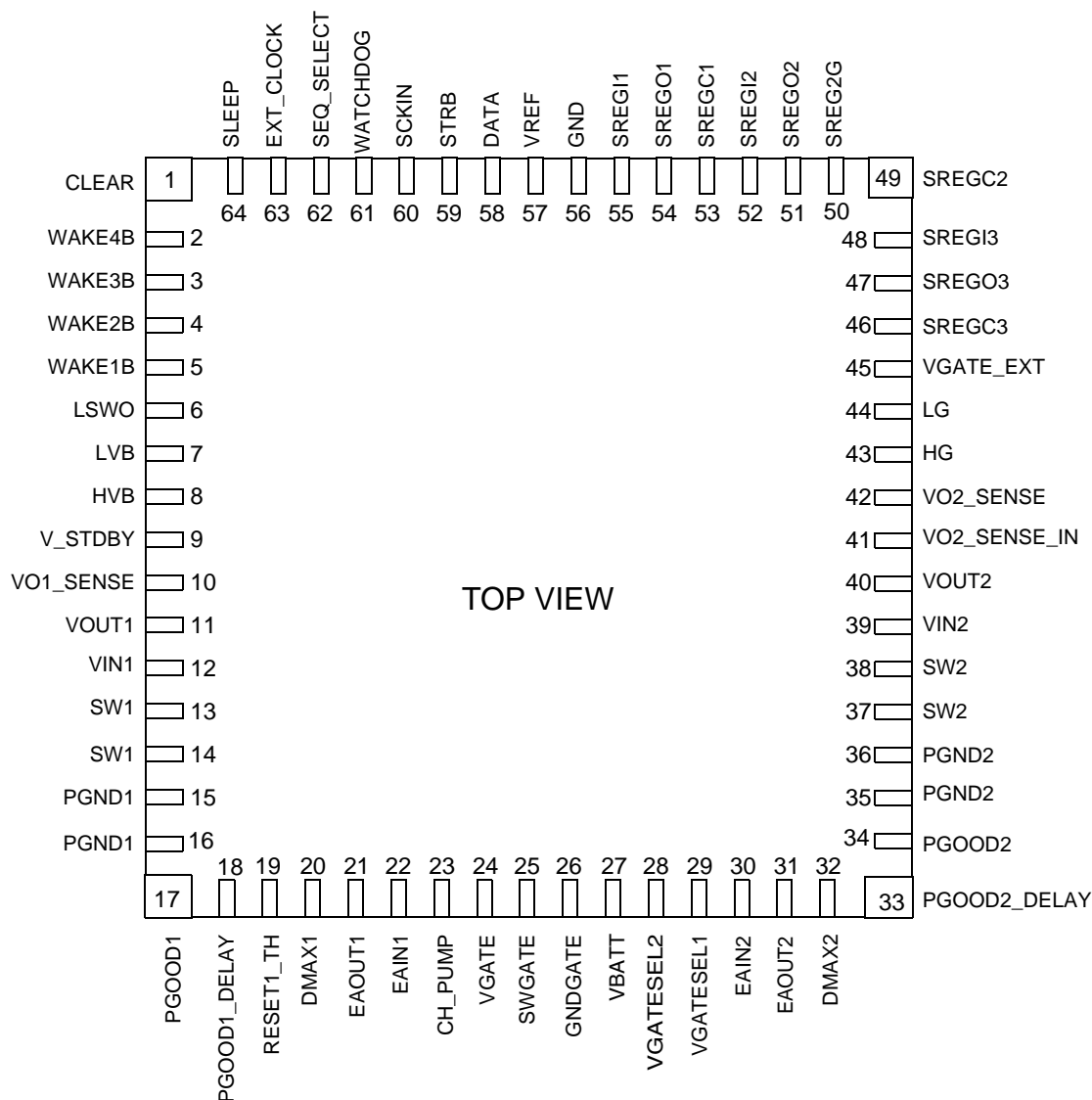

Figure 3. MPC18730 Pin Connections

Table 1. MPC18730 Pin Definitions

A functional description of each pin can be found in the Functional Pin Description section beginning on [page 14](#).

Pin Number	Pin Name	Pin Function	Formal Name	Definition
1	CLEAR	Input	Clear	Start-up Signal Input Latch/Clear
2	WAKE4B	Input	Wake Signal 4	Start-up Signal Input 4
3	WAKE3B	Input	Wake Signal 3	Start-up Signal Input 3
4	WAKE2B	Input	Wake Signal 2	Start-up Signal Input 2
5	WAKE1B	Input	Wake Signal 1	Start-up Signal Input 1
6	LSWO	Output	Low-Side Switch Output	Low-Side Switch Output Pin

Table 1. MPC18730 Pin Definitions (continued)

A functional description of each pin can be found in the Functional Pin Description section beginning on [page 14](#).

Pin Number	Pin Name	Pin Function	Formal Name	Definition
7	LVB	Input	Low Voltage Battery	VB Power Supply Connection for Ni_mh
8	HVB	Input	High Voltage Battery	VB Power Supply Connection for Li_ion
9	V_STDBY	Output	Standby Voltage	V_STDBY Voltage Output
10	VO1_SENSE	Input	Voltage Input 1	Switching Power Supply Circuit 1, VO1_SENSE Voltage Input, VO1_SENSE Power Supply
11	VOUT1	Output	Voltage Output 1	Power Switch 1 Output
12	VIN1	Output	Voltage Output 1	Switching Power Supply Circuit 1 Output
13	SW1	Power	Switching 1	Switching Power Supply Circuit 1 Coil Connection
14	SW1	Power	Switching 1	Switching Power Supply Circuit 1 Coil Connection
15	PGND1	Ground	Power Ground 1	Switching Power Supply Circuit 1 Power GND
16	PGND1	Ground	Power Ground 1	Switching Power Supply Circuit 1 Power GND
17	PGOOD1	Output	Inverted Reset Output 1	Reset Circuit 1 Reset Signal Output
18	PGOOD1_DELAY	Input	Reset Delay Capacitor 1	Reset Circuit 1 Reset Signal Delaying Capacitor Connection
19	RESET1_TH	Output	Reset1 Adjustment	Switching Power Supply Circuit 1 Reset Voltage Reference Output
20	DMAX1	Power	Duty Control	Switching Power Supply Circuit 1 Maximum Duty Setting
21	EAOUT1	Output	Reference Feedback 1	Switching Power Supply Circuit 1 Error Amp Output
22	EAIN1	Input	Input Minus 1	Switching Power Supply Circuit 1 Error Amp Inverse Input
23	CH_PUMP	Power	Charge Pump Capacitor	VGATE Power Supply Circuit Charge Pump Capacitor Connection
24	VGATE	Output	Gate Voltage	VGATE Power Supply Circuit Voltage Output, Pre-Diver Circuit Power Supply
25	SWGATE	Power	Switching	VGATE Power Supply Circuit Coil Connection
26	GNDGATE	Ground	Power Ground 3	VGATE Power Supply Circuit Power GND
27	VBATT	Power	Battery Voltage	VB Power Supply Connection
28	VGATESEL2	Output	VGATE Select 2	VG Power Supply Circuit Output Voltage Setting 2
29	VGATESEL1	Output	VGATE Select 1	VGATE Power Supply Circuit Output Voltage Setting 1
30	EAIN2	Input	Input Minus	Switching Power Supply Circuit 2 Error Amp Inverting Input
31	EAOUT2	Output	Reference Feedback 2	Switching Power Supply Circuit 2 Error Amp Output
32	DMAX2	Power	Duty Control	Switching Power Supply Circuit 2 Maximum Duty Setting
33	PGOOD2_DELAY	Input	Reset Delay Capacitor 1	Reset Circuit 2 Reset Signal Delay Capacitor Connection
34	PGOOD2	Output	Inverted Reset Output 2	Reset Circuit 2 Reset Signal Output
35	PGND2	Ground	Power Ground 2	Switching Power Supply Circuit 2 Power GND
36	PGND2	Ground	Power Ground 2	Switching Power Supply Circuit 2 Power GND

Table 1. MPC18730 Pin Definitions (continued)

A functional description of each pin can be found in the Functional Pin Description section beginning on [page 14](#).

Pin Number	Pin Name	Pin Function	Formal Name	Definition
37	SW2	Power	Switching	Switching Power Supply Circuit 2 Coil Connection
38	SW2	Power	Switching	Switching Power Supply Circuit 2 Coil Connection
39	VIN2	Output	Voltage Output	Switching Power Supply Circuit 2 Output
40	VOUT2	Output	Voltage Output	Power Switch 2 Output
41	VO2_SENSE_IN	Input	Voltage Input	Power Switch 2 Voltage Input
42	VO2_SENSE	Input	Voltage Input	Switching Power Supply Circuit 2 VO2_SENSE Voltage Input
43	HG	Output	Step Down Top FET 2	Switching Power Supply Circuit 2 Step down Top side FET Gate Output for Ni_mh
44	LG	Output	Step Down Bottom FET 2	Switching Power Supply Circuit 2 Step down Bottom side FRT Gate Output for Ni_mh
45	VGATE_EXT	Output	Gate Switch	External Transistor Gate Signal Output
46	SREGC3	Power	Regulator Capacitor 3	Series Pass Power Supply Circuit 3 External Feedback Connection
47	SREGO3	Output	Regulator Output 3	Series Pass Power Supply Circuit 3 Output
48	SREGI3	Power	Regulator Input 3	Series Pass Power Supply Circuit 3 Power Supply
49	SREGC2	Power	Regulator Capacitor 2	Series Pass Power Supply Circuit 2 External Feedback Connection
50	SREG2G	Output	Regulator Gate Output 2	Series Pass Power Supply Circuit 2 External Transistor Gate Signal Output
51	SREGO2	Output	Regulator Output 2	Series Pass Power Supply Circuit 2 Output
52	SREGI2	Power	Regulator Input 2	Series Pass Power Supply Circuit 2 Power Supply
53	SREGC1	Power	Regulator Capacitor 1	Series Pass Power Supply Circuit 1 External Feedback Connection
54	SREGO1	Output	Regulator Output 1	Series Pass Power Supply Circuit 1 Output
55	SREGI1	Power	Regulator Input 1	Series Pass Power Supply Circuit 1 Power Supply
56	GND	Ground	Ground	GND
57	VREF	Output	Reference Voltage	Reference Voltage Output
58	DATA	Input	Data Signal	Serial Interface Data Signal Input
59	STRB	Input	Strobe	Serial Interface Strobe Signal Input
60	SCKIN	Input	Serial Clock	Serial Interface Clock Signal Input
61	WATCHDOG	Input	Watch Dog Timer	Watchdog Timer Capacitor Connection
62	SEQ_SELECT	Input	Sequence Input	Start-Up Sequence Setting Input
63	EXT_CLOCK	Input	Clock Input	External Synchronous Clock Signal Input
64	SLEEP	Input	Sleep Signal	Sleep Signal Input

ELECTRICAL CHARACTERISTICS

MAXIMUM RATINGS

Table 2. Maximum Ratings

All voltages are with respect to ground unless otherwise noted. Exceeding these ratings may cause a malfunction or permanent damage to the device.

Ratings	Symbol	Value	Unit
ELECTRICAL RATINGS			
Power Supply Voltage	V_{BATT}	-0.5 to 5.0	V
Analog Signal Input ⁽¹⁾	V_{INAN}	-0.5 to $VO1+0.5$	V
Logic Signal Input WAKE1~4B CLEAR, SLEEP, EXT_CLOCK, SCKIN, DATA, STRB VGATESEL1,2	V_{ILRSTB} V_{ILGC} V_{ILGSEL}	-0.5 to $V_STDBY+0.5$ -0.5 to $VO1_SENSE+0.5$ -0.5 to $VBATT+0.5$	V
Output Power Current VOUT1 Power Supply Circuit ⁽²⁾ VOUT2 Power Supply Circuit SREG1 Power Supply Circuit SREG2 Power Supply Circuit SREG3 Power Supply Circuit VGATE Power Supply Circuit PGOOD1 Power Supply Circuit	I_{OVO1} I_{OVO2} I_{OREG1} I_{OREG2} I_{OREG3} I_{OVG} $I_{OPGOOD1}$	120 100 80 100 80 8 -20	mA
Open-Drain Output Apply Voltage PGOOD1 LSWO	V_{IODR} V_{IODV}	-0.5 to 3.3 -0.5 to 3.3	V
ESD Voltage ⁽³⁾ Human Body Model (HBM) Machine Model (MM) Charge Device Model (CDM)	V_{ESD1} V_{ESD2} V_{CDM}	± 1500 ± 200 ± 750	V
THERMAL RATINGS			
Operating Temperature Ambient Junction	T_A T_J	-10 to 65 150	$^{\circ}C$
Storage Temperature	T_{STG}	-50 to 150	$^{\circ}C$
Thermal Resistance ⁽⁴⁾ Junction to Ambient	$R_{\theta JA}$	69	$^{\circ}C/W$
Lead Soldering Temperature ⁽⁵⁾	T_{SOLDER}	260	$^{\circ}C$

Notes

1. VREF, DMAX1, DMAX2, SREGC1, SREGC2, SREGC3 and RESET1_TH.
2. Includes the series pass power supply circuit output current
3. ESD testing is performed in accordance with the Human Body Model (HBM) ($C_{ZAP} = 100$ pF, $R_{ZAP} = 1500$ Ω), the Machine Model (MM) ($C_{ZAP} = 200$ pF, $R_{ZAP} = 0$ Ω), and the Charge Device Model (CDM), Robotic ($C_{ZAP} = 4.0$ pF).
4. Device mounted on a 2s2p test board, in accordance with JEDEC JESD51-6 and JESD51-7.
5. Pin soldering temperature limit is for 10 seconds maximum duration. Not designed for immersion soldering. Exceeding these limits may cause malfunction or permanent damage to the device.

STATIC

Table 3. Static Electrical Characteristics

Characteristics noted under conditions VBATT = 1.2 V, VO1_SENSE = 2.4 V, VGATE = 6.0 V, f_{CLK} = 176.4 kHz unless otherwise noted. Typical values noted reflect the approximate parameter means at T_A = 27°C under nominal conditions unless otherwise noted.

Characteristic	Symbol	Min	Typ	Max	Unit
GENERAL					
VB Power Supply Voltage					V
Power Supply Voltage 1	V _{LVB}	0.9	1.2	2.2	
Power Supply Voltage 2	V _{HVB}	2.7	3.5	4.2	
Series Regulator Input Voltage ^{(6), (7)}	V _{SREGI}	V _{SREG} +0.2 ⁽⁸⁾	V _{SREG} +0.3	V _{SREG} +0.4	V
Start-Up Voltage	V _{BST}	0.9	-	-	V
Analog Signal Input ⁽⁹⁾	V _{IANA}	0	-	VO1_SENSE	V
Logic Signal Input					V
WAKE1-4B	V _{ILRSTB}	0	-	V_STDBY	
CLEAR, SLEEP, EXT_CLOCK, DATA, STRB and SCKIN	V _{ILGC}	0	-	VO1_SENSE	
VGATESEL1, 2	V _{ILGSEL}	0	-	VBATT	
Output Power Current					mA
VOUT1 Power Supply Circuit ⁽¹⁰⁾	I _{OVOUT1}	0	-	100	
VOUT2 Power Supply Circuit ⁽¹⁰⁾	I _{OVOUT2}	0	-	80	
SREG1 Power Supply Circuit	I _{OSREG1}	5.0	-	60	
SREG2 Power Supply Circuit	I _{OSREG2}	6.0	-	80	
SREG3 Power Supply Circuit	I _{OSREG3}	5.0	-	60	
VGATE Power Supply Circuit	I _{OVG}	-5.0	-	6.0	
PGOOD	I _{OPGOOD}	-	-	0	
Supply Current in Stand-by mode					μA
VB Supply Current (VB = 1.2 V for Ni_MH)	I _{BSNi}	-	5.0	10	
(HVB = 3.5 V for Li-Ion)	I _{BSLi}	-	8.0	12	
Supply Current in Operating mode					mA
VB Supply Current (VB = 1.2 V for Ni_MH)	I _{BNi}	-	9.0	18	
(HVB = 3.5 V for Li-Ion)	I _{BLi}	-	7.0	14	
Reference Power Supply Circuit					
Output Voltage	V _{REF}	1.255	1.275	1.295	V
Output Current	I _{OREF}	-0.3	-	0.3	mA
Switching Power Supply 1					V
VOUT1 Output Voltage (I _o = 0-100 mA)	V _{OUT1}	2.3	2.4	2.5	

Notes

- When applying voltage from an external source.
- 0.3 V when VGATE is 4.5 V.
- Provide 2 V or higher for the voltage difference (VGATE - VO1_SENSE).
- VREF, DMAX1, DMAX2, SREGC1, SREGC2, SREGC3 and RESET1_TH.
- Includes the series pass power supply circuit output current.

Table 3. Static Electrical Characteristics (continued)

Characteristics noted under conditions VBATT = 1.2 V, VO1_SENSE = 2.4 V, VGATE= 6.0 V, f_{CLK} = 176.4 kHz unless otherwise noted. Typical values noted reflect the approximate parameter means at T_A = 27°C under nominal conditions unless otherwise noted.

Characteristic	Symbol	Min	Typ	Max	Unit
Switching Power Supply 2					V
VOUT2 Output Voltage (I _o = 0~80 mA)	V _{OUT2}	1.05	1.15	1.25	
HG Output Voltage ⁽¹¹⁾ (I _{source} = 400 μA)	V _{DW2TH}	5.2	-	VGATE	
(I _{sink} = 400 μA)	V _{DW2TL}	0	-	0.3	
LG Output Voltage ⁽¹¹⁾ (I _{source} = 400 μA)	V _{DW2BH}	5.2	-	VGATE	
(I _{sink} = 400 μA)	V _{DW2BL}	0	-	0.3	
Series Pass Power Supply Circuit					
SREG1 Control Voltage (I _o = 5~60 mA) ⁽¹²⁾	V _{SREG1}	2.7	2.8	2.9	V
SREG1-Error AMP Input offset voltage ⁽¹³⁾	SR1OFST	-13.5	-	24.5	mV
SREG2 Control Voltage (I _o = 6~80 mA) ⁽¹²⁾	V _{SREG2}	2.7	2.8	2.9	V
SREG2-Error AMP Input offset voltage ⁽¹⁴⁾	SR2OFST	-17	-	17	mV
SREG3 Control Voltage (I _o = 5~60 mA) ⁽¹²⁾	V _{SREG3}	2.7	2.8	2.9	V
SREG3-Error AMP Input offset voltage ⁽¹⁵⁾	SR3OFST	-11	-	23	mV
SREG2G Output Voltage ⁽¹⁶⁾ (I _{source} = 2.5 μA)	SREG2GH	5.0	-	VGATE	V
(I _{sink} = 2.5 μA)	SREG2GL	0	-	0.5	V
Power Switch On Resistance					W
VOUT1 Circuit	R _{VOUT1}	-	0.4	0.6	
VOUT2 Circuit	R _{VOUT2}	-	0.4	0.6	
VGATE Power Supply Circuit					V
(I _o = 0~6 mA) ⁽¹⁷⁾	V _{GATE_00}	5.5	6.0	6.5	
(I _o = 0~6 mA) ⁽¹⁸⁾	V _{GATE_10}	4.6	5.0	5.4	
CH_PUMP Output Voltage (I _{source} = 2.5 mA)	V _{O1_SENSE1LH}	VB x 0.85	-	VB	
(I _{sink} = 2.5 mA)	V _{O1_SENSE_1LL}	0	-	0.4	
VGH Voltage (Certified value)	V _{GH}	-	-	10.5	
V_STDBY Output Voltage for Li_ion (I _o = 300 μA) ⁽¹⁹⁾	V _{LVB}	1.75	-	2.45	V

Notes

- Connect a transistor with gate capacity of 200 pF or smaller to HG and LG
- If a capacitor with capacitance of 22 μF is connected to SREGO, use a phase compensation capacitor between SREGO and SREGC when the load is 5 mA (6 mA for SREG2) or lower. The output voltage values shown in the table assume that external resistance is connected as follows:
 SREGI1 = 3.0 V to 3.3 V, 65.14KΩ between SREGO1 and SREGC1, 34.86KΩ between SREGC1 and GND.
 SREGI2 = 3.0 V to 3.3 V, 54.46KΩ between SREGO2 and SREGC2, 45.54KΩ between SREGC2 and GND.
 SREGI3 = 3.0 V to 3.3 V, 73.84KΩ between SREGO3 and SREGC3, 26.16KΩ between SREGC3 and GND.
- Calculated by the right formula for input offset: SR1OFST = (V_{ref} x 0.77) - (SREGO1 ÷ (100k ÷ 34.86k))
- Calculated by the right formula for input offset: SR2OFST = (V_{ref} x 1) - (SREGO1 ÷ (100k ÷ 45.54k))
- Calculated by the right formula for input offset: SR3OFST = (V_{ref} x 0.58) - (SREGO1 ÷ (100k ÷ 26.16k))
- Connect a transistor with gate capacity of 300 pF or smaller to REG2G.
- When VGATESEL1 is Low and VGATESEL2 is Low, I/O = 3 mA or higher is certified by specification.
- When VGATESEL1 is High and VGATESEL2 is Low, I/O = 3 mA or higher is certified by specification.
- When HVB is 4.2 V and the load from V_STDBY is 0.5 μA or higher.

Table 3. Static Electrical Characteristics (continued)

Characteristics noted under conditions VBATT = 1.2 V, VO1_SENSE = 2.4 V, VGATE = 6.0 V, f_{CLK} = 176.4 kHz unless otherwise noted. Typical values noted reflect the approximate parameter means at T_A = 27°C under nominal conditions unless otherwise noted.

Characteristic	Symbol	Min	Typ	Max	Unit
Reset Circuit					
Reset Voltage 1	V _{RST1}	0.85 x VO1_SENSE	0.88 x VO1_SENSE	0.91 x VO1_SENSE	V
Reset Voltage 2	V _{RST2}	0.80 x VO1_SENSE	0.85 x VO1_SENSE	0.90 x VO1_SENSE	V
Hysteresis Voltage 1 (@RST1)	V _{HYRS1}	40	78	115	mV
Hysteresis Voltage 2 (@RST2)	V _{HYRS2}	50	75	100	mV
PGOOD (V _{PGOOD} = 2.4 V)	I _{PGOOD1,2}	0	-	10	μA
(I _{sink} = 2 mA)	V _{PGOOD1,2}	0	-	0.5	V
PGOOD_DELAY (I _{sink} = 100 μA)	V _{OLCR1,2}	0	-	0.7	V
High Level Threshold Voltage	V _{IHCR1,2}	1.25	1.42	1.65	V
Low Level Threshold Voltage	V _{ILCR1,2}	0.75	1.00	1.15	V
PGOOD_DELAY Pull-Up Resistance	R _{PUPRC1,2}	50	100	150	KΩ
V_STDBY Output Resistance					W
Output Resistance (VO1_SENSE)	R _{VO1_SENSE}	-	30	45	
Output Resistance (VBATT)	R _{VB}	-	200	400	
LSWO Output Resistance					W
Output Resistance	R _{LSWO}	-	42	50	
VGATE_EXT					V
VGATE_EXT Output Voltage (I _{source} = 100 μA)	V _{OHEXTG}	VGATE x 0.9	-	VGATE	
(I _{sink} = 100 μA)	V _{OLEXTG}	0	-	VGATE x 0.1	
Logic Input					
"H" Level Input Voltage ⁽²⁰⁾	V _{IHVS}	V_STDBY - 0.2	-	-	V
"L" Level Input Voltage ⁽²⁰⁾	V _{ILVS}	-	-	0.2	V
"H" Level Input Voltage ⁽²¹⁾	V _{IH}	1.5	-	-	V
"L" Level Input Voltage ⁽²¹⁾	V _{IL}	-	-	0.4	V
"H" Level Input Voltage ⁽²²⁾	V _{IHVB}	VB - 0.2	-	-	V
"L" Level Input Voltage ⁽²²⁾	V _{ILVB}	-	-	0.2	V
"H" Level Input Current ^{(20), (22)}	I _{IH}	-1.0	-	1.0	μA
"L" Level Input Current ^{(22), (23)}	I _{IL}	-1.0	-	1.0	μA
Pull Up Resistance ⁽²⁴⁾	R _{PUP}	410	590	770	KΩ
Pull Down Resistance ⁽²⁵⁾	R _{PDW}	330	480	625	KΩ

Notes

20. Applied to WAKEB1 ~ 4 and SEQ_SELECT.
21. Applied to CLEAR, SLEEP, EXT_CLOCK, DATA, STRB and SCKIN.
22. Applied to VGATESEL1 and 2.
23. Applied to WAKEB1 ~ 3, CLEAR, SLEEP, EXT_CLOCK, DATA, STRB, SCKIN and SEQ_SELECT.
24. Applied to WAKEB4.
25. Applied to CLEAR, SLEEP, EXT_CLOCK, DATA, STRB and SCKIN.

DYNAMIC

Table 4. Dynamic Electrical Characteristics

Characteristics noted under conditions VBATT = 1.2 V, VO1_SENSE = 2.4 V, VGATE = 6.0 V, f_{CLK} = 176.4 kHz unless otherwise noted. Typical values noted reflect the approximate parameter means at T_A = 27°C under nominal conditions unless otherwise noted.

Characteristic	Symbol	Min	Typ	Max	Unit
OSCILLATOR					
Internal Oscillation Frequency	f _{ICK}	150	200	250	kHz
MICRO CONTROLLER INTERFACE					
Clock Signal Input ⁽²⁶⁾	f _{CLK}	-	176.4	-	kHz
Serial Interface (Refer to Figure 5. Serial Interface Timing Diagrams)					
DATA Set Up Time	t _s	20	-	-	nsec
DATA Hold Time	t _h	20	-	-	nsec
SCKIN Clock Frequency	f _{sck}	-	6.0	-	MHz
SCKIN 'H' Pulse Width	t _{wckh}	50	-	-	nsec
SCKIN 'L' Pulse Width	t _{wckl}	50	-	-	nsec
SCKIN Hold Time	t _{hck}	50	-	-	nsec
STRB Set Up Time	t _{ssb}	50	-	-	nsec
STRB Pulse Width	t _{wsb}	50	-	-	nsec

Notes

26. Duty 50%.

TIMING DIAGRAMS

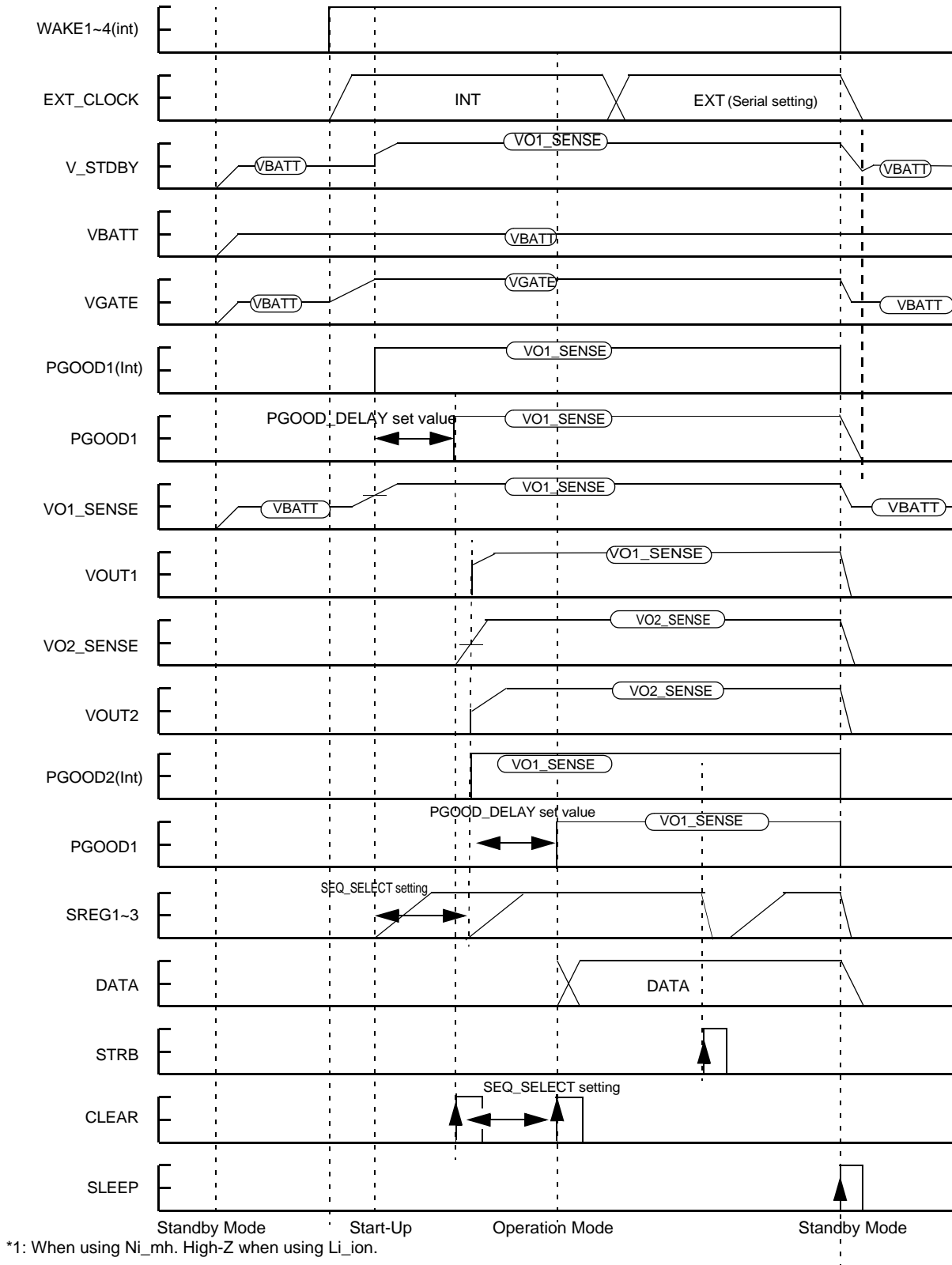

Figure 4. Power Supply Start-Up Timing Diagram

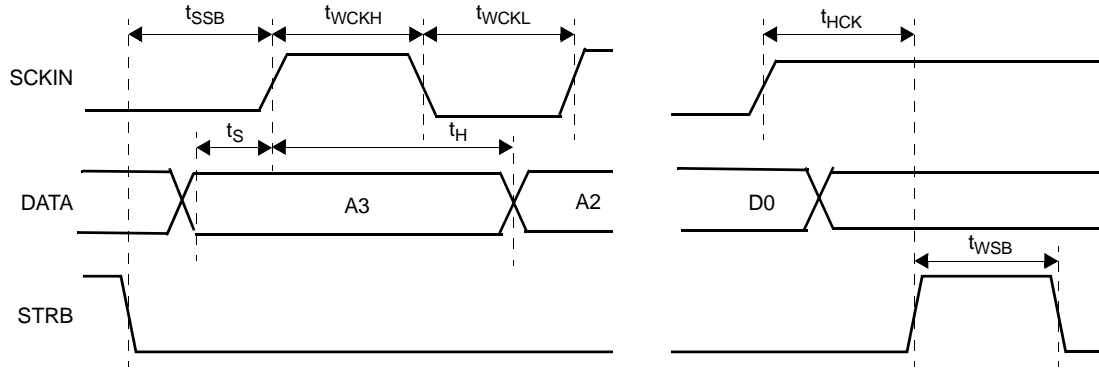

Figure 5. Serial Interface Timing Diagrams

Table 5. Serial Interface Functions

Register Name	Address	DATA1				DATA2			
0 CLEAR, SLEEP	1000	CLEAR	SLEEP	Reserved	Reserved	Reserved	Reserved	Reserved	Reserved
1 Power Mode	0001	PSW1	PSW2	PGOOD1	VOUT2	SREG1	SREG2	SREG3	PGOOD2
2 Clock Select	0010	Ext / Int	Half Freq	RSTB sleep	S_Off_VGATE	VG_Duty[3]	VG_Duty[2]	VG_Duty[1]	VG_Duty[0]
3 VO1_SENSE	0011	MSB	VO1_SENSE Output Voltage				LSB	S_Off_VO1_SENSE	
4 VO2_SENSE	0100	MSB	VO2_SENSE Output Voltage				LSB	S_Off_VO2_SENSE	
5 SREG1	0101	MSB	SREG1 Output Voltage				LSB	Reserved	
6 SREG2	0110	MSB	SREG2 Output Voltage				LSB		
7 SREG3	0111	MSB	SREG3 Output Voltage				LSB	CP Off	EXTG On

Twelve bits immediately before start-up of STRB are always effective. Upon power on, the internal power on reset works to initialize the registers. Serial data is fetched in the

order of Add_[3], Add_[2], ..., Add_[0], DATA1_[3], DATA1_[2], ..., DATA2_[0].

Table 6. Block Operation

INPUT					OUTPUT				
WAKE (Int)	PGOOD1 (Int)	PGOOD1	PGOOD2(Int)	SEQ_SELECT	VGATE	VO1_SENSE	VO2_SENSE	VOUT1,2	REG 1,2,3
L	X	X	X	X	-	-	-	-	-
H	L	L	L	L	O	O	-	-	-
H	H	L	L	L	O	O	-	-	O
H	H	L	L	H	O	O	-	-	-
H	H	H	H	L	O	O	O	O	O
H	H	H	H	H	O	O	O	O	O

O : Operation, - : Stop, X : Don't care

Table 7. Start-Up Sequence Settings

SEQ_SELE CT	CLEAR/ SLEEP	Series Regulators
V_STDBY	PGOOD2(Ext)	PGOOD2(Int)
GND	PGOOD1(Ext)	PGOOD1(Int)

FUNCTIONAL DESCRIPTION

INTRODUCTION

The 18730 power management integrated circuit provides five independent output voltages for the micro controller from either a single cell Li-Ion or from a single cell Ni-MH or dry cell. The PMIC includes two DC to DC converters and three low drop out linear regulators. The output voltage for each of the five output voltages is set independently through a 3-wire serial interface. The PMIC has multiple wakeup, sleep, and

reset modes to minimize power consumption for portable equipment. In single cell Li-Ion applications two DC-DC converters are configured as buck regulators. In single cell Ni-MH or dry cell applications, one DC-DC converter is configured as a boost regulator, and the other as buck-boost regulator.

FUNCTIONAL PIN DESCRIPTION

CLEAR PIN (CLEAR)

This Clear input signal makes clear internal latches for WAKE signal holding. The WAKE control circuit can not receive another WAKE input until the latch is cleared by this Clear input.

WAKE SIGNAL PINS (WAKE1B, WAKE2B, WAKE3B, WAKE4B) ... ACTIVE LOW

Any one WAKE input signal of these four WAKE inputs awakes this device from sleep mode. The WAKE signals can be made with external low side mechanical switch and resistance that is pulled up to VSTB rail.

LOW-SIDE SWITCH OUTPUT PIN (LSWO)

Low-Side switch output that is turned on with 'CLEAR' signal. It can be used for external key input latches clear.

LOW VOLTAGE BATTERY PIN (LVB)

This input pin is used for temporarily power supply while wake up for 1cell Ni-MH battery or 1 cell dry cell battery (= Low Voltage Battery) use. It has to be connected to VB rail. When Li-Ion battery is used, the pin has to be open.

HIGH VOLTAGE BATTERY PIN (HVB)

This input pin is used for temporarily power supply while wake up for Li-Ion battery (= High Voltage Battery) use. It has to be connected to the VB rail. When a Ni-MH battery is used, the pin has to be connected to ground level.

STANDBY VOLTAGE PIN (V_STDBY)

Standby Voltage is made from LVB or HVB that depends on which battery is used. This voltage is used for internal logic and analog circuit at standby (sleep) mode temporarily before 'VO1_SENSE' voltage is established.

VOLTAGE INPUT PINS (VO1_SENSE, VO2_SENSE)

This power supply input pin named 'VO1_SENS or VO2_SENSE' is for internal logic and analog circuits and for input of 'VOUT1' output via power switch. Input for 'VOUT2' is 'VO2_SENSE_IN' pin. It is supplied from the output of

Channel-1 or Channel-2 DC/DC converter as 'VO1_SENSE or VO2_SENSE'.

VOLTAGE OUTPUT PINS (VOUT1, VOUT2)

Output 'VO1_SENSE or 'VO2_SENSE' voltage controlled internal power switch.

POWER INPUT PINS (VIN1, VIN2)

The power input pins (VIN1, VIN2) are drain pins on the top side FET of the DC/DC converter switcher. They are the power input for the buck converter and output for the boost converter.

SWITCHING PINS (SW1, SW2)

Switching Pins (SW1, SW2) are the output of the half bridge and connect to the external inductance.

POWER GROUND PINS (PGND1, PGND2, GNDGATE)

Ground level node for DC/DC converter and Charge Pump portion.

INVERTED RESET OUTPUT PINS (PGOOD1, PGOOD2)

Reset signal output for external MPU or the something controller. PGOOD1 keeps 'Low' level while the VO1_SENSE voltage is less than internal reference voltage. PGOOD2 follows to VO2_SENSE voltage.

RESET DELAY CAPACITOR PINS (PGOOD1_DELAY, PGOOD2_DELAY)

The capacitor connected to this pin decides delay time to negate the Reset signal from exceeding the reference voltage level.

RESET 1 ADJUSTMENT PIN (RESET1_TH)

Used to adjust the reset level with external resistance which is connected to VO1_SENSE for PGOOD1.

DUTY CONTROL PINS (DMAX1, DMAX2)

Connected external voltage to this pin via capacitance can control the duty of DC/DC converter switching. Use of the pin for this is not recommended.

REFERENCE FEEDBACK PINS (EAOUT1, EAOUT2)

Output node of internal error amp. for DC/DC converter 1 and 2. Used for phase compensation.

INPUT MINUS PINS (EAIN1, EAIN2)

Minus input of internal error amp. for DC/DC converter 1 and 2. Used for phase compensation.

CHARGE PUMP CAPACITOR PIN (CH_PUMP)

In case of use higher voltage than VGATE externally, connect capacitance and diodes between VGATE. The charge pump structure can output $VGATE + V_B - 2 \times V_F$ voltage. There is no meaning for Ni-MH or dry cell battery, because the V_B voltage is almost same as $2 \times V_F$ voltage. Recommend to use for Li-Ion battery use.

GATE VOLTAGE PIN (VGATE)

Output pin of boost converter for gate drive voltage. The output voltage is decided by VGSEL input.

SWITCHING FOR GATE VOLTAGE PIN (SWGATE)

Switching pin for VGATE boost converter. Connect to external inductance.

BATTERY VOLTAGE PIN (VBATT)

Power supply input that connects to Ni-MH or Dry cell or Li-Ion battery.

VGATE SELECT PINS (VGATESEL1, VGATESEL2)

VGATE output voltage is decided with these two bits input.

VOLTAGE INPUT FOR POWER SWITCH 2 PIN (VO2_SENSE_IN)

Input of VOUT2 output via power switch. Connect to VO2_SENSE pin externally.

STEP DOWN FET GATE DRIVE PINS (HG, LG)

Gate drive output pins for external FETs to use DC/DC converter 2 as Buck / Boost converter.

GATE SWITCH PIN (VGATE_EXT)

Gate drive output pin for external low side switch. It can be used for power switch turning On/OFF for remote controller part.

REGULATOR CONTROL PINS (SREGC1, SREGC2, SREGC3)

Feed back pin for each series regulators. This pin voltage is compared with internal reference voltage. Input the feed back voltage that divided SREGO voltage by resistances.

REGULATOR OUTPUT PINS (SREGO1, SREGO2, SREGO3)

Series regulator output pins. All output voltages can be variable with internal DAC via serial I/F.

REGULATOR INPUT PINS (SREGI1, SREGI2, SREGI3)

Series regulator power input pins. To be connected to battery voltage in general.

GROUND PIN (GND)

Ground pin for logic and analog circuit portion (not power portion). Recommend to connect to clean ground which separated with power ground line.

REFERENCE VOLTAGE PIN (VREF)

Output of internal reference voltage. It can be used externally. Output current capacity is less than 300 μ A.

DATA INPUT PIN (DATA)

Serial data input pin for the serial interface. The last 12 bits received before the strobe signal's low to high transition are latched.

STROBE PIN (STRB)

Strobe signal input pin for serial interface. It latches the 12 bits of data input to the internal control registers.

SERIAL CLOCK PIN (SCKIN)

Clock input pin for serial interface. Input data are taken in to I/F with this clock.

WATCH DOG TIMER PIN (WATCHDOG)

Watch dog timer prevent unstable wake up (flips between wake-up and failure). If there is no 'CLEAR' input after any WAKEnB input before this WATCHDOG is expired, this device moves to 'SLEEP' mode to prevent wake failure hanging-up situation.

SEQUENCE SELECT PIN (SEQ_SELECT)

Select judgement Reset channel for wake-up complete with this input. If this input level is V_STDBY voltage, this device judges the wake-up completion with Reset2 (DC/DC2). If it is Ground, judge with Reset1 (DC/DC1). See [Table 7, on page 13](#).

CLOCK INPUT PIN (EXT_CLOCK)

Clock input pin for internal switching part. This device has a oscillator internally, but can use this input clock for internal switching frequency. It is selected by Clock select bit. See [Table 19. on page 25.](#)

SLEEP MODE PIN (SLEEP)

The sleep input signal puts the device in sleep mode. All output voltages are down, and internal current consumption will be minimum.

FUNCTIONAL DEVICE OPERATION

OPERATIONAL MODES

START-UP CONTROL INPUT (SYSTEM CONTROL)

The latch is set at the rising edge of any WAKE1B-4B input pin, and WAKE(int) goes High. WAKE1~4B inputs consist of OR logic. At this time, the input pin which went Low keeps latched until CLEAR goes High. After the latch is reset by CLEAR, WAKE(int) goes Low when SLEEP goes High. The latch is also cleared and WAKE(int) goes Low when SLEEP goes High before the latch is cleared by CLEAR. In this case, CLEAR keeps negated while PGOOD1, 2(Ext) is Low. SLEEP keeps negated while PGOOD1, 2(Ext) is Low or CLEAR is High. The period of time for which CLEAR and SLEEP are negated can be set by the SEQ_SELECT pin. Refer to Truth [Table 5, on page 12](#) for the correspondence between the SEQ_SELECT pin settings and negation period.

If SLEEP goes High to place the chip into the standby mode while any of the WAKEB pins is Low, the chip can be awakened again. This may happen if, when an WAKEB pin and LSWO are connected, SLEEP goes High earlier than the period of time (*1) specified by the external component of the WAKEB pin.

Also, if the period of time after WAKE(int) goes High until CLEAR goes High from Low is longer than the time specified by WATCHDOG, internal sleep will start up to place the chip into the standby mode.

(*1: It is 30 μ sec when a capacitor is not connected as the external component.)

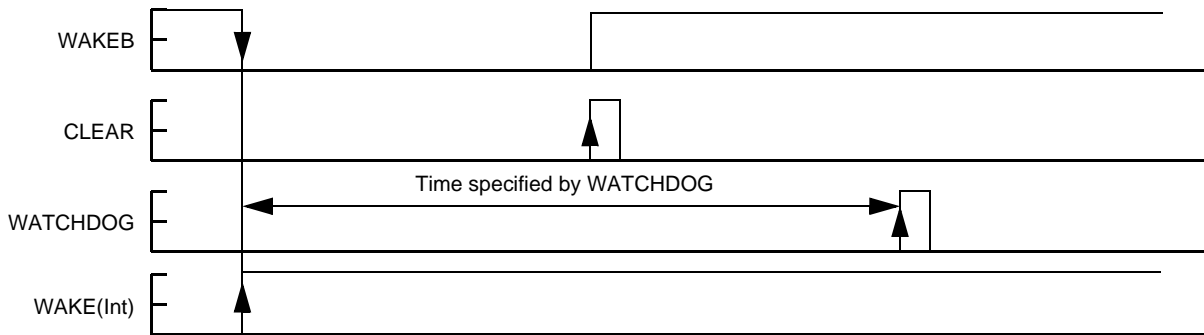

Figure 6. Start-Up Timing Diagram

STANDBY POWER SUPPLY CIRCUIT

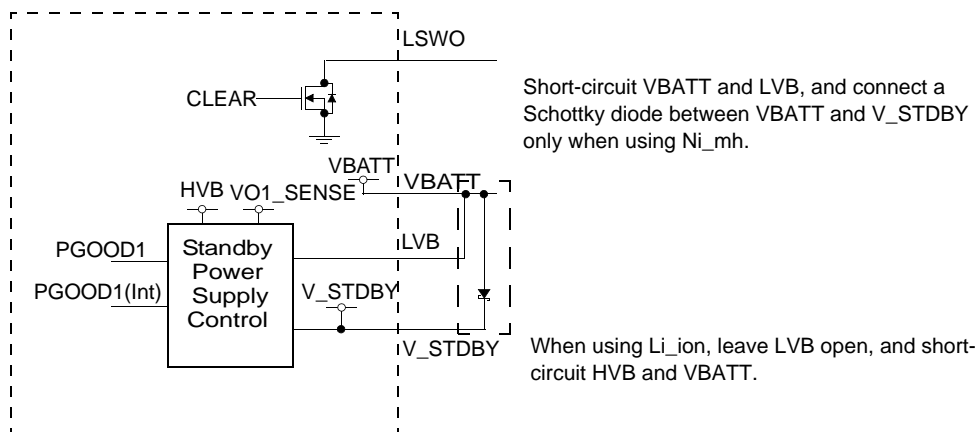

Figure 7. Standby Power Supply Circuit Diagram

When PGOOD1(int) is Low, output LVB voltage to V_STDBY pin. When PGOOD1(int) is High, output VO1_SENSE voltage to V_STDBY pin. When CLEAR is Low,

LSWO is open. When PGOOD1(int) is High and CLEAR is High, LSWO output voltage turns GND. When PGOOD1(int) is Low and PGOOD1 is High, discharge the external

capacitor which is connected to V_STDBY. When using Ni_mh, short-circuit VBATT and LVB to external components and HVB to GND. When using Li_ion, short-circuit HVB to VBATT, and leave LVB open. When using Ni_MH, the VB

voltage is output from V_STDBY in Standby mode. When using Li-Ion, 50% of the VBATT voltage is output to V_STDBY pin in Standby Mode.

Table 8. HVB and LVB Connection

MODE	HVB	LVB
Li_ion	VBATT ⁽²⁷⁾	open
Ni_mh	GND	VBATT ⁽²⁷⁾

Notes
 27. Externally connect to VBATT.

Table 9. V_STDBY and LSWO Operation

INPUT			OUTPUT	
WAKE(Int)	PGOOD2(Int)	CLEAR	V_STDBY	LSWO
L	X	X	VBATT	Z
H	L	X	VBATT	Z
H	H	L	VO1_SENSE	Z
H	H	H	VO1_SENSE	L

Z : High Impedance, X : Don't care

RESET CIRCUIT

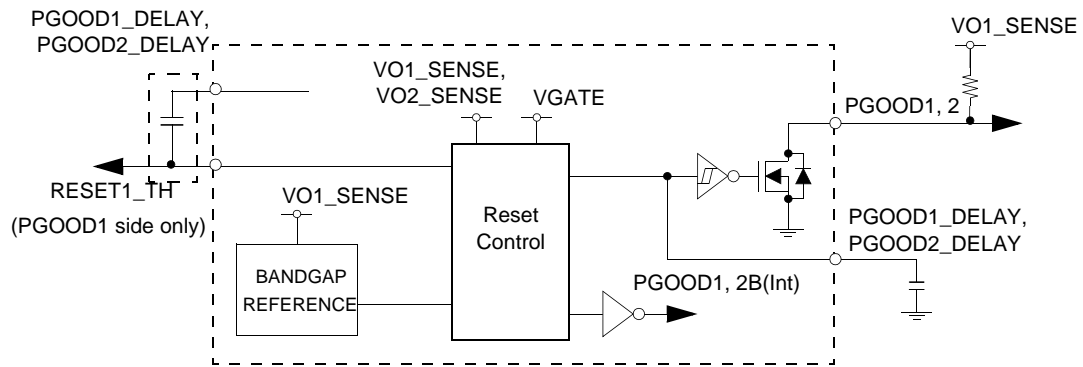

Figure 8. Reset Circuit Block Diagram

When the VO1_SENSE or VO2_SENSE voltage is higher than the reference value, PGOOD1 or 2B goes High. When PGOOD1(int) is Low and PGOOD1 is High, SLEEP(int) is forced to place the chip into the standby mode.

Connect a capacitor between RESET1_TH and PGOOD_DELAY. The capacitor is not necessary if a resistor of 330KΩ or less is inserted between RESET1_TH and VO1_SENSE for reset adjustment

Connect the capacitor between RESET1_TH and PGOOD as directed below.

When SEQ_SELECT is Low:Between RESET1_TH and PGOOD1_DELAY

When SEQ_SELECT is High:Between RESET1_TH and PGOOD2_DELAY

Use a capacitor with approximately half of the capacitance between PGOOD_DELAY and GND

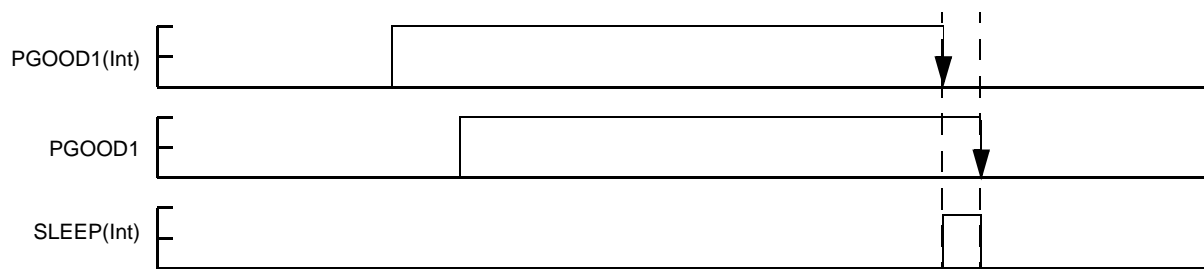

Figure 9. Reset Timing Diagram

**POWER SUPPLY VO1_SENSE, VO2_SENSE:
NI_MH**

The VBATT voltage rises and is output to VIN1. When PGOOD2(int) is High, the power switch turns ON to output the VO1_SENSE voltage to VOUT1. Capacitance value which is connected to VO1_SENSE should be higher than the capacitor connected to VOUT1.

The VBATT voltage rises or falls and is output to VIN2. When PGOOD2(int) is High, the power switch turns ON to output the VO2_SENSE_IN voltage to VOUT2. If you turn DDC2 OFF using the register, the power switch 2 also turns OFF. Capacitance value which is connected to VO2_SENSE_IN should be higher than the capacitor connected to VOUT2.

Table 10. Output Voltage of VO1_SENSE

Address: 0011 ⁽²⁸⁾								
B7	B6	B5	B4	B3	B2	B1	S_Off_VO1_SENSE	VO1_SENSE [V] ⁽²⁹⁾
L	L	L	L	L	L	L	X	1.613
L	L	L	L	L	L	H	X	1.625
L	L	L	L	L	H	L	X	1.638
L	L	L	L	H	L	L	X	1.663
L	L	L	H	L	L	L	X	1.713
L	L	H	L	L	L	L	X	1.813
L	H	L	L	L	L	L	X	2.013
H	L	L	L	L	L	L	X	2.413
H	L	L	L	L	L	H	X	2.425
H	L	L	L	L	H	L	X	2.438
H	L	L	L	H	L	L	X	2.463
H	L	L	H	L	L	L	X	2.513
H	L	H	L	L	L	L	X	2.613
H	H	L	L	L	L	L	X	2.813
H	H	H	H	H	H	H	X	3.200

Notes

- 28. All combinations of input are not included.
- 29. Operation is not guaranteed when VO1_SENSE input voltage is 1.8 V or lower. By connecting a diode between VIN1 and VO1_SENSE, VIN1 can output voltage higher (with the voltage difference Vf) than VO1_SENSE.

Table 11. Output Voltage of VO2_SENSE

Address: 0100 ⁽³³⁾								
B7	B6	B5	B4	B3	B2	B1	S_Off_VO2_SENSE	VO2_SENSE [V]
L	L	L	L	L	L	L	X	0.805
L	L	L	L	L	L	H	X	0.811
L	L	L	L	L	H	L	X	0.816
L	L	L	L	H	L	L	X	0.827
L	L	L	H	L	L	L	X	0.849
L	L	H	L	L	L	L	X	0.893
L	H	L	L	L	L	L	X	0.980
H	L	L	L	L	L	L	X	1.155
H	L	L	L	L	L	H	X	1.161
H	L	L	L	L	H	L	X	1.166
H	L	L	L	H	L	L	X	1.177
H	L	L	H	L	L	L	X	1.199
H	L	H	L	L	L	L	X	1.243
H	H	L	L	L	L	L	X	1.330
H	H	H	H	H	H	H	X	1.500

Notes

30. All combinations of input are not included

POWER SUPPLY VO1_SENSE, VO2_SENSE: LI-ION

The VBATT voltage falls and is output to VO1_SENSE. When using Li_ion, duty limit due to DMAX1 is not applied to the switch. When PGOOD2(int) is High, the power switch turns ON to output the VO1_SENSE voltage to VOUT1. Capacitance value which is connected to VO1_SENSE should be higher than the capacitor connected to VOUT1.

The VBATT voltage falls using only the internal transistor and is output to VO2_SENSE. When using Li_ion, duty limit due to DMAX2 is not applied to the switch, and HG and LG are Low. When PGOOD2(int) is High, the power switch turns

ON to output the VO2_SENSE_IN voltage to VOUT2. If you turn DDC2 OFF using the register, the power switch 2 also turns OFF. Capacitance value which is connected to VO2_SENSE_IN should be higher than the capacitor connected to VOUT2.

SERIES PASS POWER SUPPLY

The series pass outputs the SREGI1 voltage to SREGO1, the SREGI2 voltage to SREGO2, and the SREGI3 voltage to SREGO3. If you use MOSFET as the external component in this case, connect the gate to SREG2G.

Table 12. Output Voltage of SREG1

Address: 0101 ⁽³¹⁾								
B7	B6	B5	B4	B3	B2	B1	Reserved	SREG1 [V] ⁽³³⁾
L	L	L	L	L	L	L	H	0.865
L	L	L	L	L	L	H	H	0.880
L	L	L	L	L	H	L	H	0.895
L	L	L	L	H	L	L	H	0.926
L	L	L	H	L	L	L	H	0.986
L	L	H	L	L	L	L	H	1.107

Table 12. Output Voltage of SREG1

Address: 0101 ⁽³¹⁾								
B7	B6	B5	B4	B3	B2	B1	Reserved	SREG1 [V] ⁽³³⁾
L	H	L	L	L	L	L	H	1.349
H	L	L	L	L	L	L	H	1.833
H	L	L	L	L	L	H	H	1.848
H	L	L	L	L	H	L	H	1.863
H	L	L	L	H	L	L	H	1.893
H	L	L	H	L	L	L	H	1.954
H	L	H	L	L	L	L	H	2.075
H	H	L	L	L	L	L	H	2.317
H	H	H	H	H	H	H	H	2.800

Notes

31. All combinations of input are not included.
32. The SREG1 and 3 output voltages are determined by the combination of external resistances connected to SREGC1 and 3 (65.14K Ω between SREGO1 and SREGC1, 34.86K Ω between SREGC1 and GND, 73.84K Ω between SREGO3 and SREGC3, and 26.16K Ω between SREGC3 and GND).

Table 13. Output Voltage of SREG2

Address: 0110 ⁽³³⁾								
B7	B6	B5	B4	B3	B2	B1	B0	SREG2 [V]
L	L	L	L	L	L	L	L	0.011
L	L	L	L	L	L	L	H	0.022
L	L	L	L	L	L	H	L	0.033
L	L	L	L	L	H	L	L	0.055
L	L	L	L	H	L	L	L	0.098
L	L	L	H	L	L	L	L	0.186
L	L	H	L	L	L	L	L	0.361
L	H	L	L	L	L	L	L	0.711
H	L	L	L	L	L	L	L	1.411
H	L	L	L	L	L	L	H	1.422
H	L	L	L	L	L	H	L	1.433
H	L	L	L	L	H	L	L	1.455
H	L	L	L	H	L	L	L	1.498
H	L	L	H	L	L	L	L	1.586
H	L	H	L	L	L	L	L	1.761
H	H	L	L	L	L	L	L	2.111
H	H	H	H	H	H	H	H	2.800

Notes

33. All combinations of input are not included.

Table 14. Output Voltage of SREG3

Address: 0111 ⁽³⁴⁾								
B7	B6	B5	B4	B3	B2	CP Off	EXTG On	SREG3 [V] ⁽³⁵⁾
L	L	L	L	L	L	X	X	2.080

Table 14. Output Voltage of SREG3

Address: 0111 ⁽³⁴⁾								
B7	B6	B5	B4	B3	B2	CP Off	EXTG On	SREG3 [V] ⁽³⁵⁾
L	L	L	L	L	H	X	X	2.091
L	L	L	L	H	L	X	X	2.102
L	L	L	H	L	L	X	X	2.125
L	L	H	L	L	L	X	X	2.170
L	H	L	L	L	L	X	X	2.260
H	L	L	L	L	L	X	X	2.440
H	L	L	L	L	H	X	X	2.451
H	L	L	L	H	L	X	X	2.462
H	L	L	H	L	L	X	X	2.485
H	L	H	L	L	L	X	X	2.530
H	H	L	L	L	L	X	X	2.620
H	H	H	H	H	H	X	X	2.800

Notes

- 34. All combinations of input are not included.
- 35. The SREG1 and 3 output voltages are determined by the combination of external resistances connected to SREGC1 and 3 (65.14K Ω between SREGO1 and SREGC1, 34.86K Ω between SREGC1 and GND, 73.84K Ω between SREGO3 and SREGC3, and 26.16K Ω between SREGC3 and GND).

VG GENERATOR

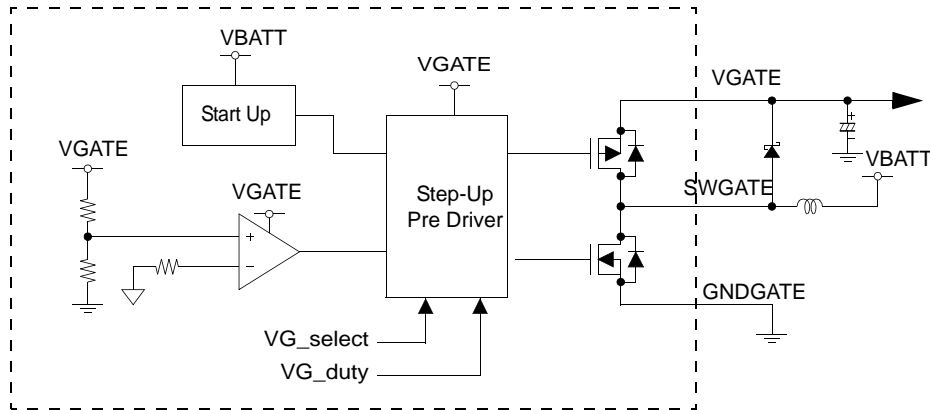

Figure 10. Circuit when using a Step-Up Converter

When WAKE (int) goes High from Low, the start-up circuit raises the VB voltage and outputs it to VGATE, then outputs the VGATE voltage when PGOOD1 (int) goes High. The charge pump circuit can be used for both Ni_mh and Li_ion by setting the necessary registers. The charge pump circuit is disabled by default.

The VGATE voltage can be set in the range of 6 V to 4.5 V according to the combination of VGATESEL1 and 2 pin connections. Refer to [Table 16, VGATE Voltage Settings and VGATESEL1 and 2 Pin Connection](#) on page 23 for the VG voltage settings.

When using a charge pump, please refer to [Figure 11](#).

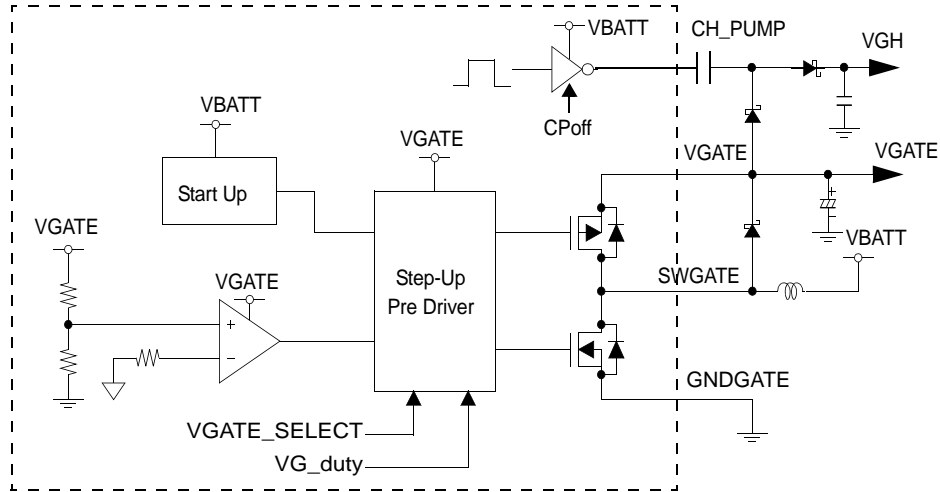

Figure 11. Circuit When Using a Charge Pump

Table 15. VGATE Duty Settings

Address : 0010								
Ext/Int	Half Freq	RSTB sleep	S_Off_VG	VG_Duty[3]	VG_Duty[2]	VG_Duty[1]	VG_Duty[0]	Duty
X	X	X	X	L	L	L	L	90 %
X	X	X	X	L	L	L	H	86 %
X	X	X	X	L	L	H	L	82 %
X	X	X	X	L	H	L	L	74 %
X	X	X	X	H	L	L	L	58 %
X	X	X	X	H	L	L	H	54 %
X	X	X	X	H	L	H	L	50 %
X	X	X	X	H	H	L	L	42 %
X	X	X	X	H	H	H	H	30 %

Table 16. VGATE Voltage Settings and VGATESEL1 and 2 Pin Connection

VGATESEL1	VGATESEL2	VGATE [V]
GND	GND	6.0
GND	VBATT	5.5
VBATT	GND	5.0
VBATT	VBATT	4.5

LOGIC COMMANDS AND REGISTERS

REGISTER MAPPINGS

Table 17. CLEAR and SLEEP Control Register

1000	Data1				Data2			
Bit	3	2	1	0	3	2	1	0
Name	CLEAR	SLEEP	Reserved	Reserved	Reserved	Reserved	Reserved	Reserved
Default	0	0	0	0	0	0	0	0

CLEAR: CLEAR Control

1 = CLEAR is high

0 = CLEAR is low

SLEEP: SLEEP Control

1 = SLEEP is high

0 = SLEEP is low

Reserved: Freescale defined register *1

1 = Forbidden

0 = Required

Reserved: Freescale defined register *1

1 = Forbidden

0 = Required

Reserved: Freescale defined register *1

1 = Forbidden

0 = Required

Reserved : Freescale defined register *1

1 = Forbidden

0 = Required

Reserved : Freescale defined register *1

1 = Forbidden

0 = Required

Reserved: Freescale defined register *1

1 = Forbidden

0 = Required

Note: Do NOT change Reserved Register from default value.

*1: Data write to this address (1000) is allowed for the most significant two bits only. The least significant 6 bits are only used for the factory test. When writing data, always write 0 to these six bits.

Table 18. Power Mode Register

0001	Data1				Data2			
Bit	3	2	1	0	3	2	1	0
Name	PSW1	PSW2	PGOOD1	VOUT2	SREG1	SREG2	SREG3	PGOOD2
Default	1	1	0	1	1	1	1	0

PSW1: VOUT1 Power Switch control

1 = Power Switch on

0 = Power Switch off

PSW2: VOUT2 Power Switch control

1 = Power Switch on

0 = Power Switch off

PGOOD1: PGOOD1 Mask *1

1 = PGOOD1 mask on

0 = PGOOD1 mask off

VO2_SENSE: DC/DC Converter Channel 2 output Control

*2

1 = DDC2 on

0 = DDC2 off

SREG1: Series Pass Regulator Channel1 output Control

1 = Regulator on

0 = Regulator off

SREG2: Series Pass Regulator Channel2 output

Control *3

1 = Regulator off

0 = Regulator on

SREG3: Series Pass Regulator Channel3 output Control

1 = Regulator on

0 = Regulator off

PGOOD2: PGOOD2 Mask *1

1 = PGOOD2 mask on

0 = PGOOD2 mask off

*1: When switching the output voltage of VO1_SENSE (2), write 1 to the PGOOD1 (2) Mask bit in advance to fix the rest output to High for preventing erroneous operation.

*2: When turning DDC2 OFF, set the PGOOD2 bit to High to Mask PGOOD2. If you turn DDC2 OFF, the power switch 2 also turns OFF.

Table 19. Clock Select Register

0010	Data1				Data2			
Bit	3	2	1	0	3	2	1	0
Name	Ext/Int	Half Freq	RSTB sleep	S_Off_VG	VG_Duty [3]	VG_Duty[2]	VG_Duty[1]	VG_Duty[0]
Default	0	0	1	0	0	0	0	0

Ext / Int: Clock Select control 1
 1 = External Clock
 0 = Internal Clock

2FS: Clock Select control 2
 1 = 2FS on
 0 = 2FS off

RSTB Sleep: RSTB Sleep Monitor *1
 1 = RSTB SLEEP Monitor off
 0 = RSTB SLEEP Monitor on

S_Off_VG: VG Top side transistor off
 1 = Synchronous Rectification Off
 0 = Synchronous Rectification On

VG_Duty[3]: VG Duty Control MSB
 1 = VG Duty[3] is high
 0 = VG Duty[3] is low

VG_Duty[2]: VG Duty Control Bit 2
 1 = VG Duty[2] is high
 0 = VG Duty[2] is low

VG_Duty[1]: VG Duty Control Bit1
 1 = VG Duty[1] is high
 0 = VG Duty[1] is low

VG_Duty[0]: VG Duty Control LSB
 1 = VG Duty[0] is high
 0 = VG Duty[0] is low

VG is controlled by PFM method. This register can change the duty by 16 steps.

Refer to [Table 15. VGATE Duty Settings](#) on page 23 for the correspondence between the VG Duty maximum values and register settings.

Table 20. VO1_SENSE Output Voltage Register

0011	Data1				Data2			
Bit	3	2	1	0	3	2	1	0
Name	VO1_SENSE [6]	VO1_SENSE [5]	VO1_SENSE [4]	VO1_SENSE [3]	VO1_SENSE [2]	VO1_SENSE [1]	VO1_SENSE [0]	S_Off_VO1_SENSE
Default	1	0	0	0	0	0	0	0

VO1_SENSE[6]: Reference DAC MSB
 1 = VO1_SENSE[6] on
 0 = VO1_SENSE[6] off

VO1_SENSE[5]: Reference DAC Bit5
 1 = VO1_SENSE[5] on
 0 = VO1_SENSE[5] off

VO1_SENSE[4]: Reference DAC Bit4
 1 = VO1_SENSE[4] on
 0 = VO1_SENSE[4] off

VO1_SENSE[3]: Reference DAC Bit3
 1 = VO1_SENSE[3] on
 0 = VO1_SENSE[3] off

VO1_SENSE[2]: Reference DAC Bit2
 1 = VO1_SENSE[2] on
 0 = VO1_SENSE[2] off

VO1_SENSE[1]: Reference DAC Bit1
 1 = VO1_SENSE[1] on
 0 = VO1_SENSE[1] off

VO1_SENSE[0]: Reference DAC Bit0
 1 = VO1_SENSE[0] on
 0 = VO1_SENSE[0] off

S_Off_VO1_SENSE: DDC1 Top side (Ni_mh) / Bottom side (Li_ion) transistor off
 1 = Synchronous Rectification Off
 0 = Synchronous Rectification On

Refer to [Table 10. Output Voltage of VO1_SENSE](#) on page 19 for the correspondence between the output voltage and register settings.

Table 21. VO2_SENSE Output Voltage Register

0100	Data1				Data2			
Bit	3	2	1	0	3	2	1	0
Name	VO2_SENSE [6]	VO2_SENSE [5]	VO2_SENSE [4]	VO2_SENSE [3]	VO2_SENSE [2]	VO2_SENSE [1]	VO2_SENSE [0]	S_Off_VO2_SENSE
Default	1	0	0	0	0	0	0	0

VO2_SENSE[6]: Reference DAC MSB

1 = VO2_SENSE[6] on
 0 = VO2_SENSE[6] off

VO2_SENSE[5]: Reference DAC Bit5

1 = VO2_SENSE[5] on
 0 = VO2_SENSE[5] off

VO2_SENSE[4]: Reference DAC Bit4

1 = VO2_SENSE[4] on
 0 = VO2_SENSE[4] off

VO2_SENSE[3]: Reference DAC Bit3

1 = VO2_SENSE[3] on
 0 = VO2_SENSE[3] off

VO2_SENSE[2]: Reference DAC Bit2

1 = VO2_SENSE[2] on
 0 = VO2_SENSE[2] off

VO2_SENSE[1]: Reference DAC Bit1

1 = VO2_SENSE[1] on
 0 = VO2_SENSE[1] off

VO2_SENSE [0]: Reference DAC LSB

1 = VO2_SENSE [0] on
 0 = VO2_SENSE [0] off

S_Off_VO2_SENSE: DDC2 Top side & LG (Ni_mh) / Bottom side (Li_ion) transistor off

1 = Synchronous Rectification Off

0 = Synchronous Rectification On

Refer to [Table 11, Output Voltage of VO2_SENSE](#) on page 20 for the correspondence between the output voltage and register settings.

Table 22. Regulator1 Output Voltage Register

0101	Data1				Data2			
Bit	3	2	1	0	3	2	1	0
Name	SREG1_V[6]	SREG1_V[5]	SREG1_V[4]	SREG1_V[3]	SREG1_V[2]	SREG1_V[1]	SREG1_V[0]	Reserved
Default	1	1	1	1	1	1	1	1

SREG1_V[6]: Reference DAC MSB

1 = SREG1_V[6] on
 0 = SREG1_V[6] off

SREG1_V[5]: Reference DAC Bit5

1 = SREG1_V[5] on
 0 = SREG1_V[5] off

SREG1_V[4]: Reference DAC Bit4

1 = SREG1_V[4] on
 0 = SREG1_V[4] off

SREG1_V[3]: Reference DAC Bit3

1 = SREG1_V[3] on
 0 = SREG1_V[3] off

SREG1_V[2] : Reference DAC Bit2

1 = SREG1_V[2] on
 0 = SREG1_V[2] off

SREG1 [1]: Reference DAC Bit1

1 = SREG1_V[1] on
 0 = SREG1_V[1] off

SREG1_V[0]: Reference DAC LSB

1 = SREG1_V[0] on
 0 = SREG1_V[0] off

Reserved : Blank register bit (Freescale Pre-Defined Register)

1 = Preferred

0 = Forbidden

Note: Do NOT change Reserved Register from default value.

Refer to [Table 12, Output Voltage of SREG1](#) on page 20 for the correspondence between the output voltage and register settings.

Table 23. Regulator2 Output Voltage Register

0110	Data1				Data2			
Bit	3	2	1	0	3	2	1	0
Name	SREG2_V[7]	SREG2_V[6]	SREG2_V[5]	SREG2_V[4]	SREG2_V[3]	SREG2_V[2]	SREG2_V[1]	SREG2_V[0]
Default	1	1	1	1	1	1	1	1

SREG2_V[7]: Reference DAC MSB
1 = SREG2_V[7] on
0 = SREG2_V[7] off

SREG2_V[6]: Reference DAC Bit6
1 = SREG2_V[6] on
0 = SREG2_V[6] off

SREG2_V[5]: Reference DAC Bit5
1 = SREG2_V[5] on
0 = SREG2_V[5] off

SREG2_V[4]: Reference DAC Bit4
1 = SREG2_V[4] on
0 = SREG2_V[4] off

SREG2_V[3]: Reference DAC Bit3
1 = SREG2_V[3] on
0 = SREG2_V[3] off

SREG2_V[2]: Reference DAC Bit2
1 = SREG2_V[2] on
0 = SREG2_V[2] off

SREG2_V[1]: Reference DAC Bit1
1 = SREG2_V[1] on
0 = SREG2_V[1] off

SREG2_V[0]: Reference DAC LSB
1 = SREG2_V[0] on
0 = SREG2_V[0] off

Refer to [Table 13, Output Voltage of SREG2](#) on page 21 for the correspondence between the output voltage and register settings.

Table 24. Regulator3 Output Voltage Register

0111	Data1				Data2			
Bit	3	2	1	0	3	2	1	0
Name	SREG3_V[5]	SREG3_V[4]	SREG3_V[3]	SREG3_V[2]	SREG3_V[1]	SREG3_V[0]	CP Off	EXTG On
Default	1	1	1	1	1	1	1	1

SREG3_V[5]: Reference DAC MSB
1 = SREG3_V[5] on
0 = SREG3_V[5] off

SREG3_V[4]: Reference DAC Bit4
1 = SREG3_V[4] on
0 = SREG3_V[4] off

SREG3_V[3]: Reference DAC Bit3
1 = SREG3_V[3] on
0 = SREG3_V[3] off

SREG3_V[2]: Reference DAC Bit2
1 = SREG3_V[2] on
0 = SREG3_V[2] off

SREG3_V[1]: Reference DAC Bit1
1 = SREG3_V[1] on
0 = SREG3_V[1] off

SREG3_V[0]: Reference DAC LSB
1 = SREG3_V[0] on
0 = SREG3_V[0] off

CP Off: Charge Pump Control
1 = Charge Pump off
0 = Charge Pump on

EXTG On: VGATE_EXT Control *
1 = VGATE_EXT is low (GND level)
0 = VGATE_EXT is high (VG level)

EXTG On Register is assumed to use Pch FET as external MOSFET.

If Nch FET will be used, Control logic should be inverted.

Refer to [Table 14, Output Voltage of SREG3](#) on page 21 for the correspondence between the output voltage and register settings.

TYPICAL APPLICATIONS

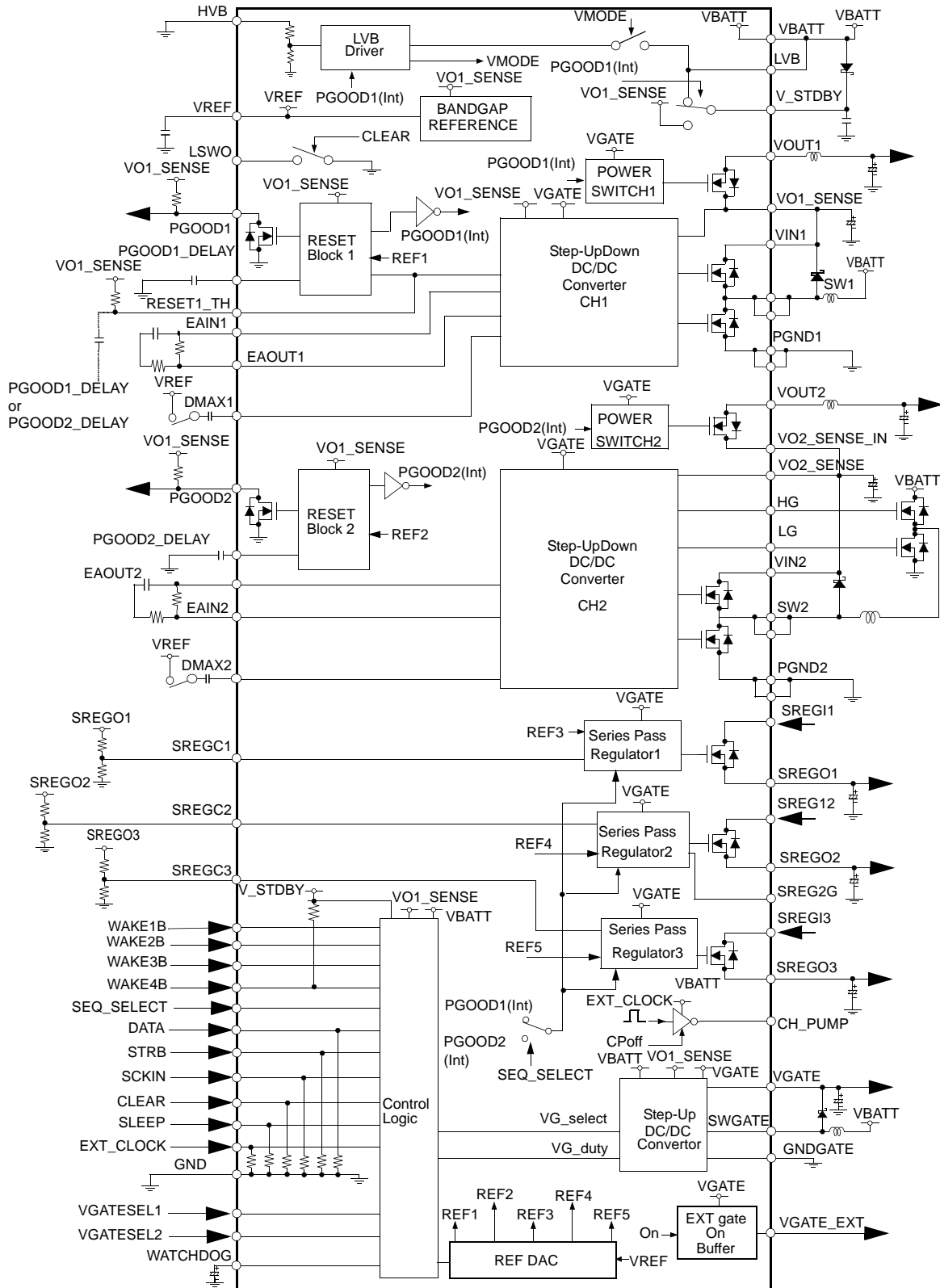

Figure 12. MPC18730 Typical Application Diagram (Ni-MH Battery)

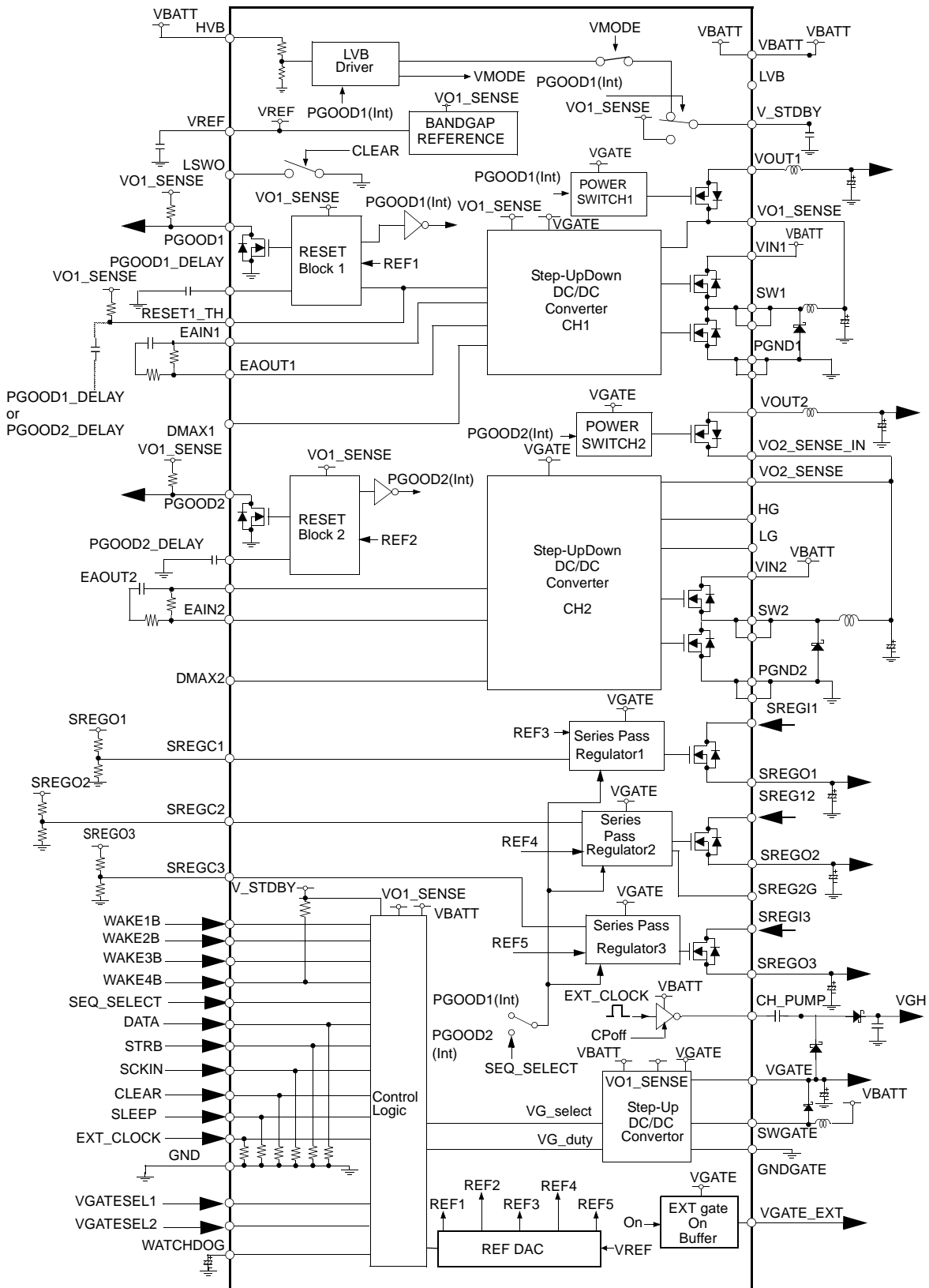
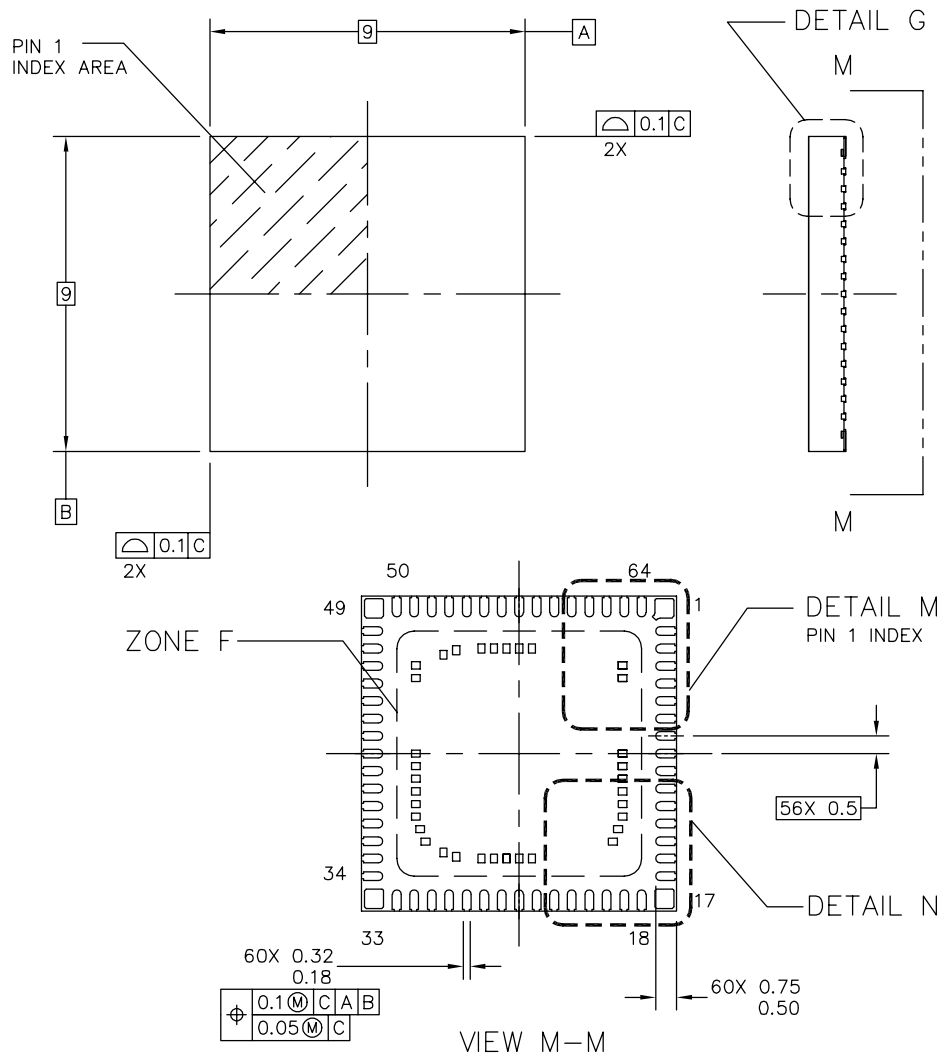

Figure 13. MPC18730 Typical Application Diagram (Li-Ion Battery)

PACKAGING

PACKAGE DIMENSIONS

For the most current package revision, visit www.freescale.com and perform a keyword search using the "98A" listed below.



© FREESCALE SEMICONDUCTOR, INC. ALL RIGHTS RESERVED.	MECHANICAL OUTLINE	PRINT VERSION NOT TO SCALE
TITLE: QUAD FLAT NON-LEADED PACKAGE (QFN), 64 TERMINAL 0.5 PITCH(9 X 9 X 0.75)	DOCUMENT NO: 98ARL10571D	REV: B
	CASE NUMBER: 1497-02	12 AUG 2005
	STANDARD: NON-JEDEC	

EP (Pb-FREE) SUFFIX
64-PIN 0.5 mm pitch
PLASTIC PACKAGE
98ARL10571D
ISSUE B

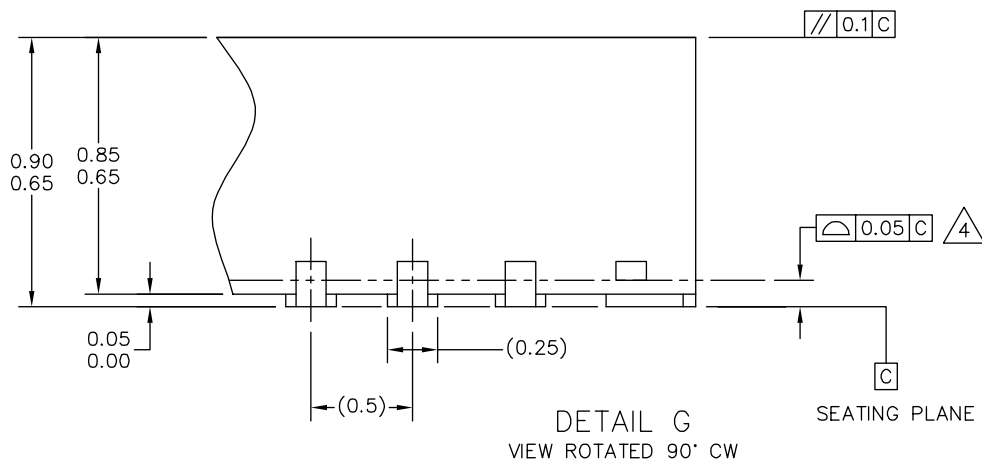
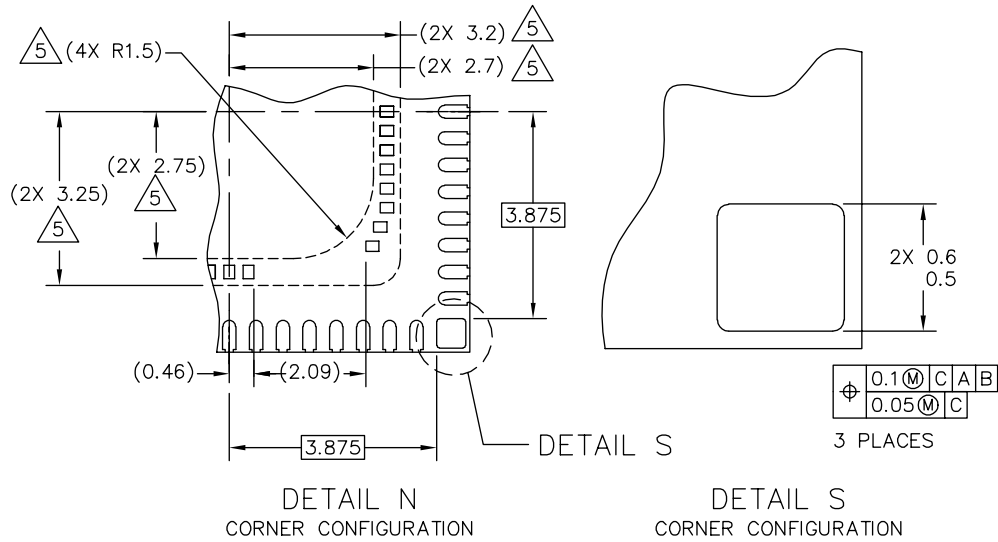

© FREESCALE SEMICONDUCTOR, INC. ALL RIGHTS RESERVED.	MECHANICAL OUTLINE	PRINT VERSION NOT TO SCALE
TITLE: QUAD FLAT NON-LEADED PACKAGE (QFN), 64 TERMINAL 0.5 PITCH(9 X 9 X 0.75)	DOCUMENT NO: 98ARL10571D	REV: B
	CASE NUMBER: 1497-02	12 AUG 2005
	STANDARD: NON-JEDEC	

EP (Pb-FREE) SUFFIX
64-PIN 0.5 mm pitch
PLASTIC PACKAGE
98ARL10571D
ISSUE B

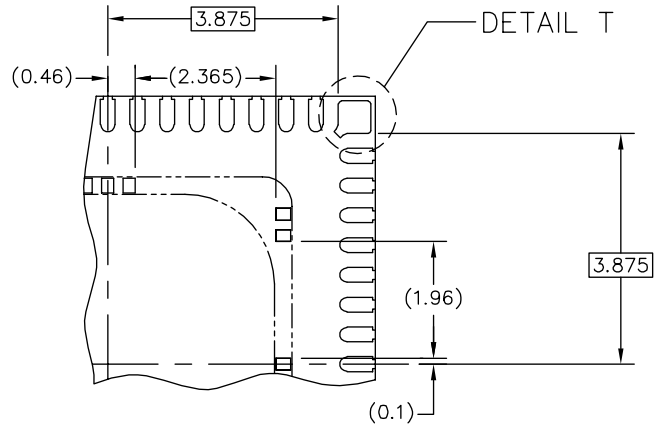

DETAIL M
BACKSIDE PIN 1 INDEX

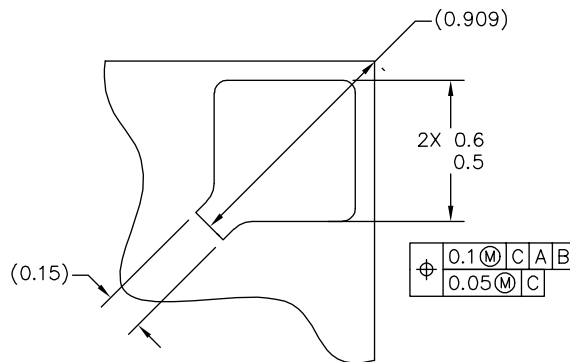

DETAIL T
BACKSIDE PIN 1 INDEX

© FREESCALE SEMICONDUCTOR, INC. ALL RIGHTS RESERVED.	MECHANICAL OUTLINE	PRINT VERSION NOT TO SCALE	
TITLE: QUAD FLAT NON-LEADED PACKAGE (QFN), 64 TERMINAL 0.5 PITCH(9 X 9 X 0.75)	DOCUMENT NO: 98ARL10571D	REV: B	
	CASE NUMBER: 1497-02	12 AUG 2005	
	STANDARD: NON-JEDEC		

EP (Pb-FREE) SUFFIX
64-PIN 0.5 mm pitch
PLASTIC PACKAGE
98ARL10571D
ISSUE B

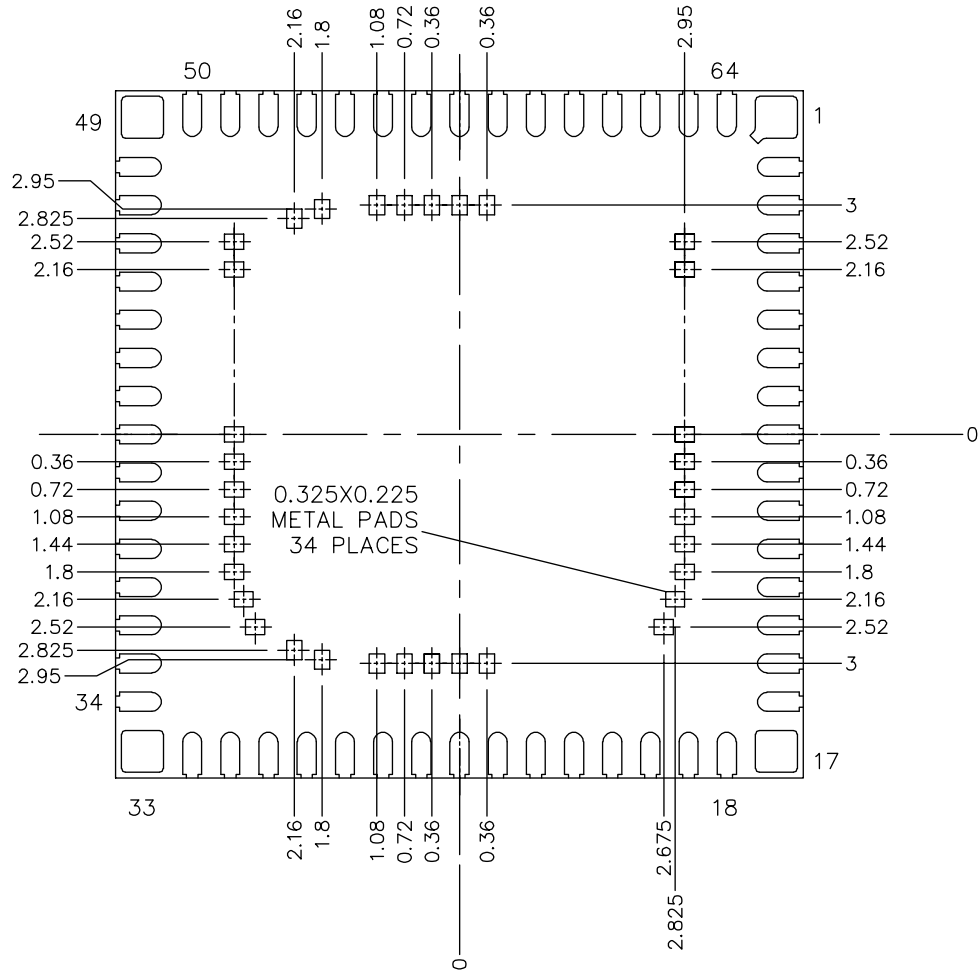

ZONE F DETAIL

© FREESCALE SEMICONDUCTOR, INC. ALL RIGHTS RESERVED.	MECHANICAL OUTLINE	PRINT VERSION NOT TO SCALE	
TITLE: QUAD FLAT NON-LEADED PACKAGE (QFN), 64 TERMINAL 0.5 PITCH(9 X 9 X 0.75)	DOCUMENT NO: 98ARL10571D	REV: B	
	CASE NUMBER: 1497-02	12 AUG 2005	
	STANDARD: NON-JEDEC		

EP (Pb-FREE) SUFFIX
64-PIN 0.5 mm pitch
PLASTIC PACKAGE
98ARL10571D
ISSUE B

REVISION HISTORY

REVISION	DATE	DESCRIPTION OF CHANGES
3.0	04/2006	<ul style="list-style-type: none">• Changed 34 of 64 Pin names to align with Application Note, AN3247 Rev 1.0.
4.0	8/2006	<ul style="list-style-type: none">• Minor changes to correct errors and inconsistencies.• Updated form and style.

How to Reach Us:

Home Page:

www.freescale.com

E-mail:

support@freescale.com

USA/Europe or Locations Not Listed:

Freescale Semiconductor
Technical Information Center, CH370
1300 N. Alma School Road
Chandler, Arizona 85224
+1-800-521-6274 or +1-480-768-2130
support@freescale.com

Europe, Middle East, and Africa:

Freescale Halbleiter Deutschland GmbH
Technical Information Center
Schatzbogen 7
81829 Muenchen, Germany
+44 1296 380 456 (English)
+46 8 52200080 (English)
+49 89 92103 559 (German)
+33 1 69 35 48 48 (French)
support@freescale.com

Japan:

Freescale Semiconductor Japan Ltd.
Headquarters
ARCO Tower 15F
1-8-1, Shimo-Meguro, Meguro-ku,
Tokyo 153-0064
Japan
0120 191014 or +81 3 5437 9125
support.japan@freescale.com

Asia/Pacific:

Freescale Semiconductor Hong Kong Ltd.
Technical Information Center
2 Dai King Street
Tai Po Industrial Estate
Tai Po, N.T., Hong Kong
+800 2666 8080
support.asia@freescale.com

For Literature Requests Only:

Freescale Semiconductor Literature Distribution Center
P.O. Box 5405
Denver, Colorado 80217
1-800-441-2447 or 303-675-2140
Fax: 303-675-2150
LDCForFreescaleSemiconductor@hibbertgroup.com

Information in this document is provided solely to enable system and software implementers to use Freescale Semiconductor products. There are no express or implied copyright licenses granted hereunder to design or fabricate any integrated circuits or integrated circuits based on the information in this document.

Freescale Semiconductor reserves the right to make changes without further notice to any products herein. Freescale Semiconductor makes no warranty, representation or guarantee regarding the suitability of its products for any particular purpose, nor does Freescale Semiconductor assume any liability arising out of the application or use of any product or circuit, and specifically disclaims any and all liability, including without limitation consequential or incidental damages. "Typical" parameters that may be provided in Freescale Semiconductor data sheets and/or specifications can and do vary in different applications and actual performance may vary over time. All operating parameters, including "Typicals", must be validated for each customer application by customer's technical experts. Freescale Semiconductor does not convey any license under its patent rights nor the rights of others. Freescale Semiconductor products are not designed, intended, or authorized for use as components in systems intended for surgical implant into the body, or other applications intended to support or sustain life, or for any other application in which the failure of the Freescale Semiconductor product could create a situation where personal injury or death may occur. Should Buyer purchase or use Freescale Semiconductor products for any such unintended or unauthorized application, Buyer shall indemnify and hold Freescale Semiconductor and its officers, employees, subsidiaries, affiliates, and distributors harmless against all claims, costs, damages, and expenses, and reasonable attorney fees arising out of, directly or indirectly, any claim of personal injury or death associated with such unintended or unauthorized use, even if such claim alleges that Freescale Semiconductor was negligent regarding the design or manufacture of the part.

Freescale™ and the Freescale logo are trademarks of Freescale Semiconductor, Inc. All other product or service names are the property of their respective owners.

© Freescale Semiconductor, Inc., 2006. All rights reserved.