

PA81J • PA82J SERIES

FEATURES

- HIGH VOLTAGE OPERATION — $\pm 150V$ (PA82J)
- HIGH OUTPUT CURRENT — $\pm 30mA$ (PA81J)
- LOW BIAS CURRENT, LOW NOISE — FET Input

APPLICATIONS

- HIGH IMPEDANCE BUFFERS UP TO $\pm 140V$
- ELECTROSTATIC TRANSDUCER & DEFLECTION
- PROGRAMMABLE POWER SUPPLIES TO $\pm 145V$
- BIOCHEMISTRY STIMULATORS
- COMPUTER TO VACUUM TUBE INTERFACE

DESCRIPTION

The PA80 series of high voltage operation amplifiers provides an extremely wide range of supply capability with two overlapping products. High accuracy is achieved with a cascode input circuit configuration. All internal biasing is referenced to a zener diode. As a result, these models offer outstanding common mode and power supply rejection. The output stage operates in the class A/B mode for best linearity. Internal phase compensation assures stability at all gain settings without external components. Fixed internal current limits protect these amplifiers against a short circuit to common at most supply voltages. For sustained high energy flyback, external fast recovery diodes should be used. However, a heatsink may be necessary to maintain the proper case temperature under normal operating conditions.

This hybrid circuit utilizes thick film resistors, ceramic capacitors and silicon semiconductors to maximize reliability, minimize size and give top performance. Ultrasonically bonded aluminum wires provide reliable interconnections at all operating temperatures. The 8-pin TO-3 package (see Package Outlines) is hermetically sealed and isolated from the internal circuits. The use of compressible thermal washers voids the warranty.

EXTERNAL CONNECTIONS

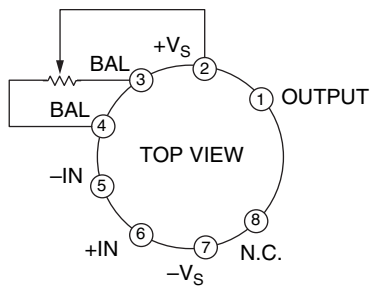

NOTE: Input offset trimpot optional.
Recommended value of 100K Ω

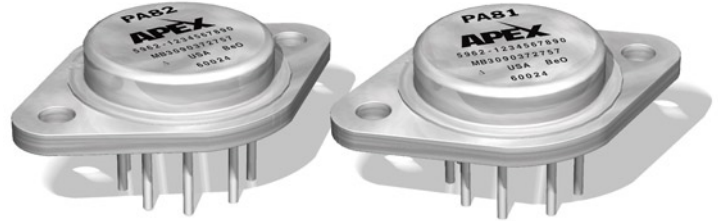

8-PIN TO-3
PACKAGE STYLE CE

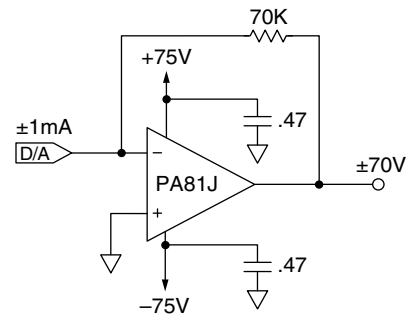

HIGH VOLTAGE PROGRAMMABLE POWER SUPPLY

TYPICAL APPLICATION

The PA81 and 70K ohm resistor form a current to voltage converter, accepting $\pm 1mA$ from a 12 bit current output digital to analog converter. The power op amp contribution to the error budget is insignificant. At a case temperature of 70°C, the combination of voltage offset and bias errors amounts to less than 31ppm of full scale range. Incorporation of the optional offset trim can further reduce these errors to under 9ppm.

EQUIVALENT SCHEMATIC

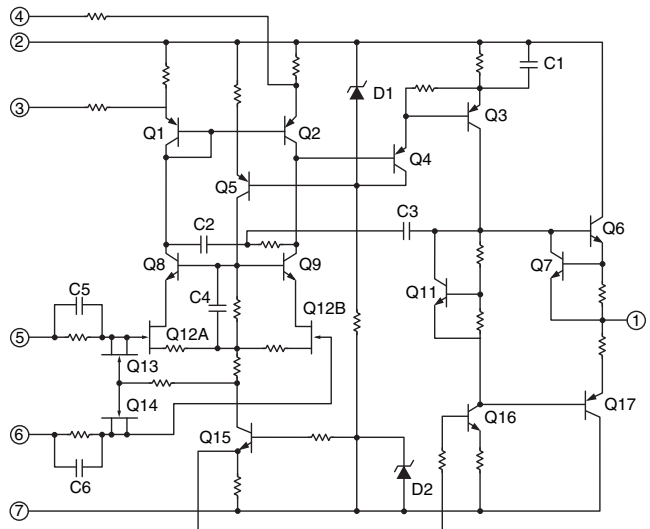

ABSOLUTE MAXIMUM RATINGS

| | PA81J | PA82J |
|--|--------------------|-----------------|
| SUPPLY VOLTAGE, +V _S to -V _S | 200V | 300V |
| OUTPUT CURRENT, within SOA | Internally Limited | |
| POWER DISSIPATION, internal | 11.5W | 11.5W |
| INPUT VOLTAGE, differential | ±150V | ±300V |
| INPUT VOLTAGE, common mode | ±V _S | ±V _S |
| TEMPERATURE, pin solder - 10 sec | 300°C | 300°C |
| TEMPERATURE, junction | 150°C | 150°C |
| TEMPERATURE RANGE, storage | -65 to +125°C | -65 to +125°C |
| OPERATING TEMPERATURE RANGE, case | -55 to +125°C | -55 to +125°C |

SPECIFICATIONS

| PARAMETER | TEST CONDITIONS ² | PA81J | | | PA82J | | | UNITS |
|---|--|---------------------|------------------|-----|-------|------|------|--------|
| | | MIN | TYP | MAX | MIN | TYP | MAX | |
| INPUT | | | | | | | | |
| OFFSET VOLTAGE, initial | T _C = 25°C | | ±1.5 | ±3 | | * | * | mV |
| OFFSET VOLTAGE, vs. temperature | Full temperature range | | 10 | 25 | | * | * | μV/°C |
| OFFSET VOLTAGE, vs. supply | T _C = 25°C | | 20 | | | * | | μV/V |
| OFFSET VOLTAGE, vs. time | T _C = 25°C | | 75 | | | * | | μV/jkh |
| BIAS CURRENT, initial | T _C = 25°C | | 5 | 50 | | * | * | pA |
| BIAS CURRENT, vs. supply | T _C = 25°C | | .2 | | | * | | pA/V |
| OFFSET CURRENT, initial | T _C = 25°C | | 2.5 | 50 | | * | * | pA |
| INPUT IMPEDANCE, DC | T _C = 25°C | | 10 ¹¹ | | | * | | Ω |
| INPUT CAPACITANCE | T _C = 25°C | | 10 | | | * | | pF |
| COMMON MODE VOLTAGE RANGE ² | Full temperature range | ±V _S -10 | | | * | | | V |
| COMMON MODE REJECTION, DC | V _{CM} = ±20V | | 110 | | | * | | dB |
| GAIN | | | | | | | | |
| OPEN LOOP GAIN at 10Hz | Full load | 94 | 116 | | 100 | 118 | | dB |
| UNITY GAIN BANDWIDTH | T _C = 25°C | | 5 | | | * | | MHz |
| POWER BANDWIDTH | T _C = 25°C, full load | | 60 | | | 30 | | kHz |
| PHASE MARGIN | Full temperature range | | 45 | | | * | | ° |
| OUTPUT | | | | | | | | |
| VOLTAGE SWING ² | T _C = 25°C, I _{PK} | ±V _S -5 | | | * | | | V |
| CURRENT, peak | T _C = 25°C | 30 | | | 15 | | | mA |
| CURRENT, limit | T _C = 25°C | | 50 | | | 25 | | mA |
| SETTLING TIME to .1% | T _C = 25°C, 10V step | | 12 | | | * | | μs |
| SLEW RATE ⁴ | T _C = 25°C | | 20 | | | * | | V/μs |
| CAPACITIVE LOAD | A _V = 1 | | 10 | | | * | | nF |
| POWER SUPPLY | | | | | | | | |
| VOLTAGE | Full temperature range | ±32 | ±75 | ±75 | ±70 | ±150 | ±150 | V |
| CURRENT, quiescent | T _C = 25°C | | 6.5 | 8.5 | | 6.5 | 8.5 | mA |
| THERMAL | | | | | | | | |
| RESISTANCE, AC, junction to case ³ | F > 60Hz | | 6 | | | * | | °C/W |
| RESISTANCE, DC, junction to case ³ | F < 60Hz | | 9 | 10 | | * | * | °C/W |
| RESISTANCE, junction to air | Full temperature range | | 30 | | | * | | °C/W |
| TEMPERATURE RANGE, shutdown | | | 150 | | | * | | °C |
| TEMPERATURE RANGE, case | Meets full range specification | 0 | | 70 | * | | * | °C |

- NOTES: * The specification of PA82J is identical to the specification for PA81J in applicable column to the left.
1. The power supply voltage for all specifications is the TYP rating unless noted as a test condition.
 2. +V_S and -V_S denote the positive and negative supply rail respectively. Total V_S is measured from +V_S to -V_S.
 3. Rating applies if the output current alternates between both output transistors at a rate faster than 60Hz.
 4. On the PA81J and PA82J, signal slew rates at pins 5 and 6 must be limited to less than 1V/ns to avoid damage. When faster waveforms are unavoidable, resistors in series with those pins, limiting current to 150mA will protect the amplifier from damage.

CAUTION

The internal substrate contains beryllia (BeO). Do not break the seal. If accidentally broken, do not crush, machine, or subject to temperatures in excess of 850°C to avoid generating toxic fumes.

PA81J • PA82J

TYPICAL PERFORMANCE GRAPHS

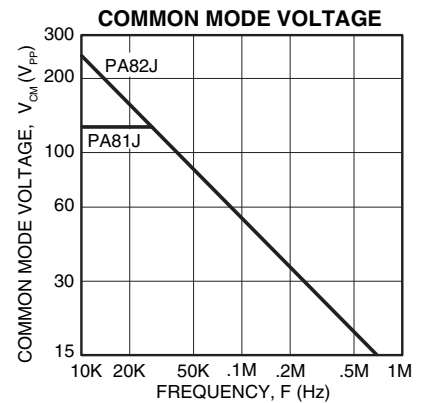
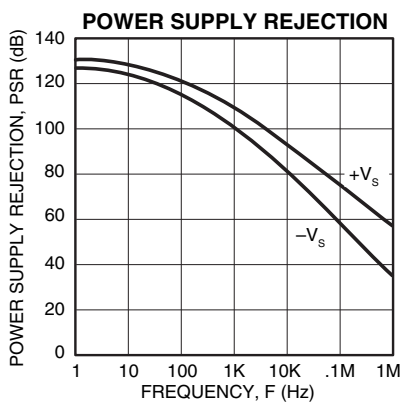
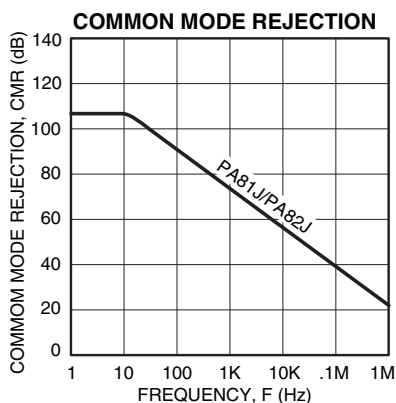
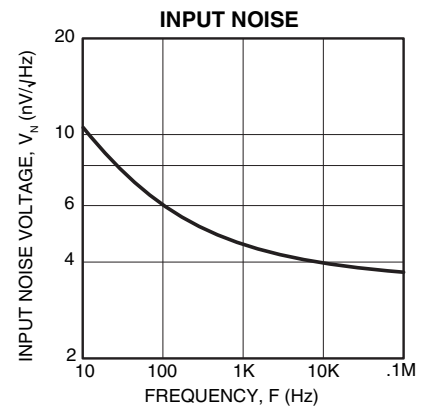
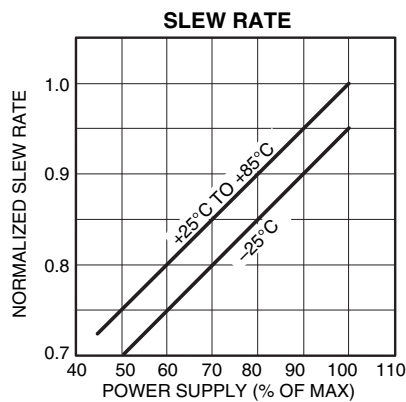
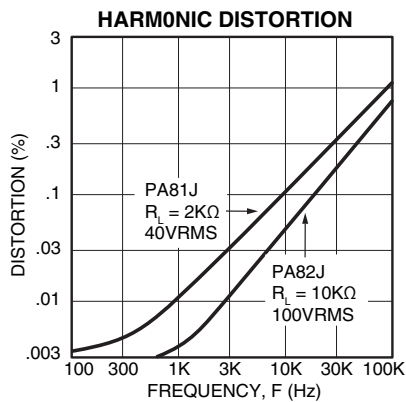
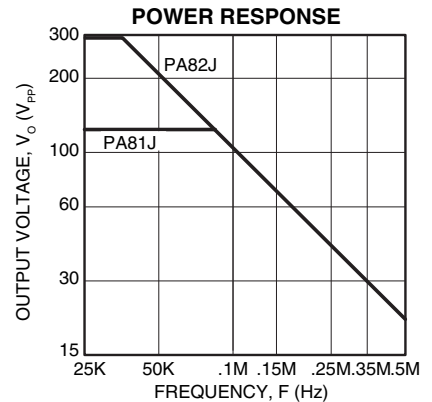
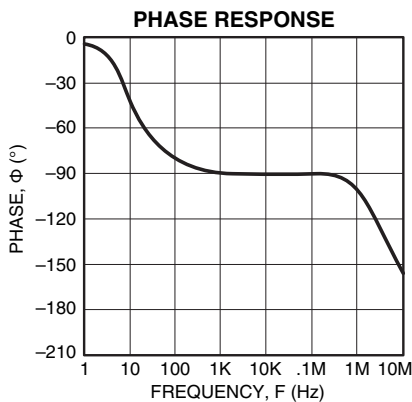
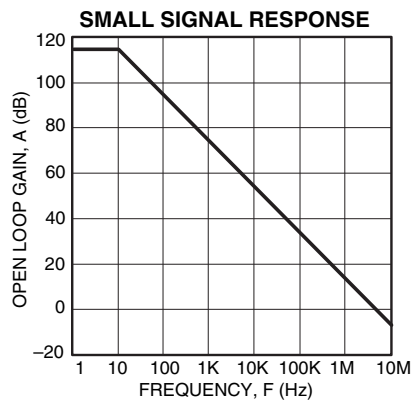
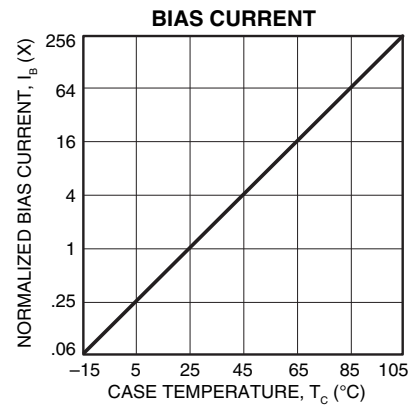
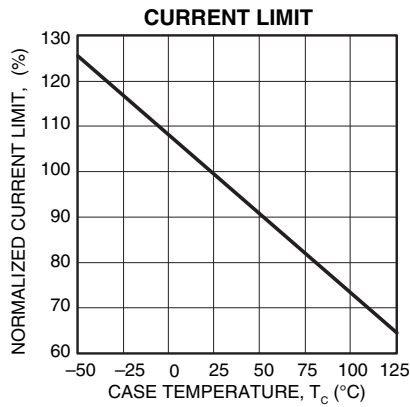
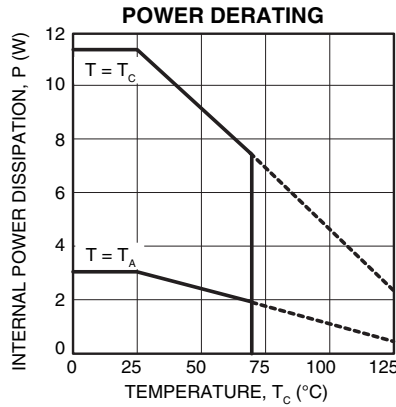

GENERAL

Please read Application Note 1 "General Operating Considerations" which covers stability, supplies, heat sinking, mounting, current limit, SOA interpretation, and specification interpretation. Visit www.apexmicrotech.com for design tools that help automate tasks such as calculations for stability, internal power dissipation, current limit and heat sink selection. The "Application Notes" and "Technical Seminar" sections contain a wealth of information on specific types of applications. Package outlines, heat sinks, mounting hardware and other accessories are located in the "Packages and Accessories" section. Evaluation Kits are available for most Apex product models, consult the "Evaluation Kit" section for details. For the most current version of all Apex product data sheets, visit www.apexmicrotech.com.

SAFE OPERATING AREA (SOA)

For the PA80J and PA81J, the combination of voltage capability and internal current limits mandate that the devices are safe for all combinations of supply voltage and load. On the PA82J, any load combination is safe up to a total supply of 250 volts. When total supply voltage equals 300 volts, the device will be safe if the output current is limited to 10 milliamps or less. This means that the PA82J used on supplies up to 125 volts will sustain a short to common or either supply without danger. When using supplies above ± 125 volts, a short to one of the supplies will be potentially destructive. When using single supply above 250 volts, a short to common will be potentially destructive.

Safe supply voltages do not imply disregard for heatsinking. The thermal calculations and the use of a heatsink are required in many applications to maintain the case temperature within the specified operating range of 0 to 70°C. Exceeding this case temperature range can result in an inoperative circuit due to excessive input errors or activation of the thermal shutdown.

INDUCTIVE LOADS

Two external diodes as shown in Figure 2, are required to protect these amplifiers against flyback (kickback) pulses exceeding the supply voltage of the amplifier when driving inductive loads. For component selection, these external diodes must be very quick, such as ultra fast recovery diodes with no more than 200 nanoseconds of reverse recovery time. Be sure the diode voltage rating is greater than the total of both supplies. The diode will turn on to divert the flyback energy into the supply rails thus protecting the output transistors from destruction due to reverse bias.

A note of caution about the supply. The energy of the flyback pulse must be absorbed by the power supply. As a result, a transient will be superimposed on the supply voltage, the magnitude of the transient being a function of its transient impedance and current sinking capability. If the supply voltage plus transient exceeds the maximum supply rating, or if the AC impedance of the supply is unknown, it is best to clamp the output and the supply with a zener diode to absorb the transient.

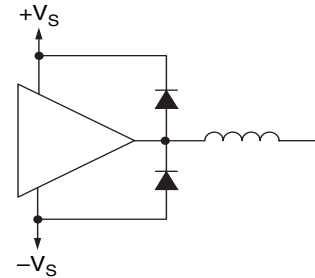

FIGURE 2.
PROTECTION,
INDUCTIVE LOAD

SINGLE SUPPLY OPERATION

These amplifiers are suitable for operation from a single supply voltage. The operating requirements do however, impose the limitation that the input voltages do not approach closer than 10 volts to either supply rail. This is due to the operating voltage requirements of the current sources, the half-dynamic loads and the cascode stage. Refer to the simplified schematics. Thus, single supply operation requires the input signals to be biased at least 10 volts from either supply rail. Figure 3 illustrates one bias technique to achieve this.

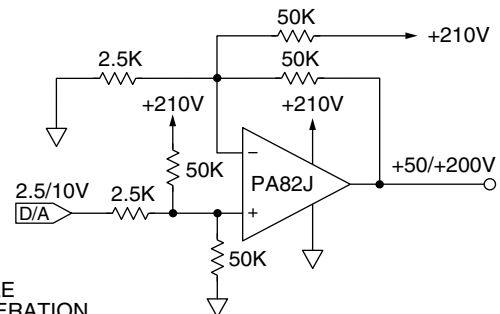

FIGURE 3.
TRUE SINGLE
SUPPLY OPERATION

Figure 4 illustrates a very common deviation from true single supply operation. The availability of two supplies still allows ground (common) referenced signals, but also maximizes the high voltage capability of the unipolar output. This technique can utilize an existing low voltage system power supply and does not place large current demands on that supply. The 12 volt supply in this case must supply only the quiescent current of the PA81J, which is 8.5mA maximum. If the load is reactive or EMF producing, the low voltage supply must also be able to absorb the reverse currents generated by the load.

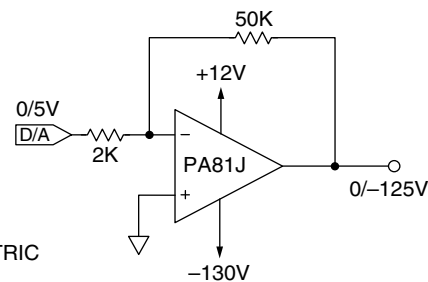

FIGURE 4.
NON-SYMMETRIC
SUPPLIES