

DESCRIPTION 2SC2369 is designed for High frequency Low Noise Amplifier.

FEATURES

- NF 1.5 dB TYP. @ f=1.0 GHz
- MAG 14 dB TYP. @ f=1.0 GHz

ABSOLUTE MAXIMUM RATINGS

Maximum Temperatures

Storage Temperature -65 to +150 °C

Junction Temperature +150 °C Maximum

Maximum Power Dissipation (Ta=25 °C)

Total Power Dissipation 250 mW

Maximum Voltages and Current (Ta=25 °C)

V_{CB0} Collector to Base Voltage 25 V

V_{CEO} Collector to Emitter Voltage 12 V

V_{EBO} Emitter to Base Voltage 3.0 V

I_C Collector Current 70 mA

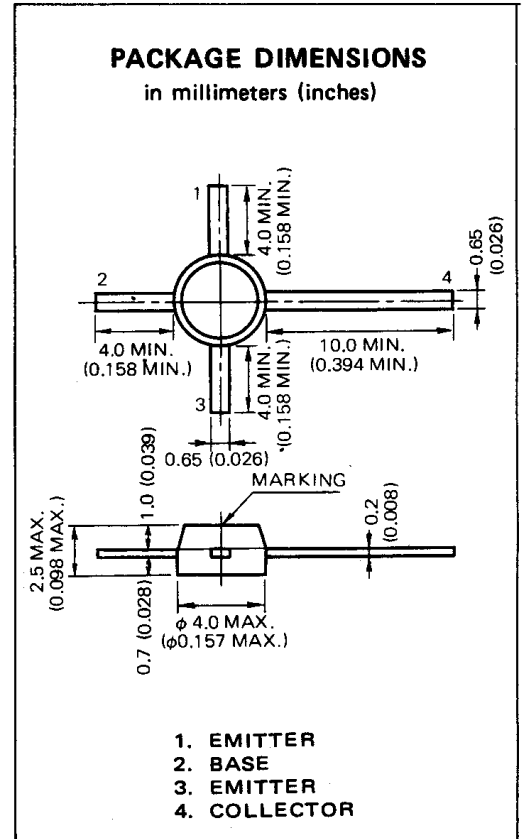

ELECTRICAL CHARACTERISTICS (Ta=25 °C)

SYMBOL	CHARACTERISTIC	MIN.	TYP.	MAX.	UNIT	TEST CONDITIONS
h _{FE}	DC Current Gain	40		200		V _{CE} =10 V, I _C =20 mA
f _T	Gain Bandwidth Product		4.5		GHz	V _{CE} =10 V, I _E =20 mA
C _{ob}	Output Capacitance		0.75	1.0	pF	V _{CB} =10 V, I _E =0, f=1.0 MHz
S _{21e} ²	Insertion Power Gain	9	11		dB	V _{CE} =10 V, I _C =20 mA, f=1.0 GHz
NF	Noise Figure		1.5	3.0	dB	V _{CE} =10 V, I _C =5 mA, f=1.0 GHz
MAG	Maximum Available Gain		14		dB	V _{CE} =10 V, I _C =20 mA, f=1.0 GHz
I _{CB0}	Collector Cutoff Current			0.1	μA	V _{CB} =15 V, I _E =0
I _{EBO}	Emitter Cutoff Current			0.1	μA	V _{EB} =2.0 V, I _C =0