

Features

- ❑ Operating Voltage Range: 2.2V to 18V
- ❑ CMOS Device for Optimal Stability
- ❑ Chopper Stabilized: No Amplifier Offset Voltage
- ❑ Activate With Commercially Available Permanent Magnets
- ❑ Thin, High Reliability SIP Package
- ❑ Solid State Switch with $I_{CC} = 20\text{mA}$

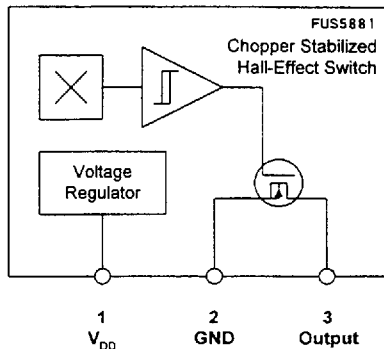

The FUS5881 Hall-Effect sensor IC family is designed in CMOS technology providing chopper stabilized amplifiers with switched capacitors. Therefore these magnetic field sensor devices have no amplifier offset voltage which in bipolar designed devices is the main reason for temperature sensitive output signal drift.

The sensors output transistor will be "Switched On" (B_{op}) in the presence of a sufficiently strong South-Pole magnetic field, facing the marked side of the SIP package. The sensor output will be "Switched Off state" (B_{np}) in the presence of a weaker South field and will remain off with "0" field.

The FUS5881 sensor family comes in four guaranteed temperature specifications to meet the needs of various commercial and industrial applications.

Typical applications for these devices are:

- Solid State Switch
- Limit switch
- Current limit
- Interuptor
- Current Sensing

Absolute Maximum Ratings FUS5881 Series

Characteristic	Symbol	Device	Rating	Unit
Power Supply Voltage	V_{DD}	All	20	V
Supply Current	I_{DD}	All	10	mA
Output Switch Current	I_{OUT}	All	20	mA
Power Dissipation	P_D	All	100	mW
Operating Ambient Temperature Range	T_A	FUS5881 US	0 ... +70	°C
		FUS5881 SUA	-20 ... +85	
		FUS5881 EUA	-40 ... +85	
Storage Temperature Range	T_S	All	-65 ... +150	°C