

PBL 385 71

High current Speech and Line interface Circuit

Description.

PBL 38571 is a monolithic integrated speech transmission circuit for use in electronic telephones and as DECT line interface with balanced in - and output. It is designed to accommodate either a low impedance dynamic microphone or an electret microphone that can be supplied from the circuit's own DC - supply. A signal summing point at the transmitter input is available. An internally preset line length compensation can be adjusted with external resistors to fit into different current feed systems as for ex. 48 V, 2 x 200 ohms, 48 V, 2 x 400 ohms and 48 V, 2 x 800 ohms. The line regulation can be shut off in low mode. Application dependent parameters such as line balance, side tone level, transmitter and receiver gains and frequency responses are set independently by external components which means an easy adaption to various market needs. The setting of the parameters, if carried out in certain order will counteract the interaction between the settings. It features high line current capability on a small footprint. Function compatible with the PBL 3781 family of speech circuits.

Key features.

- Minimum number of external components, 5 capacitors and 10 resistors.
- Easy adaption to various market needs.
- Mute control input for operation with DTMF - generator.
- Transmitter and receiver gain regulation for automatic loop loss compensation. Disconnectable.
- Extended current and voltage range 5 - 130 mA, down to 2 V.
- Differential microphone input for good balance to ground.
- Balanced receiver output stage.
- In 16 - pin DIP and SO BW batwing packages.
- Short start up time.
- Excellent RFI performance.

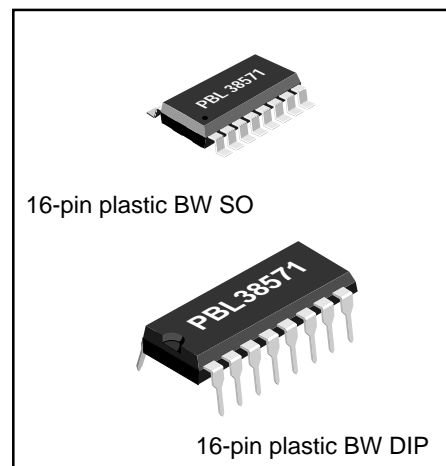
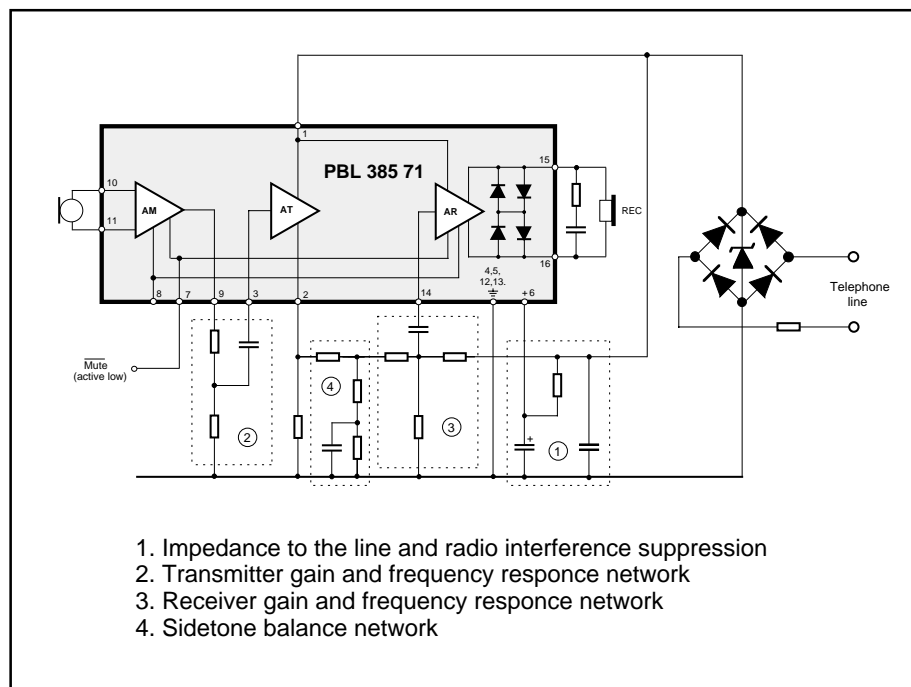

Figure 1. Functional diagram.

Maximum Ratings

Parameter	Symbol	Min	Max	Unit
Line voltage, $t_p = 2$ s	V_L	0	18	V
Line current, continuous, DIP (batwing) package	I_L	0	130	mA
Line current, continuous, SO (batwing) package (dependent on mounting)	I_L	0	120	mA
Operating temperature range	T_{Amb}	-40	+70	°C
Storage temperature range	T_{Stg}	-55	+125	°C

No input should be set on higher level than pin 6 (+C).

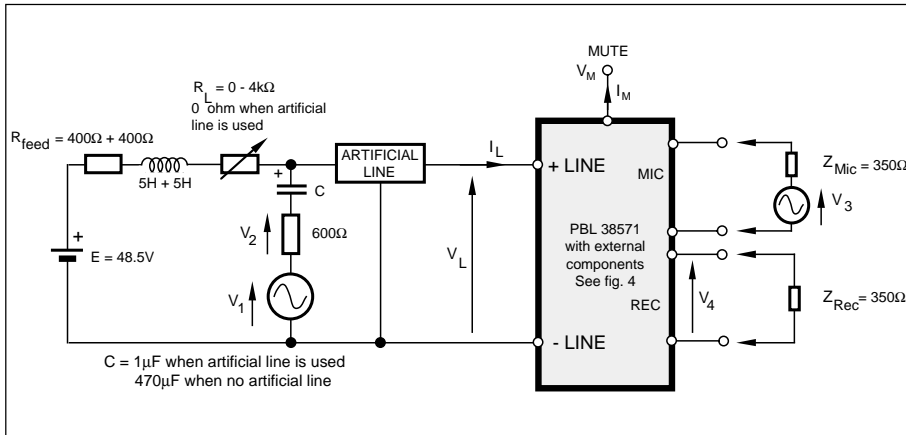

Figure 2. Test set up without rectifier bridge.

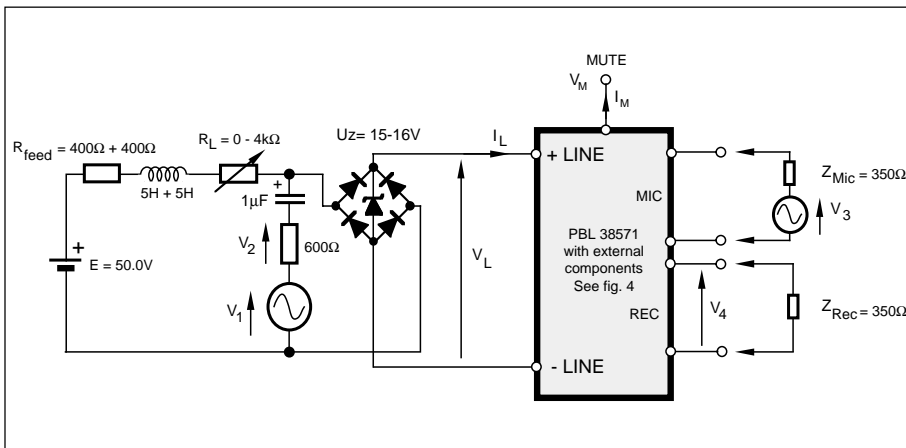

Figure 3. Test set up with rectifier bridge.

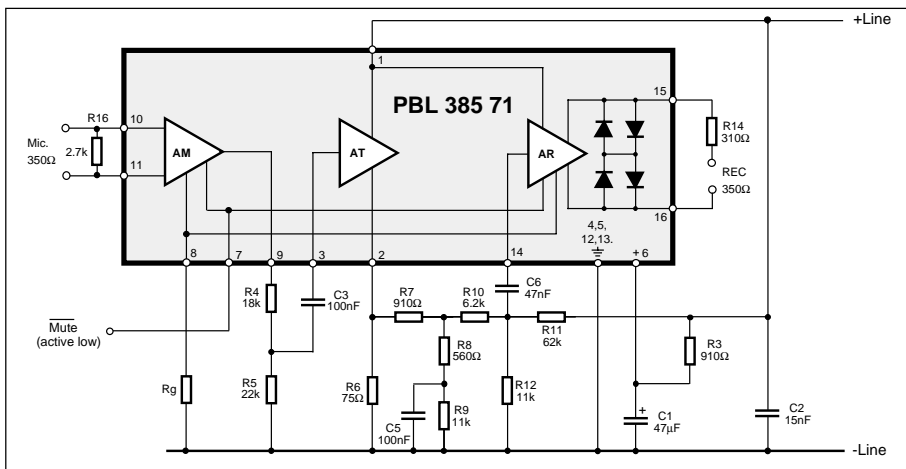

Figure 4. Circuit with external components for test set up.

Electrical Characteristics

At $T_{Amb} = +25^{\circ}C$. No cable and line rectifier unless otherwise specified.

Parameter	Ref. fig.	Conditions	Min	Typ	Max	Unit
Line voltage, V_L	2	$I_L = 15\text{ mA}$	3.3	3.7	4.1	V
	2	$I_L = 100\text{ mA}$	11	13	15	V
Transmitting gain, note 1 No gain regulation, low mode	2	$20 \cdot 10 \log (V_2 / V_3)$; 1 kHz $R_g = 20\text{ k}\Omega$	41	43	45	dB
Transmitting gain, note 1 With gain regulation	2	$20 \cdot 10 \log (V_2 / V_3)$; 1 kHz $R_L = 0, R_G = \infty$	41	43	45	dB
		$R_L = 400\ \Omega$	43.5	45.5	47.5	dB
		$R_L = 900\ \Omega - 2.2\ \text{k}\Omega$	46	48	50	dB
Transmitting range of regulation	2	1 kHz, $R_L = 0$ to $900\ \Omega$	3	5	7	dB
Transmitting frequency response	2	200 Hz to 3.4 kHz	-1		1	dB
Microphone input impedance	2		1.7/(2.7) note 3			k Ω
Transmitter input impedance pin 3	2	1 kHz	13.5	17	20.5	k Ω
Transmitter dynamic output	2	200 Hz - 3.4 kHz $\leq 2\%$ distortion, $I_L = 20 - 100\text{ mA}$		1.5		V_p
Transmitter max output	2	200 Hz - 3.4 kHz $I_L = 0 - 100\text{ mA}, V_3 = 0 - 1\text{ V}$		3		V_p
Transmitter output noise	2	Psoph-weighting, Rel 1 V_{rms} , $R_L = 0$		-75		dB _{Psoph}
Receiving gain, note 1 No gain regulation, low mode	2	$20 \cdot 10 \log (V_4 / V_1)$; 1 kHz $R_g^{TM} = 20\text{ k}\Omega$	-18.5	-16.5	-14.5	dB
Receiving gain, note 1 With gain regulation	2	$20 \cdot 10 \log (V_4 / V_1)$; 1 kHz $R_L = 0, R_G = \infty$	-18.5	-16.5	-14.5	dB
		$R_L = 400\ \Omega$	-16	-14	-12	dB
		$R_L = 900\ \Omega - 2.2\ \text{k}\Omega$	-13.5	-11.5	-9.5	dB
Receiving range of regulation	2	1 kHz, $R_L = 0$ to $900\ \Omega$	3	5	7	dB
Receiving frequency response	2	200 Hz to 3.4 kHz	-1		1	dB
Receiver input impedance	2	1 kHz,		38		k Ω
Receiver output impedance	2	1 kHz,		3(+310)note 3		Ω
Receiver dynamic output note 2	2	200 Hz - 3.4 kHz $\leq 2\%$ distortion, $I_L = 20 - 100\text{ mA}$		0.5		V_p
Receiver max. output	3	Measured with line rectifier 200 Hz - 3.4 kHz, $I_L = 0 - 100\text{ mA}$, $V_1 = 0 - 50\text{ V}$		0.9		V_p
Receiver output noise	2	A-weighting, Rel 1 V_{rms} , with cable 0 - 3 km, $\varnothing = 0.4\text{ mm}$ 0 - 5 km, $\varnothing = 0.5\text{ mm}$,		-85		dB _A
Mute input voltage at mute (active low) pin 7.	2				0.3	V

Notes

- Adjustable to both higher and lower values with external components.
- The dynamic output can be doubled, see applications information.
- External resistor in the test set up.

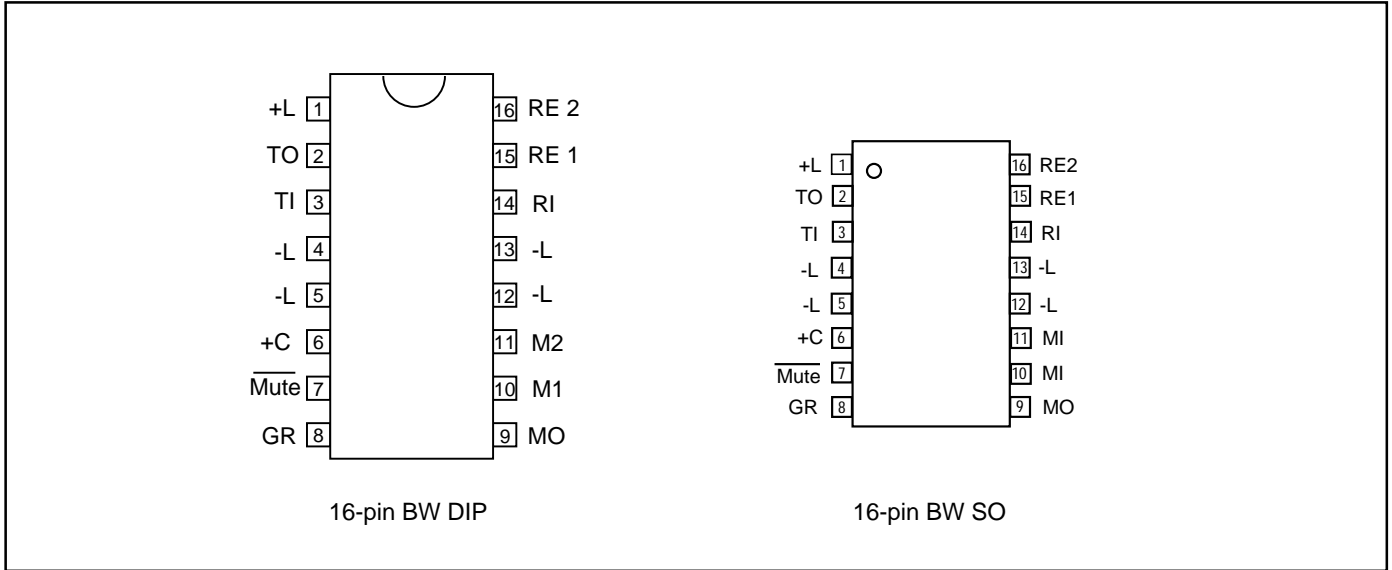

Figure 5. Pin configurations.

Pin Descriptions

Refer to figure 5.

Pin	Name	Function
1	+L	Output of the transmitter amplifier. Connected to the line through a polarity guard diode bridge.
2	TO	Output of the transmitter amplifier. Connected through a resistor of 47 to 100 ohm to -L, sets the DC-resistance of the circuit. The output has a low ac. impedance and the signal is used to drive a side tone balancing network.
3	TI	Input of transmitter amplifier. Input impedance 17 kohm \pm 20 %.
4,12 } 5,13 }	- L	Negative power terminal, connected to the line through a polarity guard diode bridge.
6	+C	Positive power supply terminal for most of the circuitry inside the PBL 385 71 (about 1 mA current consumption). The +C pin should be connected to a decoupling capacitor of 47 μ F to 150 μ F.
7	Mute	Mute input. Maximum voltage (to mute) is 0.3 V, current sink requirement of external driver is 100 μ A.
8	GR	Input for the gain regulation control circuitry.
9	MO	Output of the microphone amplifier.
10 } 11 }	MI 1 } MI 2 }	Inputs of the microphone amplifier. Input impedance 1.7 kohm \pm 20%.
14	RI	Input of receiver amplifier. Input impedance is 38 kohm \pm 20 %.
15 } 16 }	RE 1 } RE 2 }	Receiver amplifier outputs. Output impedance approximately 3 ohms.

Functional description

Design procedure; ref. to fig.4.

The design is made easier through that all settable parameters are returned to ground (-line), this feature differs it from bridge type solutions. To set the parameters in the following order will result in that the interaction between the same is minimized.

1. Set the circuit impedance to the line, either resistive (600Ω) or complex. ($R3$ and $C1$). $C1$ should be big enough to give low impedance compared with $R3$ in the telephone speech frequency band. Too large $C1$ will make the start-up slow. See fig. 6.

2. Set the DC-characteristic that is required in the PTT specification or in case of a system telephone, in the PBX specification ($R6$). There are also internal circuit dependent requirements like supply voltages etc.

3. Set the attac point where the line length regulation is supposed to cut in ($R1$ and $R2$ in fig. 18). Note that in some countries the line length regulation is not allowed. In most cases the end result is better and more readily achieved by using the line length regulation (line loss compensation) than without. See fig. 13.

4. Set the transmitter gain and frequency response.

5. Set the receiver gain and frequency response. See text how to limit the max. swing to the earphone.

6. Adjust the side tone balancing network.

7. Set the RFI suppression components in case necessary. In two piece telephones the often "helically" wound cord acts as an aerial. The microphone input with its high gain is especially sensitive.

8. Circuit protection. Apart from any other protection devices used in the design, a good practice is to connect a 15V 1W zener diode across the circuit, from pin 1 to -Line.

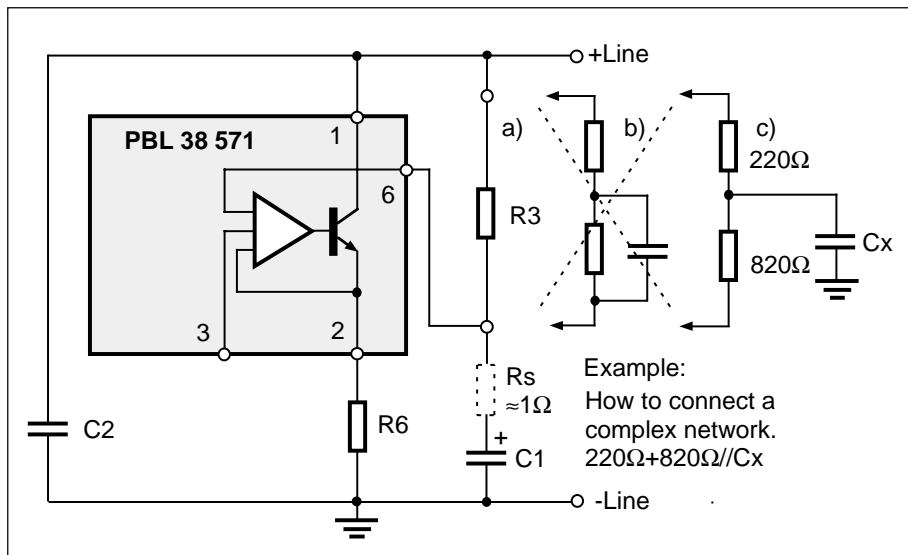

Figure 6. AC-impedance.

Impedance to the line

The AC- impedance to the line is set by $R3$, $C1$ and $C2$. Fig.4. The circuits relatively high parallel impedance will not influence it to any noticeable extent. At low frequencies the influence of $C1$ can not be neglected. Series resistance of $C1$ that is dependent on the temperature and the quality of the component will cause some of the line signal to enter pin 6. This generates a closed loop in the transmitter amplifier that in it's turn will create an active impedance thus lowering the impedance to the line. The impedance at high frequencies is set by $C2$ that also acts as a RFI suppressor.

In many specifications the impedance towards the line is specified as a complex network. See fig. 6. In case a). the error signal entering pin 6 is set by the ratio $\approx R_s/R_{19}$ (910Ω), where in case b). the ratio at high frequencies will be $R_s/220\Omega$ because the 820Ω resistor is

bypassed by a capacitor. To help up this situation the complex network capacitor is connected directly to ground, case c). making the ratio $R_s/220\Omega+820\Omega$ and thus lessening the error signal. Conclusion: Connect like in case c) when complex impedance is specified.

DC - characteristic

The DC - characteristic that a telephone set has to fulfill is mainly given by the network administrator. Following parameters are useful to know when the DC behaviour of the telephone is to be set:

- The voltage of the feeding system
- The line feeding resistance 2 x..... ohms.
- The maximum current from the line at zero line length.
- The min. current at which the telephone has to work (basic function).
- The lowest and highest voltage permissible across the telephone set.
- The highest voltage that the telephone may have at different line currents. Normally set by the network owners specification. The lowest voltage for the telephone is normally set by the voltages that are needed for the different parts of the telephone to function. For ex. for transmitter output amplifier, receiver output amplifier, dialler, speech switching.

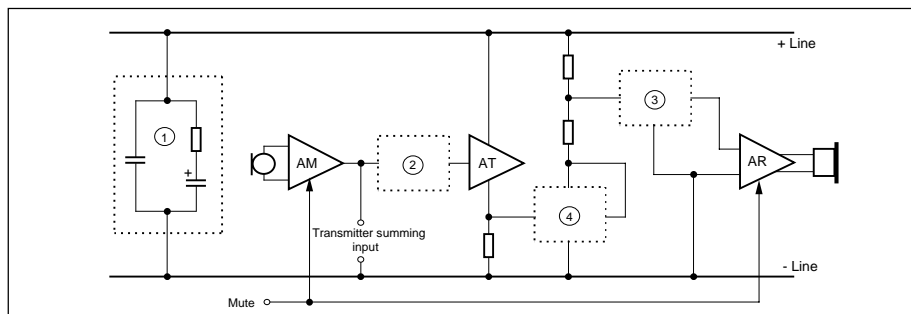

Figure 7. Block connections.

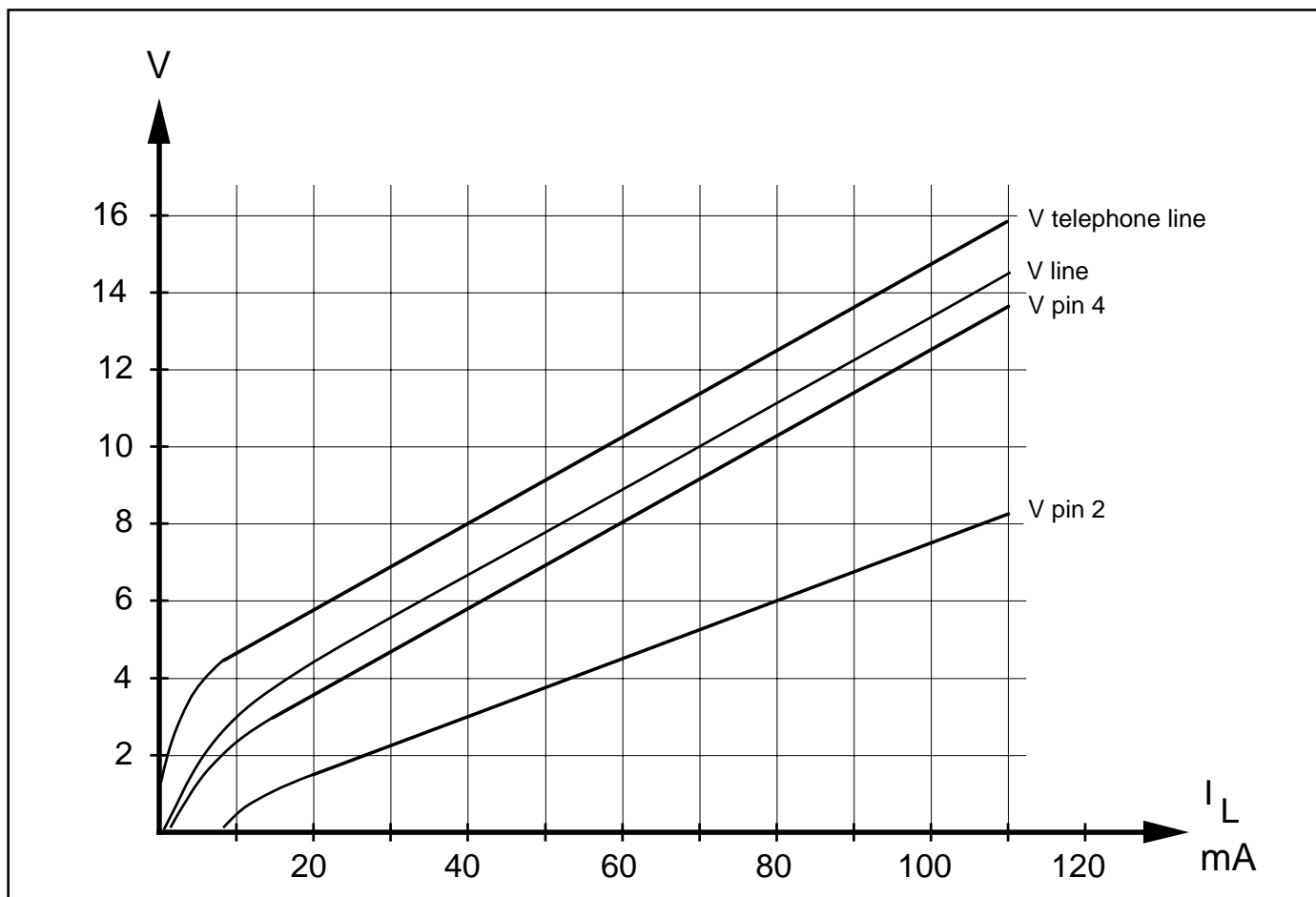

Figure 8. DC - Characteristics. ($R6 = 75\Omega$)

$R6$ will set the slope of the DC-char. and the rest of the level is set by some constants in the circuit as shown in the equation below. The slope of the DC-char. will also influence the line length regulation (when used) and thus the gain of both transmitter and receiver. See the table under gain regulation. $R6$ also acts as power protection for the circuit, this must be kept in mind when low values of $R6$ are considered.

$$V_{Line} \approx 2 + 1.5 \cdot R6 \cdot I_{line}$$

$$V_{telephoneline} \approx 1.5 V + V_{line}$$

Microphone amplifier

The microphone amplifier in PBL38571 is divided into two stages. The first stage is a true differential amplifier providing high CMRR (-55 to -65 dB typical) with voltage gain of 19 dB. This stage is followed by a gain regulated amplifier with a regulation range of 5 ± 2 dB. The input of the

microphone amplifier can be used for dynamic or electret transducers. See fig. 10. An electret microphone with a built in FET amplifier is to be seen from outside as a high impedance constant current generator and is normally specified with a load resistance of $\approx 2k$. This is to be considered as max. value and by using it will render the max. gain from the microphone. This level of input signal that is unnecessary high will result in clipping in the microphone amplifier and could in mute condition permeate through the input to the circuits reference and this way to all functions, resulting among other things in a bad mute. Hence it is better regarding noise performance and mute to rather use the gain of the microphone amplifier than the gain of the microphone itself (in case of electret) flat out. A more suitable level of gain from the microphone is achieved by using a load resistance of 330 - 820 Ω . A low microphone impedance will also improve RFI suppression. Gain setting to the line is done at the input of the transmitter. The microphone amplifier has its own

temperature stable reference to prevent overhearing to other parts and functions on the chip. It is possible to use the microphone amplifier as a limiter (added) to the limiter in the transmitter output stage of the transmitted signal. See fig.9. The positive output swing is then limited by the peak output current of the microphone amplifier. The negative swing is limited by the saturation voltage of the output amplifier. The output of the amplifier is DC-vice at internal reference level (1.2V). The lowest negative level for the signal is reference minus one diode and saturated transistor drop. ($1.2 - 0.6 - 0.1 = 0.5V$) The correct clipping level is found by determining the composite AC- and DC-load that gives a maximum symmetrical unclipped signal at the output. This signal is then fed into the transmitter amplifier at a level that renders a symmetrical signal clipping on the line. (adjust with ratio $R4, R5$) The total transmitter gain when an electret microphone is used can then be adjusted with the load resistor of the electret microphones buffer amplifier.

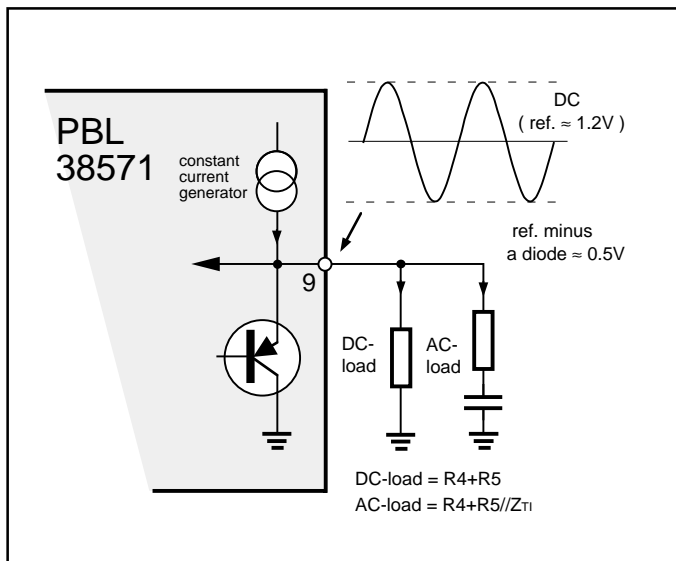

Figure 9. Microphone amplifier output clipping.

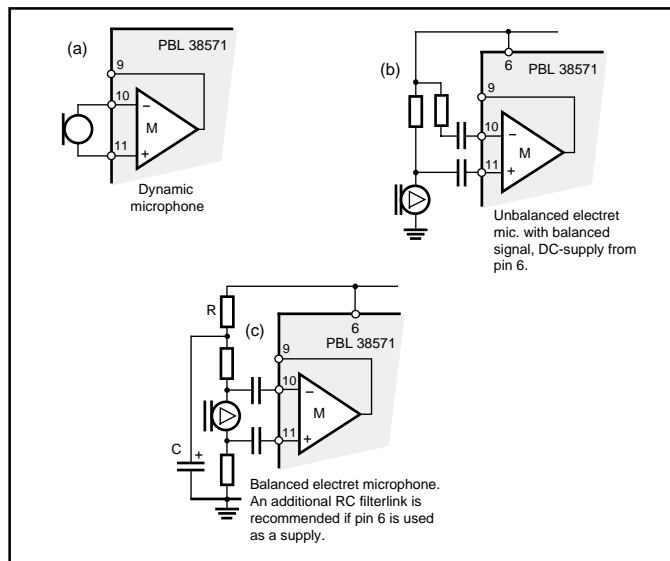

Figure 10. Microphone solutions.

Transmitter amplifier

The transmitter amplifier in PBL38571 consists of three stages. The first stage is an amplitude limiter for the input signal at TI, in order to prevent the transmitted signal to exceed a certain set level and cause distortion. The second stage amplifies further the signal from the first and adds it to a DC level from an internal DC-regulation loop in order to give the required DC characteristic to the telephone set. The output of this stage is TO. The third stage is a current generator that presents a high impedance towards the line and has its gain from TO to +L. The gain of this amplifier is Z_L/R_6 where Z_L is the impedance across the telephone line. Hence, the absolute maximum signal amplitude that can be transmitted to the line undistorted is dependent of R_6 . (amplitude limiting)

The transmitter gain and frequency response is set by the RC-network between the pins 9 and 3. See fig.11. The capacitor for cutting the high end of frequency band is best to be placed directly at the microphone where it also will act as a RFI suppressor. The input signal source impedance to the transmitter amplifier input TI should be reasonably low in order to keep the gain spread down, saying that R_4/R_5 (see fig. 4) must be at least a factor 5 lower than the Z_{Tin} . Observe that the capacitor C_1 should have a reasonably good temperature behaviour in order to keep the impedance rather constant. The $V+C$'s influence on the transmitter DC-characteristic is shown in the fig.8 (DC-characteristic), therefore the transmitter gain would change if the transmitted signal gives reason to an ac-voltage leak signal across C_1 since this is a feedback point. If the transmitter has an unacceptable low swing to the line at low line currents $< \approx 10mA$ the first step should be to examine if the circuits DC characteristic can be adjusted upwards.

How to calculate the gains in the transmitter channel.

See fig. 2 and 4.

Microphone amplifiers first stage 19 dB.

Microphone amplifiers regulated second stage 10.5 dB - 15.5 dB

Regulation interval 10.5 - 15.5 dB

low gain 19.0 + 10.5 dB = 29.5 dB

high gain 19.0 + 15.5 dB = 34.5 dB

$$\frac{V_2}{V_3} = \frac{R_M}{Z_{mic} + R_M} \cdot G_M \cdot \frac{R_5}{R_4 + R_5} \cdot G_{TX} \cdot \frac{R_{load}}{R_6}$$

R_M = Microphone amplifier input resistance

$R_{load} = R_{line} // R_{telephone}$

ex. calculate the gain of the transmitter stage G_{TX} at 0 - line length:

$$43 = 20 \log\left(\frac{(1.7 / 2.7)k}{350\Omega + (1.7 / 2.7)k}\right) + 29.5 + 20 \log\left(\frac{(17 / 22)k}{18k + (17 / 22)k}\right) + G_{TX} + 20 \log\left(\frac{600\Omega // 910\Omega}{75\Omega}\right)$$

$$43 = -2.51 + 29.5 - 9.17 + G_{TX} + 13.66$$

$$G_{TX} = 11.52 dB$$

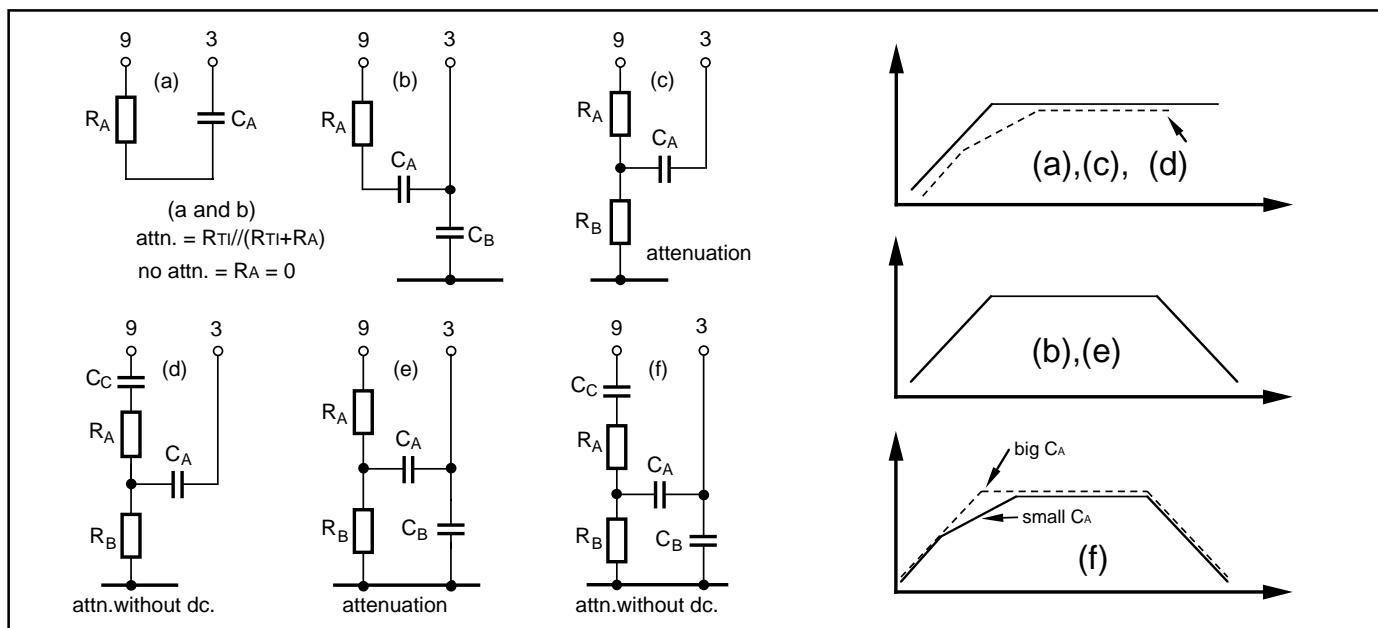

Figure 11. Possible network types between microphone amplifier and transmitter.

Receiver amplifier

The receiver amplifier consists of three stages, the first stage being an input buffer that renders the input a high impedance. The second stage is a gain regulated differential amplifier and the third stage a balanced power amplifier. The power amplifier has a differential output with low DC- offset voltage, therefore a series capacitor with the load is normally not necessary. The receiver amplifier uses at max. swing 4-6 mA peak. This current is drawn from the +Line. The driving capacity of the power stage can be optimized by connecting a resistor in series with the earphone itself (fig.12 b.). The gain and frequency response is set at the input RI with a RC-network. The receiver gain can be regulated. The range of regulation from the input to the output is 5 ± 2 dB (19 to 24dB). The balanced earphone amplifier can not be loaded to full (both current and

signal level) single ended. The signal would be distorted when returned to ground. A method is shown in fig.12 d. how to connect a light load (5k ac. or DC wise) to the output. It is preferred that both outputs are loaded the same. The receiver has, as a principal protection, two series diodes anti parallel across its output to limit the signal to the earphone and thus preventing an acoustical shock. A resistor in

series with the output can very well be used to increase the protection level. Note, that the noise in the receiver is always transmitter noise that has been more or less well balanced out by the side tone network.

The RC - network (optional) at the output is to stabilize against the inductive load that an earphone represents.

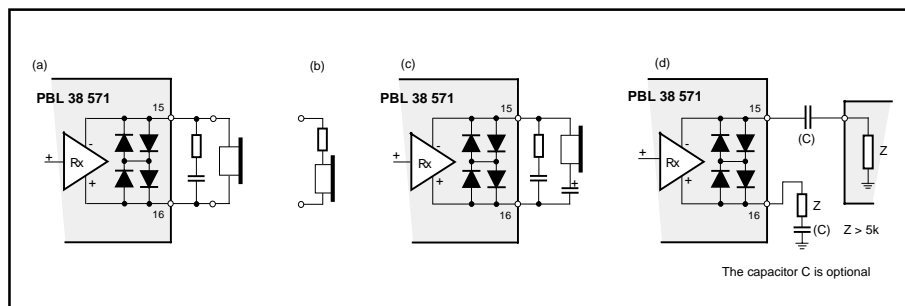

Figure 12. Receiver arrangements.

Gain regulation.

Both the receiver and transmitter are gain regulated (line loss compensated). There is a fixed default compensation on the chip that can be adjusted or set to constant low gain mode. The input impedance at the gain regulation pin 8 is $5.5k \pm 20\%$. The default regulation pattern is valid when the input is left open. Fig. 13 shows a typical transmitter or receiver

gain pattern versus line length. The following will show, what to alter, to change the look of the curve.

a). Adjustable with the divider R4,R5 for the transmitter and with R12 for the receiver.

b). The attack point of the regulator is adjusted with the divider R1,R2 (fig. 18) to either direction, up or down, on the line current axis.

c). The angle of elevation of the curve is mainly set by the value of R6. If the DC-characteristics is set according to the line parameters and a correct value for R6 is chosen the angle is mostly correct but it can be adjusted with R6. The adjustment will affect the DC-characteristics as well as most of the other parameters. This is why the DC- characteristic is set early in the design phase.

Battery feed	R1	R2	R6
Regulation:			
48V, 2 • 200Ω	}	∞	47Ω
		450k	75Ω
48V, 2 • 400Ω		∞	75Ω
48V, 2 • 800Ω	Sweden, apply for spec. application.		
No regulation:			
All feedings:			
Set for low gain	∞	22k	47 - 75Ω
Set for high gain	75k	∞	47 - 75Ω

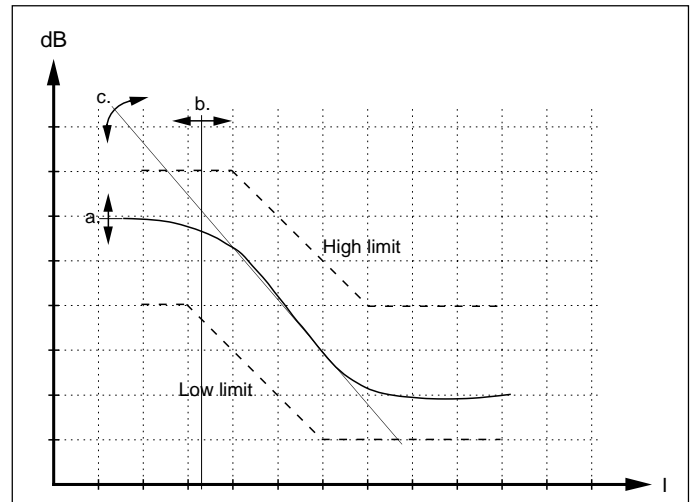

Figure 13. Gain regulation principle.

What is balancing the side tone?

To understand that side tone balancing is to counteract the signal, that is transmitted via the microphone and transmitter to the line, returning to the earphone via the receiver.

That presence of a strong side tone signal is disturbing in a way that one quite instinctively lowers ones own voice level thus lowering the signal level for the other party. But again, if the balance is too good (seldom the case) the earphone will feel "dead". In practical terms what is expected is the same amplitude of ones own voice in the ear as when not talking in a telephone. The need to lower the side tone level

where no balancing has been done is in the order of 6 - 12 dB.

To understand that the side tone is influenced by other factors like, the impedance of the line and the signal that enters the ear acoustically directly from the mouth and from the mouth through the material in the handset. The signal that enters the microphone from the earphone acoustically will also influence the return loss factor to the telephone line.

To understand that the side tone network can be trimmed to form a veritable "distortion analyser", so that the distortion that is present from the microphone, will be the only signal entering the earphone and this signal even being small will sound very bad. It is better to induce some of the fundamental frequency back by making

the balance less perfect at that frequency. This is valid for a network that is trimmed to only one frequency. It is to strive to trim the network such that it will attenuate the fundamental and the harmonic frequencies alike throughout the different line combinations.

To understand that if one of the two signals entering the balancing system from either direction, direct from microphone or via the line, is clipped, will result in a very distorted signal entering the receiver amplifier and thus the earphone. Further, to remember that side tone is a small signal that is the difference of two large signals and that the amplitude of the distortion can be up to ten times the amplitude of the fundamental frequency.

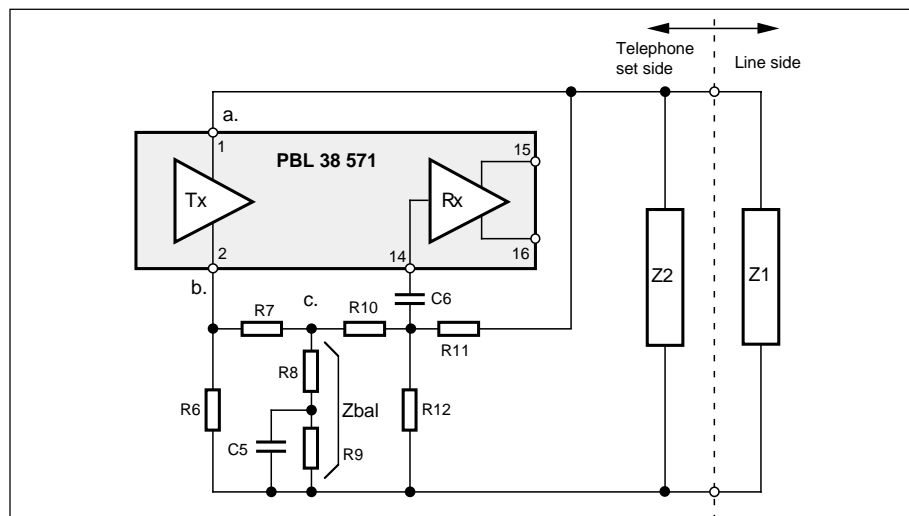

Figure 14. The side tone suppression principle.

A short guidance for understanding the side tone principle. (See fig.14.)

Assuming the line impedance to be 600Ω. (theoretical value)
 Z1 = Line impedance
 Z2 = The telephone set impedance 600Ω
 $Z1//Z2 = 300\Omega$
 R6 will have a certain value 39 - 100Ω to give the telephone a specified DC-characteristic and overcurrent protection. Assuming that this DC-characteristic requires $R6=60\Omega$, hence it will be 1/5 of the $Z1//Z2$. This will in transmitting mode result that 1/5 of the ac-signal that is on the line appear across R6.

Note that the signals at points a. and b. are 180 degrees off phase.

$10 \times R6 \approx R7 + Zbal$ Note #1
 $R7 \approx Zbal$ Note#2

The ac-signal at point c. is now 1/10 of the signal on the line because it is further divided by two from point b. ($R7 \approx Zbal$). Hence $10 \times R10 \approx R11$ to satisfy the balancing criteria. R12 is to set the receiver gain. (can also be a volume control potentiometer).

Note #1 These values ensure that the frequency behaviour of the transmitter is not influenced. With the ratio 1/10 the influence is 1 dB, and with ratio 1/20 it's 0.5 dB.

Note #2 If the R7 is made low ohmic compared with Zbal, it will load the latter and result in a bad side tone performance, again if the R7 is made high ohmic compared with Zbal will result in a low signal to balance the side tone with and make the balancing difficult. Making any of the impedances unnecessary high will make the circuit sensitive to RFI. All values given here are approximate and serve as starting entities only. The final trimming of side tone network is a cut and try proposition because a part of the balance lies in the acoustical path between the microphone and earphone.

Reverse side tone network.

This type of side tone balancing will help when for some reason there is a need to make the R6 low $< 47\Omega$ and thus the signal for balancing gets small across R6. By placing the balancing network like shown in fig.15 the possible signal level is 6 dB higher than in the first case and it will also help in case when a volume control is added to the receiver.

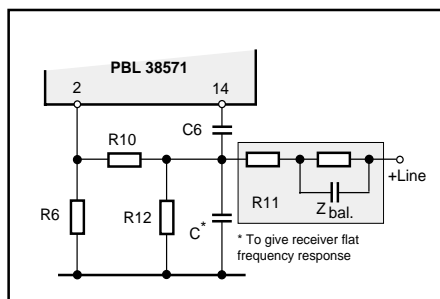

Figure 15. Reverse side tone network with complex R11.

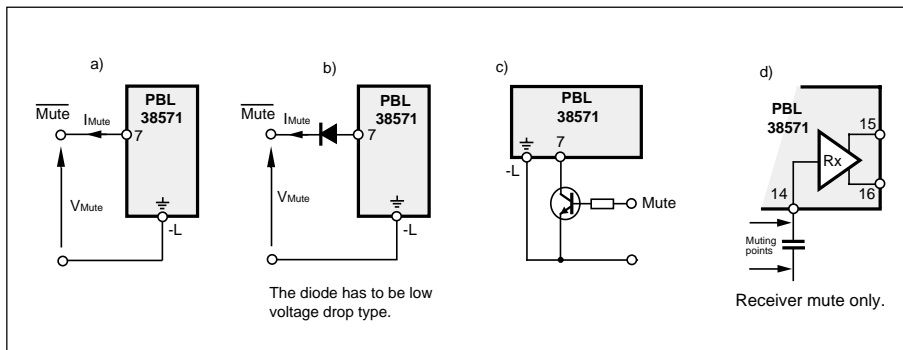

Figure 16. Mute input.

Mute function.

The circuit has a mute function at pin 7. Sinking current from this pin will cut off the gain in the microphone amplifier (attenuation min. 60dB) and decrease the gain in the receiver amplifier to reach the confidence tone level at DTMF-dialling. The receiver mute is ≈ 40 dB down from the unmuted value to satisfy those who keep the handset close to the ear at dialling.

Optional conditions:

For users who keep the handset from the ear, the confidence tone level is too low. To alter the level, a signal can be taken from DTMF generator output to receiver input before the capacitor C6. The added impedance to this point will hardly disturb the signal condition in active speech mode. The microphone amplifier only, can be muted by sinking current from the output pin 9. See fig. 4 or 9.

Figure 15 b.) If the system mute signal is used to other tasks than muting the speech circuit it has to be isolated. If a diode is used it has to be a low voltage drop type. The input at mute has to be below 300mV. If the mute signal has reverse polarity out of the system it can be phase changed like in c.) In case it is required to mute the receiver only, d.) it can be done by shorting the receiver input to ground before or after the input capacitor. Shorting the input pin to ground (does not have to be absolute ground) actuates a mute by driving the amplifier into saturation thus blocking the signal path and rendering a mute with high attenuation but will cause a DC-level shift at output which in its turn will cause a "click" in the earphone. This can be softened with a slower mute signal flank. If the second approach, grounding before the input capacitor is chosen, the grounding has to be low ohmic in order to render a high attenuating mute.

Start up circuit

The circuit contains a start up device which function is to fast charge capacitor C1 when the circuit goes into hook-off condition. The fast charge circuit is a thyristor function between pins 1 and 6 that will stop conducting when the current drain at pin 6 is lower than $\approx 700 \mu A$ + the internal current consumption (about 1 mA). Care must be taken when connecting external load to pin 6 in order not to exceed the $\approx 700 \mu A$ limit. Should this happen, it would result in an inoperative speech funktion. This circuit can not retrigger before the voltage level at C1 drops below 2V or the line voltage is below 1V. See fig. 17.

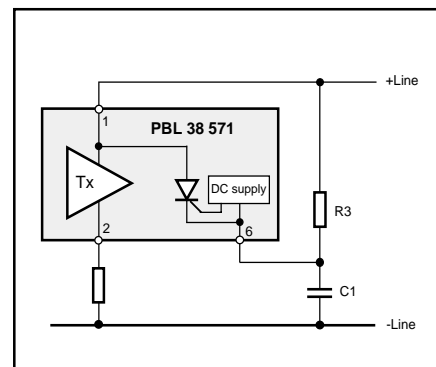

Figure 17. Fast startup circuit.

Power supply V_{+C} . (See fig.18)

PBL 385 71 generates its own DC supply V_{+C} dependent of line current with an internal shunt regulator. This regulator senses the line voltage V_L via R_3 and line current via R_6 in order to set the correct V_{+C} so the circuit can generate the required DC characteristic for a given line resistance R_{Line} and the line feeding data of the exchange. A decoupling capacitor is needed between pins +C and -L. The V_{+C} supply changes its voltage linearly with the

line current. It can be used to feed an electret microphone. Caution must be taken though not to drain too much current out of this output because it will affect the internal quick start circuit by locking itself into active state. (max. permissible current drain $700\mu A$)

Care has to be taken when deciding the resistance value of R_3 . See fig.6. All resistances that are applied from +Line to ground (-Line) will be in parallel, forming the real impedance towards the line. This will sometimes result in, that the ohmic value of R_3 is increased in order to comply

to the impedance specification towards the line. The speech circuit sinks $\approx 1mA$ into pin 6, which means that the working voltage for the speech function V_{+} will decrease with increasing R_3 , thus starving in the end the circuit of its working voltage. This dependency is often falsely taken as a sign of that the circuit does not work down to the low line current specified, but in fact it is the working voltage at pin 6 that has become too low. It is obvious that this problem is also connected into what kind of DC-characteristic is set. See fig. 8.

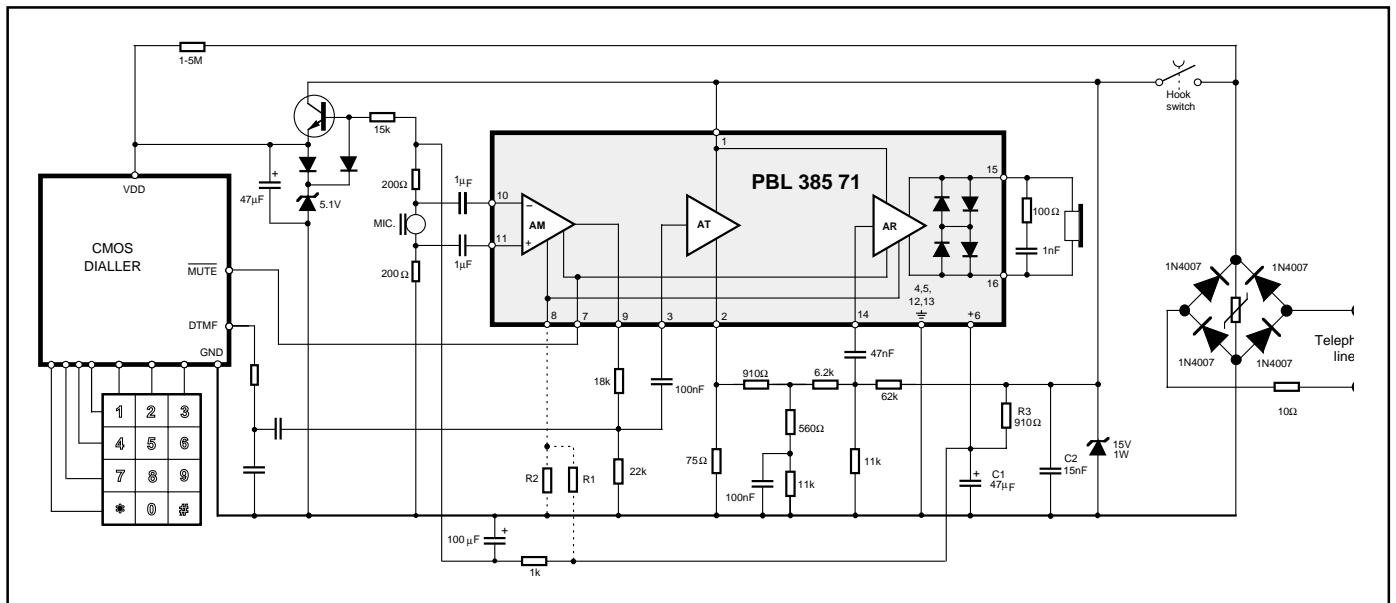

Figure 18. Typical standard DTMF dialling telephone application.

Short about Radio Frequency Interference RFI.

HF suppression at the microphone input.

The HF-signal at the microphone input can be seen composed as of two components. One component being the differential (between pins 10 and 11) and the second related to ground at pin 4. Of these two, the first is the most serious, entering the

amplifier directly being amplified and detected. The second component is less serious because it affecting both inputs alike and most of it will be balanced out of the amplifier. There might be the case where the HF-signal will have such an amplitude that the amplifier can not balance it out. Then components must be filtered with capacitors and maybe resistors. It is extremely important that everything that is done at the input is in balance, otherways the problem might get worse instead of better. The extreme balance requirement

goes all the way to the PCB-layout. Small unbalance signals can be corrected with capacitors marked with*) this requiring high precision components. See fig.19a. The solution shown is rather expensive but with precision components it renders good filtering at the input. If the main problem is the signal between the inputs, try to increase the 1nF capacitor but make the others procentually smaller in order to maintain the frequency response. A more simple solution, that is sufficient in most of the cases is also shown in fig. 19b.

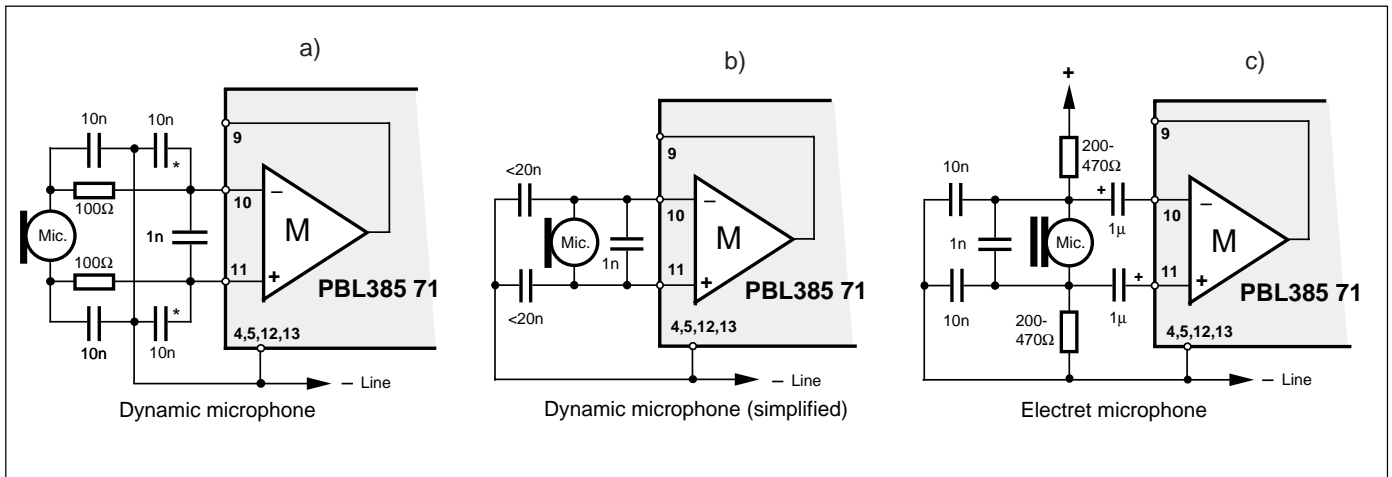

Figure 19. RFI elimination at microphone amplifier input.

HF-suppression at the receiver output.

The problem here is of the same kind as at the microphone amplifier input but will be easier to solve because of the much lower impedance and level of gain. The solution is shown in the fig. 20. No capacitors should be connected directly from pins 17 or 18 to ground because of the low output impedance, series resistance of at least 10Ω must be used if there is a tendency to self oscillation.

Other paths for the HF-signal to enter the audible system.

To find out if the problem originates in the DTMF-generator disconnect the generator and disconnect the mute input at pin 14. If the problem is small try to connect a capacitor from mute input to -line pin 14. DTMF circuits are sensitive to RFI because of their high impedance at the input pins, especially the keyboard inputs. These inputs are not possible to filter with large capacitors because of the keyboard scan-

ning pulses (1μs) that will be loaded down. To shield the keyboard will some times help. The polarity guard bridge can also act as a rectifier and demodulator, of the HF-signals. Connect 1nF capacitors across each diode in the bridge. There is a capacitor across the line C10, this is for RFI suppression but also to stabilise the whole system.

The capacitor C10 should be connected like in figure 22. The frequencies at which the RFI comes through are in the region of 10-1000MHz. The resistance of the C10 will be somewhere 0.01-10Ω hence even the shortest length of connector on the PCB board or wire will be in the same region of resistance and thus of greatest of importance. These actions described above should, when applied correctly, take care of the RFI coming in from the telephone line. The second way for the RFI to enter the system is to penetrate the PCB board capacitively. The test methode is to place a metal sheet under the telephone set to be tested and inject the sheet with RF signal. The most used and effective counter

measure to this kind of RFI penetration is to shield the telephone set, at least the bottom of it, that is closest to the main PCB board by metal foil or by spraying the plastic casing with metallic matter. See figure 21. This methode does not necessarily count out the RFI components that are recommended earlier.

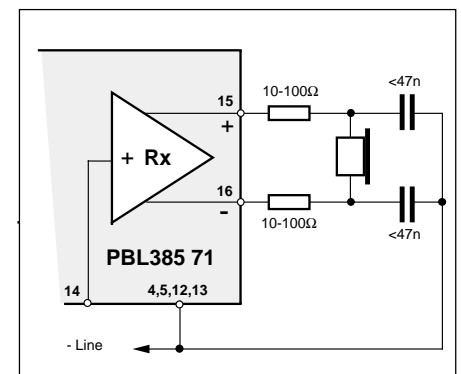

Figure 20. RFI elimination at receiver amplifier output

Radio interference originating from mobile phones

The problem with direct radiated RFI has accentuated lately because of the growing numbers of mobile and especially pocket telephones. Thus it is today rather common that a RF transmitter with output power of several watts in form of a mobile telephone is placed quite close to an analog telephone. There is a simultaneous even bigger problem coming from these portable phones of digital time-multiplex type like the GSM. The GSM signal consists of 900 MHz carrier that is transmitted in short signal bursts 1/8 of time and with a repetition frequency of slightly higher than 200 Hz. This signal will be directly radiated to all parts in a conventional telephone set. All unlinear elements as most of the semiconductors will envelope detect this signal and thus feed the 200 Hz signal with harmonics into all points of the telephone. The methode to counteract this problem is the same as before with a difference that it has to be done with much more precision. The principle is to attenuate the HF signal to a level where the detected 200 Hz signal is below a disturbing level especially at high sensitive points like at the microphone input.

Following aspects ought to be considered:

- 1). Do not make any points in the circuitry more high impede than necessary.
- 2). Keep all cables, wires and tracks on PC-board as short as possible.
- 3). Decouple all sensitive points to an internal ground with capacitors especially the microphone amplifier input.
- 4). To include series elements like resistors and inductors in all long wires or cables that could act as aerials. For ex. microphone cable, earphone cable, cable to the telephone network, mute wire and cable to the keypad.
- 5). Comprehend that it is a question of a HF- design, so that all used decoupling components are well suited to the frequencies at hand. (up to several GHz).
- 6). HF- design includes also that tracks on the PC-board act as inductors and therefore it is the more important that the decoupling capacitors are placed directly between the actual points and not

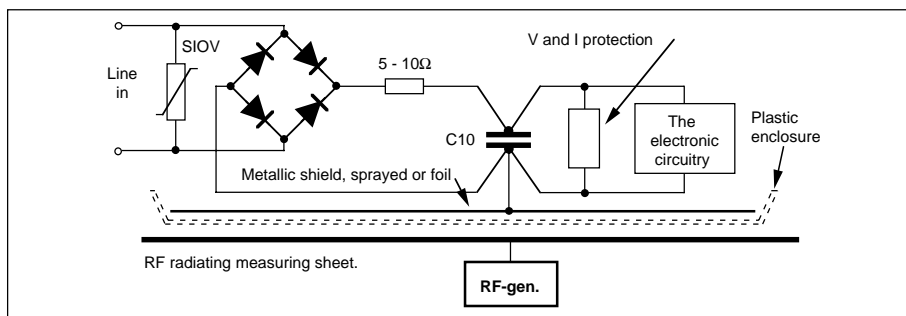

Figure 21. How to measure the RFI pickup.

- 7). Balanced points like a differential microphone input may have to be decoupled differentially between the inputs and "common mode" to common ground each input separately.
- 8). A virtual ground may have to be created into which all outgoing cables are decoupled in order to bypass the RF- signal. See fig. 31.
- 9). Think that even overvoltage and overcurrent protectors can be acting as HF detectors.
- 10). Shields that are connected to the internal ground can be of help.
- 11). Control that no already detected signals from for ex. dialler enter the speech circuit via the mute function.
- 12). Try to reach a high packing density on the PC-board.
- 13). Connect components as close to the IC as possible. Connect especially decoupling capacitors close to the ground pin of the IC.

The terminal circuits from Ericsson Components are manufactured in IC processes with large internal capacitors on the chip to counteract RFI disturbances in every possible way.

The simplest method to test the susceptibility of an apparatus to RFI is to take a portable phone of an actual type and move it transmitting across the phone, cables and handset. Measure the signal at earphone output as well as on the line.

Finally; to design an ordinary analog telephone to fulfill today's requirements is not a low frequency but a high frequency task.

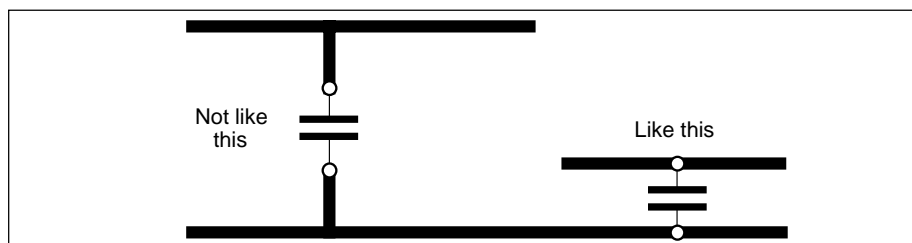

Figure 22. RFI elimination at PCB layout level.

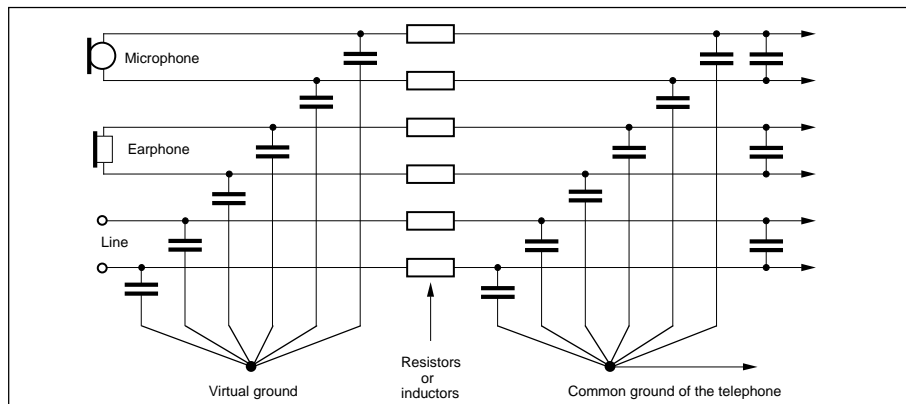

Figure 23. RFI elimination in the wiring.

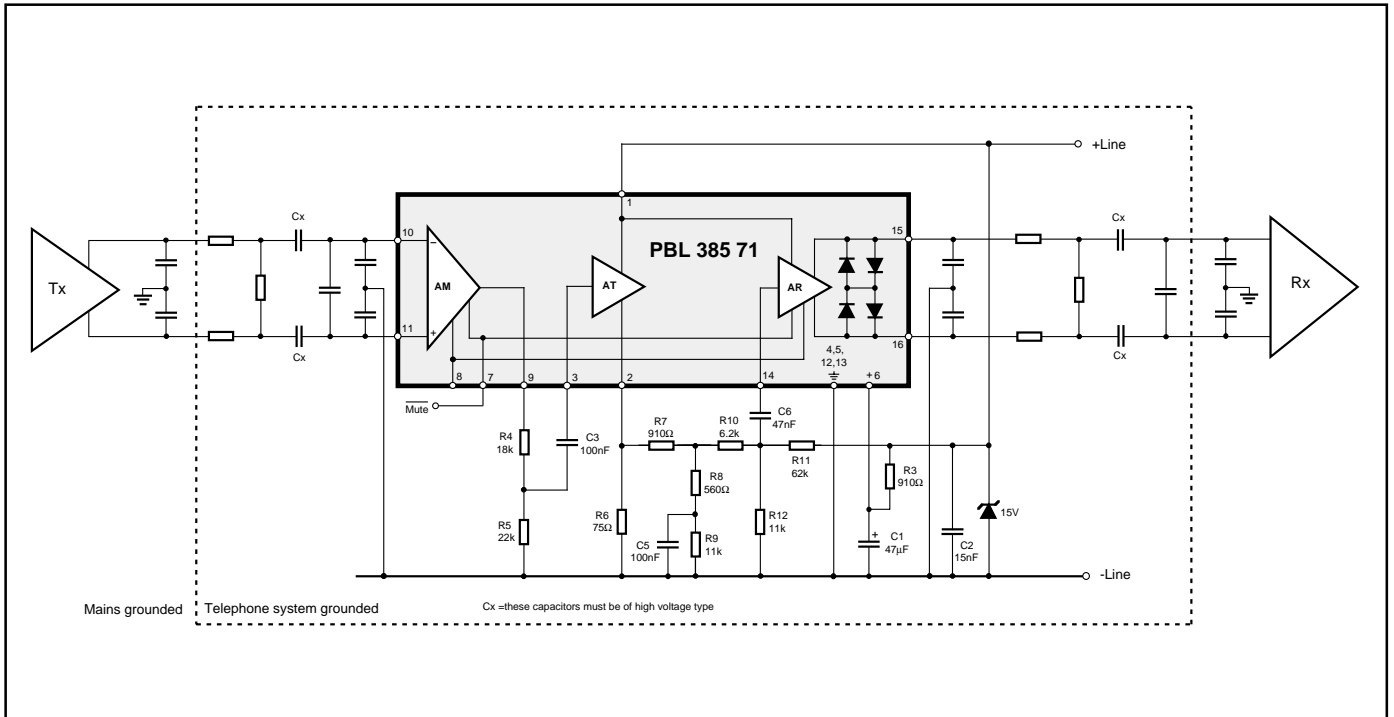

Figure 24. Principal balanced solution for a transformerless line interface that can be used in case of two different ground systems with low disturbance levels.

Information given in this data sheet is believed to be accurate and reliable. However no responsibility is assumed for the consequences of its use nor for any infringement of patents or other rights of third parties which may result from its use. No license is granted by implication or otherwise under any patent or patent rights of Ericsson Components. These products are sold only according to Ericsson Components' general conditions of sale, unless otherwise confirmed in writing.

Specifications subject to change without notice.

1522-PBL385 71

© Ericsson Components AB

June 1999



Ericsson Components AB
 S-164 81 Kista-Stockholm, Sweden
 Telephone: +46 8 757 50 00

Ordering Information

Package	Temp. Range	Part No.
16-pin Plastic BW DIP	-40 to +70°C	PBL 385 71/1NS
16-pin Plastic BW SO	-40 to +70°C	PBL 385 71/1SOS