

HID Lamp Controller

FEATURES

- Regulates Lamp Power
- Compensates For Lamp Temperature
- Fixed Frequency Operation
- Current Mode Control
- Overcurrent Protected
- Overvoltage Shutdown
- Open and Short Protected
- High Current FET Drive Output
- Operates Over Wide Battery Voltage Range: 5V to 18V

DESCRIPTION

The UCC3305 integrates all of the functions required to control and drive one HID lamp. The UCC3305 is tailored to the demanding, fast turn-on requirements of automobile headlamps, but is also applicable to all other lighting applications where HID lamps are selected. HID lamps are ideal for any lighting applications that can benefit from very high efficiency, blue-white light color, small physical lamp size, and very long life.

The UCC3305 contains a complete current mode pulse width modulator, a lamp power regulator, lamp temperature compensation, and total fault protection. Lamp temperature compensation is critical for automobile headlamps, because without compensation, light output varies dramatically from a cold lamp to one that is fully warmed up.

The UCC2305 is tested for full performance with ambient temperature from -40°C to $+105^{\circ}\text{C}$ while the UCC3305 is tested with ambient temperature from 0°C to $+70^{\circ}\text{C}$. The UCC3305 is available in a 28 pin small-outline, surface mount plastic package (SOIC).

BLOCK DIAGRAM

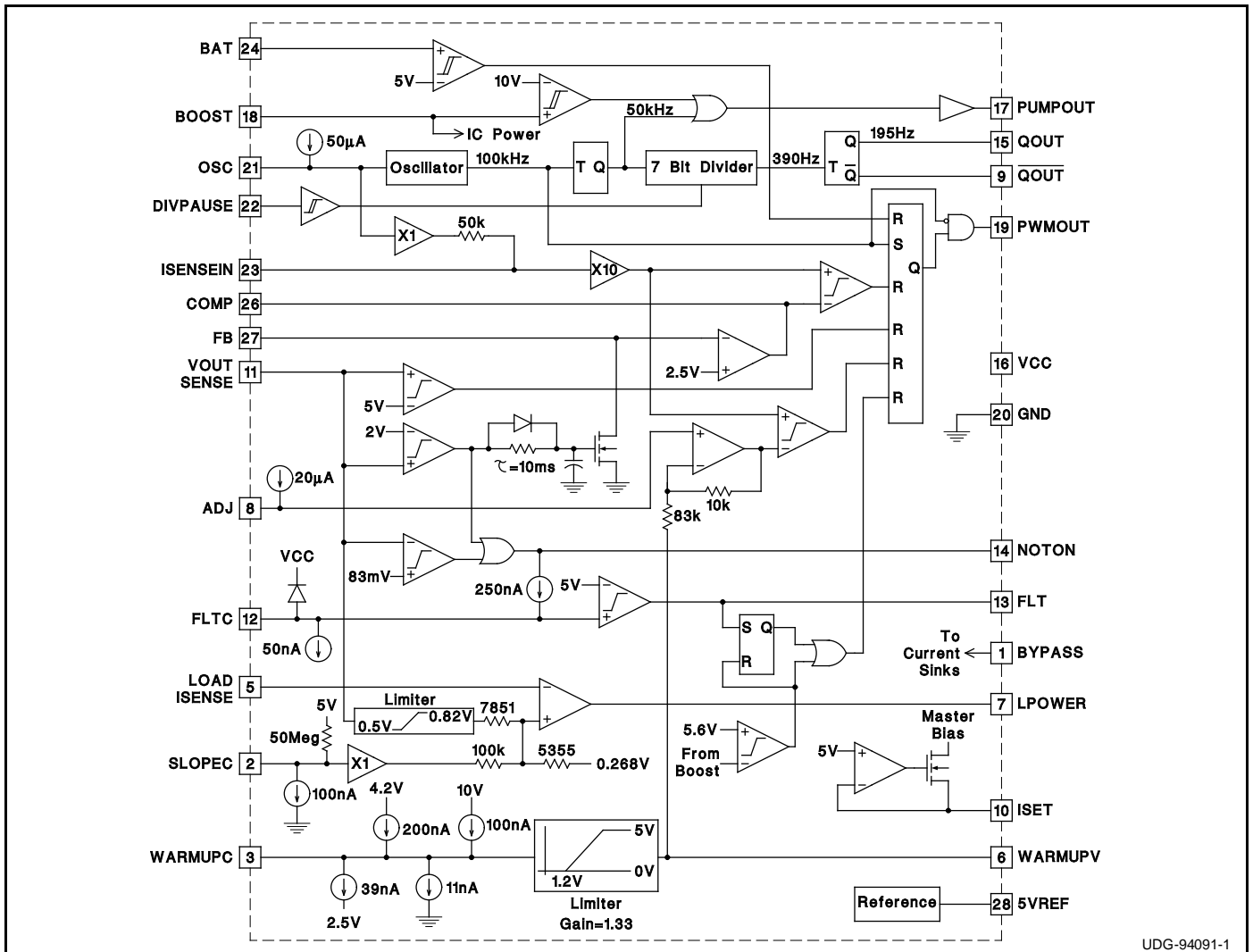

ABSOLUTE MAXIMUM RATINGS

VCC Supply Voltage	8.0V
BOOST Supply Voltage	12.0V
PWMOUT Current, Peak	±1.0A
PWMOUT Energy, Capacitive Load	5.0μJ
Input Voltage, Any Input	-0.3V to +10.0V
Output Current, QOUT, QOUT, FLT	±10.0mA
Output Current, 5VREF, LPOWER, COMP	±10.0mA
ISET Current	-1.0mA
Storage Temperature	-65°C to +150°C
Junction Temperature	-55°C to +150°C
Lead Temperature	+300°C

All voltages with respect to GND. Currents are positive into, negative out of the specified terminal. Consult Packaging Section of Databook for thermal limitations and considerations of packages.

CONNECTION DIAGRAM

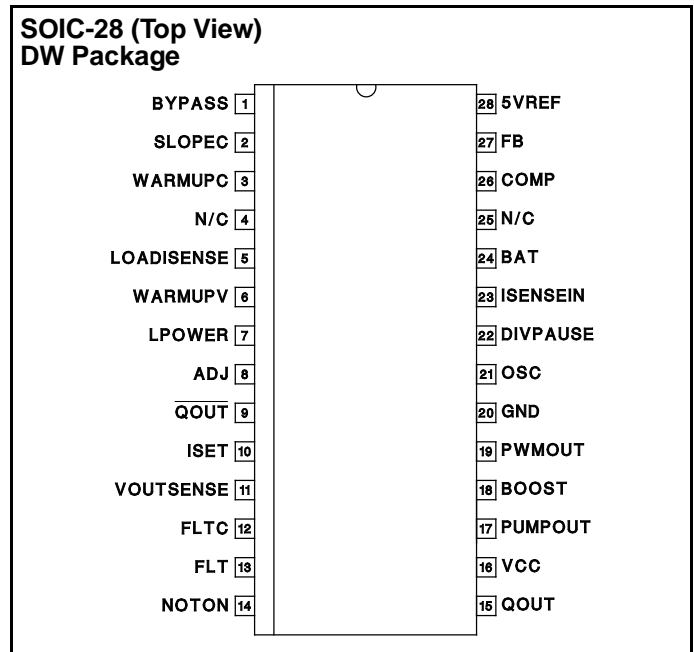

ELECTRICAL CHARACTERISTICS Unless otherwise stated, VCC = 6.6V, ISET = 100kΩ to GND, ADJ = 100kΩ to GND, OSC = 200pF to GND, BAT = 4V, LOADISENSE connected to LPOWER, VOUTSENSE = 0.666V, BOOST = 10.5V, COMP connected to FB through a 100kΩ resistor, -40°C < TA < +105°C for the UCC2305, 0°C < TA < +70°C for the UCC3305, and TA = TJ.

PARAMETER	TEST CONDITIONS	MIN.	TYP.	MAX.	UNITS
Overall Section					
VCC Supply Current			0.1	1.0	mA
BOOST Supply Current			3.0	5.0	mA
BOOST Threshold to PUMP Stop		9.1	9.6	10.1	V
BOOST Threshold to PUMP Start		9.2	9.7	10.2	V
BOOST Threshold to PWMOUT		5.1	5.6	6.1	V
Battery Section					
BAT Threshold to PWMOUT Stop		4.8	5.0	5.2	V
BAT Threshold to PWMOUT Start		4.25	4.8	5.0	V
BAT Input Current	BAT = 4V	-1		1	μA
Oscillator & Divider Section					
OSC Frequency		80	100	120	kHz
OSC Pull-Up Current	OSC = 1.5V	-70	-50	-40	μA
DIVPAUSE Threshold to Pause		1.2	1.5	1.8	V
DIVPAUSE Threshold to Divide		0.9	1.2	1.5	V
DIVPAUSE Input Current	0V < DIVPAUSE < 6V	-8	-5	-2	μA
Reference Section					
5VREF Voltage		4.85	5.0	5.1	V
ISET Voltage		4.7	4.8	5.1	V
Error Amplifier Section					
FB Voltage		2.4	2.5	2.6	V
FB Input Current		-1	0	1	μA
FB Sink Current	VOUTSENSE = 4V, FB = 4V	0.3	1.5		mA
FB Release Delay	VOUTSENSE Step from 4V to 1V	17	30	43	ms
COMP Source Current	FB = 2V, COMP = 4V		-3.0	-0.2	mA
COMP Sink Current	FB = 3V, COMP = 1V	0.2	1.0		mA

ELECTRICAL CHARACTERISTICS (cont.) Unless otherwise stated, VCC = 6.6V, ISET = 100kΩ to GND, ADJ = 100kΩ to GND, OSC = 200pF to GND, BAT = 4V, LOADISENSE connected to LPOWER, VOUTSENSE = 0.666V, BOOST = 10.5V, COMP connected to FB through a 100kΩ resistor, -40°C < TA < +105°C for the UCC2305, 0°C < TA < +70°C for the UCC3305, and TA = TJ.

PARAMETER	TEST CONDITIONS	MIN.	TYP.	MAX.	UNITS
Load Power Amplifier Section					
LOADISENSE Input Current		-2.5	-0.1	2.5	μA
LPOWER Source Current	LPOWER = 0V		-8.0	-0.4	mA
LPOWER Sink Current	LPOWER = 1V	0.4	1.3		mA
LPOWER Voltage	VOUTSENSE = 0.0V	0.35	0.40	0.45	V
	VOUTSENSE = 0.45V	0.35	0.40	0.45	V
	VOUTSENSE = 0.65V	0.41	0.46	0.51	V
	VOUTSENSE = 0.88V	0.46	0.51	0.56	V
	VOUTSENSE = 2.0V	0.46	0.51	0.56	V
	VOUTSENSE = 0.7V, SLOPEC = 0V	0.29	0.34	0.39	V
Input Current Sense Section					
ISENSEIN Threshold	COMP = 5V, WARMUPC = 0V	0.16	0.21	0.28	V
	COMP = 5V, WARMUPC = 10V	0.13	0.19	0.27	V
	COMP = 1V, WARMUPC = 0V	0.07	0.10	0.2	V
ISENSEIN Bias Current	OSC = 0V	-15	-5	-2	μA
	OSC = 2V	-65	-40	-15	μA
VOUTSENSE Section					
VOUTSENSE Threshold to PWMOUT		4.2	5.0	5.2	V
VOUTSENSE Threshold to FB		1.7	1.9	2.1	V
VOUTSENSE Threshold to NOTON		0.035	0.083	0.140	V
VOUTSENSE Input Current		-1		1	μA
OUTPUTS SECTION					
PWMOUT High Voltage	IPWMOUT = -100mA	9.15	10.0		V
PWMOUT Low Voltage	IPWMOUT = 100mA		0.3	0.5	V
PUMPOUT High Voltage	IPUMPOUT = -10mA	5.3	5.8		V
PUMPOUT Low Voltage	IPUMPOUT = 10mA		1.0	1.8	V
PUMPOUT Frequency	BOOST = 9.5V	35	50	60	kHz
NOTON High Voltage	INOTON = -1mA	5.0	6.3		V
NOTON Low Voltage	INOTON = 1mA		0.1	0.3	V
QOUT, \overline{QOUT} High Voltage	I _{QOUT} = -1mA or I _{QOUT} = -1mA	5.0	6.3		V
QOUT, \overline{QOUT} Low Voltage	I _{QOUT} = 1mA or I _{QOUT} = 1mA		0.1	0.45	V
QOUT, \overline{QOUT} Frequency		175	250	275	Hz
FLT High Voltage	IFLT = -1mA	6.0	6.3		V
FLT Low Voltage	IFLT = 1mA		0.1	0.3	V
Timing Capacitor Section					
FLTC Discharge Current	FLTC = 2.5V	35	60	90	nA
FLTC Charge Current	FLTC = 2.5V	-380	-290	-220	nA
FLTC Threshold to FAULT		4.65	4.9	5.1	V
SLOPEC Charge Current	SLOPEC = 0.5V	-165	-90	-60	nA
	SLOPEC = 2.2	-105	-60	-40	nA
	SLOPEC = 4.2	-35	-20	-10	nA
SLOPEC Voltage	ISLOPEC = -125nA	1.3	1.5	1.7	V
	ISLOPEC = -50nA	2.8	3.0	3.2	V

ELECTRICAL CHARACTERISTICS (cont.) Unless otherwise stated, VCC = 6.6V, ISET = 100kΩ to GND, ADJ = 100kΩ to GND, OSC = 200pF to GND, BAT = 4V, LOADISENSE connected to LPOWER, VOUTSENSE = 0.666V, BOOST = 10.5V, COMP connected to FB through a 100kΩ resistor, -40°C < TA < +105°C for the UCC2305, 0°C < TA < +70°C for the UCC3305, and TA = TJ.

PARAMETER	TEST CONDITIONS	MIN.	TYP.	MAX.	UNITS
Timing Capacitor Section (cont.)					
SLOPEC Discharge Current	SLOPEC = 2.2V, VCC = 0V, BOOST = 0V, BYPASS = 8V	40	90	175	nA
WARMUPC Charge Current	WARMUPC = 0V	-515	-375	-275	nA
	WARMUPC = 2V	-450	-375	-300	nA
	WARMUPC = 6V	-170	-120	-75	nA
WARMUPC Voltage, Charging	I _{WARMUPC} = -250nA	3.5	3.8	4.1	V
WARMUPC Discharge Current	WARMUPC = 5V, VCC = 0V, BOOST = 0V, BYPASS = 8V	23	50	108	nA
	WARMUPC = 1V, VCC = 0V, BOOST = 0V, BYPASS = 8V	5	10	20	nA
WARMUPC Voltage, Discharging	I _{WARMUPC} = 25nA, VCC = 0V, BOOST = 0V, BYPASS = 8V	1.5	1.9	2.3	V
ADJ Bias Current	V _{ADJ} = 0V	-38	-20	-12	μA
WARMUPV Voltage	WARMUPC = 1V	0.05	0.125	0.25	V
	WARMUPC = 2V	0.09	0.108	1.27	V
	WARMUPC = 3V	2.3	2.48	2.66	V
	WARMUPC = 5V	4.5	4.8	5.1	V
	WARMUPC = 10V	4.5	4.8	5.1	V
BYPASS Voltage	VCC = 0V	8.8	9.6		V
BYPASS Current	VCC = 0V, BOOST = 0V, BYPASS = 8V		2.5	7	μA

PIN DESCRIPTIONS

5VREF: Circuitry in the UCC3305 uses the internal 5V reference to set currents and thresholds. This reference can also be used for other functions if required.

ADJ: The ratio of cold lamp peak current to warmed-up lamp peak current is controlled by the voltage on ADJ. To select this voltage, connect a resistor from ADJ to GND.

BAT: This input is used to detect excessively high input voltage and shut down the IC if the input exceeds a pre-determined level. Connect BAT to a voltage divider across the input supply. The UCC3305 shuts down when this input voltage exceeds 5V. To protect the IC in the event of very high or negative inputs, keep divider impedance higher than 10k.

BOOST: Although the UCC3305 is powered from the VCC input, most functions of the device operate from a supply voltage of approximately 10V connected to BOOST. This 10V supply can be generated by a voltage doubler using PUMPOUT as an AC signal and external diodes as switches.

BYPASS: The UCC3305 compensates for lamp temperature changes by changing the voltage on the SLOPEC and WARMUPC capacitors. These voltages rise as the lamp warms up. An internal calculation determines what power should be applied to the lamp.

When the HID lamp is turned off, power to the lamp and the controller is removed, leaving these two critical capacitors charged to specific voltages. Also, with power off, the lamp will cool down at a controlled rate. It is essential that the two capacitors discharge at a similarly controlled rate so that if the lamp is restarted before the lamp is fully cooled, the controller will have an estimate of new lamp temperature, and can again command the correct power for the lamp.

Power to control the discharge of these capacitors comes from energy stored in a large capacitor connected to BYPASS. The value of the capacitor required can be estimated assuming a maximum BYPASS current of 5μA, a discharge time of 60s, and a maximum allowable droop of 5V by:

$$C = I \cdot \frac{\Delta t}{\Delta V} = 5\mu\text{A} \cdot \frac{60\text{s}}{5\text{V}} = 60\mu\text{F}$$

COMP: Differences between commanded lamp power and desired lamp power are amplified by an error amplifier. This amplifier senses the difference between the voltage at FB and 2.5V, and drives COMP with an amplified error voltage. A capacitor is normally connected from COMP to FB to compensate the overall feedback loop so that the system will be stable.

PIN DESCRIPTIONS (cont.)

DIVPAUSE: The QOUT and $\overline{\text{QOUT}}$ outputs can be used to switch lamp polarity in an AC ballast. It is important to stop polarity switching when the lamp is being lit, so that the arc across the electrodes can form in the correct place. Pulling high on DIVPAUSE stops the internal divider which generates the QOUT and $\overline{\text{QOUT}}$ signals, and thereby freezes the QOUT and $\overline{\text{QOUT}}$ signals.

To stop the divider when the lamp is being lit and start after the lamp has lit, connect a resistor from NOTON to DIVPAUSE and a capacitor from DIVPAUSE to GND.

FLTC: The voltage on VOUTSENSE is proportional to lamp voltage. If that voltage is too high or too low, the lamp is either open, shorted, or not yet running. During normal operation, there is a capacitor connected to FLTC, and this capacitor is discharged to 0V by a current source inside the UCC3305.

The UCC3305 monitors the voltage on VOUTSENSE and compares it to an internal 83mV lower threshold and a 2V upper threshold. If the voltage is outside this window, then the IC will pull up on FLTC with a current of approximately 250nA. If the fault remains long enough to charge the external FLTC capacitor over 5V, the controller declares a catastrophic fault and shuts the IC down. The IC will stay shut down until power is removed from BOOST.

If the fault clears before the FLTC capacitor reaches 5V, the capacitor discharges down to 0V. This discharge current is approximately 50nA, representing a five times longer discharge rate than charge rate.

FLT: If the voltage on the FLTC pin exceeds 5V, indicating a severe fault, then a latch in the UCC3305 sets and PWM drive is halted. In addition, the FLT output goes high to VCC, indicating a serious system fault.

FB: Differences between commanded lamp power and desired lamp power are amplified by an error amplifier. This amplifier senses the difference between the voltage at FB and 2.5V, and drives COMP with an amplified error voltage.

GND: Ground for all functions is through this pin.

ISENSEIN: The power regulating algorithm in the UCC3305 HID Controller computes a function of lamp current and lamp voltage and commands the appropriate battery current to keep lamp power constant. This appropriate battery current is sensed by a connection from ISENSEIN to a current sense resistor. This current sensed pulse width modulation scheme is often referred to as current mode control.

In addition to this current regulation, the UCC3305 contains peak input current limiting. This limiting is set to 0.2V across the ISENSEIN resistor during normal operation and 0.4V during starting. The transition from starting

to normal operation is accomplished by the rise of the WARMUPC capacitor.

Current mode control has an advantage over voltage mode control in that a current mode loop is easier to compensate. Current mode control has a disadvantage compared to voltage mode control in that the loop can enter into chaotic oscillations at high duty cycles. These chaotic oscillations can be prevented using slope compensation. The UCC3305 contains internal slope compensation in the form of a current proportional to OSC voltage on ISENSEIN. This current combined with an external resistor from ISENSEIN to the current sense resistor creates a voltage drop proportional to OSC voltage, which gives slope compensation.

ISET: Many functions inside the UCC3305 require precise currents to give well controlled performance. These controlled currents are programmed by a resistor from ISET to GND. A resistor of 100k programs the IC to normal operating current. Lower resistor values increase the internal currents. Some of the functions which are influenced by this resistor are WARMUPC charging and discharging, SLOPEC charging and discharging, FLTC charging and discharging, and error amplifier bandwidth

LOADISENSE: Just as ISENSEIN is normally connected to a current sense resistor which monitors battery current, LOADISENSE is normally connected to a resistor which monitors lamp current. Lamp current is then regulated by the controller such that the correct lamp power is supplied at every lamp temperature, in conjunction with the lamp voltage sensed by VOUTSENSE.

LPOWER: LOADISENSE directly drives one input of an op amp in the UCC3305. This amplifier amplifies the difference between the desired load current and the actual load current, and generates an output signal on LPOWER which feeds the error amplifier.

NOTON: While the lamp is in a fault condition, such as excessively high or low lamp voltage, NOTON is pulled high to VCC, indicating that the arc is not yet correct. When the voltage on VOUTSENSE is within the 83mV to 2V window, NOTON is pulled low.

OSC: The fixed frequency PWM in the UCC3305 operates at the frequency programmed by the OSC pin. Typically, a 200pF capacitor from OSC to GND programs the PWM frequency at 100kHz. In addition, this programs the charge pump at 50kHz and the $\overline{\text{QOUT}}$ and QOUT signals at 192Hz. The actual oscillator frequency is a function of both the capacitor from OSC to GND and the resistor from ISET to GND.

PUMPOUT: Although the UCC3305 is powered from the VCC input, most functions of the device operate from a supply voltage of approximately 10V connected to BOOST. In normal operation, this 10V supply is gener-

PIN DESCRIPTIONS (cont.)

ated by a voltage doubler using the PUMPOUT pin as an AC signal and external diodes as switches. PUMPOUT is a square wave which swings from VCC to GND at half of the OSC frequency.

PWMOUT: The output of the pulse width modulator is a command signal to a power MOSFET switch. This signal appears on PWMOUT. In normal systems, PWMOUT can be directly connected to the gate of an N-channel power MOSFET such as the IRF540. If the lead between the UCC3305 and the MOSFET is longer than a few cm, a 10 ohm resistor from PWMOUT to gate may be required to dampen overshoot and undershoot.

QOUT: The UCC3305 is immediately configured for DC HID lamps. To operate with AC HID lamps, it is necessary to add a power H-bridge which will toggle lamp voltage. A practical switching frequency for this toggle function is the OSC frequency divided by 512, or 192Hz for a 100kHz oscillator.

The QOUT pin is a logic output which toggles at the OSC frequency divided by 512, 180 degrees out of phase with the QOUT pin.

QOUT: The QOUT pin is a logic output which toggles at the OSC frequency divided by 512, 180 degrees out of phase with the QOUT pin.

SLOPEC: To track lamp warm-up and cool down, two capacitors connected to the UCC3305 charge and discharge. One is connected to SLOPEC. The other is connected to WARMUPC. The capacitor connected to SLOPEC charges up to 5V with a rate controlled by the resistor from ISET to GND. With a nominal 100k ISET resistor the charging current into SLOPEC is equivalent to the current from a 50M Ω resistor to 5V.

When power is removed from VCC, SLOPEC discharges at a constant current, nominally 100nA.

VCC: VCC is the main supply input to the UCC3305. Many functions in the UCC3305 are powered by VCC,

APPLICATIONS INFORMATION

Typical Application

This circuit shows the UCC3305 HID Lamp Controller IC in a flyback converter. The output of the converter is regulated at constant power, so that lamp intensity is relatively constant regardless of small lamp manufacturing variations.

Full Bridge Output Stage

The output of the flyback converter is directed to the AC lamp through a full bridge inverter. The full bridge is switched at a low frequency (typically 195Hz), so that the average lamp voltage is zero. The low frequency switch-

while others are powered by BOOST. VCC should be clamped to 6.8V by an external zener diode and kept as close to 6.8V as practical with a low value resistor to the input supply.

VOUT-SENSE: The VOULTSENSE input is used to sense lamp voltage, commonly through a 120:1 voltage divider. For a normal, running HID lamp, the voltage across the lamp is between 60V and 110V. It takes higher than 300V to break down the lamp, and it is desirable to limit the voltage on the starter input to 600V maximum. A lamp voltage less than 10V is indicative of a shorted lamp.

The UCC3305 regulates lamp power by commanding the correct lamp current for a given lamp voltage. In addition, a comparator in the UCC3305 terminates a PWM cycle if VOULTSENSE reaches 5V, corresponding to 600V on the lamp. This regulates lamp voltage at 600V when the lamp is not lit. Comparators in the UCC3305 also compare VOULTSENSE to 83mV corresponding to 10V lamp voltage and 2V, corresponding to a 240V lamp voltage. When the VOULTSENSE voltage is outside this window, the lamp is either not lit, shorted, or open.

WARMUPC: In addition to the capacitor from SLOPEC to GND, lamp temperature is estimated by the voltage on a capacitor from WARMUPC to GND. This capacitor is charged by a 200nA current source to 4.2V and by a 100nA current source from 4.2V to 10V when the lamp is on, and discharged by 39nA current sink to 2.5V and 11nA current sink to GND when the lamp is off.

WARMUPV: The voltage on WARMUPC is used to modulate the signal fed to the error amplifier through FB. However, the impedance on WARMUPC is too high to be directly used. The UCC3305 contains a buffer amplifier which buffers the voltage on WARMUPC and processes it to WARMUPV, making a signal appropriate for driving FB.

ing is derived from the PWM oscillator. It is desirable to switch lamp polarity when running, but switching lamp polarity can interfere with clean starting. The UCC3305 has a logic output called NOTON which is high when the lamp is not running (Not On) and low when the lamp is running. This output is connected to the DIVPAUSE input so that the low frequency switching stops until the lamp is fully lit.

The UCC3305 HID Controller IC has two low frequency outputs, QOUT and QOUT. These outputs are capable of driving low-side MOSFETs directly at 195Hz, but high-side MOSFETs require a level-shifted drive. This can be

APPLICATIONS INFORMATION (cont.)

as simple as a high voltage transistor and a resistor pull-up, combined with the correct choice of phases.

Regulated Lamp Input Power Gives Constant Intensity

The LPOWER output of the UCC3305 is a voltage roughly proportional to lamp input power. The UCC3305 regulates constant lamp power over a wide range of lamp voltages. The range of lamp voltages which produce constant lamp power is set by the limiting amplifier on VOUT-SENSE.

For inputs to VOUTSENSE below 0.5V, such as would occur with a shorted lamp, the loop regulates constant load current. For inputs to VOUTSENSE greater than 0.82V, as might occur with a lamp that is open or not yet lit, the loop also regulates constant load current, but at a lower current than for a shorted lamp. In between those two voltages, the amplifier driving the LPOWER pin will sum the load current and load voltage and produce a signal roughly proportional to load power. The summing amplifier approximates power well enough to hold power within $\pm 10\%$ over a factor of two in lamp voltage.

The UCC3305 HID Controller contains a current mode PWM similar to the industry standard UC3842 and UCC3802 circuits. This controller uses a high gain op amp to regulate the output of the LPOWER circuit. This op amp drives a high speed PWM comparator, which compares converter input current to the output of the op amp and uses this signal to set duty cycle.

Slope Compensation

In addition to a complete current mode PWM, the UCC3305 HID Controller contains internal slope compensation, a valuable function which improves current loop stability for high duty cycles. Slope compensation is accomplished with an on-chip current ramp and an off-chip resistor RSL. Larger values of RSL give more slope compensation and a more stable feedback loop.

Powering The UCC3305

Conventional power MOSFETs require at least 8V of gate drive to ensure high efficiency and low on resistance. Despite this requirement, the UCC3305 HID Controller can be used to build a ballast that will drive power MOSFETs well with input supplies as low as 5V! The UCC3305 does this using a charge pump.

In this typical application, power for the UCC3305 HID Controller IC is derived from a 6.8V zener supply. This zener regulated supply gives the application overvoltage protection, reverse battery protection, low parts count, and low cost. The output of the 6.8V zener supply drives the VCC pin of the UCC3305. VCC is the input to the UCC3305 charge pump. The charge pump generates a

regulated 10V supply on the BOOST output. This 10V supply drives all other functions on the UCC3305.

Protection From Over Voltage

The most significant stresses in an automotive environment are the overvoltage conditions which can occur during load dump and double-battery jump start. At these times, the voltage into the ballast can go so high that even the most overdesigned power stage will be damaged. The UCC3305 is inherently immune to damage from this when operated with a zener regulated supply. In addition, the UCC3305 will protect the ballast components by shutting down the PWM in the presence of excessive voltage on the BAT input.

This typical application shows a voltage divider consisting of a 270k resistor and a 100k resistor driving the BAT input. The threshold of the BAT input is approximately 5V, so this divider sets the shutdown voltage at approximately 18.5V.

Programming the UCC3305

All circuitry on the UCC3305 HID Lamp Controller is operated from a bias current set by the resistor from ISET to ground. For best operation, this resistor (RSET) should be between 75k and 150k.

Oscillator Frequency

The UCC3305 HID Lamp Controller PWM oscillator is set by the resistor from ISET to ground and by the capacitor from OSC to ground. Oscillator frequency can be estimated by the equation:

$$F_{OSC} = \frac{2}{R_{SET} \cdot C_{OSC}}$$

For operation at 100kHz, RSET should be 100k and COSC should be 200pF.

The PWM oscillator also determines the low frequency lamp switching rate for AC lamps. The exact lamp switching rate is the PWM frequency divided by 512.

Lamp Temperature Compensation

Automobile headlights must come up to full intensity very quickly, but HID lamps require many minutes to stabilize. The UCC3305 HID Controller contains sophisticated internal circuitry to anticipate lamp temperature and also to compensate for lamp temperature.

The circuits anticipate lamp temperature by monitoring charge on capacitors which charge when the lamp is on and discharge when the lamp is off. The UCC3305 HID Controller compensates for lamp temperature by driving the lamp with a higher lamp power when the lamp is cold and reducing the power to a normal operating level when the lamp is warmed up. The capacitors which set these

APPLICATIONS INFORMATION (cont.)

time constants are external film capacitors CS and CW, and are connected to SLOPEC and WARMUPC. CS and CW are critical capacitors and must be selected to match the time-temperature relationship of the lamp.

In addition to changing the power regulation point, the WARMUPC capacitor voltage also changes the short circuit lamp current. The ratio of cold short circuit current to warmed-up short circuit current is set by the resistor from ADJ to ground.

When power is removed from the ballast, CS and CW must discharge at a controlled rate. The discharge currents are programmed by current sources on the UCC3305 HID Controller. These current sources are powered by the power supply connected to BYPASS. In a typical application, a non-critical electrolytic capacitor from BYPASS to ground stores energy when the ballast is on and uses this energy to control the discharge rate when the ballast is off.

FLYBACK HID BALLAST

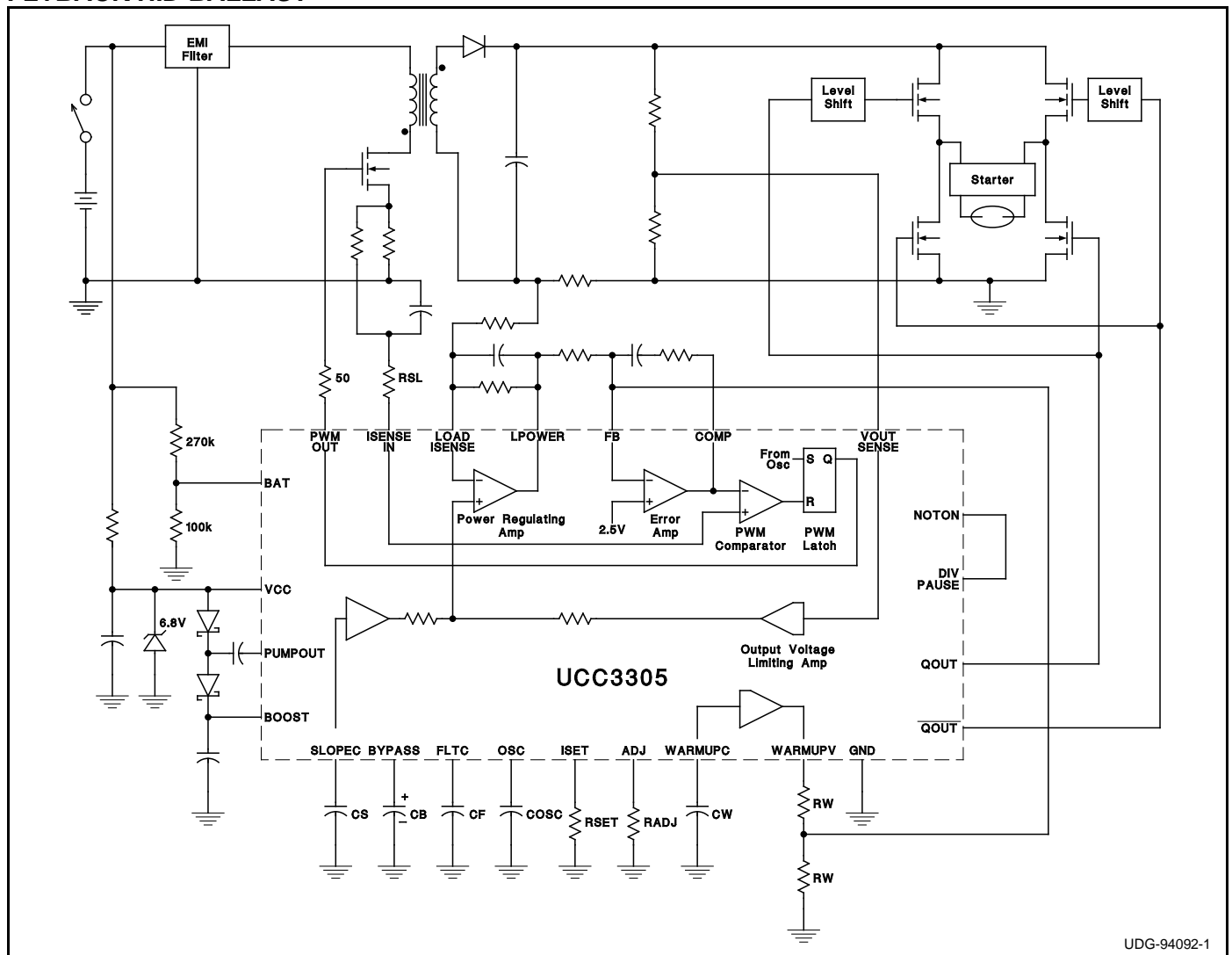

UDG-94092-1

IMPORTANT NOTICE

Texas Instruments and its subsidiaries (TI) reserve the right to make changes to their products or to discontinue any product or service without notice, and advise customers to obtain the latest version of relevant information to verify, before placing orders, that information being relied on is current and complete. All products are sold subject to the terms and conditions of sale supplied at the time of order acknowledgement, including those pertaining to warranty, patent infringement, and limitation of liability.

TI warrants performance of its semiconductor products to the specifications applicable at the time of sale in accordance with TI's standard warranty. Testing and other quality control techniques are utilized to the extent TI deems necessary to support this warranty. Specific testing of all parameters of each device is not necessarily performed, except those mandated by government requirements.

CERTAIN APPLICATIONS USING SEMICONDUCTOR PRODUCTS MAY INVOLVE POTENTIAL RISKS OF DEATH, PERSONAL INJURY, OR SEVERE PROPERTY OR ENVIRONMENTAL DAMAGE ("CRITICAL APPLICATIONS"). TI SEMICONDUCTOR PRODUCTS ARE NOT DESIGNED, AUTHORIZED, OR WARRANTED TO BE SUITABLE FOR USE IN LIFE-SUPPORT DEVICES OR SYSTEMS OR OTHER CRITICAL APPLICATIONS. INCLUSION OF TI PRODUCTS IN SUCH APPLICATIONS IS UNDERSTOOD TO BE FULLY AT THE CUSTOMER'S RISK.

In order to minimize risks associated with the customer's applications, adequate design and operating safeguards must be provided by the customer to minimize inherent or procedural hazards.

TI assumes no liability for applications assistance or customer product design. TI does not warrant or represent that any license, either express or implied, is granted under any patent right, copyright, mask work right, or other intellectual property right of TI covering or relating to any combination, machine, or process in which such semiconductor products or services might be or are used. TI's publication of information regarding any third party's products or services does not constitute TI's approval, warranty or endorsement thereof.