

# Quad PWM Relay Driver

## FEATURES

- Maintains Constant Average Relay Voltage With Varying Supply Voltages
- VBUS Voltages up to 42.5V
- Up to 50mA per Relay
- Integrated Schottky Flyback Diodes
- Individual Relay Control Inputs
- Short Circuit Protection
- User Selectable Operating Center Frequency and Relay Voltage
- Global Reset

## DESCRIPTION

The UC3702 Quad Relay Driver is intended to drive up to four relays from logic inputs using an unregulated relay voltage supply. The relays are driven from the Bus supply in a power efficient PWM converter fashion. The relay coil is used as the inductive element. (See the application's section concerning the relay selection.) VBUS must be higher than the rated relay voltage. Short circuit protection is provided on chip with periodic retry.

The UC3702 requires a +5V logic supply as a reference. Two external resistors program the effective relay voltage and a capacitor sets the nominal operating frequency. Internal Schottky diodes eliminate the need for any external power components.

In typical applications, the UC3702 grants the user the flexibility to choose the most cost effective relay without the added burden of generating a separate relay supply voltage. The UC3702 will even function with a poorly regulated supply VBUS, containing significant 100Hz or 120Hz ripple.

## BLOCK DIAGRAM

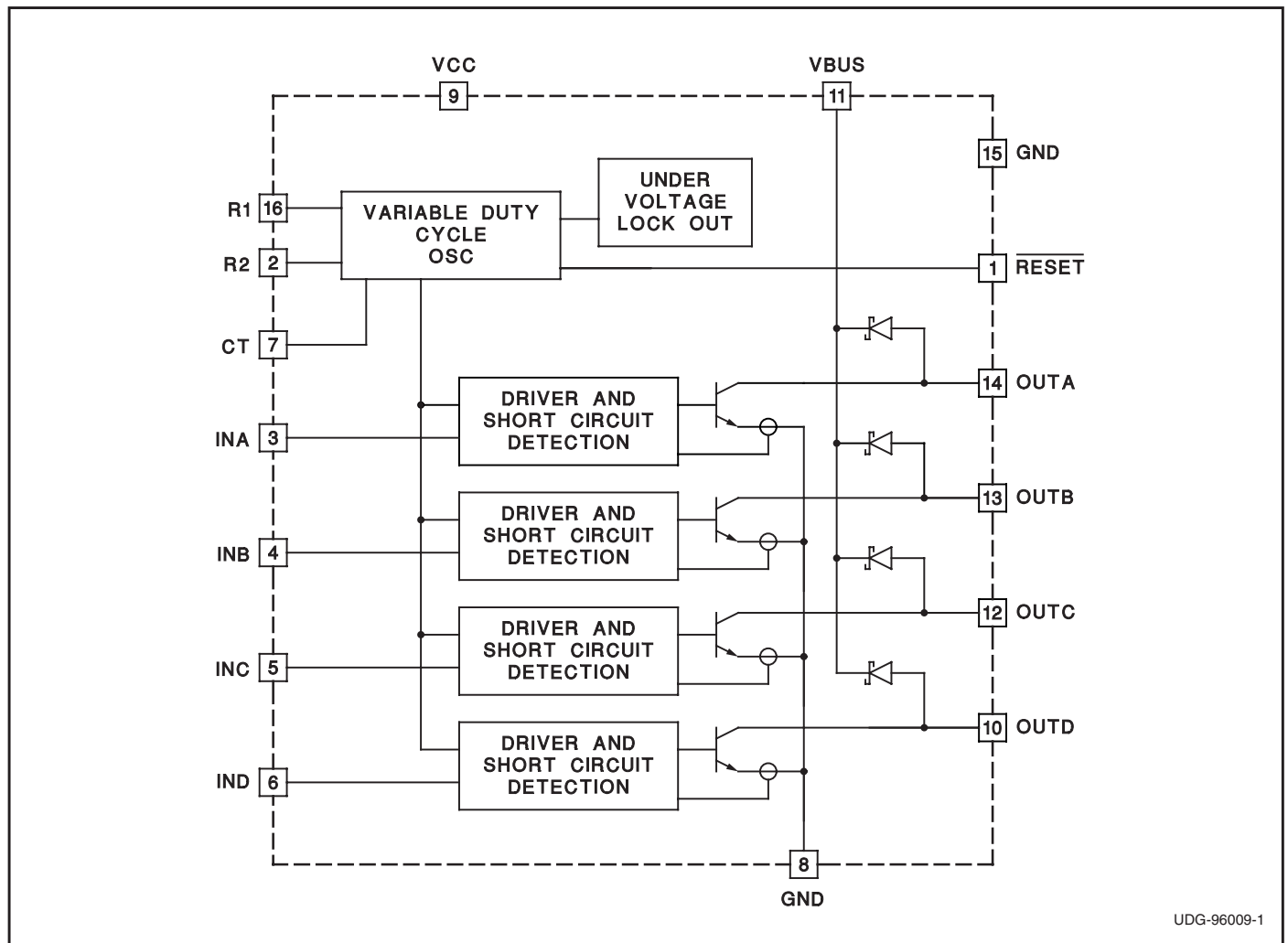

UDG-96009-1

### ABSOLUTE MAXIMUM RATINGS

VBUS	+50V
VCC	+9V
Input Voltage	-0.3V to VCC + 0.3V
Average Current per Relay	50mA
Total Output Capacitance	25pF
Storage Temperature	-65°C to +150°C
Junction Temperature	-55°C to +150°C
Lead Temperature (Soldering, 10 sec.)	+300°C

Currents are positive into, negative out of the specified terminal. Consult Packaging Section of Databook for thermal limitations and considerations of packages.

### CONNECTION DIAGRAM

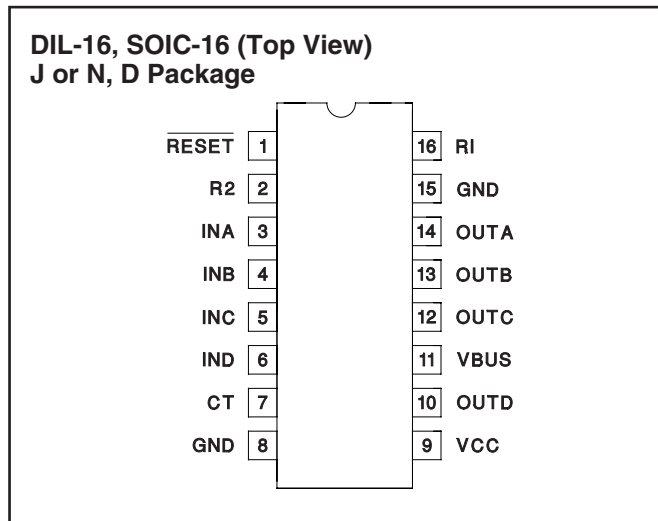

**ELECTRICAL CHARACTERISTICS:** Unless otherwise stated these specifications apply for  $T_A = -55^\circ\text{C}$  to  $+125^\circ\text{C}$  for UC1702;  $-25^\circ\text{C}$  to  $+85^\circ\text{C}$  for UC2702;  $0^\circ\text{C}$  to  $+70^\circ\text{C}$  for UC3702;  $\text{VBUS} = 34\text{V}$ ,  $\text{VCC} = 5\text{V}$ ,  $\text{RESET} = \text{VCC}$ ,  $\text{R2} = 43.2\text{k}\Omega$ ;  $\text{R1} = 203\text{k}\Omega$ ;  $\text{CT} = 220\text{pF}$ ,  $T_A = T_J$ .

PARAMETER	TEST CONDITIONS	MIN	TYP	MAX	UNITS
<b>Supply Voltage Section</b>					
VCC		4.5	5	8	V
VCC Supply Current	RESET, INA, INB, INC, IND = VCC		4	6	mA
VBUS				42.5	V
<b>Oscillator Section</b>					
NOMINAL Operating Frequency	R1 = 203k $\Omega$ , R2 = 43.2k $\Omega$ , CT = 220pF	150	175	200	kHz
R1		100	202	500	k $\Omega$
R2		20	42.5	80	k $\Omega$
CT		100			pF
<b>Output Driver VBUS = 20V</b>					
Rated Relay Current				50	mA
Short Circuit Current		100	175		mA
Diode Leakage Current	Control Input Low, $V_{\text{OUTX}} = \text{VBUS}$		0.05	5	$\mu\text{A}$
Diode Forward Voltage			500		mV
Averaged Output Voltage Error	UC2702, UC3702 (Note 1)	-10		10	%
	UC1702	-20		20	%
<b>Control Inputs (INA, INB, INC, IND)</b>					
Logic Low				0.5	V
Logic High		3		VCC	V
TON / TOFF Delay				250	ns
Input Current		-1	0	1	$\mu\text{A}$
Input Current	$V_{\text{IN}} = 5\text{V}$		70	120	$\mu\text{A}$
<b>RESET</b>					
TON / TOFF Delay				2	$\mu\text{s}$
Input Current	$V_{\text{IN}} = 0.3\text{V}$	-8	-5		$\mu\text{A}$
Input Current	$V_{\text{IN}} = 5\text{V}$	-10	0	10	$\mu\text{A}$

Note 1: Programmed Average Voltage =  $\frac{1.06 \cdot \text{R1} \cdot \text{VCC}}{2 \cdot \text{R2}} - 400\text{mV}$

## PIN DESCRIPTIONS

**CT:** A capacitor from the CT pin to ground sets the oscillator center frequency. Note that the oscillator period must be least an order of magnitude less than the relaxation time constant (L/R) of the relay coil. However, a needlessly high operating frequency only increases power dissipation. For best accuracy, CT should be 220pF or greater.

**GND:** Both ground pins must be connected to a low noise system ground.

**INA, INB, INC, IND:** Separate digital control inputs for each of the four relay drivers. An active high input (a logic high) turns on the respective relay. Active low disables the common-emitter drive transistor.

**OUTA, OUTB, OUTC, OUTD:** Each of these output pins can be connected to the low side of one relay coil. The rated relay coil voltage of all relays to be driven by a single UC3702 must be the same. (It is permissible to use coils with different rated series resistances with a single UC3702, so long as the rated coil voltages are the same and care is taken with respect to the relaxation times of the different relay coils). Output transients are slew rate limited to decrease electro-magnetic radiation.

**R1:** User selected external resistor must be placed from the R1 pin to the VBUS voltage supply. Sensing the

VBUS amplitude, the oscillator varies its ON duty cycle such that the average voltage across the driver coil is constant.

**R2:** User selected external resistor must be placed from R2 pin to GND. This resistor, in conjunction with the external timing capacitor, CT, sets the OFF cycle time of the oscillator. For best accuracy, use 42.3kΩ for R2.

**RESET:** Digital reset pin is active low. When RESET is low, the oscillator stops running and all drivers are open collector.

**VCC:** Nominally 5V. In addition to supplying the voltage for the driver logic and oscillator circuit, the VCC supply is used as reference for the generating the average relay voltage. It is recommended that the VCC be regulated to ±5% of its nominal value or better to insure good regulation. Good decoupling with a minimum of 1μF is necessary.

**VBUS:** This pin should be tied to a low impedance voltage source at some voltage higher than the rated voltage of the relay coil to be driven. VBUS may even be a poorly filtered rectified sin wave, as the UC3702 will regulate the correct duty cycle. Good decoupling with a minimum of 1μF is necessary.

## APPLICATIONS INFORMATION

The UC3702 must be programmed for a specific relay voltage. The table given below has some suggested val-

Rated Relay Voltage	R1	R2	CT
9V	153kΩ	43.2kΩ	220pF
12V	203kΩ	43.2kΩ	220pF
24V	398kΩ	43.2kΩ	220pF

ues of R1, R2, and CT. The VCC supply voltage is assumed to be 5V.

More generally, the following equation can be used to determine the equivalent average relay voltage:

$$V_{RELAY} = \frac{1.06 \cdot VCC \cdot R1}{2 \cdot R2} - 400mV$$

## Industrial Relays

The UC3702 takes advantage of the inductance of the relay coil to regulate a constant coil current in a manner very similar to a switch-mode power supply. To use the UC3702 correctly, the coil characteristics must be known. The rated relay voltage is what the relay manufacturers specify as voltage to drive the relay coil with if the coil were driven from a dc source. Most manufacturers also specify the series resistance of the coil. This is the resistance of the copper wire and determines the steady state coil ON current. For example, a 12V relay with a 320Ω series coil resistance with a draw of 37.5mA of constant current. The relay inductance is not typically specified in the manufacturer's short-form datasheet, so the engineer will need an LCR bridge to measure it or request the information from the relay manufacturer.



## **IMPORTANT NOTICE**

Texas Instruments and its subsidiaries (TI) reserve the right to make changes to their products or to discontinue any product or service without notice, and advise customers to obtain the latest version of relevant information to verify, before placing orders, that information being relied on is current and complete. All products are sold subject to the terms and conditions of sale supplied at the time of order acknowledgment, including those pertaining to warranty, patent infringement, and limitation of liability.

TI warrants performance of its semiconductor products to the specifications applicable at the time of sale in accordance with TI's standard warranty. Testing and other quality control techniques are utilized to the extent TI deems necessary to support this warranty. Specific testing of all parameters of each device is not necessarily performed, except those mandated by government requirements.

Customers are responsible for their applications using TI components.

In order to minimize risks associated with the customer's applications, adequate design and operating safeguards must be provided by the customer to minimize inherent or procedural hazards.

TI assumes no liability for applications assistance or customer product design. TI does not warrant or represent that any license, either express or implied, is granted under any patent right, copyright, mask work right, or other intellectual property right of TI covering or relating to any combination, machine, or process in which such semiconductor products or services might be or are used. TI's publication of information regarding any third party's products or services does not constitute TI's approval, warranty or endorsement thereof.