

12-Bit Sampling A/D Converters

- 3 μ s, 5 μ s or 10 μ s Sample/Conversion Time
- Unipolar 0V to +10V and 0V to +5V Input
- No Missing Codes Over Temperature
- AC Performance Over Temperature
 - 72dB Signal-to-Noise Ratio at Nyquist
 - 85dB Spurious-free Dynamic Range at 49kHz
 - 81dB Total Harmonic Distortion at 49kHz
- Internal Sample/Hold, Reference, Clock, and 3-State Outputs
- Power Dissipation: 90mW
- 28-Pin Narrow PDIP and SOIC Packages



DESCRIPTION...

The **SP86XX Series** are complete, unipolar, 12-bit sampling A/D converters using state-of-the-art CMOS structures. They contain a complete 12-bit successive approximation A/D converter with internal sample/hold, reference, clock, digital interface for microprocessor control, and three-state output drivers. Power dissipation is only 90mW. AC and DC performance are completely specified. Sampling/conversion rates of 3 μ s, 5 μ s and 10 μ s are offered.

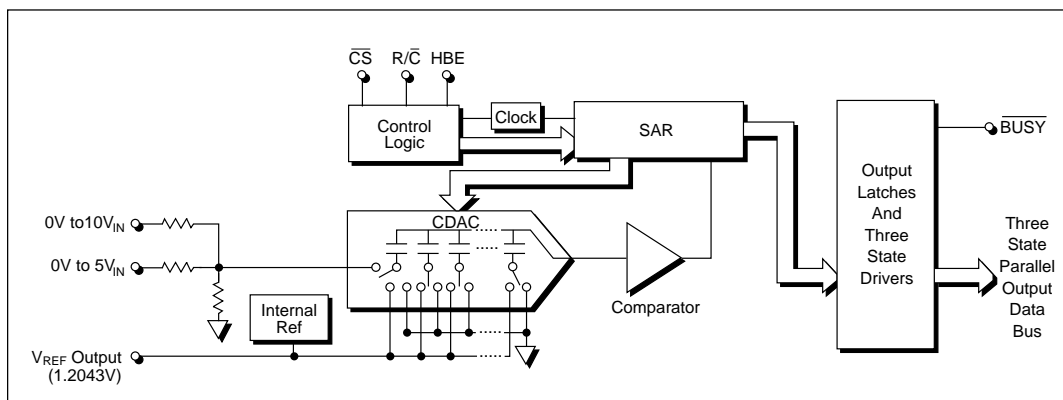

ABSOLUTE MAXIMUM RATINGS

These are stress ratings only and functional operation of the device at these or any other above those indicated in the operation sections of the specifications below is not implied. Exposure to absolute maximum rating conditions for extended periods of time may affect reliability.

V_S to Digital Common	+7V
Pin 26 (V_{SD}) to Pin 27 (V_{SD})	$\pm 0.3V$
Analog Common to Digital Common	$\pm 0.3V$
Control Inputs to Digital Common	-0.3 to $V_S + 0.3 V$
Analog Input Voltage	$-3.0/+16.5V$
Maximum Junction Temperature	160°C
Internal Power Dissipation	750mW

Lead Temperature (soldering, 10s)	+300°C
Thermal Resistance, θ_{JA} :	
Plastic DIP	50°C/W
SOIC	100°C/W



CAUTION:
ESD (ElectroStatic Discharge) sensitive device. Permanent damage may occur on unconnected devices subject to high energy electrostatic fields. Unused devices must be stored in conductive foam or shunts. Personnel should be properly grounded prior to handling this device. The protective foam should be discharged to the destination socket before devices are removed.

SPECIFICATIONS

($T_A = 25^\circ C$; Sampling Frequency, $F_{S1} = 333kHz$ for SP8603, 200kHz for SP8605, 100kHz for SP8610, $V_S = +5V$, unless otherwise specified.)

PARAMETER	MIN.	TYP.	MAX.	UNITS	CONDITIONS
ANALOG INPUT					
Voltage Ranges	0V to +5V, 0V to +10V			V	Unipolar
Impedance					
0 to +10V Range	5.4	7.7	10.0	k Ω	$T_{MIN} \leq T_A \leq T_{MAX}$
0 to +5V Range	3.9	5.6	7.3	k Ω	$T_{MIN} \leq T_A \leq T_{MAX}$
DC PERFORMANCE					
Full Scale Error					Externally adjustable to zero;
-K		± 0.1	± 0.50	%FSR	$T_{MIN} \leq T_A \leq T_{MAX}$
Integral Linearity Error					Note 1
-K		± 0.35	± 0.75	LSB	
Differential Linearity Error					
-K		± 0.35	± 0.95	LSB	
No Missing Codes	Guaranteed				
Unipolar Zero					Externally adjustable to zero
-K		± 1	± 5	LSB	$T_{MIN} \leq T_A \leq T_{MAX}$
INTERNAL REFERENCE					
Voltage Output	1.1440	1.2043	1.2645	V	
Output Source Current		100		μA	
Output Resistance		280		Ω	
AC PERFORMANCE					
SP8603					
Conversion Time		2.6		μs	$T_{MIN} \leq T_A \leq T_{MAX}$
Complete Cycle	3.0			μs	
Throughput Rate			333	kHz	
Spurious-Free Dynamic Range					Note 2
@ 49kHz		85		dB	
@ 161kHz		72		dB	
Total Harmonic Distortion					Note 2
@ 49kHz		-81		dB	
@ 161kHz		-71		dB	
Signal to Noise Ratio (SNR)					Note 2
@ 49kHz		72		dB	
@ 161kHz		72		dB	
Signal to (Noise + Distortion) Ratio					Note 2
@ 49kHz		71		dB	
@ 161kHz		68		dB	
SP8605					
Conversion Time		4.5		μs	
Complete Cycle	5.0			μs	
Throughput Rate			200	kHz	
Spurious-Free Dynamic Range					Note 2
@ 49kHz		85		dB	
@ 97kHz		77		dB	
Total Harmonic Distortion					Note 2
@ 49kHz		-81		dB	
@ 97kHz		-76		dB	

SPECIFICATIONS

(T_A = 25°C; Sampling Frequency, F_s = 333kHz for SP8603, 200kHz for SP8605, 100kHz for SP8610, V_S = +5V, unless otherwise specified.)

PARAMETER	MIN.	TYP.	MAX.	UNITS	CONDITIONS
AC PERFORMANCE					
SP8605					
Signal to Noise Ratio (SNR) @ 49kHz		72		dB	T _{MIN} ≤ T _A ≤ T _{MAX} Note 2
@ 97kHz		72		dB	
Signal to (Noise + Distortion) Ratio @ 49kHz		71		dB	Note 2
@ 97kHz		70		dB	
SP8610					
Conversion Time		9.5		μs	
Complete Cycle	10.0			μs	
Throughput Rate			100	kHz	
Spurious-Free Dynamic Range		85		dB	@ 49kHz; Note 2
Total Harmonic Distortion		-81		dB	@ 49kHz; Note 2
Signal to Noise Ratio (SNR)		72		dB	@ 49kHz; Note 2
Signal to (Noise + Distortion) Ratio		71		dB	@ 49kHz; Note 2
SAMPLING DYNAMICS					
Aperture Delay		13		ns	
Aperture Jitter		150		ps, rms	
Transient Response -K		150		ns	Note 3
Overvoltage Recovery		150		ns	Note 4
DIGITAL INPUTS					
Logic Levels					
V _{IL}	-0.3		+0.8	V	
V _{IH}	+2.4		+5.3	V	
I _{IL}		±0.1	±50	μA	
I _{IH}			±5	μA	
DIGITAL OUTPUTS					
Resolution	12			Bits	
Data Format	Parallel; 12-bit or 8-bit/4-bit				
Data Coding	Binary				
V _{OL}	0.0		+0.4	V	I _{SINK} = 1.6mA I _{SOURCE} = 1.6mA
V _{OH}	+2.4		V _{DD}	V	
I _{LEAKAGE} (High-Z State)		±0.1	±5	μA	
POWER SUPPLY REQUIREMENTS					
Rated Voltage	+4.75	+5.0	+5.25	V	V _S (V _{SA} and V _{SD})
Current		18	21	mA	I _S
Power Consumption		90		mW	
ENVIRONMENTAL AND MECHANICAL					
Specification -K	0		+70	°C	
Storage Package	-65		+150	°C	
-KN	28-pin Narrow DIP				
-KS	28-pin SOIC				

NOTES

1. LSB means Least Significant Bit. For **SP86xx Series**, 1LSB = 1.22mV for 5V range, 1 LSB = 2.44mV for 10V range.
2. All specifications in dB are referred to a full-scale input, either 10V or 5V.
3. For full-scale step input, 12-bit accuracy attained in specified time.
4. Recovers to specified performance in specified time after 2 x F_s input overvoltage.

PINOUT

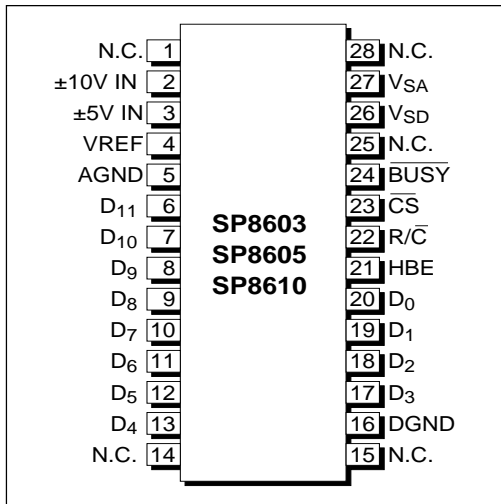

PIN ASSIGNMENT

Pin 1 — No Connection — This pin is not internally connected.

Pin 2 — IN₁ — 0V to 10V Analog Input. Connected to AGND for 10V range.

Pin 3 — IN₂ — 0V to 5V Analog Input. Connected to AGND for 5V range.

Pin 4 — V_{REF} — Internal Voltage. Reference Output.

Pin 5 — AGND — Analog Ground. Connect to pin 16 at the device.

Pin 6 — D₁₁ — Data Bit 11. Most Significant Bit (MSB).

Pin 7 — D₁₀ — Data Bit 10.

Pin 8 — D₉ — Data Bit 9.

Pin 9 — D₈ — Data Bit 8.

Pin 10 — D₇ — Data Bit 7 if HBE is LOW; LOW if HBE is HIGH.

Pin 11 — D₆ — Data Bit 6 if HBE is LOW; LOW if HBE is HIGH.

Pin 12 — D₅ — Data Bit 5 if HBE is LOW; LOW if

HBE is HIGH.

Pin 13 — D₄ — Data Bit 4 if HBE is LOW; LOW if HBE is HIGH.

Pin 14 — N.C. — This pin is not internally connected.

Pin 15 — N.C. — This pin is not internally connected.

Pin 16 — DGND — Digital Ground. Connect to pin 5 at the device.

Pin 17 — D₃ — Data Bit 3 if HBE is LOW; Data Bit 11 if HBE is HIGH.

Pin 18 — D₂ — Data Bit 2 if HBE is LOW; Data Bit 10 if HBE is HIGH.

Pin 19 — D₁ — Data Bit 1 if HBE is LOW; Data Bit 9 if HBE is HIGH.

Pin 20 — D₀ — Data Bit 0 if HBE is LOW. Least Significant Bit (LSB). Data Bit 8 if HBE is HIGH.

Pin 21 — HBE — High Byte Enable, When held LOW, data output as 12-bits in parallel. When held HIGH, four MSBs presented on pins 17–20, pins 10–13 output LOWs. Must be LOW to initiate conversion.

Pin 22 — R/C — Read/Convert. Falling edge initiates conversion when CS is LOW, HBE is LOW, and BUSY is HIGH.

Pin 23 — CS — Chip Select. Outputs in Hi-Z state when HIGH. Must be LOW to initiate conversion or read data.

Pin 24 — BUSY — Output LOW during conversion. Data valid on rising edge in Convert Mode.

Pin 25 — N.C. — This pin is not internally connected.

Pin 26 — V_{SD} — Positive Digital Power Supply, +5V. Connect to pin 27, and bypass to DGND.

Pin 27 — V_{SA} — Positive Analog Power Supply. +5V. Connect to pin 26, and bypass to AGND.

Pin 28 — N.C. — This pin is not internally connected.

FEATURES...

The **SP86XX Series** are specified at sampling rates of 333kHz (**SP8603**), 200kHz (**SP8605**) or 100kHz (**SP8610**). Conversion times are factory set for 2.70 μ s, 4.7 μ s and 9.7 μ s maximum, respectively, over temperature, and the high-speed sampling input stage insures a total acquisition and conversion time of 3 μ s, 5 μ s and 10 μ s maximum, respectively, over temperature. Precision, laser-trimmed scaling resistors provide industry-standard input ranges of 0V to +5V or 0V to +10V.

The 28-pin **SP86XX Series** are available in narrow plastic DIP, and SOIC packages and it operates from a single +5V supply. The **SP86XX Series** are available in grades specified over the 0°C to +70°C commercial temperature ranges.

OPERATION

Basic Operation

Figure 1 shows the simple hookup circuit required to operate the **SP86XX Series** in a 0V to +10V range in the Convert Mode. A convert command arriving on R/ \bar{C} puts the **SP86XX Series** in the HOLD mode, and a conversion is started. This pulse must be LOW for a minimum of 40ns. Because this pulse establishes the sampling instant of the A/D, it must have very low jitter. \overline{BUSY} will be held LOW during the conversion, and rises only

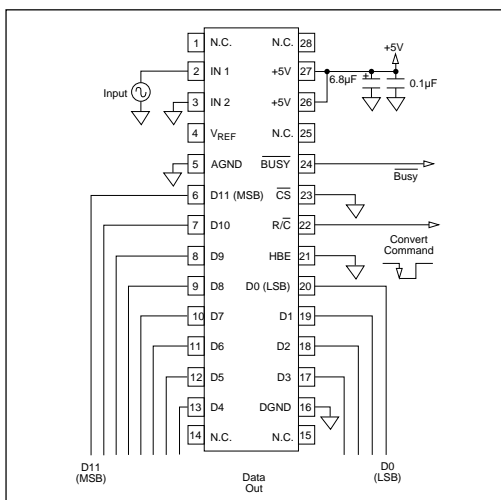

Figure 1. Basic 0V to 10V Operation

after the conversion is completed and the data has been transferred to the output drivers. Thus, the rising edge can be used to read the data from the conversion. Also, during conversion, the \overline{BUSY} signal puts the output data lines in Hi-Z states and inhibits the input lines. This means that pulses on R/ \bar{C} are ignored, so that new conversions cannot be initiated during a conversion.

The **SP86XX Series** will begin acquiring a new sample just prior to the \overline{BUSY} output rising, and will track the input signal until the next conversion is started.

In the Read Mode, R/ \bar{C} is kept normally LOW, and a HIGH pulse is used to read data and initiate a conversion. In this mode, the rising edge of R/ \bar{C} will enable the output data pins, and the data from the previous conversion becomes valid. The falling edge then puts the **SP86XX Series** in a hold mode, and initiates a new conversion.

For use with an 8-bit bus, the data can be read out in two bytes under the control of HBE. With a LOW input on HBE, at the end of a conversion, the 8 LSBs of data are loaded into the output drivers on D₇ through D₄ and D₃ through D₀. Taking HBE HIGH then loads the 4 MSBs on D₃ through D₀, with D₇ through D₄ being forced LOW.

Analog Input Ranges

The **SP86XX Series** offers two standard unipolar input ranges: 0V to +10V and 0V to +5V. If a 10V unipolar range is required, the analog input signal should be connected to pin 2. A signal requiring a 5V unipolar range should be connected to pin 3. In either case, the other pin of the two must be grounded or connected to the adjustment circuits described in the section on calibration.

Controlling The SP86XX Series

The **SP86XX Series** can be easily interfaced to most microprocessor-based and other digital systems. The microprocessor may take full control of each conversion, or the **SP86XX Series** may operate in a stand-alone mode, controlled only by the R/ \bar{C} input. Full control consists of initiating the conversion and reading the output data at user command, transmitting data either all 12-bits in one parallel word, or in two 8-bit bytes. The three control inputs (CS, R/ \bar{C} and HBE) are all TTL/CMOS compatible. The functions of the

CS	R/C	HBE	BUSY	OPERATION
1	X	X	1	None – outputs in Hi-Z state.
0	1 \downarrow 0	0	1	Holds signal and initiates conversion.
0	1	0	1	Output three-state buffers enabled once conversion has finished.
0	1	1	1	Enable hi-byte in 8-bit bus mode.
0	1 \downarrow 0	1	1	Inhibit start of conversion.
0	0	1	1	None – outputs in Hi-Z state.
X	X	X	0	Conversion in progress. Outputs Hi-Z state. New conversion inhibited until present conversion has finished.

Table 1. Control Line Functions

control lines are shown in *Table 1*.

For stand-alone operation, control of the **SP86XX Series** is accomplished by a single control line connected to R/C. In this mode, CS and HBE are connected to GND. The output data are presented as 12-bit words. The stand-alone mode is used in systems containing dedicated input ports which do not require full bus interface capability.

Conversion is initiated by a HIGH-to-LOW transition on R/C. The three-state data output buffers are enabled when R/C is HIGH and BUSY is HIGH. Thus, there are two possible modes of operation: conversion can be initiated with either positive or negative pulses. In either case, the R/C pulse must remain LOW a minimum of 40ns.

Figure 5 illustrates timing when conversion is initiated by an R/C pulse which goes LOW and returns HIGH during the conversion. In this case (Convert Mode), the three-state outputs go into the Hi-Z state in response to the falling edge of R/C, and are enabled for external access to the data after completion of the conversion.

Figure 6 illustrates the timing when conversion is initiated by a positive R/C pulse. In this mode (Read Mode), the output data from the previous conversion is enabled during the HIGH portion of R/C, and a new conversion starts on the falling edge of R/C, and the three-state outputs return to the Hi-Z state until the next occurrence of a HIGH on R/C.

Conversion Start

A conversion is initiated on the **SP86XX Series** only by a negative transition occurring on R/C, as shown

in *Table 2*. No other combination of states or transitions will initiate a conversion. Conversion is inhibited if either CS or HBE are HIGH, or if BUSY is LOW. CS and HBE should be stable a minimum of 25ns prior to the transition on R/C. Timing relationships for start of conversion are illustrated in *Figure 7*.

The BUSY output indicates the current state of the converter by being LOW only during conversion. During this time the three-state output buffers remain in a Hi-Z state, and therefore data cannot be read during conversion. During this period, additional transitions on the three digital inputs (CS, R/C and HBE) will be ignored, so that conversion cannot be prematurely terminated or restarted.

Internal Clock

The **SP86XX Series** has an internal clock that is factory trimmed to achieve the typical conversion times given in the specifications, and a maximum conversion time over the full operating temperature range of 2.7µs, 4.7µs or 9.7µs, depending on the model. No external adjustments are required, and with the guaranteed maximum acquisition time of 300ns, throughput performance is assured with convert pulses as close as 3µs for the **SP8603**.

Reading Data

After conversion is initiated, the output buffers remain in a Hi-Z state until the following three logic conditions are simultaneously met: R/C is HIGH, BUSY is HIGH and CS is LOW. Upon satisfying these conditions, the data lines are enabled according to the state of HBE. See *Figure 7* for timing relationships and specifications.

CALIBRATION...

Optional External Gain And Offset Trim

Offset and full-scale errors may be trimmed to zero using external offset and full-scale trim potentiometers connected to the **SP86XX Series** as shown in *Figure 3*.

If adjustment of offset and full scale is not required,

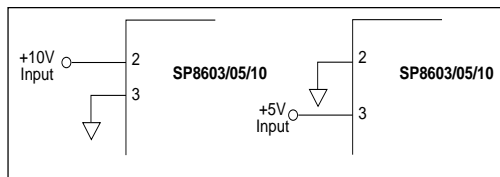

Figure 2. a) 10V Range b) 5V Range — Without Trims

INPUT VOLTAGE RANGE AND LSB VALUES			
Input Voltage Range Defined As:		0V to +10V	0V to +5V
Analog Input Connected to Pin		2	3
Pin Connected to AGND		3	2
One Least Significant Bit (LSB)	$FSR/2^{12}$	$10V/2^{12}$ 2.44mV	$5V/2^{12}$ 1.22mV
OUTPUT TRANSITION VALUES			
FFE _H TO FFF _H	+ FULL SCALE	+10V-3/2LSB +9.963V	+5V-3/2LSB +4.9982V
7FF _H TO 800 _H	Mid Scale	4.9988V	2.4994V
000 _H to 001 _H	0V	1.22mV	0.6mV

Table 2. Input Voltages, Transition Voltages and LSB Values

connections as shown in Figure 2 should be used.

Calibration Procedure

Apply a precision input voltage source to your chosen input range (10V range at pin 2 or 5V at pin 3). Set the A/D to convert continuously. Monitor the output code. Trim the offset first, then gain. Use the appropriate input voltages and output target codes for your chosen input range as follows. The recommended offset calibration voltage values eliminate interaction between the offset and gain calibration

$$FFE_H = 4094_{DEC}$$

+10V Range Offset and Gain

Offset — Apply 0.0012V to the +10V input at pin 2. Adjust the offset potentiometer until the LSB toggles on and off at code 0000 0000 0000_{BIN} = 000_H = 0000_{DEC}.

Gain — Apply 9.9963V to the +10V input at pin 2. Adjust the gain potentiometer until the LSB toggles on and off at code 1111 1111 1110_{BIN} = FFE_H = 4094_{DEC}.

+5V Range Offset and Gain

Offset — Apply 0.0006V to the +5V input at pin 3. Adjust the offset potentiometer until the LSB toggles on and off at code 0000 0000 0000_{BIN} = 000_H = 0000_{DEC}.

Gain — Apply 4.9982V to the +5V input at pin 3. Adjust the gain potentiometer until the LSB toggles on and off at code 1111 1111 1110_{BIN} =

Layout Considerations

Because of the high resolution and linearity of the **SP86XX Series**, system design problems such as ground path resistance and contact resistance become very important.

The input resistance of the **SP86XX Series** is 6.3k Ω or 4.2k Ω (for the 10V and 5V ranges respectively).

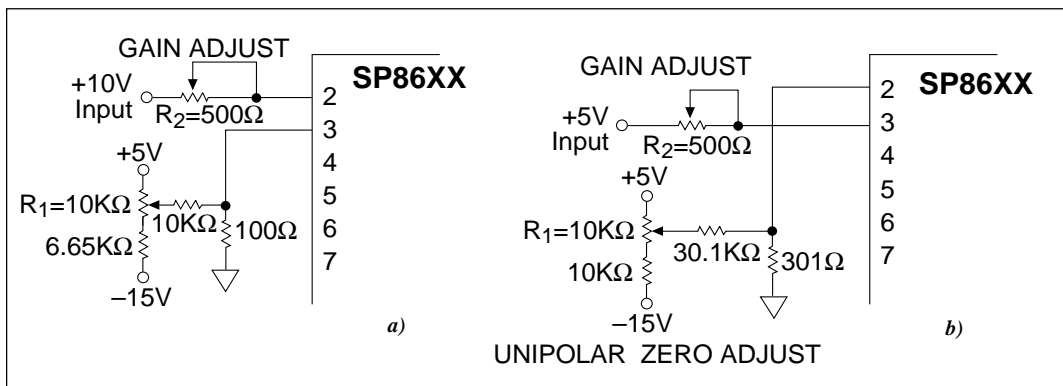

Figure 3. a) 10V Range b) 5V Range — With External Trims

To avoid introducing distortion, the source resistance must be very low, or constant with signal level. The output impedance provided by most op amps is ideal. Pins 26 Digital Supply Voltage (V_{SD}) and 27 Analog Supply Voltage (V_{SA}) are brought out to separate pins to maximize accuracy on the chip. They should be connected together as close as possible to the unit. Pin 27 may be slightly more sensitive than pin 26 to supply variations, but to maintain maximum system accuracy, both should be well-isolated from digital supplies with wide load variations.

To limit the effects of digital switching elsewhere in a system on the analog performance of the system, it often makes sense to run a separate +5V supply conductor from the supply regulator to any analog components requiring +5V, including the **SP86XX Series**. If the **SP86XX Series** traces cannot be separated back to the power supply terminals, and therefore share the same trace as the logic supply currents, then a 10 Ohm isolating resistor should be used between the board supply and pin 24 (V_{DA}) and its bypass capacitors to keep V_{DA} glitch-free. The V_S pins (26 and 27) should be connected together and bypassed with a parallel combination of a 6.8 μ F Tantalum capacitor and a 0.1 μ F ceramic capacitor located close to the converter to obtain noise-free operation. (See *Figure 1*). Noise on the power supply lines can degrade converter performance, especially noise and spikes from a switching power supply. Appropriate supplies or filters must be used.

The GND pins (5 and 16) are also separated internally, and should be directly connected to a ground plane under the converter. A ground plane is usually the best solution for preserving dynamic performance and reducing noise coupling into sensitive converter circuits. Where any compromises must be made, the common return of the analog input signal should be referenced to pin 5, AGND, on the **SP86XX Series**, which prevents any voltage drops that might occur in the power supply common returns from appearing in series with the input signal.

Coupling between analog input and digital lines should be minimized by careful layout. For instance, if the lines must cross, they should do so at right angles. Parallel analog and digital lines should be separated from each other by a pattern connected to common.

If external full scale and offset potentiometers are used, the potentiometers and related resistors should be located as close to the **SP86XX Series** as possible.

“Hot Socket” Precaution

Two separate +5V V_S pins, 26 and 27, are used to minimize noise caused by digital transients. If one pin is powered and the other is not, the **SP86XX Series** may draw excessive current. In normal operation, this is not a problem because both pins will be soldered together. However, during evaluation, incoming inspection, repair, etc., where the potential of a “Hot Socket” exists, care should be taken to apply power to

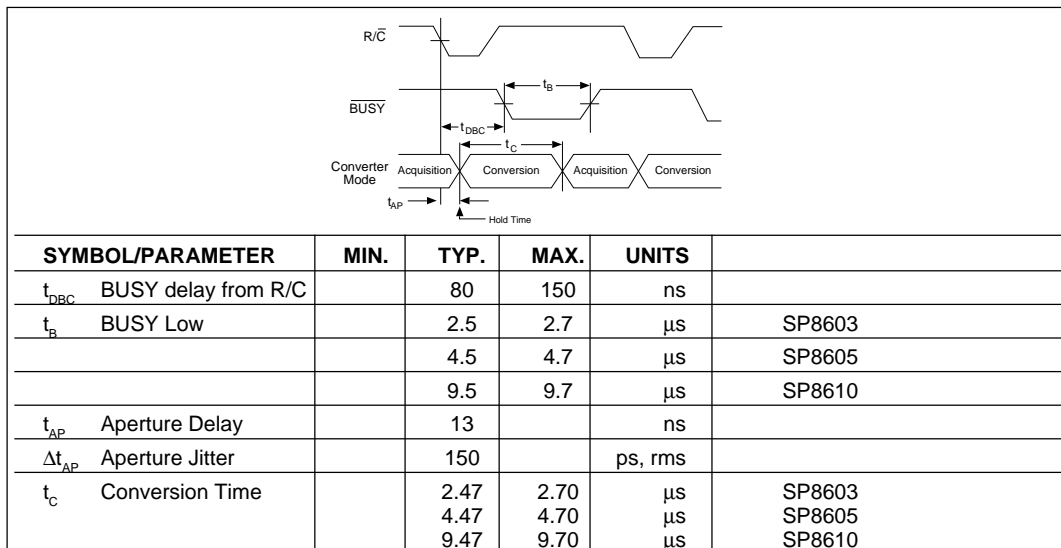

Figure 4. Acquisition and Conversion Timing

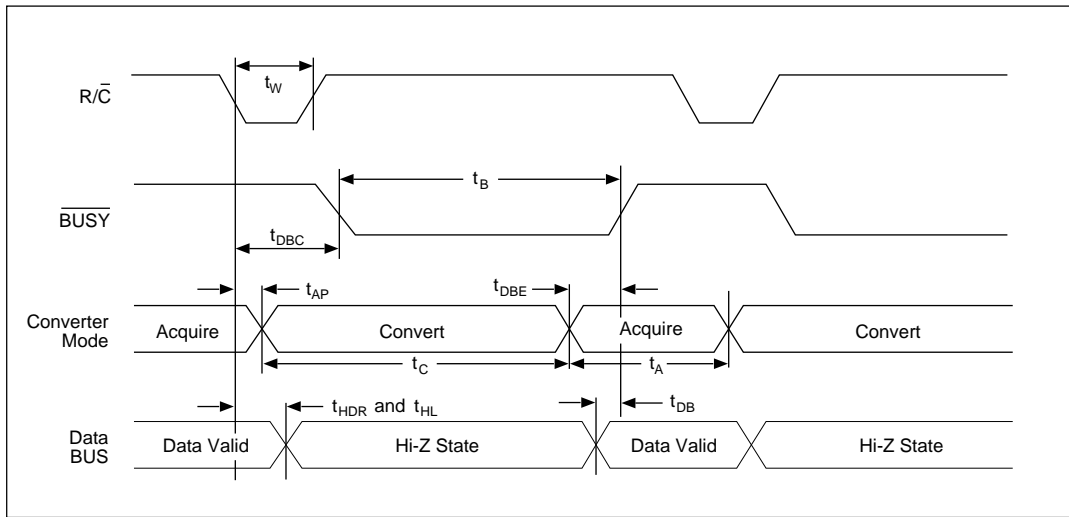

Figure 5. Convert Mode Timing — R/\bar{C} Pulse LOW, Outputs Enabled After Conversion

the **SP86XX Series** only after it has been socketed.

Minimizing “Glitches”

Coupling of external transients into an analog-to-digital converter can cause errors which are difficult to debug. In addition to the discussions earlier on layout considerations for supplies, bypassing and grounding, there are several other useful steps that can be taken to get the best analog performance out of a system using the **SP86XX Series**. These potential system problem sources are particularly important to consider when developing a new system, and looking for the causes of errors in breadboards.

First, care should be taken to avoid glitches during critical times in the sampling and conversion process. Since the **SP86XX Series** has an internal sample/hold function, the signal that puts it into the hold state (R/\bar{C} going LOW) is critical, as it would be on any sample/hold amplifier. The R/\bar{C} falling edge should have a 5 to 10ns transition time, low jitter, and have minimal ringing, especially during the 20ns after it falls.

Although not normally required, it is also good practice to avoid glitches from coupling to the **SP86XX Series** while bit decisions are being made. Since the above discussion calls for a fast, clean rise and fall on

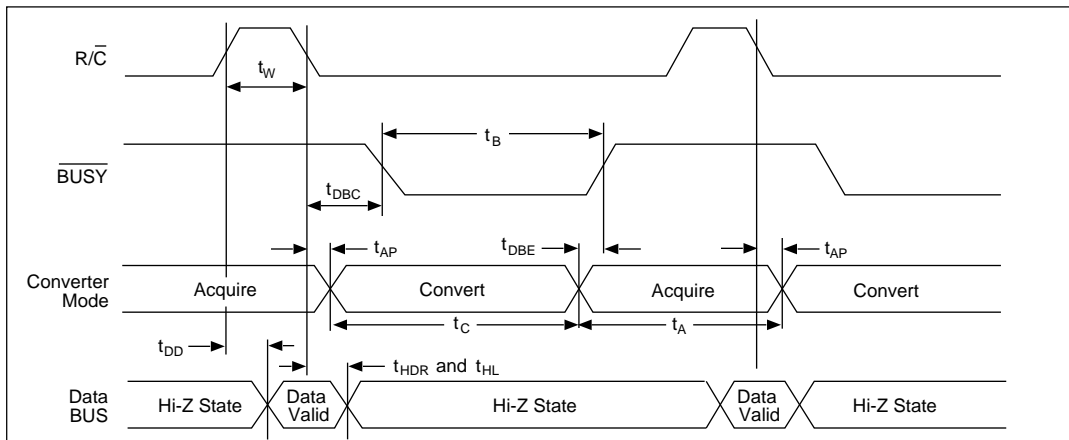

Figure 6. Read Mode Timing — R/\bar{C} Pulse HIGH, Outputs Enabled Only When R/\bar{C} is High

AC DYNAMIC TIMING DATA

SYMBOL/PARAMETER	MIN .	TYP.	MAX.	UNITS
t_W $\overline{R/C}$ Pulse Width	40			ns
t_{DBC} \overline{BUSY} delay from $\overline{R/C}$		80	150	ns
t_B \overline{BUSY} LOW		2.47	2.7	μ s
t_{AP} Aperture Delay		13		ns
Δt_{AP} Aperture Jitter		150		ps, rms
t_C Conversion Time		2.5	2.70	μ s
t_{DBE} \overline{BUSY} from End of Conversion		100		ns
t_{DB} \overline{BUSY} Delay after Data Valid	25	75	200	ns
t_A Acquisition Time		130	300	ns
$t_A + t_C$ Throughput Time				
SP8603	3.0			μ s
SP8605	5.0			μ s
SP8610	10.0			μ s
t_{HDR} Valid Data Held After $\overline{R/C}$ LOW	20	50		ns
t_S \overline{CS} or HBE LOW before $\overline{R/C}$ Falls	25	5		ns
t_H \overline{CS} or HBE LOW after $\overline{R/C}$ Falls	25	0		ns
t_{DD} Data Valid from \overline{CS} LOW, $\overline{R/C}$ HIGH, and HBE in Desired State (Load = 100pF)		65	150	ns
t_{HL} Delay to Hi-Z State after $\overline{R/C}$ Falls or \overline{CS} Rises (3K Ω Pullup or Pulldown)		50	150	ns
All parameters Guaranteed By Design.				

$\overline{R/C}$, it makes sense to keep the rising edge of the convert pulse outside the time when bit decisions are being made. In other words, the convert pulse should either be short (under 100ns so that it transitions before the MSB decision), or relatively long (i.e., for the **SP8603**, over 2.75 μ s to transition after the LSB decision).

Next, although the data outputs are forced into a Hi-Z state during conversion, fast bus transients can still be capacitively coupled into the **SP86XX Series**. If the data bus experiences fast transients during conversion, these transients can be attenuated by adding a logic buffer to the data outputs. The \overline{BUSY} output can be used to enable the buffer.

Naturally, transients on the analog input signal are to be avoided, especially at times within ± 20 ns of $\overline{R/C}$ going LOW, when they may be trapped as part of the charge on the capacitor array. This requires careful

layout of the circuit in front of the **SP86XX Series**.

Finally, in multiplexed systems, the timing relative to when the multiplexer is switched may affect the analog performance of the system. In most applications, the multiplexer can be switched as soon as $\overline{R/C}$ goes LOW (with appropriate delays), but this may affect the conversion if the switched signal shows glitches or significant ringing at the **SP86XX Series** input. Whenever possible, it is safer to wait until the conversion is completed before switching and multiplexer. The extremely fast acquisition time and conversion time of the **SP86XX Series** make this practical in many applications.

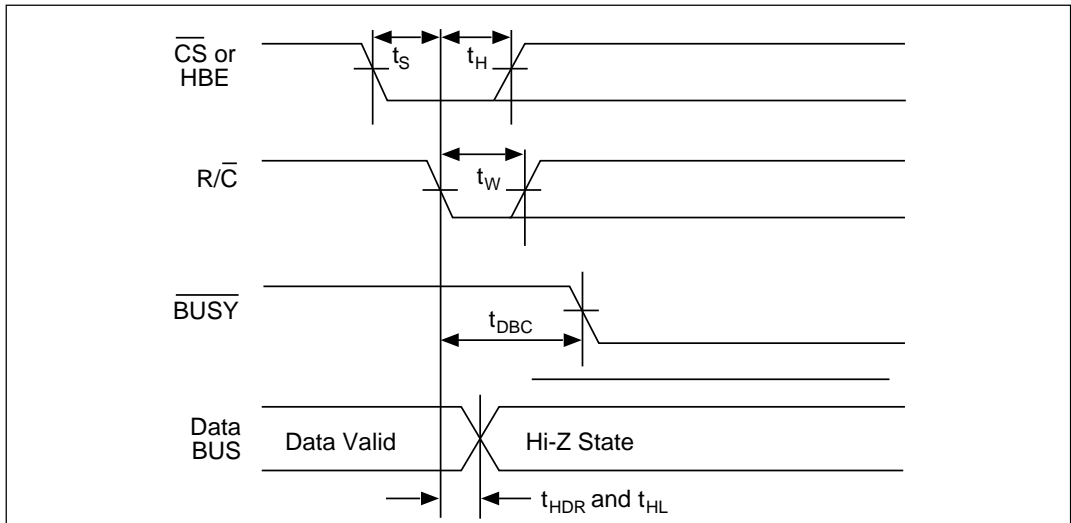

Figure 7. Conversion Start Timing

ORDERING INFORMATION

0°C to +70°C

Model	Throughput	Package
SP8603KN	333kHz	28-pin, 0.3" Plastic DIP
SP8603KS	333kHz	28-pin, 0.3" SOIC
SP8605KN	200kHz	28-pin, 0.3" Plastic DIP
SP8605KS	200kHz	28-pin, 0.3" SOIC
SP8610KN	100kHz	28-pin, 0.3" Plastic DIP
SP8610KS	100kHz	28-pin, 0.3" SOIC