

SPEED REGULATOR FOR DC MOTORS

- MATCHING FLEXIBILITY TO MOTORS WITH VARIOUS CHARACTERISTICS
- BUILT-IN CURRENT LIMIT
- ON-CHIP 1.2V REFERENCE VOLTAGE
- STARTING CURRENT: 0.5 A @ 2.5V
- REFLECTION COEFFICIENT $K = 20$

DESCRIPTION

The TDA1154 is a monolithic integrated circuit intended for speed regulation of permanent magnet dc motors used in record players, tape recorders, cassette recorders and toys.

The circuit offers an excellent speed regulation with much higher power supply, temperature and load variations than conventional circuits built around discrete components.

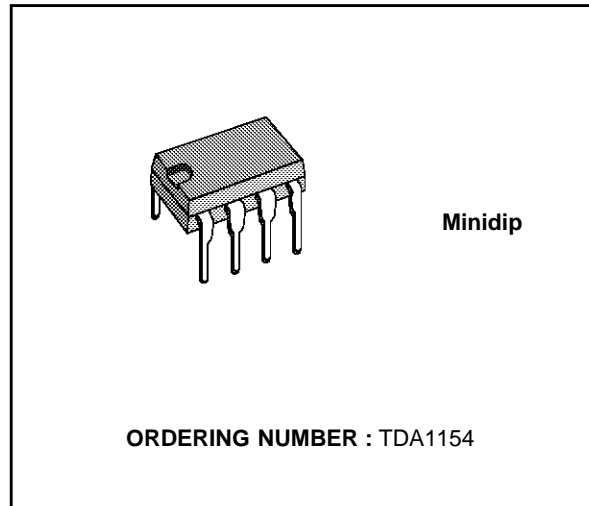
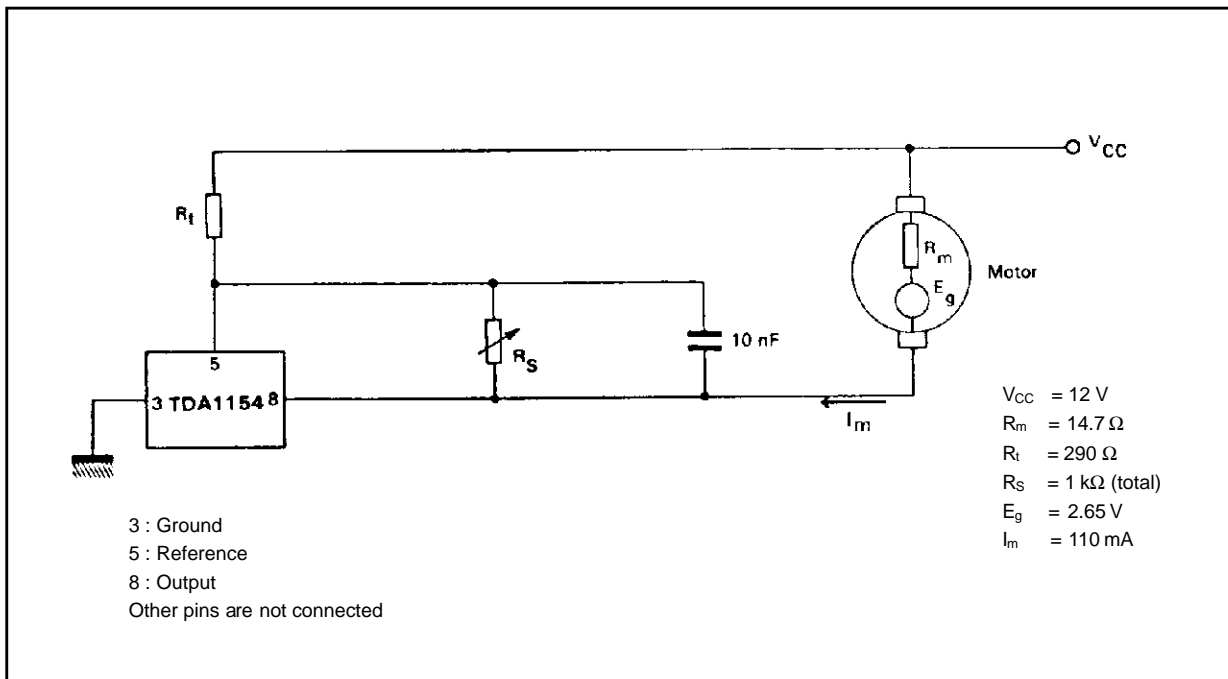
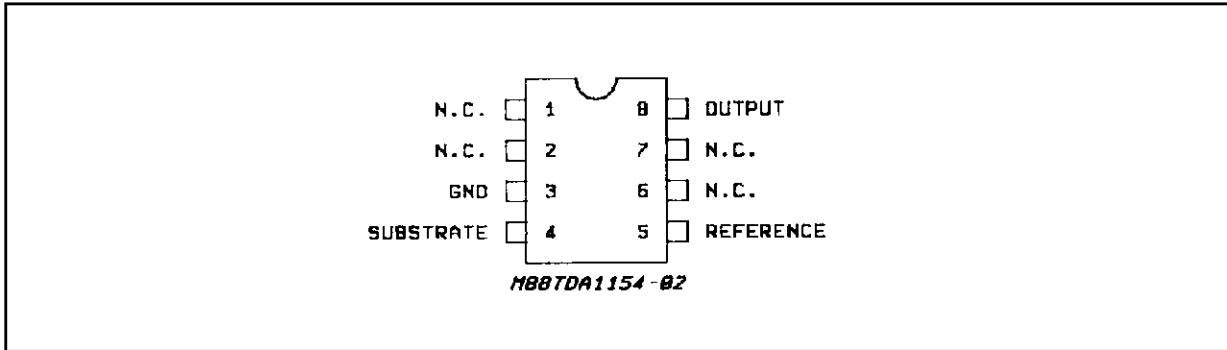

Figure 1. Application circuit



TDA1154

PIN CONNECTION (Top view)



ABSOLUTE MAXIMUM RATINGS

Symbol	Parameter	Value	Unit
V_{CC}	Supply voltage	20	V
I_o	Output current	1.2	A
P_{tot}	Power dissipation	(see curve)	W
T_j	Junction temperature	+150	°C
T_{stg}	Storage temperature range	-55 to +150	°C

Figure 2. Test circuit

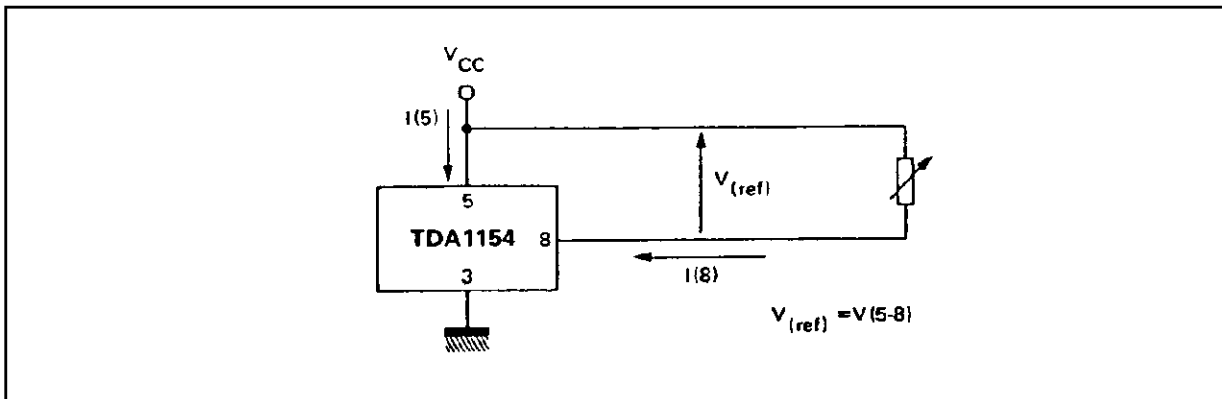

THERMAL DATA

Symbol	Parameter	Value	Unit
$R_{th-j-amb}$	Thermal resistance junction-ambient	max 100	°C/W
$R_{th-j-pin 4}$	Thermal resistance junction-pin 4	max 70	°C/W

ELECTRICAL CHARACTERISTICS $T_{amb} = +25\text{ }^{\circ}\text{C}$ (Unless otherwise specified)

Symbol	Parameter	Test Conditions	Min.	Typ.	Max.	Unit
$V_{(ref)}$	Reference voltage	$V_{CC} = +6V$ $I(8) = 0.1A$	1.15	1.25	1.35	V
$\frac{\Delta V_{(ref)}}{V_{(ref)}} / \Delta T$	Reference voltage temperature coefficient	$V_{CC} = +6V$ $I(8) = 0.1A$ $T_{amb} = -20^{\circ}\text{C}$ to $+70^{\circ}\text{C}$	-	0.02	-	%/ $^{\circ}\text{C}$
$\frac{\Delta V_{(ref)}}{V_{(ref)}} / \Delta V_{CC}$	Line regulator	$V_{CC} = +4V$ to $+18V$ $I(8) = 0.1A$	-	0.02	-	%/V
$\frac{\Delta V_{(ref)}}{V_{(ref)}} / \Delta I(8)$	Load regulator	$V_{CC} = +6V$ $I(8) = 25$ to 400 mA	-	0.009	-	%/mA
$V(5 - 3)$	Minimum supply voltage	$I(8) = 0.1A$ $\frac{\Delta V_{(ref)}}{V_{(ref)}} = -5\%$	2.5	-	-	V
$I(8)$	Starting current(*)	$\frac{\Delta V_{(ref)}}{V_{(ref)}} = -50\%$ $V_{CC} = +5V$ $V_{CC} = +2.5V$	1.2 0.5	- 0.8	- -	A
$I_o(5)$	Quiescent current on pin 5	$V_{CC} = +6V$ $I(8) = 100\text{ }\mu\text{A}$	-	1.7	-	mA
K	$K = \frac{\Delta I(8)}{\Delta I(5)}$ reflection coefficient	$V_{CC} = +6V$ $I(8) = 0.1A$	18	20	22	
$\frac{\Delta K}{K} / \Delta V_{CC}$	K spread versus V_{CC}	$V_{CC} = +6V$ to $+18V$ $I(8) = 0.1A$	-	0.45	-	%/V
$\frac{\Delta K}{K} / \Delta I(8)$	K spread versus $I(8)$	$V_{CC} = +6V$ $I(8) = 25$ to 400 mA	-	0.005	-	%/mA
$\frac{\Delta K}{K} / \Delta T$	K spread versus temperature	$V_{CC} = +6V$ $I(8) = 0.1A$ $T_{amb} = +20^{\circ}\text{C}$ to $+70^{\circ}\text{C}$	-	0.02	-	%/ $^{\circ}\text{C}$

(*) An internal protection circuit reduces the current if the temperature of the junction increase: $I(8) = 0.75A$ at $T_j = +140\text{ }^{\circ}\text{C}$

OPERATING MODE

Figure 3

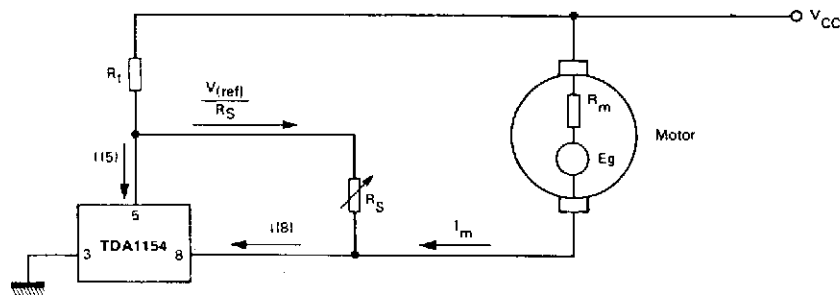

The circuit maintains a 1.2V constant reference voltage between pins 5 and 8:

$$V(5 - 8) = V_{(ref)} = 1.2V$$

The current $I(5)$ drawn by the circuit at pin 5 is

sum of two currents.

One is constant: $I_o(5) = 1.7\text{ mA}$ and the other is proportional to pin 8 current $I(8)$:

$$I(5) = I_o(5) + I(8)K(a) \quad (I_o(5) = 1.7\text{ mA}, K = 20)$$

TDA1154

If E_g and R_m are motor back electromotive force and motor internal resistance respectively, then:

$$E_g + R_m I_m = R_t \left[I(5) + \frac{V_{(ref)}}{R_s} \right] + V_{(ref)} \quad (b)$$

From figure 2 it is seen that:

$$I(8) = I_m + \frac{V_{(ref)}}{R_s} \quad (c)$$

Substituting equations (a) and (c) into (b) yields:

$$E_g = I_m \left[\frac{R_t}{K} - R_m \right] + \quad (1)$$

$$+ V_{(ref)} \left[\frac{R_t}{R_s} \left(1 + \frac{1}{K} \right) + 1 \right] + R_t I_o(5) \quad (d)$$

$$\quad (2)$$

The motor speed will be independent of the resisting torque if E_g is also independent of I_m . Therefore, in order to determine the value of R_t term(1) in (d) must be zero:

$$R_t = K R_m \quad (K=20)$$

If $R_t > K R_m$, an instability may occur as a result of overcompensation.

The value of R_s is determined by term (2) in (d) so as to obtain the back electromotive force (E_g) corresponding to required motor speed:

$$R_s = R_t \frac{V_{(ref)} (1 + 1/K)}{E_g - V_{(ref)} - R_t I_o(5)} \cong$$

$$\cong R_t \frac{V_{(ref)}}{E_g - V_{(ref)} - R_t I_o(5)}$$

Where $V_{(ref)} = 1.2V$ and $I_o(5) = 1.7 mA$

Figure 4. Application circuit

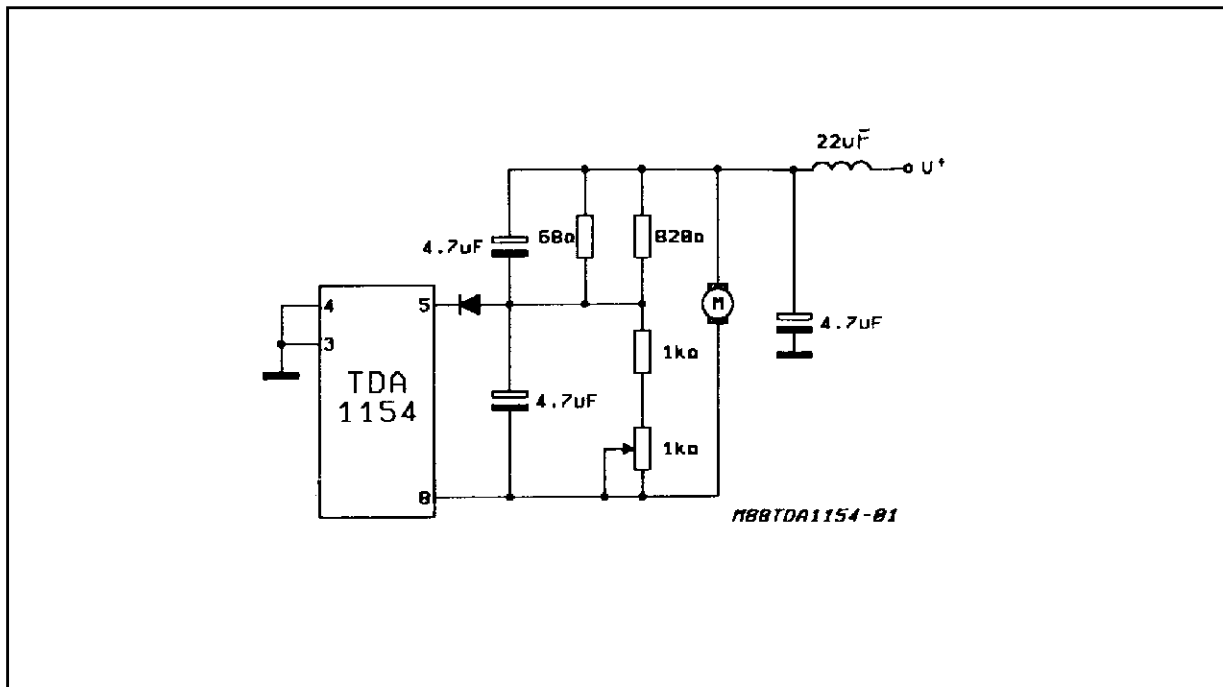

MINIDIP PACKAGE MECHANICAL DATA

DIM.	mm			inch		
	MIN.	TYP.	MAX.	MIN.	TYP.	MAX.
A		3.32			0.131	
a1	0.51			0.020		
B	1.15		1.65	0.045		0.065
b	0.356		0.55	0.014		0.022
b1	0.204		0.304	0.008		0.012
D			10.92			0.430
E	7.95		9.75	0.313		0.384
e		2.54			0.100	
e3		7.62			0.300	
e4		7.62			0.300	
F			6.6			0.260
I			5.08			0.200
L	3.18		3.81	0.125		0.150
Z			1.52			0.060

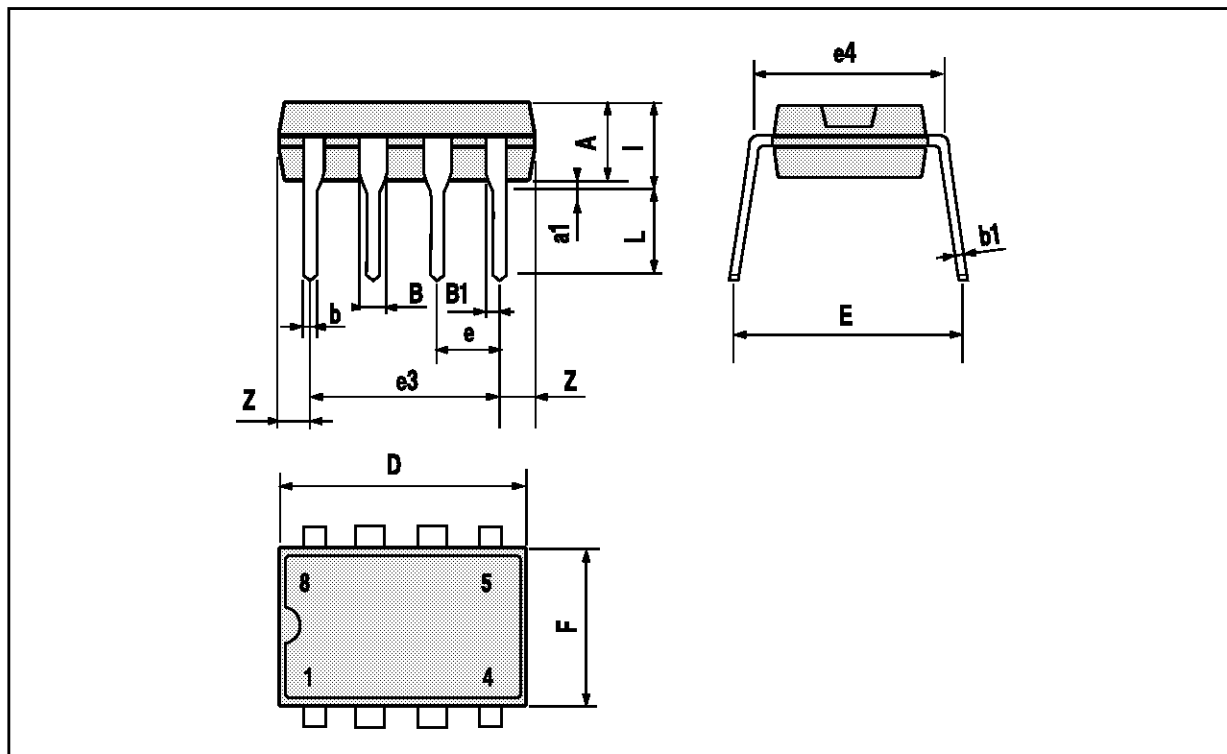

Information furnished is believed to be accurate and reliable. However, SGS-THOMSON Microelectronics assumes no responsibility for the consequences of use of such information nor for any infringement of patents or other rights of third parties which may result from its use. No license is granted by implication or otherwise under any patent or patent rights of SGS-THOMSON Microelectronics. Specifications mentioned in this publication are subject to change without notice. This publication supersedes and replaces all information previously supplied. SGS-THOMSON Microelectronics products are not authorized for use as critical components in life support devices or systems without express written approval of SGS-THOMSON Microelectronics.

© 1994 SGS-THOMSON Microelectronics - All Rights Reserved

SGS-THOMSON Microelectronics GROUP OF COMPANIES

Australia - Brazil - France - Germany - Hong Kong - Italy - Japan - Korea - Malaysia - Malta - Morocco - The Netherlands - Singapore - Spain - Sweden - Switzerland - Taiwan - Thailand - United Kingdom - U.S.A.