

## Two-phase Unipolar DC Brushless Motor Pre-Driver IC

### ◆ GENERAL DESCRIPTION

NJM2640 is a two phase unipolar DC brushes motor pre-driver IC. It features high voltage bipolar technology so that the driver works up to 48V. High voltage operation delivers more power and improves power supply efficiency. Therefore, it is suitable for high voltage fan motor applications.

### ◆ PACKAGE OUTLINE

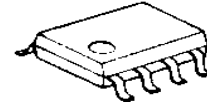

NJM2640E

### ◆ FEATURES

- Operating Supply Voltage  $V_{CC}=4$  to 55V
- Absolute Maximum Voltage 60V
- Internal Lock Protection /Auto Protection Release Circuit
- Lock Alarm Output Terminal
- Package Outline EMP8

### ◆ BLOCK DIAGRAM

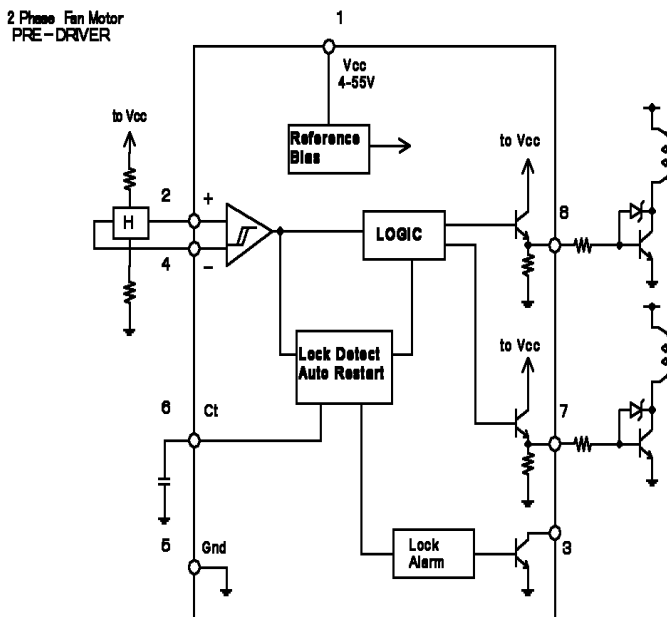

### ◆ PIN CONFIGURATIONS

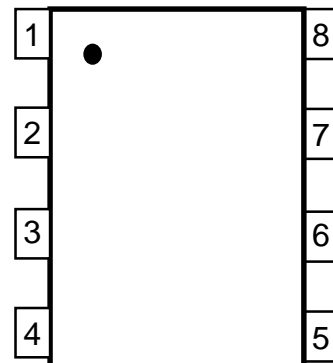

- 1 : Vcc
- 2 : H1
- 3 : LA
- 4 : H2
- 5 : GND
- 6 : Ct
- 7 : OUT1
- 8 : OUT2

# NJM2640

## ◆ ABSOLUTE MAXIMUM RATINGS(Ta=25°C)

PARAMETER	SYMBOL	RATINGS	UNIT
Supply Voltage	V <sub>CC</sub>	60	V
Hall Input Voltage Range	V <sub>IH</sub>	-0.3~V <sub>CC</sub>	V
Output Current	I <sub>OUT</sub>	30	mA
Lock Alarm Output Voltage	V <sub>OLA</sub>	60	V
Hall Input Differential Voltage	V <sub>IHD</sub>	2	V
Lock Alarm Output Current	I <sub>OLA</sub>	20	mA
Power Dissipation	P <sub>D</sub>	375	mW
Operating Temperature Range	T <sub>opr</sub>	-40~85	°C
Operating Junction Temperature Range	T <sub>oj</sub>	-40~150	°C
Storage Temperature Range	T <sub>stg</sub>	-55~150	°C

## ◆ ELECTRICAL CHARACTERISTICS(V<sub>CC</sub>=48V, Ta=25°C)

PARAMETER	SYMBOL	TEST CONDITIONS	NIN..	TYP.	MAX.	UNIT
Operating Supply Voltage Range	V <sub>CC</sub>	-	4.0	48.0	55.0	V
Operating Current	I <sub>CC</sub>	V <sub>CC</sub> =24V	-	3.0	4.0	mA
		V <sub>CC</sub> =48V	-	3.8	4.8	mA
Hall Input Hysterisis Range	V <sub>HYS</sub>	-	8	20	32	mV
Hall Amplifier Input Bias Current	I <sub>B</sub>	-	-	0.5	1.0	μA
Hall Input Common mode Voltage	V <sub>ICM</sub>	-	1.5	-	V <sub>CC</sub> -2	V
Output Voltage	V <sub>OUT</sub>	I <sub>OUT</sub> =10mA	-	V <sub>CC</sub> -1.5	-	V
Output Leak Current	I <sub>LEAK</sub>	V <sub>CC</sub> =60V	-	-	5	μA
Lock Alarm Output Voltage	V <sub>LA</sub>	Lock Alarm ON, I <sub>LA</sub> =5mA	-	-	0.5	V
Lock Alarm Leak Current	I <sub>LA-LEAK</sub>	V <sub>LA</sub> =60V	-	-	10	μA
Ct Charge Current	I <sub>CHG</sub>	V <sub>Ct</sub> =1.5V	-	3.8	-	μA
Ct Discharge Current	I <sub>DCHG</sub>	V <sub>Ct</sub> =1.5V	-	0.75	-	μA
Charge / Discharge Current Ratio	I <sub>CHG</sub> / I <sub>DCHG</sub>	-	4.0	5.5	8.0	
Ct H level Cense Voltage	V <sub>CtH</sub>	-	2.2	2.5	2.8	V
Ct L level Cense Voltage	V <sub>CtL</sub>	-	0.6	0.7	0.8	V
Auto Protection Release ON Time	T <sub>ON</sub>	Ct=0.47μF	-	0.25	-	s
Auto Protection Release OFF Time	T <sub>OFF</sub>	Ct=0.47μF	-	1.25	-	s

## ◆ TYPICAL CHARACTERISTICS

### ICC VS. VCC

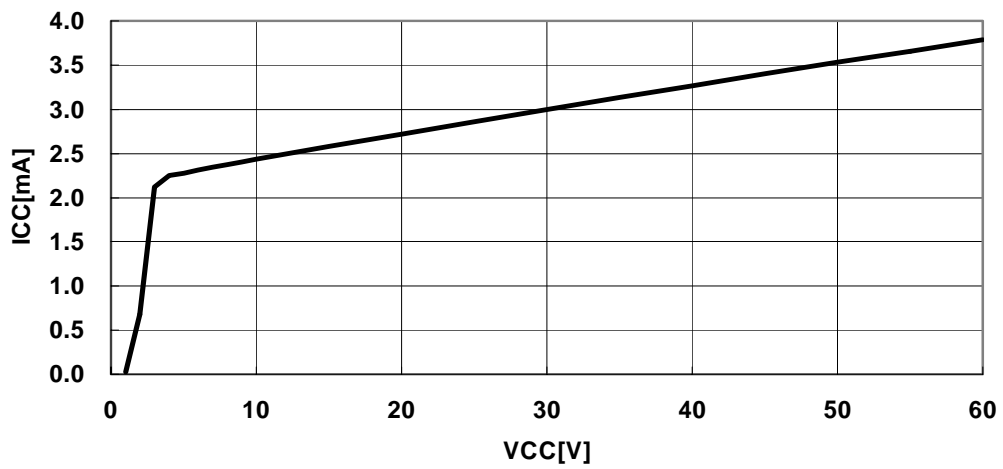

### Lock Alarm Output Voltage VS. Lock Alarm Output Current

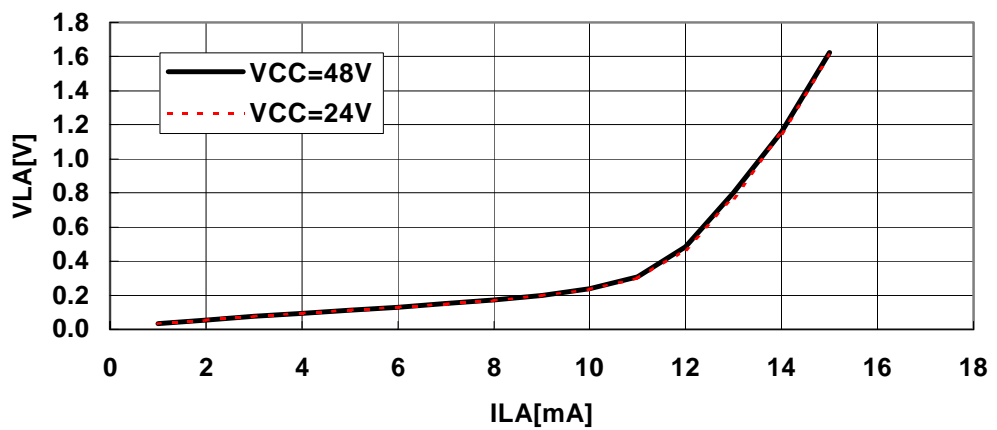

### Output Voltage VS. Output Current

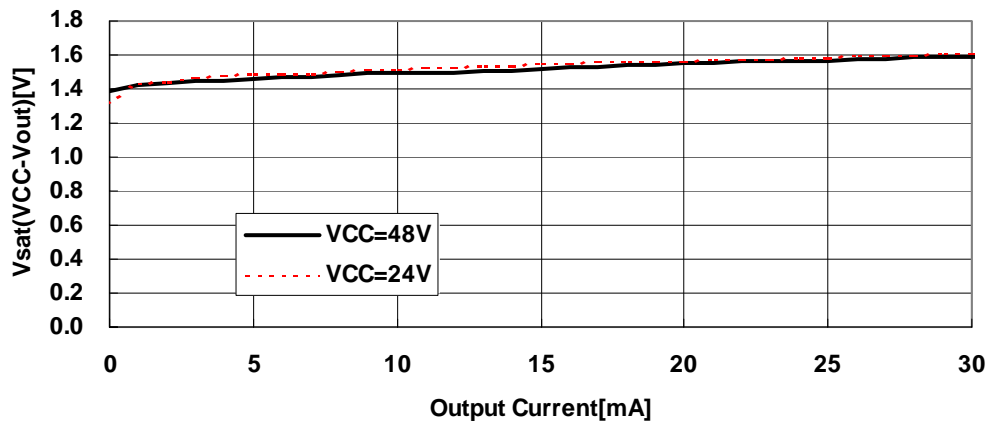

# NJM2640

## ◆ NJM2640 application note

The NJM2640 is a two-phase motor unipolar pre-driver IC featuring 60V operating high voltage process technology.

It is suitable for fan motor drivers for communication equipment where 48V operation is required.

[Application Circuit Example]

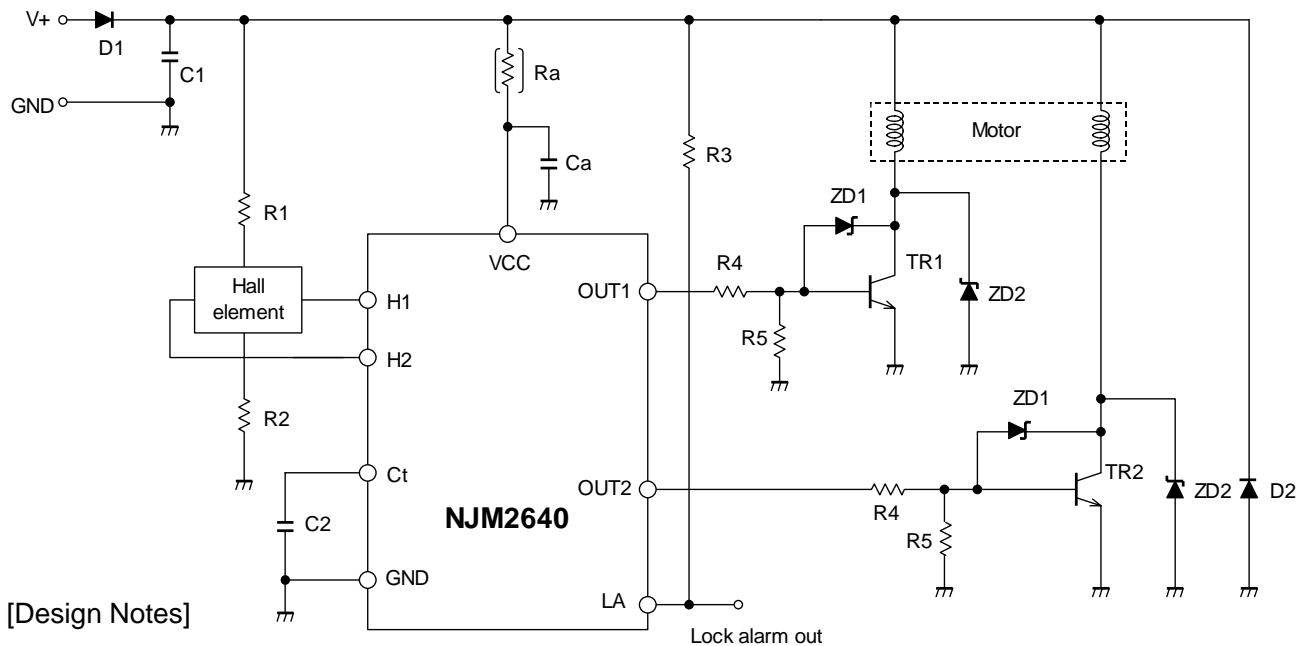

[Design Notes]

Above application example is designed for 48V operation with motor current of 300mA. It uses the following components:

Hall Elements: HW101A (AKD)  
TR1, TR2: 2SD0968A (NEC)

### 1. Selection of C1 and D1:

C1 is used for a noise reduction purpose. A typical value is 0.1 $\mu$ F.

Optimize the value in actual operating conditions if necessary. D1 is a diode for protection against reverse voltage supply. Silicon rectifier diode (WO3C, 10D1 and equivalent) is appropriate.

### 2. Lock Protection Function (Design of C2 value):

Lock Protection Function, consists of Motor Lock Detection and Auto Resume Function, is a safety feature to protect a motor and a driver circuit from fatal destruction in case of motor halt.

Motor Lock Detection detects motor halt due to irregular load conditions and then cuts motor driving current for safety operation. When Lock Detection is activated; Lock Alert Out (LA: Pin 3) goes to L.

A value of C2 determines Lock detection time ( $T_{on}$ ) and Auto Resume Time ( $T_{off}$ ).

Lock detection time ( $T_{on}$ ) is given by:

$$T_{ON} = C2 \frac{V_{ch} - V_{cl}}{I_c} [\text{sec}]$$

Where C2 is 0.47uF:

$$T_{ON} = 0.47 \times 10^{-6} \times \frac{2.5 - 0.7}{3.8 \times 10^{-6}} = 0.22 [\text{sec}]$$

Auto Resume Time ( $T_{off}$ ) is given by:

$$T_{OFF} = C2 \frac{V_{ch} - V_{cl}}{I_{dc}} [\text{sec}]$$

Where C2 is 0.47uF:

$$T_{OFF} = 0.47 \times 10^{-6} \times \frac{2.5 - 0.7}{0.75 \times 10^{-6}} = 1.13 [\text{sec}]$$

In actual application, Lock detection time ( $T_{on}$ ) is affected by the mechanical time constant of a motor. Therefore, constant start up must be confirmed in actual evaluation taking operating variations (i.e. Temperature, Voltage change and so on) in consideration.

A typical value of C2 is either 0.47uF or 1uF depending on a motor.

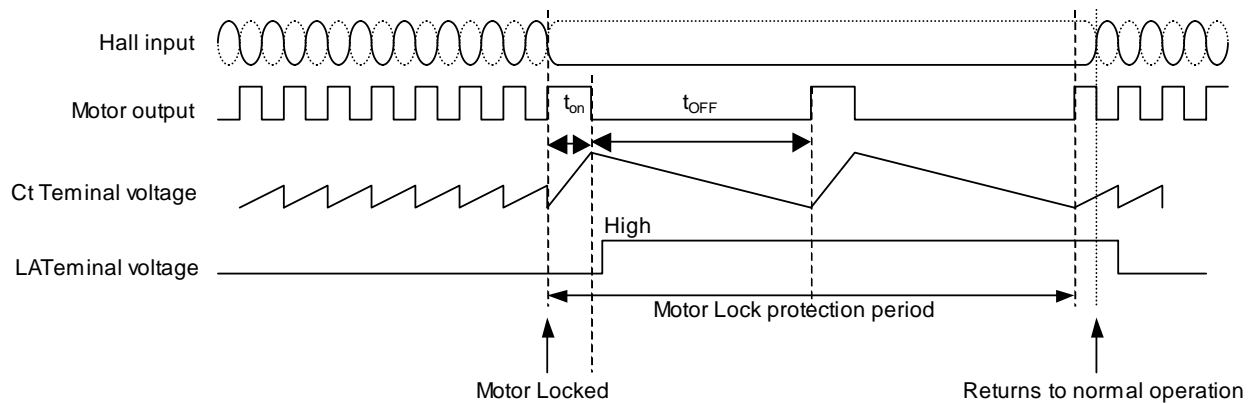

### Lock Protection

Lock Alert Out (LA: Pin 3) is an open collector output and R3 is a pull up resistor. A typical value of R3 is 10kΩ.

It must be noted that Lock Alert Out stays a H state during few hundred milliseconds from power up as shown in the picture below.

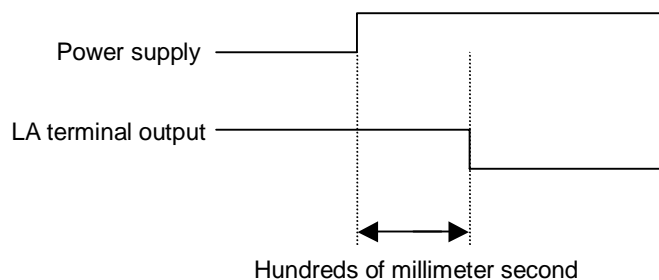

# NJM2640

### 3. Design of hall element bias resistance (R1 and R2)

Hall amplifier is a differential amplifier with hysteresis characteristics (24mV typical).

The common-mode input voltage is between 1.5V and  $V_{cc}-2V$  and the input signal must be within the range.

Non-excitation hall bias voltage is to be set at a half of VCC for effective use of common-mode input voltage range. Therefore the same value of hall bias resistors is selected for R1 and R2.

Given that the bias current is set to be 5mA by HW101A datasheet, R1 and R2 can be determined as follows:

$$R1 + R2 = \frac{V_{cc}}{I_{hbias}} = \frac{48}{5 \times 10^{-3}} = 9.6k\Omega$$
$$R1 = R2 = 4.8k\Omega$$

The output voltage of hall elements is influenced by the bias current and magnetic flux density of hall elements.

The optimum input voltage of NJM2640 is 100mVp-p and higher. With such input voltage, the highest efficiency can be obtained.

### 4. Design of Power Transistor base resistance (R4 and R5)

HFE of 2SD0968A (NEC) is 50 from its datasheet. Given that  $I_o$  is 300mA, the base current of TR1 is 6mA.

R4 is given by:

$$R4 = \frac{V_{CC} - V_{BE} - V_{CE}}{I_B}$$
$$R4 = \frac{48 - 0.7 - 1.5}{6 \times 10^{-3}} = 7.63 \times 10^3 = 7.6k\Omega$$

Where; VCC is 48V, VCE of NJM2640 is 1.5V, VBE of TR1 is 0.7V

The pull down resistance R5 (connected to TR1) influences turn-off time of TR1.

Faster Turn-off time of TR1 reduces peak current of motor winding current resulting in lower echo fan noise (often called as Echo noise) during operation.

A typical R5 value is ranging from 1kΩ to 10kΩ. As explained the above, it is highly recommended to determine the value with actual application for better noise performance.

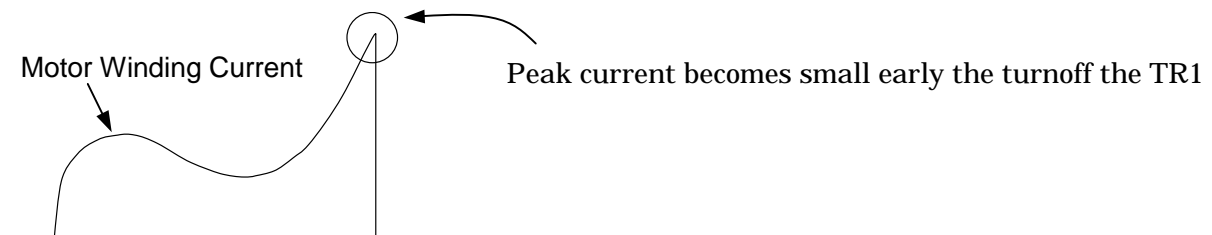

### 5. Design of spike killer for power transistor (ZD1 and ZD2)

Zenner diodes (often referred as spike killer ) are used for limiting kick back voltage of motor winding generated when power transistors is (TR1 and TR2) turned off from on.

There are two methodologies to consume kick back voltage:

- 1) **By insertion of ZD1** (zenner diode connected between Base and Emitter of TR1)  
Energy of kick back voltage is consumed by TR1(or TR2). When ZD1 is in operation, Collector voltage is sum of  $V_{be}$  and ZD1. Therefore, breakdown voltage of ZD1 must be lower than that of TR1.
- 2) **By insertion of ZD2** (zenner diode connected between Collector and Emitter of TR1)  
Energy of kick back voltage is consumed by ZD2. To protect TR1, breakdown voltage of ZD2 must be lower than that of TR1.  
This method is generally used when Energy of kick back voltage is large. In such application, power rating of ZD must take in consideration.

## 6. VCC input (Design of **Ra** and **Ca**)

Ra and Ca must be used if VCC exceeds operating voltage range of NJM2640.

Example) VCC 60V Application

Given that current consumption of NJM2640 is 4mA (at VCC=48V), Ra is given by:

$$Ra = \frac{60 - 48}{4 \times 10^{-3}} = 3k\Omega$$

Ca is used if NJM2640 is oscillated or shows unstable operation. A typical value Ca is from 0.01 $\mu$ F to 0.1 $\mu$ F. A ceramic type is recommended and it must be place near VCC and Gnd.

Inserting Ra and Ca also improves ESD immunity.

## 7. Protection from active power on and off (**D2**)

If an application requires active power on and off, TR1 (TR2) may be damaged or resulted in destruction.

In such application, adding diode between motor winding and Gnd will reduce the damage.

The specifications on this data book are only given for information, without any guarantee as regards either mistakes or omissions. The application circuit in this data book are described only to show representative usages of the product and not intended for the guarantee or permission of any right including the industrial rights.