

P4C168, P4C169, P4C170 ULTRA HIGH SPEED 4K x 4 STATIC CMOS RAMS

FEATURES

- Full CMOS, 6T Cell
- High Speed (Equal Access and Cycle Times)
 - 12/15/20/25/35ns (Commercial)
 - 20/25/35/45/55/70ns (P4C168 Military)
- Low Power Operation (Commercial)
 - 715 mW Active
 - 193 mW Standby (TTL Input) P4C168
 - 83 mW Standby (CMOS Input) P4C168
- Single 5V±10% Power Supply
- Fully TTL Compatible, Common I/O Ports
- Three Options
 - P4C168 Low Power Standby Mode
 - P4C169 Fast Chip Select Control
 - P4C170 Fast Chip Select, Output Enable Controls
- Standard Pinout (JEDEC Approved)
 - P4C168: 20-pin DIP, SOJ, LCC, SOIC, CERPACK, and Flat Pack
 - P4C169: 20-pin DIP and SOIC
 - P4C170: 22-pin DIP

DESCRIPTION

The P4C168, P4C169 and P4C170 are a family of 16,384-bit ultra high-speed static RAMs organized as 4K x 4. All three devices have common input/output ports. The P4C168 enters the standby mode when the chip enable (\overline{CE}) control goes HIGH; with CMOS input levels, power consumption is only 83mW in this mode. Both the P4C169 and the P4C170 offer a fast chip select access time that is only 67% of the address access time. In addition, the P4C170 includes an output enable (\overline{OE}) control to eliminate data bus contention. The RAMs operate from a single 5V ± 10% tolerance power supply.

Access times as fast as 12 nanoseconds are available, permitting greatly enhanced system operating speeds. CMOS is used to reduce power consumption to a low 715 mW active, 193 mW standby.

The P4C168 and P4C169 are available in 20-pin (P4C170 in 22-pin) 300 mil DIP packages providing excellent board level densities. The P4C168 is also available in 20-pin 300 mil SOIC, SOJ, CERPACK, and Flat Pack packages.

The P4C169 is also available in a 20-pin 300 mil SOIC package.

FUNCTIONAL BLOCK DIAGRAM

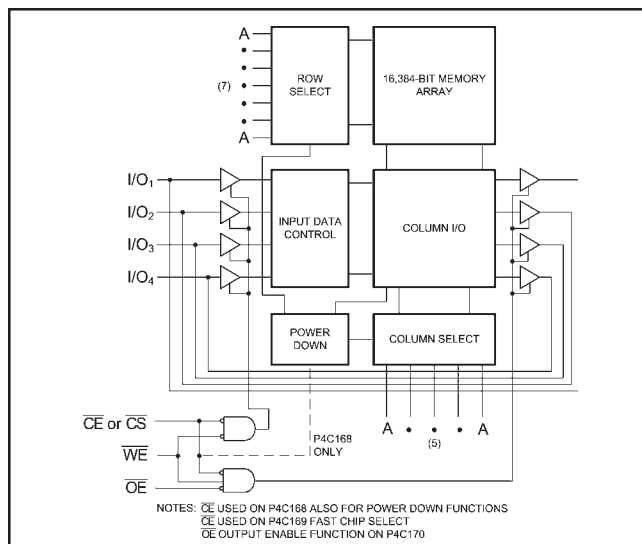

PIN CONFIGURATIONS

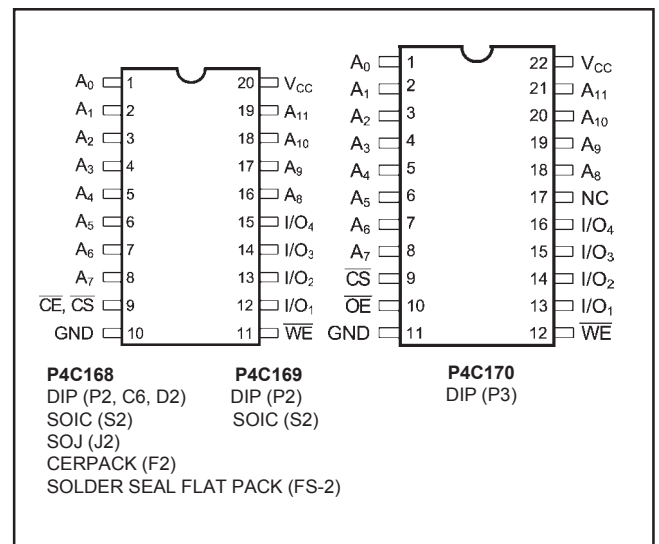

MAXIMUM RATINGS⁽¹⁾

Symbol	Parameter	Value	Unit
V_{CC}	Power Supply Pin with Respect to GND	-0.5 to +7	V
V_{TERM}	Terminal Voltage with Respect to GND (up to 7.0V)	-0.5 to $V_{CC} + 0.5$	V
T_A	Operating Temperature	-55 to +125	°C

Symbol	Parameter	Value	Unit
T_{BIAS}	Temperature Under Bias	-55 to +125	°C
T_{STG}	Storage Temperature	-65 to +150	°C
P_T	Power Dissipation	1.0	W
I_{OUT}	DC Output Current	50	mA

RECOMMENDED OPERATING CONDITIONS

Grade ⁽²⁾	Ambient Temp	Gnd	V_{CC}
Commercial	0°C to 70°C	0V	5.0V ± 10%
Military	-55°C to +125°C	0V	5.0V ± 10%

CAPACITANCES⁽⁴⁾

($V_{CC} = 5.0V$, $T_A = 25°C$, $f = 1.0MHz$)

Symbol	Parameter	Conditions	Typ.	Unit
C_{IN}	Input Capacitance	$V_{IN} = 0V$	5	pF
C_{OUT}	Output Capacitance	$V_{OUT} = 0V$	7	pF

DC ELECTRICAL CHARACTERISTICS

Symbol	Parameter	Test Conditions	P4C168/169/170		Unit
			Min	Max	
V_{IH}	Input High Voltage		2.2	$V_{CC} + 0.5$	V
V_{IL}	Input Low Voltage		-0.5(3)	0.8	V
V_{HC}	CMOS Input High Voltage		$V_{CC} - 0.2$	$V_{CC} + 0.5$	V
V_{LC}	CMOS Input Low Voltage		-0.5(3)	0.2	V
V_{CD}	Input Clamp Diode Voltage	$V_{CC} = \text{Min.}, I_{IN} = -18 \text{ mA}$		-1.2	V
V_{OL}	Output Low Voltage (TTL Load)	$I_{OL} = +8 \text{ mA}, V_{CC} = \text{Min.}$		0.4	V
V_{OLC}	Output Low Voltage (CMOS Load)	$I_{OLC} = +100 \mu\text{A}, V_{CC} = \text{Min.}$		0.2	V
V_{OH}	Output High Voltage (TTL Load)	$I_{OH} = -4 \text{ mA}, V_{CC} = \text{Min.}$	2.4		V
V_{OHC}	Output High Voltage (CMOS Load)	$I_{OHC} = -100 \mu\text{A}, V_{CC} = \text{Min.}$	$V_{CC} - 0.2$		V
I_{LI}	Input Leakage Current	$V_{CC} = \text{Max.}, V_{IN} = \text{GND to } V_{CC}$	Mil. Comm'l -10 -5	+10 +5	μA
I_{LO}	Output Leakage Current	$V_{CC} = \text{Max.}, \overline{CS} = V_{IH}, V_{OUT} = \text{GND to } V_{CC}$	Mil. Comm'l -10 -5	+10 +5	μA
I_{CC}	Dynamic Operating Current	$V_{CC} = \text{Max.}, f = \text{Max.}, \text{Outputs Open}$	—	130	mA
I_{SB}	Standby Power Supply Current (TTL Input Levels) P4C168 only	$\overline{CE} \geq V_{IH}, V_{CC} = \text{Max.}, f = \text{Max.}, \text{Outputs Open}$	—	35	mA
I_{SB1}	Standby Power Supply Current (CMOS Input Levels) P4C168 only	$\overline{CE} \geq V_{HC}, V_{CC} = \text{Max.}, f = 0, V_{IN} \leq V_{LC} \text{ or } V_{IN} \geq V_{HC}$	—	15	mA

AC CHARACTERISTICS—READ CYCLE $(V_{CC} = 5V \pm 10\%$, All Temperature Ranges)⁽²⁾

Sym	Parameter	-12		-15		-20		-25		-35		Unit
		Min	Max	Min	Max	Min	Max	Min	Max	Min	Max	
t_{RC}	Read Cycle Time	12		15		20		25		35		ns
t_{AA}	Address Access Time		12		15		20		25		35	ns
t_{AC}^{\S}	Chip Enable Access Time		12		15		20		25		35	ns
t_{AC}^{\ddagger}	Chip Select Access Time		8		9		12		15		20	ns
t_{OH}	Output Hold from Address Change	2		2		2		2		2		ns
t_{LZ}^{\ddagger}	Chip Enable to Output in Low Z	2		2		2		2		2		ns
t_{HZ}^{\dagger}	Chip Disable to Output in High Z		7		8		9		10		15	ns
t_{OE}^{\dagger}	Output Enable to Data Valid		8		10		12		15		15	ns
t_{OLZ}^{\dagger}	Output Enable to Output in Low Z	0		0		0		0		0		ns
t_{OHZ}^{\dagger}	Output Disable to Output in High Z		6		7		9		11		15	ns
t_{RCS}	Read Command Setup Time	0		0		0		0		0		ns
t_{RCH}	Read Command Hold Time	0		0		0		0		0		ns
t_{PU}^{\S}	Chip Enable to Power Up Time	0		0		0		0		0		ns
t_{PD}^{\S}	Chip Disable to Power Down Time		12		15		20		25		35	ns

AC CHARACTERISTICS—READ CYCLE (CONTINUED) $(V_{CC} = 5V \pm 10\%$, All Temperature Ranges)⁽²⁾

Sym	Parameter	-45		-55		-70		Unit
		Min	Max	Min	Max	Min	Max	
t_{RC}	Read Cycle Time	45		55		70		ns
t_{AA}	Address Access Time		45		55		70	ns
t_{AC}^{\S}	Chip Enable Access Time		45		55		70	ns
t_{OH}	Output Hold from Address Change	2		2		2		ns
t_{LZ}^{\ddagger}	Chip Enable to Output in Low Z	2		2		2		ns
t_{HZ}^{\dagger}	Chip Disable to Output in High Z		25		25		30	ns
t_{RCS}	Read Command Setup Time	0		0		0		ns
t_{RCH}	Read Command Hold Time	0		0		0		ns
t_{PU}^{\S}	Chip Enable to Power Up Time	0		0		0		ns
t_{PD}^{\S}	Chip Disable to Power Down Time		45		55		70	ns

§ P4C168 only

† P4C170 only

‡ Chip Select/Deselect for P4C169 and P4C170

AC ELECTRICAL CHARACTERISTICS - WRITE CYCLE $(V_{CC} = 5V \pm 10\%$, All Temperature Ranges)⁽²⁾

Sym	Parameter	-12		-15		-20		-25		-35		Unit
		Min	Max	Min	Max	Min	Max	Min	Max	Min	Max	
t _{WC}	Write Cycle Time	12		15		18		20		30		ns
t _{cw}	Chip Enable Time to End of Write	12		15		18		20		30		ns
t _{AW}	Address Valid to End of Write	12		15		18		20		30		ns
t _{AS}	Address Set-up Time	0		0		0		0		0		ns
t _{WP}	Write Pulse Width	12		15		18		20		30		ns
t _{AH}	Address Hold Time	0		0		0		0		0		ns
t _{DW}	Data Valid to End of Write	7		8		10		10		15		ns
t _{DH}	Data Hold Time	0		0		0		0		0		ns
t _{WZ}	Write Enable to Output in High Z		4		5		6		7		13	ns
t _{OW}	Output Active from End of Write	0		0		0		0		0		ns

AC ELECTRICAL CHARACTERISTICS - WRITE CYCLE (CONTINUED) $(V_{CC} = 5V \pm 10\%$, All Temperature Ranges)⁽²⁾

Sym	Parameter	-45		-55		-70		Unit
		Min	Max	Min	Max	Min	Max	
t _{WC}	Write Cycle Time	45		55		70		ns
t _{cw}	Chip Enable Time to End of Write	40		50		60		ns
t _{AW}	Address Valid to End of Write	40		50		60		ns
t _{AS}	Address Set-up Time	0		0		0		ns
t _{WP}	Write Pulse Width	40		50		60		ns
t _{AH}	Address Hold Time	0		0		0		ns
t _{DW}	Data Valid to End of Write	20		20		25		ns
t _{DH}	Data Hold Time	3		3		3		ns
t _{WZ}	Write Enable to Output in High Z		20		25		30	ns
t _{OW}	Output Active from End of Write	0		0		0		ns

TIMING WAVEFORM OF WRITE CYCLE NO. 1 (\overline{WE} CONTROLLED)⁽¹⁰⁾

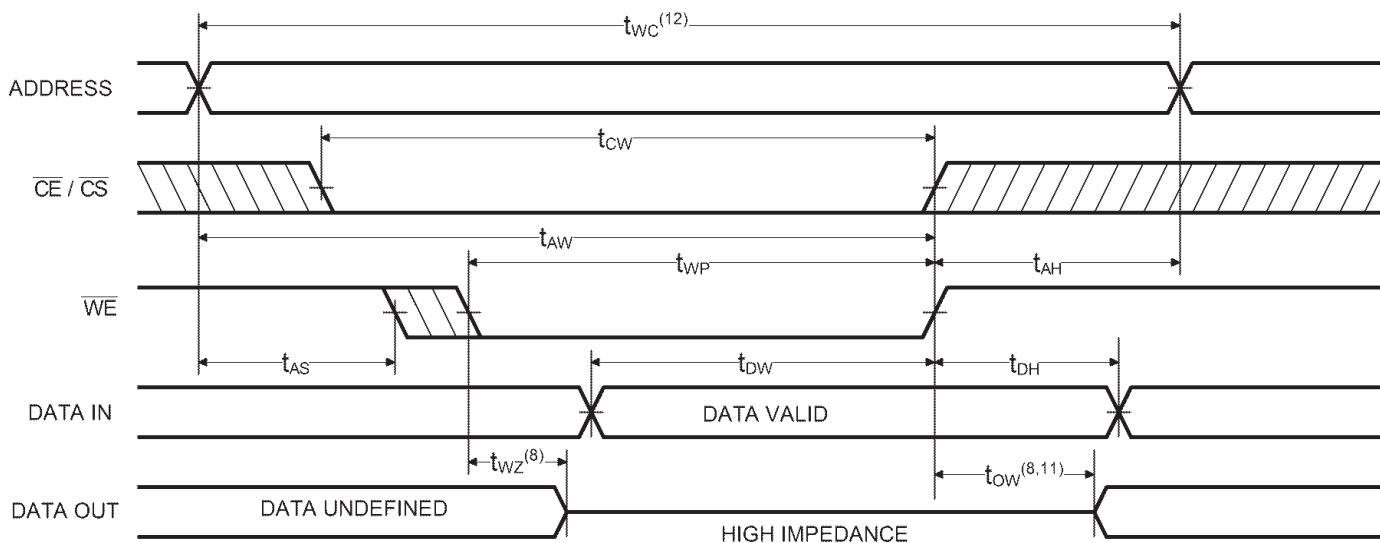

Notes:

- 10. $\overline{CE}/\overline{CS}$ and \overline{WE} must be LOW for WRITE cycle.
- 11. If $\overline{CE}/\overline{CS}$ goes HIGH simultaneously with \overline{WE} HIGH, the output remains in a high impedance state.

- 12. Write Cycle Time is measured from the last valid address to the first transitioning address.

TIMING WAVEFORM OF WRITE CYCLE NO. 2 ($\overline{CE}/\overline{CS}$ CONTROLLED)⁽¹⁰⁾

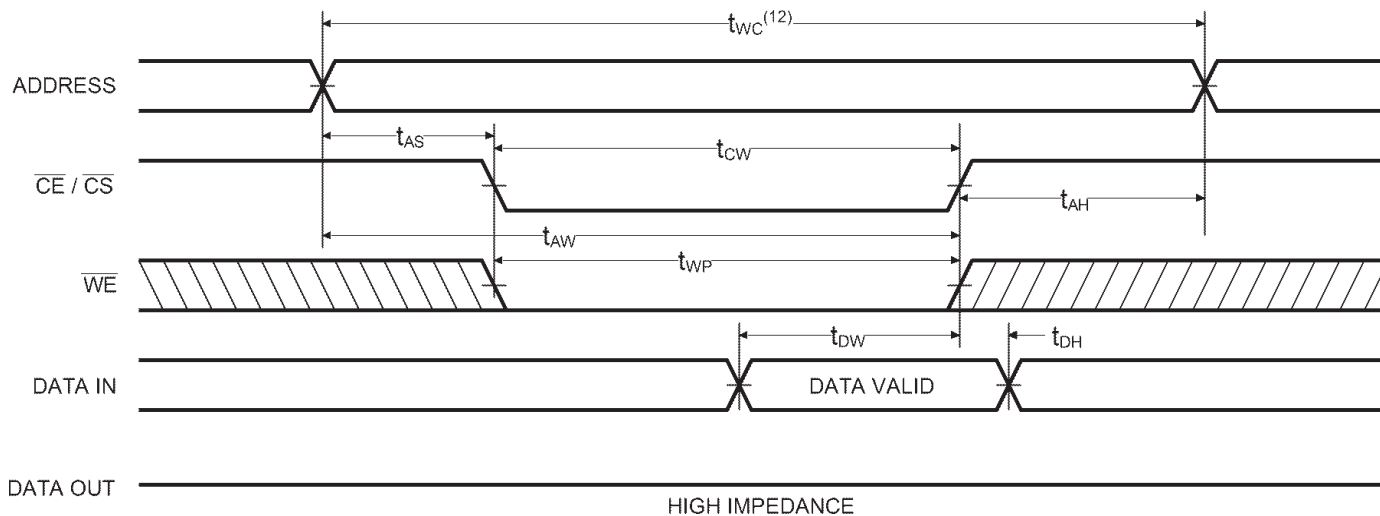

TRUTH TABLES

P4C168 (P4C169)

Mode	\overline{CE} (\overline{CS})	\overline{WE}	Output
Standby (Deselect)	H	X	High Z
Read	L	H	D _{OUT}
Write	L	L	High Z

P4C170

Mode	\overline{CE}	\overline{WE}	\overline{OE}	Output
Deselect	H	X	X	High Z
Read	L	H	L	D _{OUT}
Output Inhibit	L	H	H	High Z
Write	L	L	X	High Z

AC TEST CONDITIONS

Input Pulse Levels	GND to 3.0V
Input Rise and Fall Times	3ns
Input Timing Reference Level	1.5V
Output Timing Reference Level	1.5V
Output Load	See Figures 1 and 2

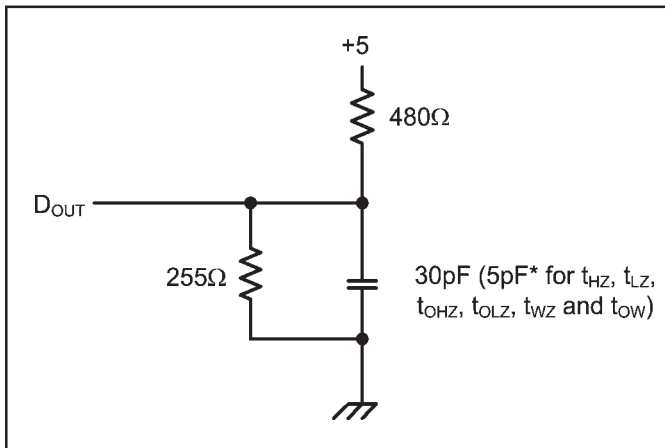

Figure 1. Output Load

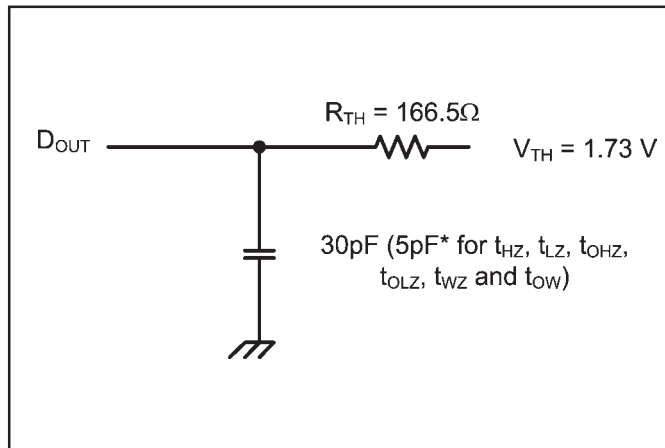

Figure 2. Thevenin Equivalent

* including scope and test fixture.

Note:

Because of the ultra-high speed of the P4C168, P4C169 AND P4C170 care must be taken when testing these devices; an inadequate setup can cause a normal functioning part to be rejected as faulty. Long high-inductance leads that cause supply bounce must be avoided by bringing the V_{CC} and ground planes directly up to the contactor fingers. A high frequency capacitor of 0.01 μF is also required between V_{CC} and ground.

To avoid signal reflections, proper termination must be used; for example, a 50Ω test environment should be terminated into a 50Ω load with 1.73V (Thevenin Voltage) at the comparator input, and a 116Ω resistor must be used in series with D_{OUT} to match 166Ω (Thevenin Resistance).

LCC PIN CONFIGURATION

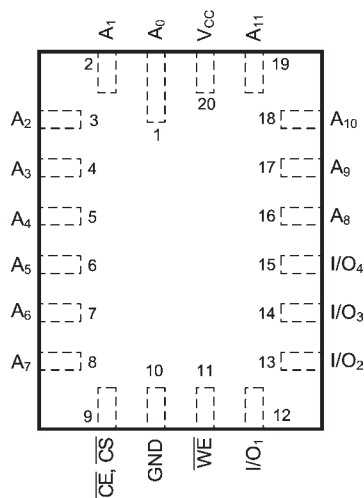

LCC (L9)

ORDERING INFORMATION

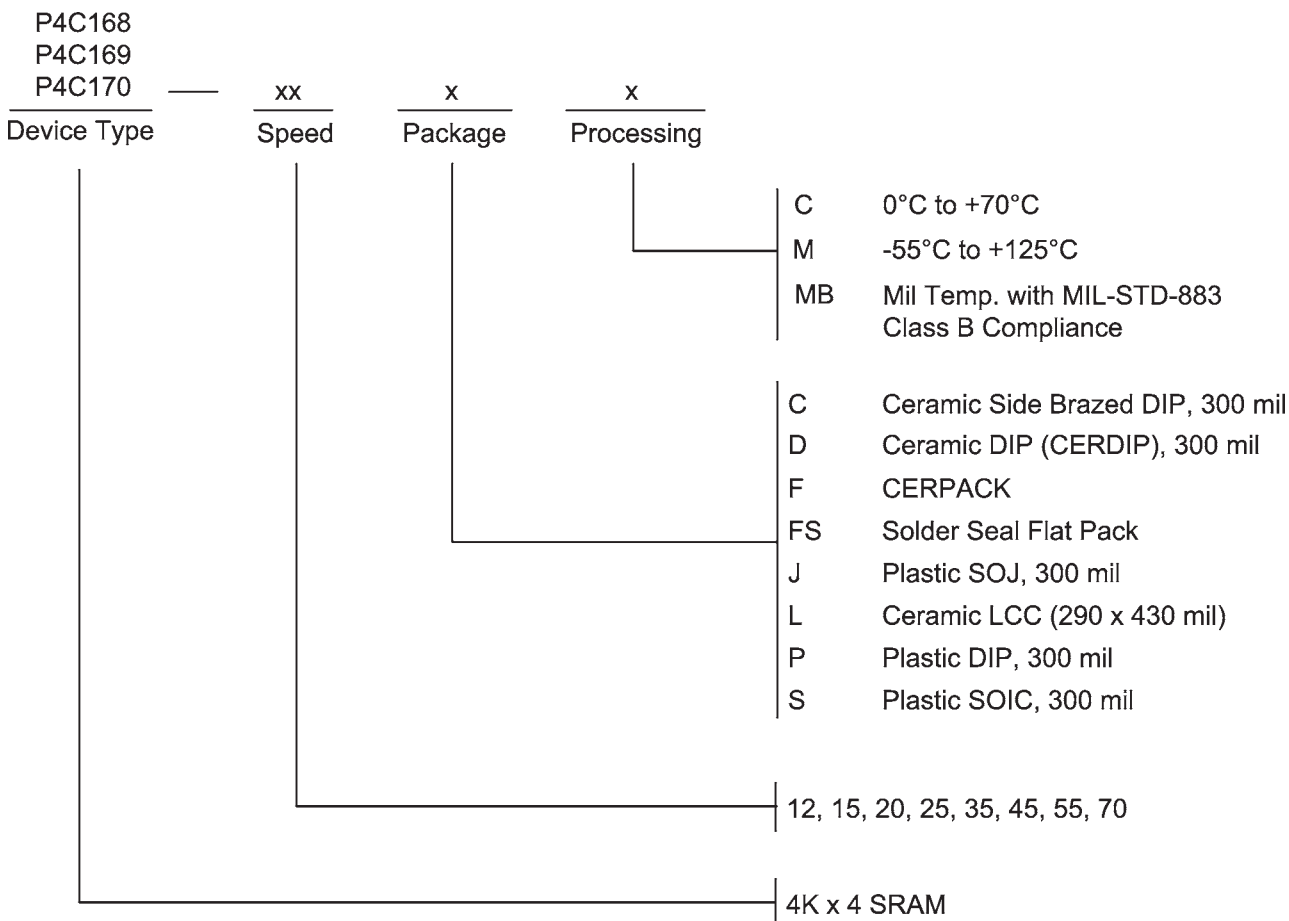

SELECTION GUIDE

The P4C168, P4C169 and P4C170 are available in the following temperature, speed and package options.

Temperature Range	Package	Speed				
		12	15	20	25	35
Commercial Temperature	Plastic DIP	-12PC	-15PC	-20PC	-25PC	N/A
	Plastic SOIC†	-12SC	-15SC	-20SC	-25SC	N/A
	Plastic SOJ††	-12JC	-15JC	-20JC	-25JC	N/A
Military Temperature (P4C168 only)	LCC	N/A	-15LM	-20LM	-25LM	-35LM
	CERDIP	N/A	-15DM	-20DM	-25DM	-35DM
	Side Brazed DIP	N/A	-15CM	-20CM	-25CM	-35CM
	CERPACK	N/A	-15FM	-20FM	-25FM	-35FM
	Solder Seal Flat Pack	N/A	-15FSM	-20FSM	-25FSM	-35FSM
Military Processed* (P4C168 only)	LCC	N/A	-15LMB	-20LMB	-25LMB	-35LMB
	CERDIP	N/A	-15DMB	-20DMB	-25DMB	-35DMB
	Side Brazed DIP	N/A	-15CMB	-20CMB	-25CMB	-35CMB
	CERPACK	N/A	-15FMB	-20FMB	-25FMB	-35FMB
	Solder Seal Flat Pack	N/A	-15FSMB	-20FSMB	-25FSMB	-35FSMB

† P4C168 and P4C169 only.

†† P4C168

* Military temperature range with MIL-STD-883, Class B processing.

N/A = Not available

SELECTION GUIDE (CONTINUED)

Temperature Range	Package	Speed		
		45	55	70
Military Temperature (P4C168 only)	LCC	-45LM	-55LM	-70LM
	CERDIP	-45DM	-55DM	-70DM
	Side Brazed DIP	-45CM	-55CM	-70CM
	CERPACK	-45FM	-55FM	-70FM
	Solder Seal Flat Pack	-45FSM	-55FSM	-70FSM
Military Processed* (P4C168 only)	LCC	-45LMB	-55LMB	-70LMB
	CERDIP	-45DMB	-55DMB	-70DMB
	Side Brazed DIP	-45CMB	-55CMB	-70CMB
	CERPACK	-45FMB	-55FMB	-70FMB
	Solder Seal Flat Pack	-55FSMB	-55FSMB	-70FSMB

* Military temperature range with MIL-STD-883, Class B processing.

Pkg #	C6	
# Pins	20 (300 mil)	
Symbol	Min	Max
A	-	0.200
b	0.014	0.026
b2	0.045	0.065
C	0.008	0.018
D	-	1.060
E	0.220	0.310
eA	0.300 BSC	
e	0.100 BSC	
L	0.125	0.200
Q	0.015	0.070
S1	0.005	-
S2	0.005	-

SIDE BRAZED DUAL IN-LINE PACKAGE

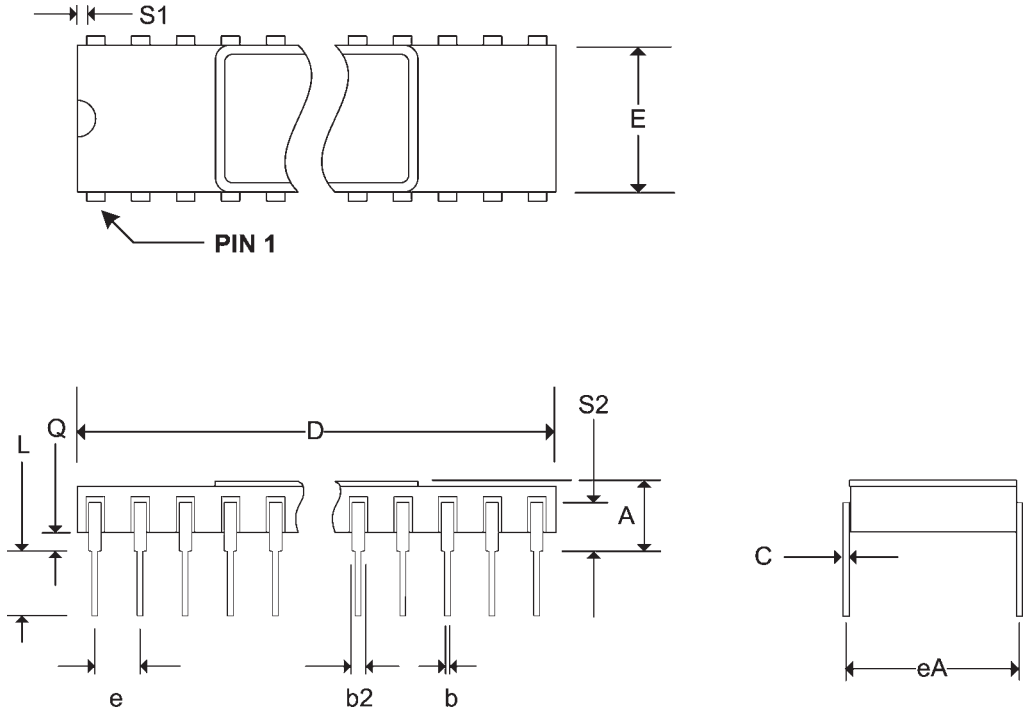

Pkg #	F2	
# Pins	20	
Symbol	Min	Max
A	0.060	0.090
b	0.015	0.022
c	0.004	0.009
D	-	0.530
E	0.305	0.355
e	0.050 BSC	
k	0.005	0.018
L	0.250	0.370
Q	0.026	0.045
S	-	0.085
S1	0.005	-

CERPACK CERAMIC FLAT PACKAGE

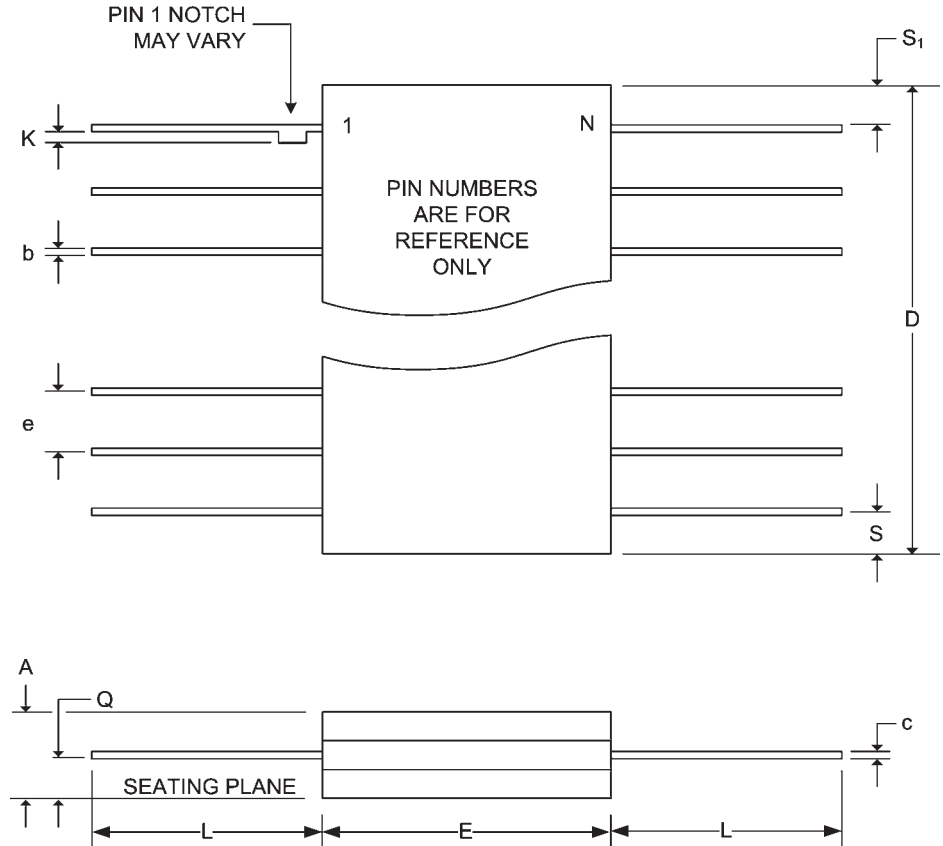

Pkg #	FS-2	
# Pins	20	
Symbol	Min	Max
A	0.045	0.115
b	0.015	0.022
b1	0.015	0.019
c	0.004	0.009
c1	0.004	0.006
D	-	0.540
E	0.245	0.300
E1	-	0.330
E2	0.130	-
E3	0.030	-
e	0.050 BSC	
k	0.008	0.015
L	0.250	0.370
Q	0.026	0.045
S1	0.000	-
M	-	0.0015
N	20	

SOLDER SEAL FLAT PACKAGE

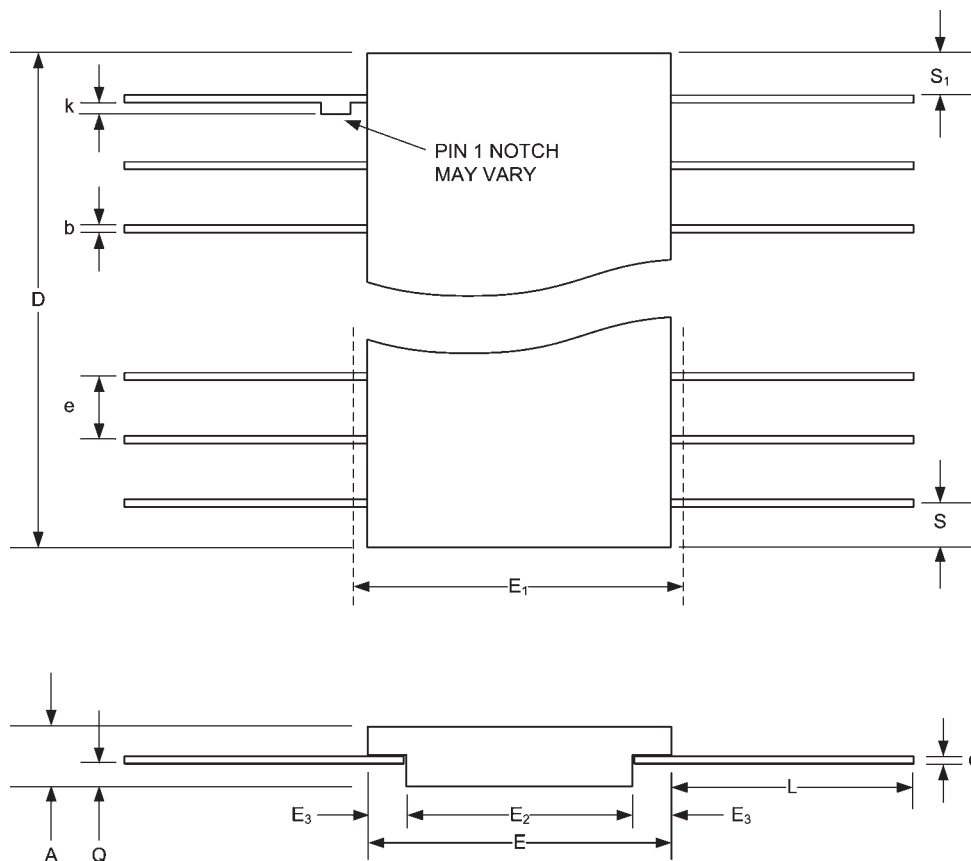

Pkg #	J2	
# Pins	20 (300 mil)	
Symbol	Min	Max
A	0.120	0.140
A1	0.080	-
b	0.014	0.020
C	0.008	0.013
D	0.496	0.512
e	0.050 BSC	
E	0.335	0.347
E1	0.292	0.300
E2	0.267 BSC	
Q	0.025	-

SOJ SMALL OUTLINE IC PACKAGE

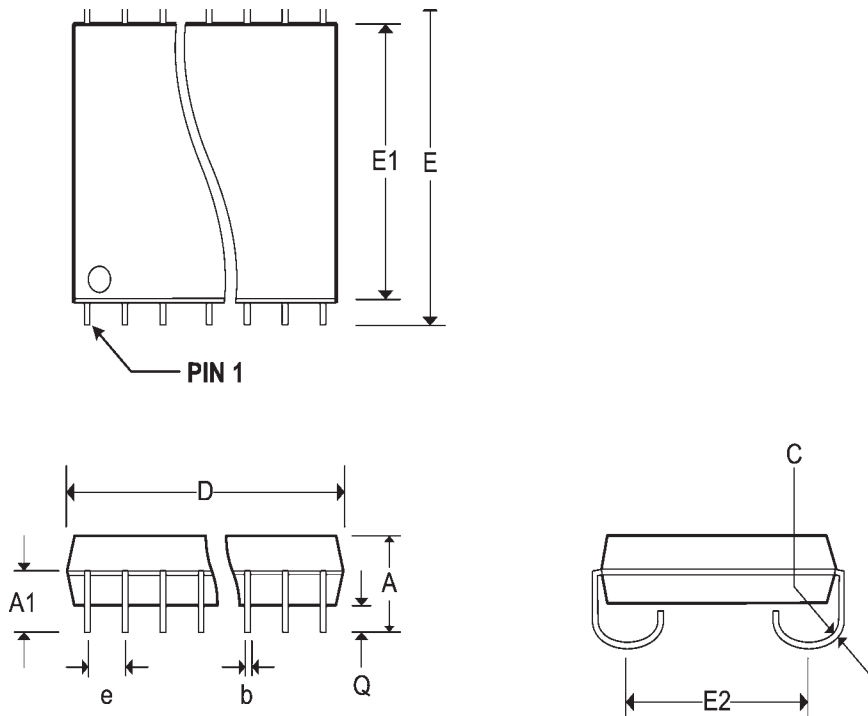

Pkg #	L9	
# Pins	20	
Symbol	Min	Max
A	0.060	0.075
A1	0.050	0.066
B1	0.022	0.028
D	0.280	0.305
D1	0.150 BSC	
D2	0.075 BSC	
D3	-	0.305
E	0.420	0.440
E1	0.250 BSC	
E2	0.125 BSC	
E3	-	0.440
e	0.050 BSC	
h	0.020 REF	
j	0.010 REF	
L	0.045	0.055
L1	0.045	0.055
L2	0.075	0.098
ND	4	
NE	6	

RECTANGULAR LEADLESS CHIP CARRIER

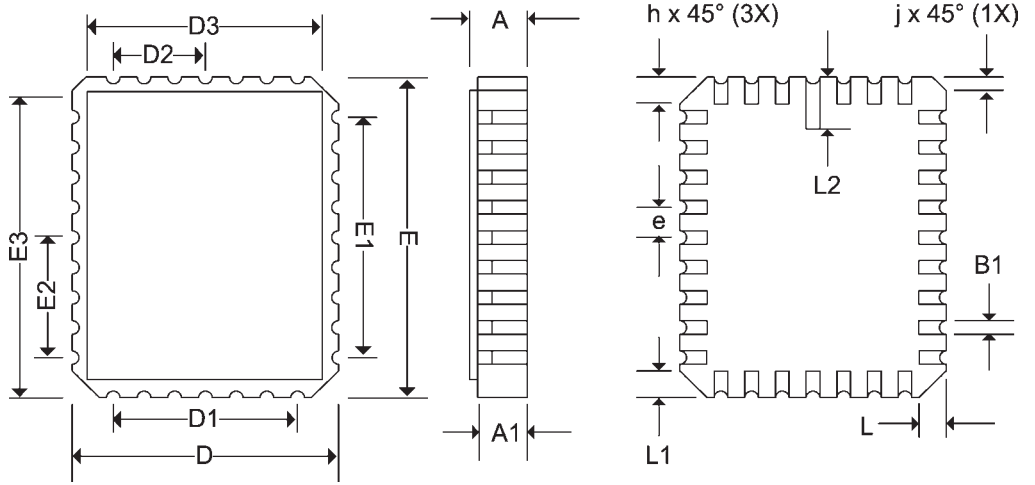

Pkg #	P2	
# Pins	20 (300 mil)	
Symbol	Min	Max
A	-	0.210
A1	0.015	-
b	0.014	0.022
b2	0.045	0.070
C	0.008	0.014
D	0.980	1.060
E1	0.240	0.280
E	0.300	0.325
e	0.100 BSC	
eB	-	0.430
L	0.115	0.150
α	0°	15°

PLASTIC DUAL IN-LINE PACKAGE (P4C168, P4C169)

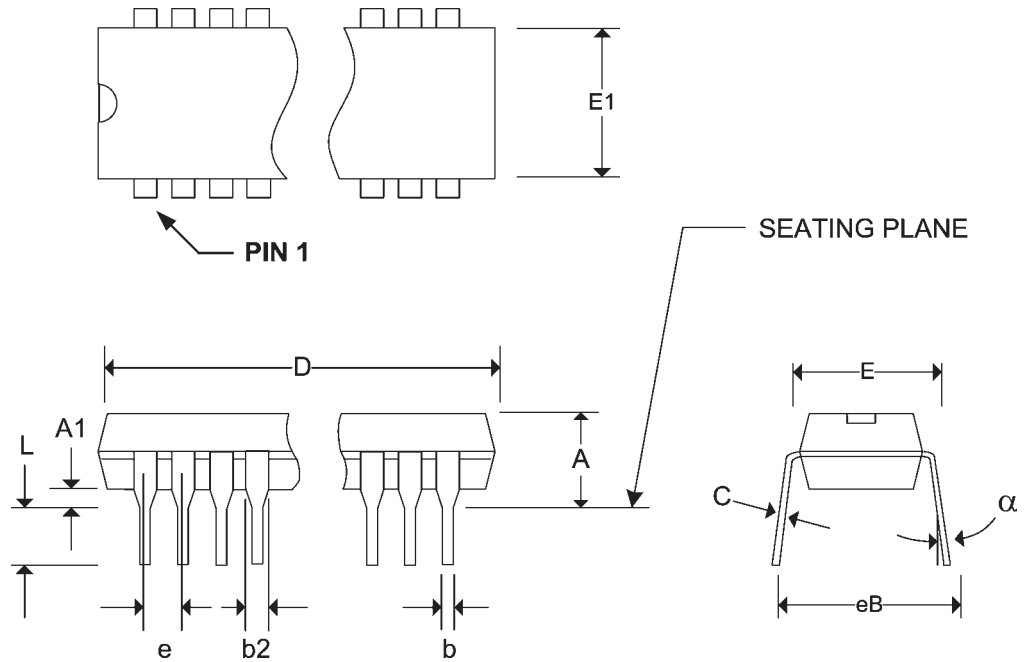

Pkg #	P3	
# Pins	22 (300 Mil)	
Symbol	Min	Max
A	-	0.210
A1	0.015	-
b	0.014	0.022
b2	0.045	0.070
C	0.008	0.014
D	1.145	1.165
E1	0.240	0.280
E	0.300	0.325
e	0.100 BSC	
eB	-	0.430
L	0.115	0.150
α	0°	15°

PLASTIC DUAL IN-LINE PACKAGE (P4C170)

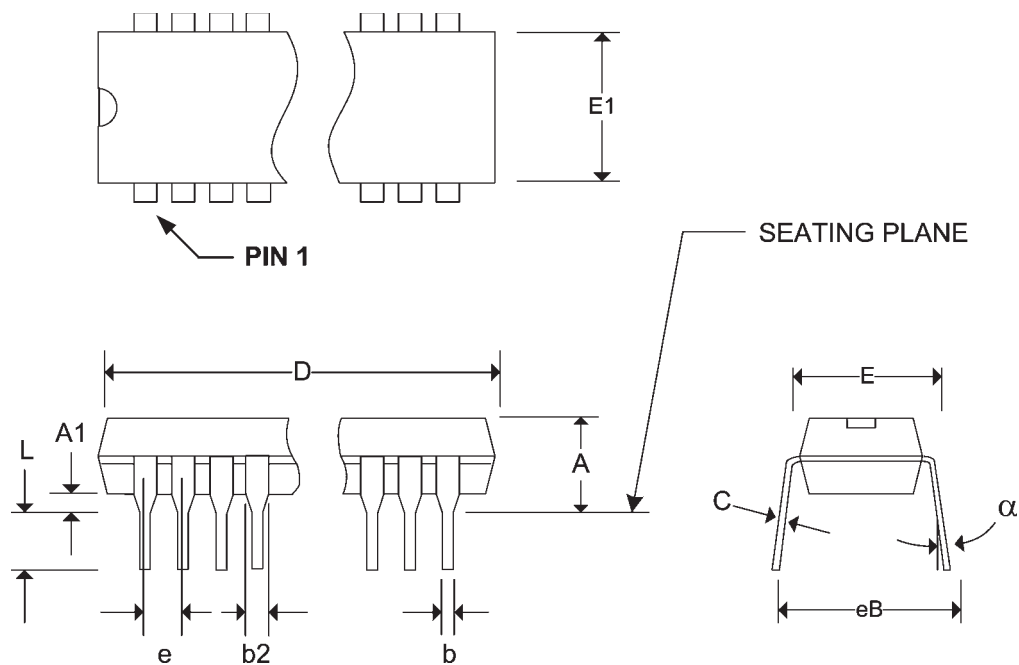

Pkg #	S2	
# Pins	20 (300 mil)	
Symbol	Min	Max
A	0.093	0.104
A1	0.004	0.012
b2	0.013	0.020
C	0.009	0.012
D	0.496	0.511
e	0.050 BSC	
E	0.291	0.299
H	0.394	0.419
h	0.010	0.029
L	0.016	0.050
α	0°	8°

SOIC/SOP SMALL OUTLINE IC PACKAGE

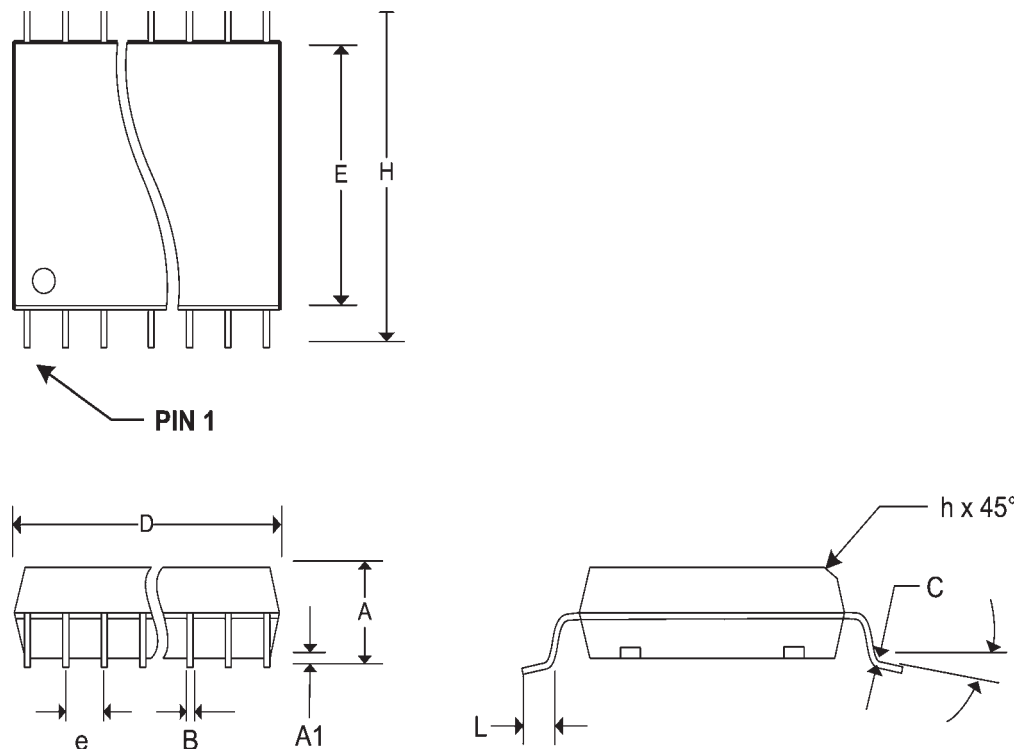

Pkg #	D2	
# Pins	20 (300 mil)	
Symbol	Min	Max
A	-	0.200
b	0.014	0.026
b2	0.045	0.065
C	0.008	0.018
D	-	1.060
E	0.220	0.310
eA	0.300 BSC	
e	0.100 BSC	
L	0.125	0.200
Q	0.015	0.070
S1	0.005	-
α	0°	15°

CERDIP DUAL IN-LINE PACKAGE

