

CTP4549 is a high current inductor with the following data and features:

- **Core type:** 1.06" o.d., Iron Powder, perm 33.
 - **Power rating:** 2.16 watts for temp. rise 50°C.
 - **Typical applications:** Filter Inductors in Switch Mode Power Supplies.
- Four mounting styles are offered:**
- 1 Flying leads (1.00"), for vertical or horizontal mounting.
 - 2 4-pin header, for vertical mounting.
 - 3 Threaded center hole, flying leads (2.00").
 - 4 2-pin header, for vertical mounting.



MECHANICAL

Style 1

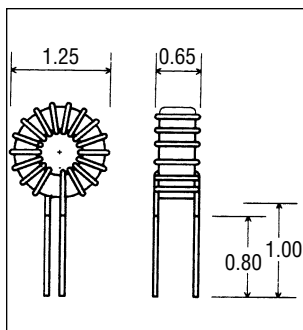

Style 2

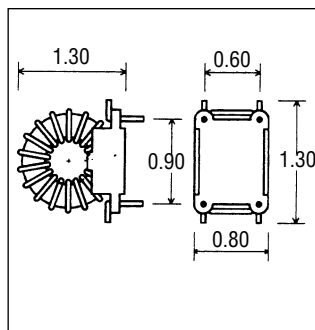

Style 3

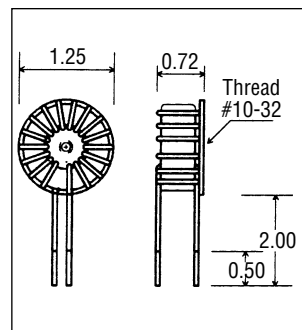

Style 4

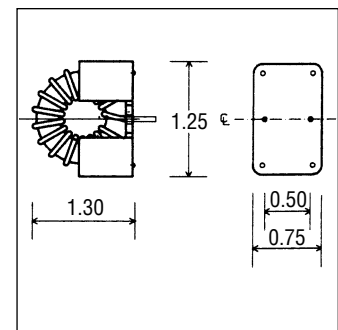

ELECTRICAL SPECIFICATION

Ordering Information: Substitute the style number for the asterisk (*). Example: CTP4549, Style 1, 56uH. Order: CTP4549 - 116

Part No. CTP4549 -	Ind. (uH)	DCR Ohms	Rated Current Amp. RMS	I (amp.) @ Lsat. 10%	I (amp.) @ Lsat. 25%	I (amp.) @ Lsat. 50%	Part No. CTP4549 -	Ind. (uH)	DCR Ohms	Rated Current Amp. RMS	I (amp.) @ Lsat. 10%	I (amp.) @ Lsat. 25%	I (amp.) @ Lsat. 50%
* 01	3.3	0.003	28.8	17.9	44.7	107.2	* 17	68	0.014	12.2	3.9	9.8	23.6
* 02	3.9	0.003	27.7	16.4	41.1	98.6	* 18	82	0.020	10.4	3.6	9.0	21.5
* 03	4.7	0.003	26.4	15.0	37.4	89.8	* 19	100	0.022	9.9	3.2	8.1	19.5
* 04	5.6	0.003	25.3	13.7	34.3	82.3	* 20	120	0.024	9.5	3.0	7.4	17.8
* 05	6.8	0.004	24.2	12.4	31.1	74.7	* 21	150	0.034	8.0	2.6	6.6	15.9
* 06	8.2	0.004	23.1	11.3	28.3	68.0	* 22	180	0.047	6.8	2.4	6.0	14.5
* 07	10	0.004	22.0	10.3	25.7	61.6	* 23	220	0.052	6.5	2.2	5.5	13.1
* 08	12	0.005	21.1	9.4	23.4	56.2	* 24	270	0.057	6.1	2.0	4.9	11.8
* 09	15	0.005	19.9	8.4	20.9	50.3	* 25	330	0.080	5.2	1.8	4.5	10.7
* 10	18	0.006	19.1	7.6	19.1	45.9	* 26	390	0.109	4.4	1.6	4.1	9.9
* 11	22	0.007	18.1	6.9	17.3	41.5	* 27	470	0.120	4.2	1.5	3.7	9.0
* 12	27	0.007	17.3	6.3	15.6	37.5	* 28	560	0.165	3.6	1.4	3.4	8.2
* 13	33	0.010	14.6	5.6	14.1	33.9							
* 14	39	0.011	14.0	5.2	13.0	31.2							
* 15	47	0.012	13.4	4.7	11.8	28.4							
* 16	56	0.013	12.8	4.3	10.8	26.0							

CTP4549