

NUD4301

Advance Information

Dual Low Dropout Voltage LED Driver/Current Source

This device is designed to replace switching regulators for driving LEDs in low voltage DC battery applications (up to 6 V). Its unique integrated circuit design provides low dropout voltage (less than 200 mV), which makes it ideal for battery applications where voltage overhead is limited. An external resistor allows the circuit designer to set the LED current for different applications needs. The device is packaged in a small surface mount leadless package (DFN8), which results in a significant reduction of both system cost and board space.

Features

- Ultra Low Dropout Voltage < 200 mV
- Programmable Output Current from 1 mA to 30 mA
- Dual Output with Independent Current Limit Set
- DC Current in LED
- Analog/Digital PWM Capability
- This is a Pb-Free Device

Typical Applications

- Portables: PDAs, Cell phones
- Li-Ion Battery Applications

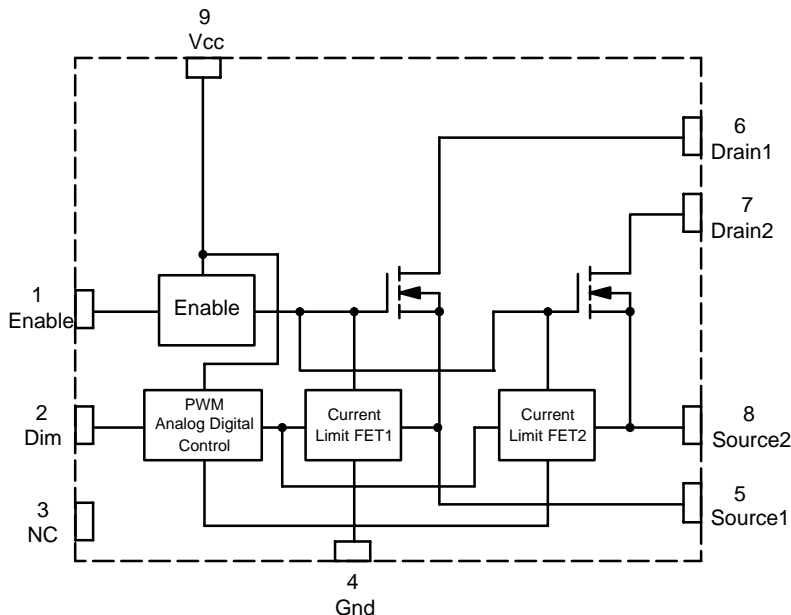

Figure 1. Block Diagram

This document contains information on a new product. Specifications and information herein are subject to change without notice.



ON Semiconductor®

<http://onsemi.com>

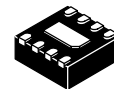

DFN8
CASE 506AQ

- 43 = Specific Device Code
- M = Date Code
- = Pb-Free Package

(Note: Microdot may be in either location)

MARKING DIAGRAM

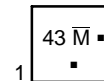

PIN CONFIGURATION

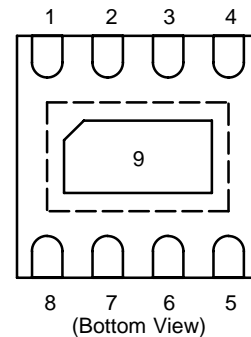

ORDERING INFORMATION

Device	Package	Shipping†
NUD4301MNT1G	DFN8 (Pb-Free)	3000/Tape & Reel

†For information on tape and reel specifications, including part orientation and tape sizes, please refer to our Tape and Reel Packaging Specification Brochure, BRD8011/D.

NUD4301

FUNCTIONAL PIN DESCRIPTIONS

Pin	Function	Description
1	Enable	The device is enabled with a positive voltage signal at this pin. The enable controls both channels.
2	Dim	This pin is used for analog or PWM dimming control. An analog signal of 0 – 3.3 volts is required, or a PWM signal with an amplitude greater than 3.3 volts. The dim controls both channels.
3	N.C.	No connection.
4	Gnd	Ground Reference to the device.
5	Source1	Source terminal of the FET 1
6	Drain1	Drain terminal of the FET 1, which is also the switching node of the load 1.
7	Drain2	Drain terminal of the FET 2, which is also the switching node of the load 2.
8	Source2	Source terminal of the FET 2
9	Vcc	Input voltage to the LED driver. This voltage is compatible with any battery based systems of up to 6 V.

MAXIMUM RATINGS

Rating	Symbol	Value	Unit
Input Voltage, Operating Steady State (V_{CC} to Gnd) Transient (1 ms)	V_{CC}	-0.3 to 6 -0.3 to 7	V
Drain Voltage, Operating Steady State (Drain-to-Source) Transient (1 ms)	V_{DS}	-0.3 to 6 -0.3 to 7	V
Enable Voltage, Operating Steady State	V_{EN}	-0.3 to 6	V
Dim Voltage, Operating Steady State	V_{dim}	-0.3 to 3.6	V
Drain Current, Peak	I_{Dpk}	100	mA
Drain Current, Continuous	$I_{D(av)}$	30	mA
Thermal Resistance, Junction-to-Air (Note 1)	Q_{JA}	365	°C/W
Power Dissipation @ $T_A = 25^\circ\text{C}$ (Note 1) Derating above 25°C	P_{max}	340 2.7	mW mW/°C
Operating Temperature Range	T_J	-40 to 150	°C
Non-Operating Temperature Range	T_J	-55 to 175	°C
Maximum Lead Temperature for Soldering Purposes (1.8" from case for 10 s)	T_L	260	°C

Stresses exceeding Maximum Ratings may damage the device. Maximum Ratings are stress ratings only. Functional operation above the Recommended Operating Conditions is not implied. Extended exposure to stresses above the Recommended Operating Conditions may affect device reliability.

1. Mounted onto minimum pad board.

NUD4301

ELECTRICAL CHARACTERISTICS (Unless otherwise noted: $V_{CC} = 3.6\text{ V}$, $R_{sense} = 4.7\ \Omega$, 1%, $T_A = 25^\circ\text{C}$ for typical values, For min/max values T_J is the applicable junction temperature)

Characteristics	Symbol	Min	Typ	Max	Unit
Power FET (Each Channel)					
ON Resistance ($V_{CC} = 3.6\text{ V}$, $I_D = 10\text{ mA}$, $R_{sense} = 4.7\ \Omega$, $V_{dim} = 3.3\text{ V}$)	R_{DSon}	–	5.0	–	Ω
Zero Enable Voltage Drain Current ($V_{DS} = 6\text{ V}$, $V_{Enable} = 0\text{ V}$)	I_{DSS}	–	1.0	–	μA
Drain-to-Source Sustaining Voltage ($I_D = 100\ \mu\text{A}$)	V_{BRDSS}	7.0	–	–	V
Output Capacitance ($V_{DS} = 6\text{ V}$, $V_{Enable} = 0\text{ V}$, $f = 1\text{ kHz}$)		–	TBD	–	pF
Voltage Drop (Note 2) ($V_{CC} = 3.6\text{ V}$, $V_{LED} = 3.4\text{ V}$, $I_D = 20\text{ mA}$, $R_{sense} = 4.7\ \Omega$, $V_{dim} = 3.3\text{ V}$)	V_{drop}	–	–	200	mV
Current Regulation Circuit (Each Channel)					
Output Current Regulation ($V_{CC} = 3.6\text{ V}$, $V_{LED} = 3.4\text{ V}$, $R_{sense} = 4.7\ \Omega$, $V_{dim} = 3.3\text{ V}$)	I_{out}	18	20	22	mA
Enable					
Logic Level High (Unit Operational)	V_{ENhigh}	1.7	–	–	V
Logic Level Low (Unit Shutdown)	V_{ENlow}	–	–	0.7	V
Dim					
Off Voltage (Zero Output Current), $I_D = 20\ \mu\text{A}$, $R_{sense} = 4.7\ \Omega$	V_{zero}	–	–	50	mV
On Voltage (Max Output Current), $I_D = I_{out}$, $R_{sense} = 4.7\ \Omega$	V_{max}	3.1	3.3	3.6	V
Max PWM Frequency	f_{max}	–	10	–	kHz
Bias Supply (Complete Device)					
Bias Current ($V_{CC} = 3.6\text{ V}$, Device Non-Operational, $V_{Enable} = 0\text{ V}$)	I_{BIAS1}	–	0.1	–	μA
Bias Current ($V_{CC} = 3.6\text{ V}$, Device Operational, $V_{Enable} = V_{CC}$)	I_{BIAS2}	–	1	–	mA

2. $V_{drop} = V_{DS} + V_{Rsense}$

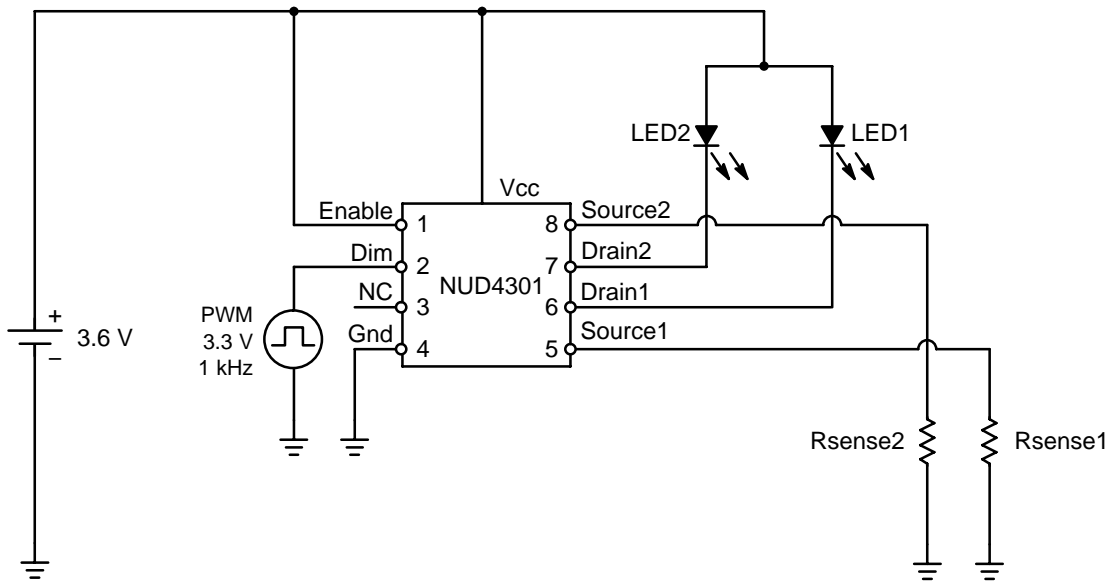

Figure 2. Typical Application Circuit

NUD4301

TYPICAL PERFORMANCE CURVES

($T_A = 25^\circ\text{C}$, unless otherwise noted)

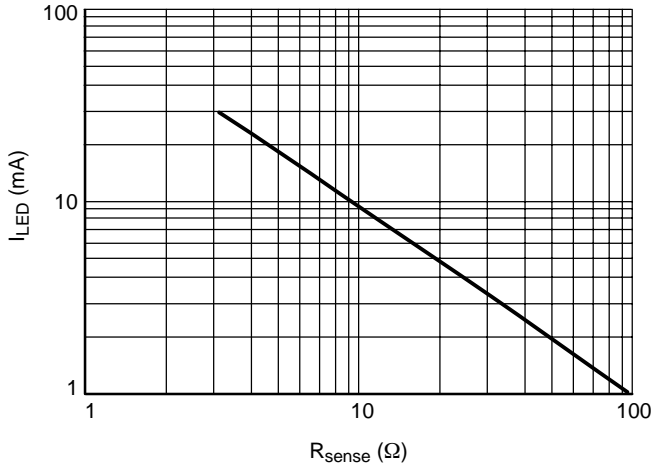

Figure 3. Current Limit Adjustment

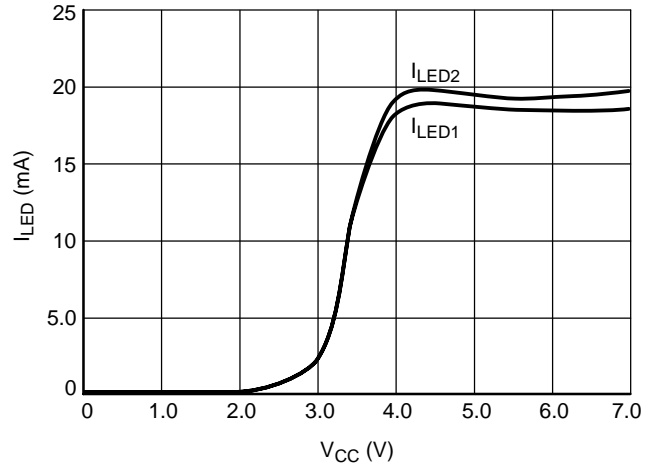

Figure 4. Typical Line Regulation Performance
($V_{LED} = 3.4\text{ V}$, $R_{sense} = 4.7\ \Omega$)

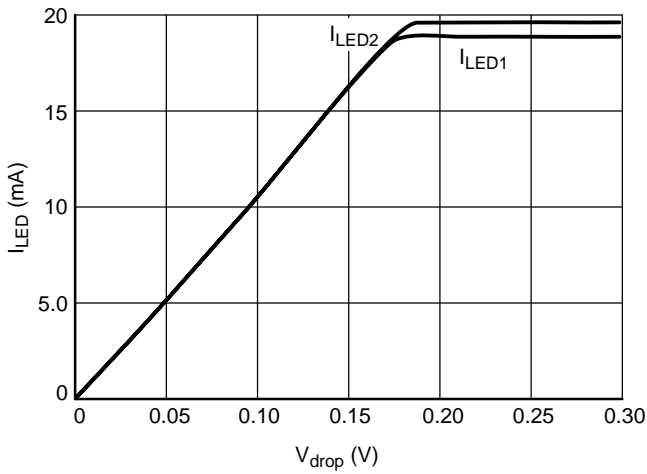

Figure 5. Typical Current Regulation vs. V_{drop}
($V_{drop} = V_{DS} + V_{R_{sense}}$)

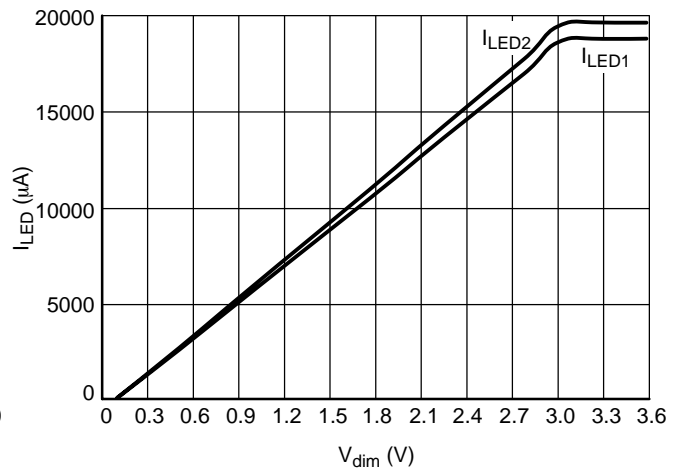

Figure 6. Typical Current Regulation vs. V_{dim}
($V_{LED} = 3.4\text{ V}$, $R_{sense} = 4.7\ \Omega$)

NUD4301

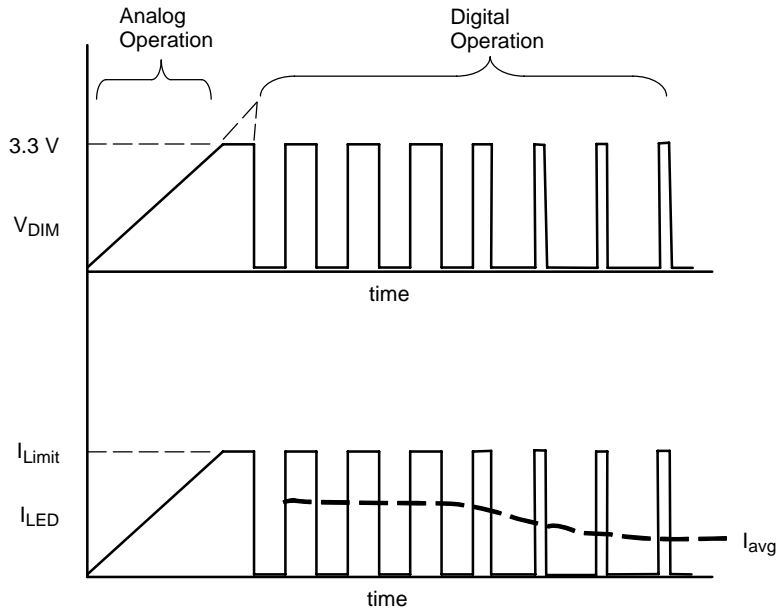

Figure 7. Dimming Operation Curves
(Graph obtained from SPICE simulations)

Theory of Operation

This device contains two LED current sources. Each channel is comprised of a lateral N-channel FET controlled by a current limit circuit that senses the voltage drop across the R_{sense} resistor and compares it with an internal voltage reference to provide the current regulation. For dimming applications, the current limit circuit operates in combination with the PWM signal applied to the dim pin of the device for control purposes.

Current Limit and PWM Circuits

With a DC voltage of 3.3 volts applied to the Dim pin of the device, the internal reference voltage of the current limit circuit is set to 93.5 mV. The R_{sense} resistor is then selected through a very simple formula: $R_{sense} = 93.5 \text{ mV} / I_{LED}$. This allows the user to set different LED currents (between 1 mA and 30 mA).

For dimming control, a PWM signal may be applied to the dim pin of the device. This PWM signal can be used to perform digital dimming.

For digital dimming, the amplitude of the PWM signal must be 3.3 V or higher. The LED current will be proportional to the duty cycle of the PWM signal.

For analog dimming, the input signal to the Dim pin must be between 0 and 3.3 volts. The resulting output current will be given by the following formula:

$$I_{LED} = \frac{(V_{dim} / 35.3)}{R_{sense}}$$

If a PWM signal is beyond the input frequency range for the Dim pin, a RC filter may be used to convert it to an analog signal.

The RC filter generates an analog voltage signal, which is proportional to the duty cycle of the PWM signal applied. This analog signal is then used as the new reference voltage for the current limit circuit, which compares it with the voltage signal generated across R_{sense} to provide the current regulation.

Enable

The enable circuit turns the device on when a positive signal is applied to the enable pin. The circuit is designed to allow low current consumption (0.1 μA typical) when the device is disabled.

NUD4301

PACKAGE DIMENSIONS

DFN8
CASE 506AQ-01
ISSUE A

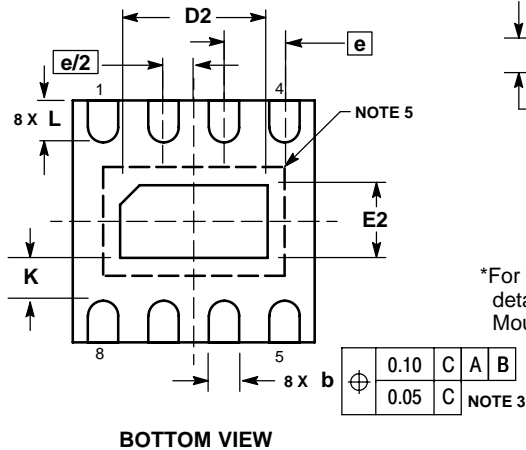
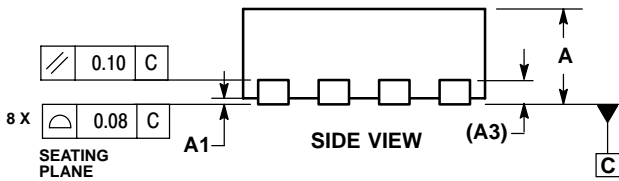
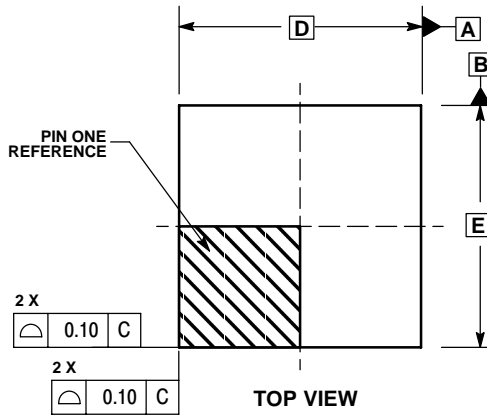

NOTES:

1. DIMENSIONING AND TOLERANCING PER ASME Y14.5M, 1994 .
2. CONTROLLING DIMENSION: MILLIMETERS.
3. DIMENSION b APPLIES TO PLATED TERMINAL AND IS MEASURED BETWEEN 0.25 AND 0.30 MM FROM TERMINAL.
4. COPLANARITY APPLIES TO THE EXPOSED PAD AS WELL AS THE TERMINALS.
5. INTERNAL PAD SIZE: 1.5 X 0.9 MM.

DIM	MILLIMETERS	
	MIN	MAX
A	0.80	1.00
A1	0.00	0.05
A3	0.20 REF	
b	0.20	0.30
D	2.00 BSC	
D2	1.10	1.30
E	2.00 BSC	
E2	0.50	0.70
e	0.50 BSC	
K	0.20	---
L	0.25	0.45

SOLDERING FOOTPRINT*

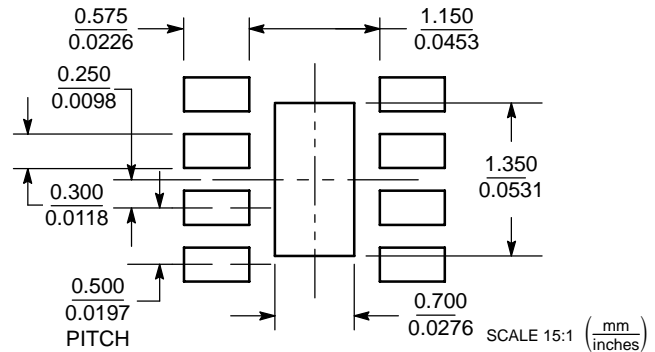

*For additional information on our Pb-Free strategy and soldering details, please download the ON Semiconductor Soldering and Mounting Techniques Reference Manual, SOLDERRM/D.

ON Semiconductor and are registered trademarks of Semiconductor Components Industries, LLC (SCILLC). SCILLC reserves the right to make changes without further notice to any products herein. SCILLC makes no warranty, representation or guarantee regarding the suitability of its products for any particular purpose, nor does SCILLC assume any liability arising out of the application or use of any product or circuit, and specifically disclaims any and all liability, including without limitation special, consequential or incidental damages. "Typical" parameters which may be provided in SCILLC data sheets and/or specifications can and do vary in different applications and actual performance may vary over time. All operating parameters, including "Typicals" must be validated for each customer application by customer's technical experts. SCILLC does not convey any license under its patent rights nor the rights of others. SCILLC products are not designed, intended, or authorized for use as components in systems intended for surgical implant into the body, or other applications intended to support or sustain life, or for any other application in which the failure of the SCILLC product could create a situation where personal injury or death may occur. Should Buyer purchase or use SCILLC products for any such unintended or unauthorized application, Buyer shall indemnify and hold SCILLC and its officers, employees, subsidiaries, affiliates, and distributors harmless against all claims, costs, damages, and expenses, and reasonable attorney fees arising out of, directly or indirectly, any claim of personal injury or death associated with such unintended or unauthorized use, even if such claim alleges that SCILLC was negligent regarding the design or manufacture of the part. SCILLC is an Equal Opportunity/Affirmative Action Employer. This literature is subject to all applicable copyright laws and is not for resale in any manner.

PUBLICATION ORDERING INFORMATION

LITERATURE FULFILLMENT:
Literature Distribution Center for ON Semiconductor
P.O. Box 5163, Denver, Colorado 80217 USA
Phone: 303-675-2175 or 800-344-3860 Toll Free USA/Canada
Fax: 303-675-2176 or 800-344-3867 Toll Free USA/Canada
Email: orderlit@onsemi.com

N. American Technical Support: 800-282-9855 Toll Free
USA/Canada
Europe, Middle East and Africa Technical Support:
Phone: 421 33 790 2910
Japan Customer Focus Center
Phone: 81-3-5773-3850

ON Semiconductor Website: www.onsemi.com
Order Literature: <http://www.onsemi.com/orderlit>

For additional information, please contact your local Sales Representative