

Features

- AVR® 8-bit RISC Microcontroller with 41.5 or 83 ns Instruction Cycle Time
- USB Hub with One Attached and Two External Ports
- USB Function with Three Programmable End-points
- 24 KB Program Memory, 1 KB Data SRAM
- 32 x 8 General-purpose Working Registers
- 15 Programmable I/O Port Pins
- 12-channel 10-bit ADC
- One 8-bit Timer/Counter with Separate Pre-scaler
- One 16-bit Timer/Counter with Separate Pre-scaler and Two PWMs
- External and Internal Interrupt Sources
- Programmable Watchdog Timer
- 6 MHz Oscillator with On-chip PLL
- 5V Operation with On-chip 3.3V Power Supply
- 48-lead LQFP Package

Description

The Atmel AT43USB353M is an 8-bit microcontroller based on the AVR RISC architecture. By executing powerful instructions in a single clock cycle, the AT43USB353M achieves throughputs approaching 24 MIPS. The AVR core combines a rich instruction set with 32 general-purpose working registers. All 32 registers are directly connected to the ALU allowing two independent registers to be accessed in one single instruction executed in one clock cycle. The resulting architecture is more code efficient while achieving throughputs up to ten times faster than conventional CISC microcontrollers.

The AT43USB353M features an on-chip 24-Kbyte of masked ROM program memory and 1-Kbyte of data memory. It is supported by a standard set of peripherals such as timer/counter modules, watchdog timer and internal and external interrupt sources. The major peripheral included in the AT43USB353M is a full-speed USB 2.0 Hub with an embedded function and a 12-channel Analog-to-Digital Converter (ADC) for use in applications such as game controllers.

The AT43USB353M is binary compatible with the AT43USB355. Program development and debugging for the AT43USB353M uses the AT43DK355, including all its tools and libraries.

Pin Configuration

Figure 1. AT43USB353M 48-lead LQFP

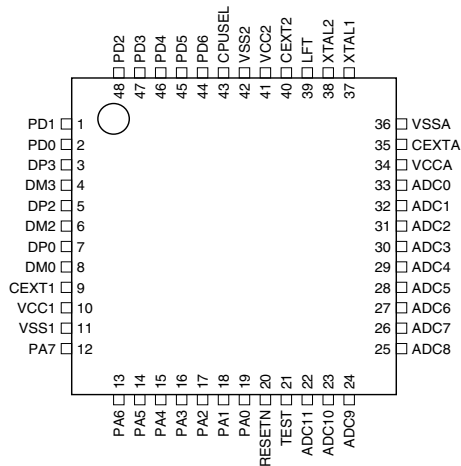

**Low Cost
Full-speed USB
Microcontroller
with Embedded
Hub, ADC and
PWM**

AT43USB353M



Pin Assignment

Pin#	Signal	Type
1	PD1	Bi-directional
2	PD0	Bi-directional
3	DP3	Bi-directional
4	DM3	Bi-directional
5	DP2	Bi-directional
6	DM2	Bi-directional
7	DP0	Bi-directional
8	DM0	Bi-directional
9	CEXT1	Power Supply/Ground
10	VCC1	Power Supply/Ground
11	VSS1	Power Supply/Ground
12	PA7	Bi-directional
13	PA6	Bi-directional
14	PA5	Bi-directional
15	PA4	Bi-directional
16	PA3	Bi-directional
17	PA2	Bi-directional
18	PA1	Bi-directional
19	PA0	Bi-directional
20	RESETN	Input
21	TEST	Input
22	ADC11	Input
23	ADC10	Input
24	ADC9	Input

Pin#	Signal	Type
25	ADC8	Input
26	ADC7	Input
27	ADC6	Input
28	ADC5	Input
29	ADC4	Input
30	ADC3	Input
31	ADC2	Input
32	ADC1	Input
33	ADC0	Input
34	VCCA	Power Supply/Ground
35	CEXTA	Power Supply/Ground
36	VSSA	Power Supply/Ground
37	XTAL1	Input
38	XTAL2	Output
39	LFT	Output
40	CEXT2	Power Supply/Ground
41	VCC2	Power Supply/Ground
42	VSS2	Power Supply/Ground
43	CPUSEL	Input
44	PD6	Bi-directional
45	PD5	Bi-directional
46	PD4	Bi-directional
47	PD3	Bi-directional
48	PD2	Bi-directional

Signal Description

Name	Type	Function												
V _{CC1, 2}	Power Supply/Ground	5V Digital Power Supply												
V _{CCA}	Power Supply/Ground	5V Power Supply for the ADC												
V _{SS1, 2}	Power Supply/Ground	Digital Ground												
V _{SSA}	Power Supply/Ground	Ground for the ADC												
CEXT1, 2	Power Supply/Ground	External Capacitors for Power Supplies – High quality 2.2 μF capacitors must be connected to CEXT1 and 2 for proper operation of the chip.												
CEXTA	Power Supply/Ground	External Capacitor for Analog Power Supply – A high quality 0.33 μF capacitor must be connected to CEXTA for proper operation of the chip.												
XTAL1	Input	Oscillator Input – Input to the inverting oscillator amplifier.												
XTAL2	Output	Oscillator Output – Output of the inverting oscillator amplifier.												
CPUSEL	Input	CPU Speed Select – This pin selects the CPU clock frequency. If high, the CPU runs at 12 MHz, if low it runs at 24 MHz.												
LFT	Input	PLL Filter – For proper operation of the PLL, this pin should be connected through a 0.01 μF capacitor in parallel with a 100Ω resistor in series with a 0.1 μF capacitor to ground (VSS). Both capacitors must be high quality ceramic.												
DPO	Bi-directional	Upstream Plus USB I/O – This pin should be connected to CEXT1 through an external 1.5 kΩ.												
DMO	Bi-directional	Upstream Minus USB I/O												
DP[2,3]	Bi-directional	Downstream Plus USB I/O – Each of these pins should be connected to VSS through an external 15 kΩ resistor. DP[2,3] and DM[2,3] are the differential signal pin pairs to connect downstream USB devices.												
DM[2,3]	Bi-directional	Downstream Minus USB I/O – Each of these pins should be connected to VSS through an external 15 kΩ resistor.												
PA[0:7]	Bi-directional	Port A[0:7] – Bi-directional 8-bit I/O port with 2 mA drive strength and a programmable pull-up resistor.												
PD[0:6]	Bi-directional	<p>Port D[0:6] – Bi-directional I/O ports with 2 mA drive strength and a programmable pull-up resistor. PortD[2,3,5,6] have dual functions as shown below:</p> <table border="1"> <thead> <tr> <th>Port Pin</th> <th>Alternate Function</th> </tr> </thead> <tbody> <tr> <td>PD2</td> <td>INT0, External Interrupt 0</td> </tr> <tr> <td>PD3</td> <td>INT1, External Interrupt 1</td> </tr> <tr> <td>PD4</td> <td>ICP, Timer/Counter/Input Capture</td> </tr> <tr> <td>PD5</td> <td>OC1A Timer/Counter1 Output Compare A</td> </tr> <tr> <td>PD6</td> <td>OC1B Timer/Counter1 Output Compare B</td> </tr> </tbody> </table>	Port Pin	Alternate Function	PD2	INT0, External Interrupt 0	PD3	INT1, External Interrupt 1	PD4	ICP, Timer/Counter/Input Capture	PD5	OC1A Timer/Counter1 Output Compare A	PD6	OC1B Timer/Counter1 Output Compare B
Port Pin	Alternate Function													
PD2	INT0, External Interrupt 0													
PD3	INT1, External Interrupt 1													
PD4	ICP, Timer/Counter/Input Capture													
PD5	OC1A Timer/Counter1 Output Compare A													
PD6	OC1B Timer/Counter1 Output Compare B													
ADC[0:11]	Input	ADC Input[0:11] – 12-bit input pins for the ADC.												
TEST	Input	Test Pin – This pin should be tied to ground.												
RESETN	Input	Reset – Active Low.												

Figure 2. The AT43USB353M Enhanced RISC Architecture

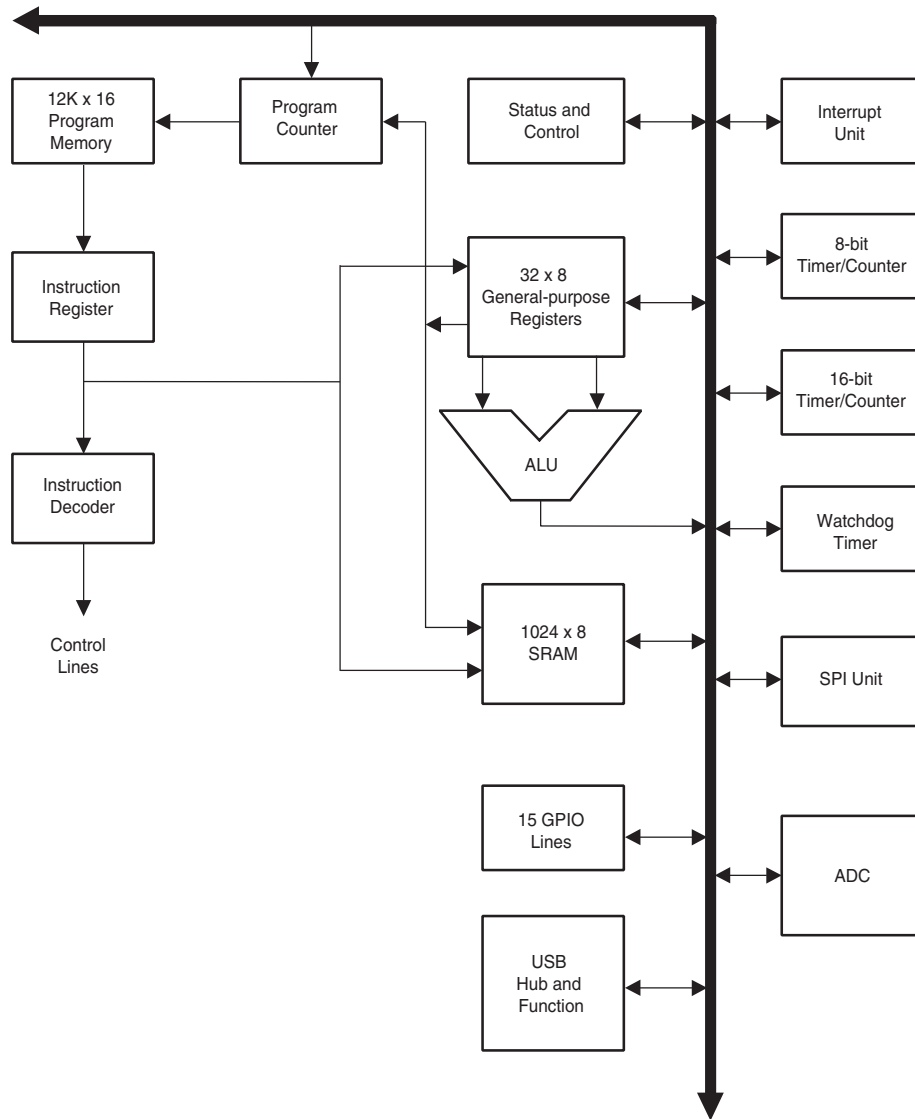

Architectural Overview

The AT43USB353M is binary compatible with the AT43USB355. Firmware development for the AT43USB355 will run on the AT43USB353M as long as only features common to both chips are used. Refer to Table 3 on page 8 for the differences between these two devices.

The peripherals and features of the AT43USB353M microcontroller are similar to those of the AT90S8515, with the exception of the following modifications:

- Masked ROM for program memory
- No EEPROM
- No external data memory accesses
- No SPI
- No UART
- Idle mode not supported
- USB Hub with attached function
- On-chip ADC

The embedded USB hardware of the AT43USB353M is a compound device, consisting of a 3 port hub with a permanently attached function on one port. The hub and attached function are two independent USB devices, each having its own device addresses and control end-points. The hub has its dedicated interrupt end-point, while the USB function has 3 additional programmable end-points with separate FIFOs. Two of the FIFOs are 64 bytes deep and the third is 8 bytes deep.

Depending on the state of the CPUSEL input pin, device pin 43, the MCU runs at 12 MHz or 24 MHz. The clock that operates the MCU is generated by the USB hardware. While at 12 MHz the nominal and average period of the clock is 83.3 ns. It may have single cycles that deviate by ± 20.8 ns during a phase adjustment by the SIE's clock/data separator of the USB hardware. The 24 MHz clock runs with a clock period of 41.67 ns that may increase to 62.5 ns for one cycle when the SIE's clock/data separator makes an adjustment. The clock frequencies of the various modules of the AT43USB353M is summarized in Table 1.

Table 1. Module Clock Frequencies

CPUSEL Pin	MCU Clock	Timer/Counter Clock	ADC Clock	WDT Clock
0	24 MHz	12 MHz	1 MHz	1 MHz
1	12 MHz	12 MHz	1 MHz	1 MHz

Note: Refer to page 15 for details of the on chip oscillator and PLL.

The microcontroller shares most of the control and status registers of the megaAVR Microcontroller Family. The registers for managing the USB operations are mapped into its SRAM space. The I/O section on page 13 summarizes the available I/O registers. The “AVR Register Set” on page 32 covers the AVR registers. Please refer to the Atmel AVR manual for more information.

The fast-access register file concept contains 32 x 8-bit general-purpose working registers with a single clock cycle access time. This means that during one single clock cycle, one Arithmetic Logic Unit (ALU) operation is executed. Two operands are output from the register file, the operation is executed, and the result is stored back in the register file – in one clock cycle.

Six of the 32 registers can be used as three 16-bit indirect address register pointers for Data Space addressing - enabling efficient address calculations. One of the three address pointers is also used as the address pointer for look-up tables in program memory. These added function registers are the 16-bit X-, Y- and Z-registers.

The ALU supports arithmetic and logic operations between registers or between a constant and a register. Single register operations are also executed in the ALU. Figure 2 on page 4 shows the AT43USB353M AVR Enhanced RISC microcontroller architecture.

In addition to the register operation, the conventional memory addressing modes can be used on the register file as well. This is enabled by the fact that the register file is assigned the 32 lowest Data Space addresses (\$00 - \$1 F), allowing them to be accessed as though they were ordinary memory locations.

The I/O memory space contains 64 addresses for CPU peripheral functions as Control Registers, Timer/Counters, and other I/O functions. The I/O Memory can be accessed directly, or as the Data Space locations following those of the register file, \$20 - \$5F.

The AVR uses a Harvard architecture concept – with separate memories and buses for program and data. The program memory is executed with a single-level pipelining. While one instruction is being executed, the next instruction is pre-fetched from the program memory. This concept enables instructions to be executed in every clock cycle. The program memory is a downloadable SRAM or a mask programmed ROM.

With the relative jump and call instructions, the whole 24K address space is directly accessed. Most AVR instructions have a single 16-bit word format. Every program memory address contains a 16- or 32-bit instruction.

During interrupts and subroutine calls, the return address Program Counter (PC) is stored on the stack. The stack is effectively allocated in the general data SRAM, and consequently, the stack size is only limited by the total SRAM size and the usage of the SRAM. All user programs must initialize the Stack Pointer (SP) in the reset routine (before subroutines or interrupts are executed). The 10-bit SP is read/write accessible in the I/O space.

The 1-Kbyte data SRAM can be easily accessed through the five different addressing modes supported in the AVR architecture.

The memory spaces in the AVR architecture are all linear and regular memory maps. A flexible interrupt module has its control registers in the I/O space with an additional global interrupt enable bit in the status register. All interrupts have a separate interrupt vector in the interrupt vector table at the beginning of the program memory. The interrupts have priority in accordance with their interrupt vector position. The lower the interrupt vector address, the higher the priority.

The General-purpose Register File

Table 2. AVR CPU General-purpose Working Register

Register	Address	Comment
R0	\$00	
R1	\$01	
R2	\$02	
..		
R13	\$0D	
R14	\$0E	
R15	\$0F	
R16	\$10	
R17	\$11	
..		
R26	\$1A	X-register low byte
R27	\$1B	X-register high byte
R28	\$1C	Y-register low byte
R29	\$1D	Y-register high byte
R30	\$1E	Z-register low byte
R31	\$1F	Z-register high byte

All register operating instructions in the instruction set have direct and single cycle access to all registers. The only exception is the five constant arithmetic and logic instructions SBCI, SUBI, CPI, ANDI, and ORI between a constant and a register, and the LDI instruction for load immediate constant data. These instructions apply to the second half of the registers in the register file – R16..R31. The general SBC, SUB, CP, AND, and OR and all other operations between two registers or on a single register apply to the entire register file.

As shown in Table 2, each register is also assigned a data memory address, mapping them directly into the first 32 locations of the user Data Space. Although not being physically implemented as SRAM locations, this memory organization provides great flexibility in access of the registers, as the X-, Y-, and Z-registers can be set to index any register in the file.

X-, Y- and Z-Registers

Registers R26..R31 contain some added functions to their general-purpose usage. These registers are address pointers for indirect addressing of the Data Space. The three indirect address registers X, Y, and Z are defined as:

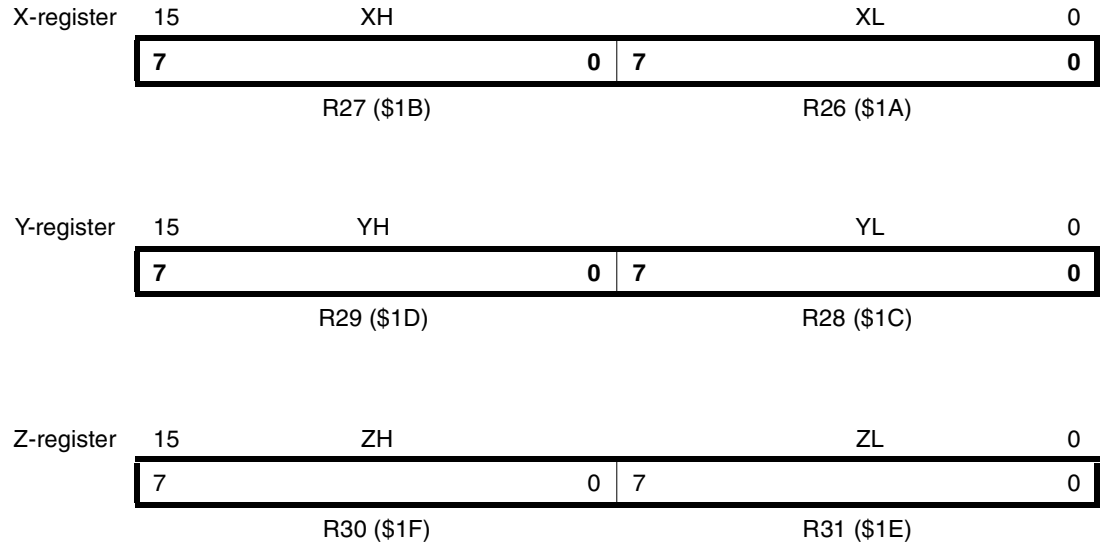

In the different addressing modes these address registers have functions as fixed displacement, automatic increment and decrement (see the descriptions for the different instructions).

ALU – Arithmetic Logic Unit

The high-performance AVR ALU operates in direct connection with all 32 general-purpose working registers. Within a single clock cycle, ALU operations between registers in the register file are executed. The ALU operations are divided into three main categories – arithmetic, logical and bit-functions.

Program Memory

The AT43USB353M contains 24K bytes on-chip masked programmable ROM program memory. Since all instructions are 16- or 32-bit words, the program memory is organized as 12K x 16. The AT43USB353M Program Counter (PC) is 14 bits wide, thus addressing the 12,288 program memory addresses.

Constant tables can be allocated within the entire program memory address space (see the LPM - Load Program Memory instruction description).

Where the functions overlap, the AT43USB353M and the AT43USB355 are binary compatible. A firmware written for the AT43USB355 will work unaltered on the AT43USB353M as long as the functions are supported by the AT43USB353M. The only functional difference between the two devices are listed in Table 3.

Table 3. Functional Difference Between AT43USB355 and AT43USB353M

Function	AT43USB355	AT43USB353M
Port B	PB[0:7]	No Port B
Port D	PD[0:7]	PD[0:6]
Port F	PF[0:3]	No Port F
External Counter Input	Yes, T0 = PB0, T1 = PB1	No T0, T1
SPI	Yes	No SPI
Analog Reference Input	External	Internally connected to CEXTA

SRAM Data Memory

Table 5 summarizes how the AT43USB353M SRAM Memory is organized. The lower 1120 Data Memory locations address the Register file, the I/O Memory and the internal data SRAM. The first 96 locations address the Register File + I/O Memory, and the next 1024 locations address the internal data SRAM. The five different addressing modes for the data memory cover: Direct, Indirect with Displacement, Indirect, Indirect with Pre-decrement and Indirect with Post-increment. In the register file, registers R26 to R31 feature the indirect addressing pointer registers. Direct addressing reaches the entire data space.

The Indirect with Displacement mode features 63 address locations that reach from the base address given by the Y- or Z-register.

When using register indirect addressing modes with automatic pre-decrement and post-increment, the address registers X, Y, and Z are decremented and incremented.

The 32 general-purpose working registers, 64 I/O registers and the 1024 bytes of internal data SRAM in the AT43USB353M are all accessible through these addressing modes.

To manage the USB hardware, a special set of registers is assigned. These registers are mapped to SRAM space between addresses \$1F00 and 1FFF. Table 5 and Table 6 give an overview of these registers.

Table 4. SRAM Organization

Register File		Data Address Space
R0		\$0000
R1		\$0001
R30		\$001E
R31		\$001F

I/O Registers

\$00		\$0020
\$01		\$0021
\$3E		\$005E
\$3F		\$005F

Internal SRAM

\$0060
\$0061
\$025E
\$045F

USB Registers

\$1F00
\$1FFE
\$1FFF

Table 5. USB Hub and Function Registers

Address	Name	Function
\$1FFD	FRM_NUM_H	Frame Number High Register
\$1FFC	FRM_NUM_L	Frame Number Low Register
\$1FFB	GLB_STATE	Global State Register
\$1FFA	SPRSR	Suspend/Resume Register
\$1FF9	SPRSIE	Suspend/Resume Interrupt Enable Register
\$1FF8	SPRSMK	Suspend/Resume Interrupt Mask Register
\$1FF7	UISR	USB Interrupt Status Register
\$1FF6	UIMSKR	USB Interrupt Mask Register
\$1FF5	UIAR	USB Interrupt Acknowledge Register
\$1FF3	UIER	USB Interrupt Enable Register
\$1FF2	UOVGER	Overcurrent Detect Register
\$1FEF	HADDR	Hub Address Register
\$1FEE	FADDR	Function Address Register
\$1FE7	HEND-P0_CNTR	Hub End-point 0 Control Register
\$1FE5	FEND-P0_CNTR	Function End-point 0 Control Register
\$1FE4	FEND-P1_CNTR	Function End-point 1 Control Register
\$1FE3	FEND-P2_CNTR	Function End-point 2 Control Register
\$1FE2	FEND-P3_CNTR	Function End-point 3 Control Register
\$1FDF	HCSR0	Hub Controller End-point 0 Service Routine Register
\$1FDD	FCSR0	Function Controller End-point 0 Service Routine Register
\$1FDC	FCSR1	Function Controller End-point 1 Service Routine Register
\$1FDB	FCSR2	Function Controller End-point 2 Service Routine Register
\$1FDA	FCSR3	Function Controller End-point 3 Service Routine Register
\$1FD7	HDR0	Hub End-point 0 FIFO Data Register
\$1FD5	FDR0	Function End-point 0 FIFO Data Register
\$1FD4	FDR1	Function End-point 1 FIFO Data Register
\$1FD3	FDR2	Function End-point 2 FIFO Data Register
\$1FD2	FDR3	Function End-point 3 FIFO Data Register
\$1FCF	HBYTE_CNT0	Hub End-point 0 Byte Count Register
\$1FCD	FBYTE_CNT0	Function End-point 0 Byte Count Register
\$1FCC	FBYTE_CNT1	Function End-point 1 Byte Count Register
\$1FCB	FBYTE_CNT2	Function End-point 2 Byte Count Register
\$1FCA	FBYTE_CNT3	Function End-point 3 Byte Count Register
\$1FC7	HSTR	Hub Status Register
\$1FC5	HPCON	Hub Port Control Register

Table 5. USB Hub and Function Registers (Continued)

Address	Name	Function
\$1FBA	HPSTAT3	Hub Port 3 Status Register
\$1FB9	HPSTAT2	Hub Port 2 Status Register
\$1FB8	HPSTAT1	Hub Port 1 Status Register
\$1FB2	HPSCR3	Hub Port 3 Status Change Register
\$1FB1	HPSCR2	Hub Port 2 Status Change Register
\$1FB0	HPSCR1	Hub Port 1 Status Change Register
\$1FAA	PSTATE3	Hub Port 3 Bus State Register
\$1FA9	PSTATE2	Hub Port 2 Bus State Register
\$1FA7	HCAR0	Hub End-point 0 Control and Acknowledge Register
\$1FA5	FCAR0	Function End-point 0 Control and Acknowledge Register
\$1FA4	FCAR1	Function End-point 1 Control and Acknowledge Register
\$1FA3	FCAR2	Function End-point 2 Control and Acknowledge Register
\$1FA2	FCAR3	Function End-point 3 Control and Acknowledge Register



Table 6. USB Hub and Function Registers

Name	Address	Bit 7	Bit 6	Bit 5	Bit 4	Bit 3	Bit 2	Bit 1	Bit 0
GLB_STATE	\$1FFB	–			SUSP FLG	RESUME FLG	RMWUPE	CONFIG	HADD EN
SPRSR	\$1FFA	–	–	–	–	–	FRWUP	RSM	GLB SUSP
SPRSIE	\$1FF9	–	–	–	–	–	FRWUP IE	RSM IE	GLB SUSP IE
SPRSMK	\$1FF8	–	–	–	–	–	FRWUP MSK	RSM MSK	GLB SUSP MSK
UISR	\$1FF7	SOF INT	EOF2 INT	–	FEP3 INT	HEP0 INT	FEP2 INT	FEP1 INT	FEP0 INT
UIMSKR	\$1FF6	SOF MSK	SOF2 MSK	–	FEP3 MSK	HEP0 MSK	FEP2 MSK	FEP1 MSK	FEP0 MSK
UIAR	\$1FF5	SOF INTACK	EOF2 INTACK	–	FEP3 INTACK	HEP0 INTACK	FEP2 INTACK	FEP1 INTACK	FEP0 INTACK
UIER	\$1FF3	SOF IE	EOF2 IE	–	FEP3 IE	HEP0 IE	FEP2 IE	FEP1 IE	FEP0 IE
UOVCCR	\$1FF2	–	–	–	–	OVC3	OVC2	–	–
HADDR	\$1FEF	SAEN	HADD6	HADD5	HADD4	HADD3	HADD2	HADD1	HADD0
FADDR	\$1FEE	FEN	FADD6	FADD5	FADD4	FADD3	FADD2	FADD1	FADD0
HEND-P0_CNTR	\$1FE7	EPEN	–	–	–	DTGLE	EPDIR	EPTYPE1	EPTYPE0
FEND-P0_CNTR	\$1FE5	EPEN	–	–	–	DTGLE	EPDIR	EPTYPE1	EPTYPE0
FEND-P1_CNTR	\$1FE4	EPEN	–	–	–	DTGLE	EPDIR	EPTYPE1	EPTYPE0
FEND-P2_CNTR	\$1FE3	EPEN	–	–	–	DTGLE	EPDIR	EPTYPE1	EPTYPE0
FEND-P3_CNTR	\$1FE2	EPEN	–	–	–	DTGLE	EPDIR	EPTYPE1	EPTYPE0
HCSR0	\$1FDF	–	–	–	–	STALL SENT	RX SETUP	RX OUT PACKET	TX COMPLETE
FCSR0	\$1FDD	–	–	–	–	STALL SENT	RX SETUP	RX OUT PACKET	TX COMPLETE
FCSR1	\$1FDC	–	–	–	–	STALL SENT	–	RX OUT PACKET	TX COMPLETE
FCSR2	\$1FDB	–	–	–	–	STALL SENT	–	RX OUT PACKET	TX COMPLETE
FCSR3	\$1FDA	–	–	–	–	STALL SENT	–	RX OUT PACKET	TX COMPLETE
HDR0	\$1FD7	DATA7	DATA6	DATA5	DATA4	DATA3	DATA2	DATA1	DATA0
FDR0	\$1FD5	DATA7	DATA6	DATA5	DATA4	DATA3	DATA2	DATA1	DATA0
FDR1	\$1FD4	DATA7	DATA6	DATA5	DATA4	DATA3	DATA2	DATA1	DATA0
FDR2	\$1FD3	DATA7	DATA6	DATA5	DATA4	DATA3	DATA2	DATA1	DATA0
FDR3	\$1FD2	DATA7	DATA6	DATA5	DATA4	DATA3	DATA2	DATA1	DATA0
HBYTE_CNT0	\$1FCF	–	–	BYTCT5	BYTCT4	BYTCT3	BYTCT2	BYTCT1	BYTCT0
FBYTE_CNT0	\$1FCD	–	–	BYTCT5	BYTCT4	BYTCT3	BYTCT2	BYTCT1	BYTCT0
FBYTE_CNT1	\$1FCC	–	BYTCT6	BYTCT5	BYTCT4	BYTCT3	BYTCT2	BYTCT1	BYTCT0
FBYTE_CNT2	\$1FCB	–	BYTCT6	BYTCT5	BYTCT4	BYTCT3	BYTCT2	BYTCT1	BYTCT0
FBYTE_CNT3	\$1FCA	–	–	BYTCT5	BYTCT4	BYTCT3	BYTCT2	BYTCT1	BYTCT0
HSTR	\$1FC7	–	–	–	–	OVLSC	LPSC	OVI	LPS
HPCON	\$1FC5	–	HPCON2	HPCON1	HPCON0	–	HPADD2	HPADD1	HPADD0
HPSTAT3	\$1FBA	–	LSP	PPSTAT	PRSTAT	POCI	PSSTAT	PESTAT	PCSTAT
HPSTAT2	\$1FB9	–	LSP	PPSTAT	PRSTAT	POCI	PSSTAT	PESTAT	PCSTAT
HPSTAT1	\$1FB8	–	LSP	PPSTAT	PRSTAT	POCI	PSSTAT	PESTAT	PCSTAT
HPSCR3	\$1FB2	–	–	–	RSTSC	POCIC	PSSC	PESC	PCSC
HPSCR2	\$1FB1	–	–	–	RSTSC	POCIC	PSSC	PESC	PCSC
HPSCR1	\$1FB0	–	–	–	RSTSC	POCIC	PSSC	PESC	PCSC
PSTATE3	\$1FAA	–	–	–	–	–	–	DPSTATE	DMSTATE
PSTATE2	\$1FA9	–	–	–	–	–	–	DPSTATE	DMSTATE
HCAR0	\$1FA7	CTL DIR	DATA END	FORCE STALL	TX PACKET READY	STALL_SENT-ACK	RX_SETUP_ACK	RX_OUT_PACKET_ACK	TX_COMPLETE-ACK
FCAR0	\$1FA5	CTL DIR	DATA END	FORCE STALL	TX PACKET READY	STALL_SENT-ACK	RX_SETUP_ACK	RX_OUT_PACKET_ACK	TX_COMPLETE-ACK
FCAR1	\$1FA4	CTL DIR	DATA END	FORCE STALL	TX PACKET READY	STALL_SENT-ACK	–	RX_OUT_PACKET_ACK	TX_COMPLETE-ACK
FCAR2	\$1FA3	CTL DIR	DATA END	FORCE STALL	TX PACKET READY	STALL_SENT-ACK	–	RX_OUT_PACKET_ACK	TX_COMPLETE-ACK
FCAR3	\$1FA2	CTL DIR	DATA END	FORCE STALL	TX PACKET READY	STALL_SENT-ACK	–	RX_OUT_PACKET_ACK	TX_COMPLETE-ACK

I/O Memory

The I/O space definition of the AT43USB353M is shown in Table 7:

Table 7. I/O Memory Space

I/O (SRAM) Address	Name	Function
\$3F (\$5F)	SREG	Status Register
\$3E (\$5E)	SPH	Stack Pointer High
\$3D (\$5D)	SPL	Stack Pointer Low
\$3B (\$5B)	GIMSK	General Interrupt Mask Register
\$3A (\$5A)	GIFR	General Interrupt Flag Register
\$39 (\$59)	TIMSK	Timer/Counter Interrupt Mask Register
\$38 (\$58)	TIFR	Timer/Counter Interrupt Mask Register
\$35 (\$55)	MCUCR	MCU General Control Register
\$33 (\$53)	TCCR0	Timer/Counter0 Control Register
\$32 (\$52)	TCNT0	Timer/Counter0 (8 bit)
\$2F (\$4F)	TCCR1A	Timer/Counter1 Control Register A
\$2E (\$4E)	TCCR1B	Timer/Counter1 Control Register B
\$2D (\$52)	TCNT1H	Timer/Counter1 High Byte
\$2C (\$52)	TCNT1L	Timer/Counter1 Low Byte
\$2B (\$4B)	OCR1AH	Timer/Counter1 Output Compare Register A High Byte
\$2A (\$4A)	OCR1AL	Timer/Counter1 Output Compare Register A Low Byte
\$29 (\$49)	OCR1BH	Timer/Counter1 Output Compare Register B High Byte
\$28 (\$48)	OCR1BL	Timer/Counter1 Output Compare Register B Low Byte
\$25 (\$45)	ICR1H	T/C 1 Input Capture Register High Byte
\$24 (\$44)	ICR1L	T/C 1 Input Capture Register Low Byte
\$21 (\$41)	WDTCR	Watchdog Timer Counter Register
\$1B (\$4B)	PORTA	Data Register, Port A
\$1A (\$3A)	DDRA	Data Direction Register, Port A
\$19 (\$39)	PINA	Input Pins, Port A
\$12 (\$32)	PORTD	Data Register, Port D
\$11 (\$31)	DDRD	Data Direction Register, Port D
\$10 (\$30)	PIND	Input Pins, Port D
\$08 (\$28)	ADCH	ADC Mux Select Register
\$07 (\$27)	ADCL	ADC Control and Status Register
\$03 (\$23)	ADCH	ADC High Byte Data Register
\$02 (\$22)	ADCL	ADC Low Byte Data Register

All AT43USB353M I/O and peripherals, except for the USB hardware registers, are placed in the I/O space. The I/O locations are accessed by the IN and OUT instructions transferring data between the 32 general-purpose working registers and the I/O space. I/O registers within the

address range \$00 – \$1F are directly bit-accessible using the SBI and CBI instructions. In these registers, the value of single bits can be checked by using the SBIS and SBIC instructions. Refer to the instruction set documentations of the AVR for more details. When using the I/O specific commands, IN and OUT, the I/O address \$00 – \$3F must be used. When addressing I/O registers as SRAM, \$20 must be added to this address. All I/O register addresses throughout this document are shown with the SRAM address in parentheses.

For compatibility with future devices, reserved bits should be written to zero if accessed. Reserved I/O memory addresses should never be written.

USB Hub

A block diagram of the USB hardware of the AT43USB353M is shown in Figure 3. The USB hub of the AT43USB353M has 3 downstream ports. The embedded function is permanently attached to Port 1. Ports 2 and 3 are available as external ports. The actual number of ports used is strictly defined by the firmware of the AT43USB353M and can vary from 0 to 2. Because the exact configuration is defined by firmware, ports 2 and 3 may even function as permanently attached ports as long as the Hub Descriptor identifies them as such.

USB Function

The embedded USB function has its own device address and has a default end-point plus 3 other programmable end-points. Two of these end-points contain their own 64-byte FIFO while the third end-point has an 8-byte FIFO. End-points 1 - 3 can be programmed as interrupt IN or OUT or bulk IN or OUT end-points.

Figure 3. USB Hardware

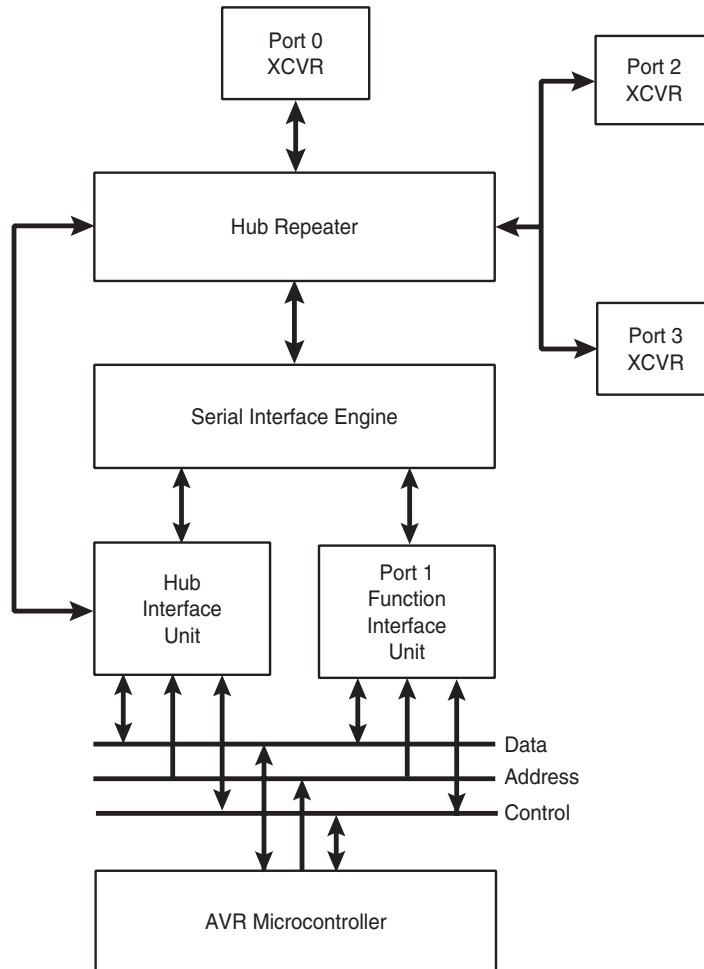

Functional Description

On-chip Power Supply

The AT43USB353M contains three on-chip power supplies that generate 3.3V with a capacity of 30 mA each from the 5V power input. The on-chip power supplies are intended to supply the AT43USB353M internal circuit and the 1.5K pull-up resistor only and should not be used for other purposes. External 2.2 μ F filter capacitors are required at the power supply outputs, CEXT1 and CEXT2, and a 0.33 μ F capacitor at CEXTA. The internal power supplies can be disabled as described in the next paragraph.

The user should be careful when the GPIO pins are required to supply high-load currents. If the application requires that the GPIO supply currents beyond the capability of the on-chip power supply, the AT43USB353M should be supplied by an external 3.3V power supply. In this case, the 5V V_{CC} power supply pin should be left unconnected and the 3.3V power supplied to the chip through the CEXT1, CEXT2 and CEXTA pins.

I/O Pin Characteristics

The I/O pins of the AT43USB353M should not be directly connected to voltages less than V_{SS} or more than the voltage at the CEXTx pins. If it is necessary to violate this rule, insert a series resistor between the I/O pin and the source of the external signal source that limits the current into the I/O pin to less than 2 mA. Under no circumstance should the external voltage exceed 5.5V. To do so will put the chip under excessive stress.

Oscillator and PLL

All clock signals required to operate the AT43USB353M are derived from an on-chip oscillator. To reduce EMI and power dissipation, the oscillator is designed to operate with a 6 MHz crystal. An on-chip PLL generates the high frequency for the clock/data separator of the Serial Interface Engine. In the suspended state, the oscillator circuitry is turned off.

The oscillator of the AT43USB353M is a special, low-drive type, designed to work with most crystals without any external components. The crystal must be of the parallel resonance type requiring a load capacitance of about 10 pF. If the crystal requires a higher value capacitance, external capacitors can be added to the two terminals of the crystal and ground to meet the required value. To assure quick start-up, a crystal with a high Q, or low ESR, should be used. To meet the USB hub frequency accuracy and stability requirements for hubs, the crystal should have an accuracy and stability of better than 100 PPM. The use of a ceramic resonator in place of the crystal is not recommended because a resonator would not have the necessary frequency accuracy and stability.

The clock can also be externally sourced. In this case, connect the clock source to the XTAL1 pin, while leaving XTAL2 pin floating. The switching level at the OSC1 pin can be as low as 0.47V and a CMOS device is required to drive this pin to maintain good noise margins at the low switching level.

For proper operation of the PLL, an external RC filter consisting of a series RC network of 100 Ω and 0.1 μ F in parallel with a 0.01 μ F capacitor must be connected from the LFT pin to V_{SS} . Use only high-quality ceramic capacitors.

Figure 4. Oscillator and PLL

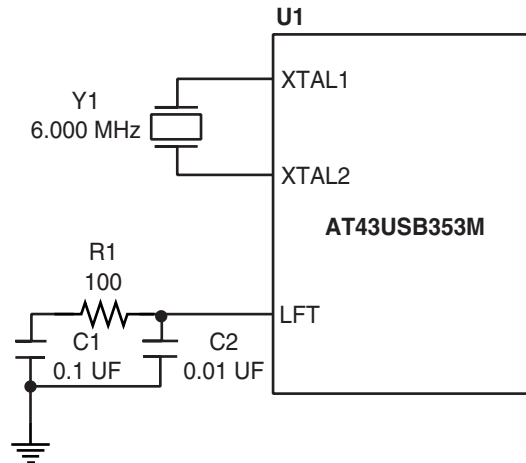

Reset and Interrupt Handling

The AT43USB353M provides 19 different interrupt sources with 10 separate reset vectors, each with a separate program vector in the program memory space. Eleven of the interrupt sources share 2 interrupt reset vectors. These 11 are the USB related interrupts. All interrupts are assigned individual enable bits which must be set (one) together with the I-bit in the status register in order to enable the interrupt.

The lowest addresses in the program memory space are automatically defined as the Reset and Interrupt vectors. The complete list of vectors is shown in Table 8. The list also determines the priority levels of the different interrupts. The lower the address, the higher is the priority level. RESET has the highest priority, and next is INT0 – the USB Suspend and Resume Interrupt, etc.

Table 8. Reset and Interrupt Vectors

Vector No.	Program Address	Source	Interrupt Definition
1	\$000	RESET	External Reset, Power-on Reset and Watchdog Reset
2	\$002	INT0	USB Suspend and Resume
3	\$004	INT1	External Interrupt Request 1
4	\$006	TIMER1 CAPT	Timer/Counter1 Capture Event
5	\$008	TIMER1 COMPA	Timer/Counter1 Compare Match A
6	\$00A	TIMER1 COMPB	Timer/Counter1 Compare Match B
7	\$00C	TIMER1, OVF	Timer/Counter1 Overflow
8	\$00E	TIMER0, OVF	Timer/Counter0 Overflow
12	\$016	ADC	ADC Conversion Complete
13	\$018	USB HW	USB Hardware

The most typical and general program setup for the Reset and Interrupt Vector Addresses are:

Address	Labels	Code	Comments
\$000		jmp RESET	; Reset Handler
\$004		jmp EXT_INT1	; IRQ1 Handler
\$00E		jmp TIM0_OVF	; Timer0 Overflow Handler
\$018		jmp USB_HW	; USB Handler
;			
\$00d	MAIN:	ldi r16, high (RAMEND)	; Main Program
start			
\$00e		out SPH, r16	
\$00f		ldi r16, low (RAMEND)	
\$010		out SPL, r16	
\$011		<instr> xxx	
...

USB related interrupt events are routed to reset vectors 13 and 2 through a separate set of interrupt, interrupt enable and interrupt mask registers that are mapped to the data SRAM space. These interrupts must be enabled through their control register bits. In the event an interrupt is generated, the source of the interrupt is identified by reading the interrupt registers. The USB frame and transaction related interrupt events, such as Start of Frame interrupt, are grouped in one set of registers: USB Interrupt Flag Register, USB Interrupt Enable Register and USB Interrupt Mask Register. The USB Bus reset and suspend/resume are grouped in another set of registers: Suspend/Resume Register, Suspend/Resume Interrupt Enable Register and Suspend/Resume Interrupt Mask Register.

Some applications may include firmware routines lasting periods that cannot be interrupted. At the same time, other less critical events may need attention after the critical routine is completed. The AT43USB353M solves this problem by having interrupt mask registers in addition to the interrupt enable registers of the USB related interrupts. The difference between the mask and enable registers is:

- The enable register enables the interrupt so it is captured into the interrupt register. If it is not enabled and an interrupt occurs, the interrupt will be lost.
- The mask register merely masks the interrupt from interrupting the CPU. Upon unmasking, the pending interrupt is triggered.

Figure 5. AT43USB353M Interrupt Structure

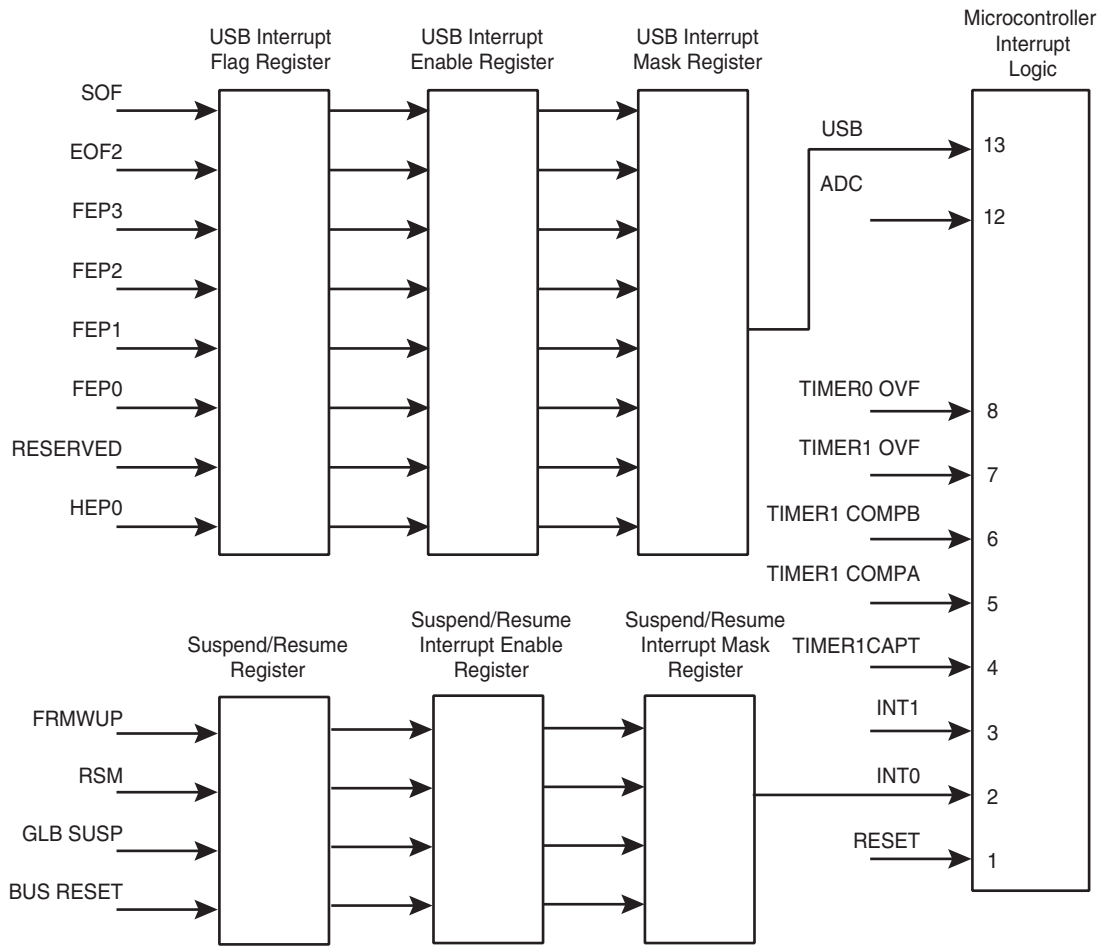

Reset Sources

The AT43USB353M has four sources of reset:

- **Power-on Reset** – The MCU is reset when the supply voltage is below the power-on reset threshold.
- **External Reset** – The MCU is reset when a low level is present on the RESETP pin for more than 50 ns.
- **Watchdog Reset** – The MCU is reset when the watchdog timer period expires and the watchdog is enabled.
- **USB Reset** – The AT43USB353M has a feature to separate the USB and microcontroller resets. This feature is enabled by setting the BUS INT EN, bit 3 of the SPRSIE register. A USB bus reset is defined as a SE0 (single ended zero) of at least 4 slow speed USB clock cycles received by Port0. The internal reset pulse to the USB hardware and microcontroller lasts for 24 oscillator periods.
 - Resets not separated: A USB bus reset will also reset the microcontroller.
 - Separated reset: A USB bus reset will only reset the USB hardware, while an interrupt to the microcontroller will be generated if the BUS INT MSK bit, bit 3 of SPRSMK register, is also set.

When the USB hardware is reset, the compound device is de-configured and has to be re-enumerated by the host. When the microcontroller is reset, all I/O registers are then set to their initial values, and the program starts execution from address \$000. The instruction placed in

address \$000 must be a JMP instruction to the reset handling routine. If the program never enables an interrupt source, the interrupt vectors are not used, and regular program code can be placed at these locations. The circuit diagram in Figure 6 shows the reset logic.

Figure 6. Reset Logic

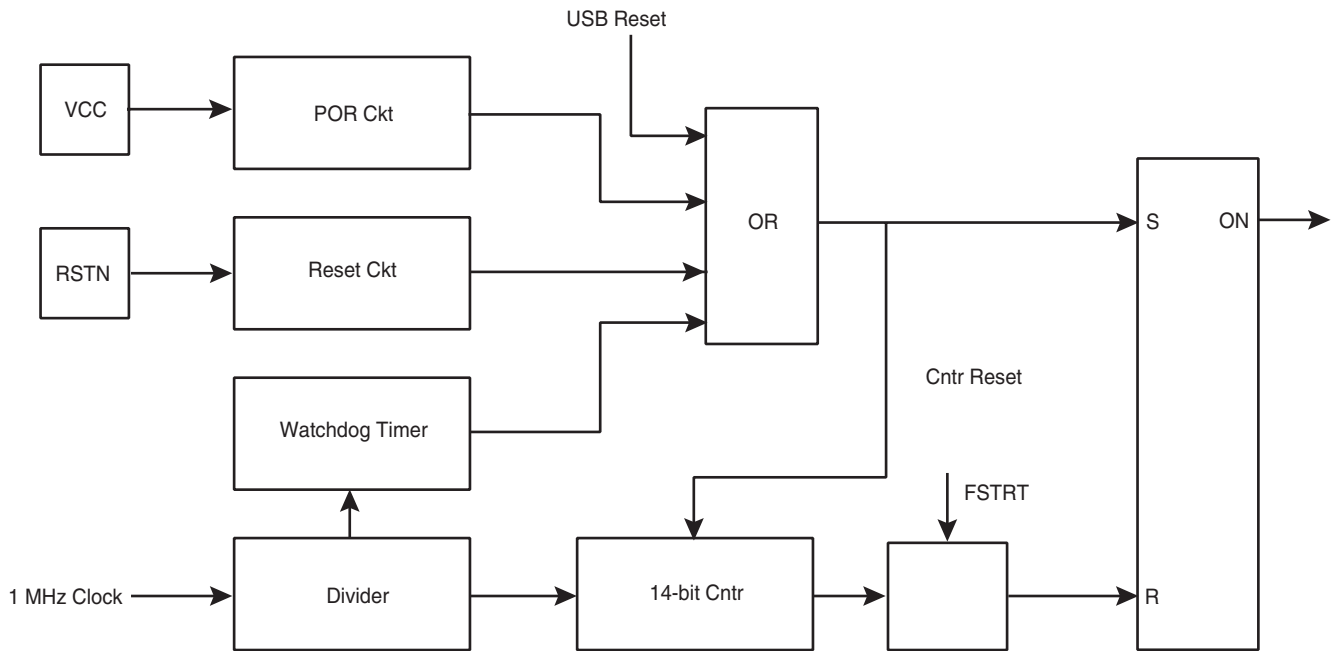

Power-on Reset

A Power-on Reset (POR) circuit ensures that the device is reset from power-on. An internal timer clocked from the Watchdog timer oscillator prevents the MCU from starting until after a certain period after V_{CC} has reached the power-on threshold voltage, regardless of the V_{CC} rise time.

If the build-in start-up delay is sufficient, RESETN can be connected to V_{CC} directly or via an external pull-up resistor. By holding the pin low for a period after V_{CC} has been applied, the Power-on Reset period can be extended.

External Reset

An external reset is generated by a low-level on the RESETN pin. Reset pulses longer than 200 ns will generate a reset. Shorter pulses are not guaranteed to generate a reset. When the applied signal reaches the Reset Threshold Voltage - V_{RST} on its positive edge, the delay timer starts the MCU after the Time-out period t_{TOUT} has expired.

Figure 7. External Reset During Operation

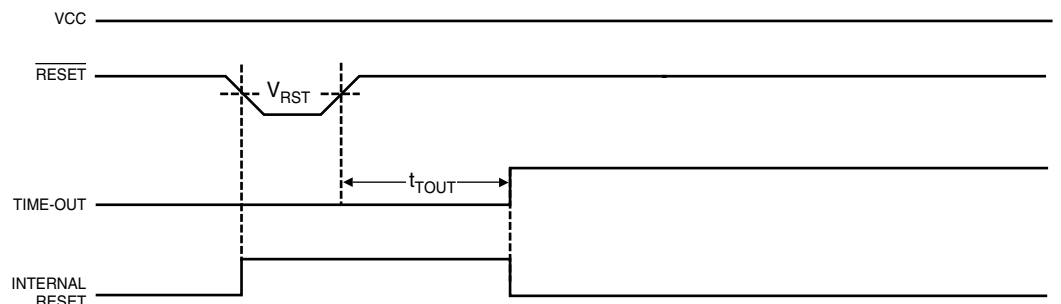

Watchdog Timer Reset

When the watchdog times out, it will generate a short reset pulse of 1 XTAL cycle duration. On the falling edge of this pulse, the delay timer starts counting the Time-out period t_{TOUT} .

Figure 8. Watchdog Reset During Operation

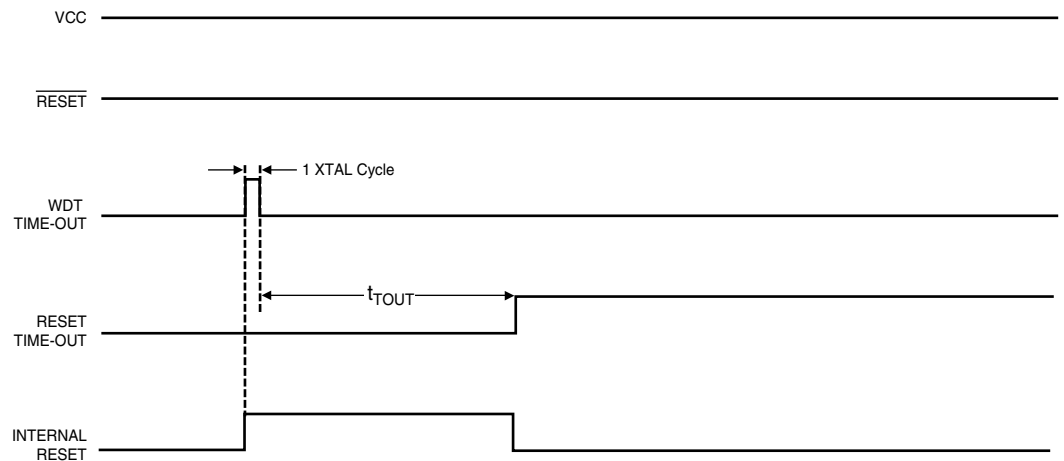

Non-USB Related Interrupt Handling

The AT43USB353M has two non-USB 8-bit Interrupt Mask control registers; GIMSK (General Interrupt Mask Register) and TIMSK (Timer/Counter Interrupt Mask Register).

When an interrupt occurs, the Global Interrupt Enable I-bit is cleared (zero) and all interrupts are disabled. The user software can set (one) the I-bit to enable nested interrupts. The I-bit is set (one) when a Return from Interrupt instruction, RETI, is executed.

For Interrupts triggered by events that can remain static (e.g. the Output Compare register1 matching the value of Timer/Counter1) the interrupt flag is set when the event occurs. If the interrupt flag is cleared and the interrupt condition persists, the flag will not be set until the event occurs the next time.

When the Program Counter is vectored to the actual interrupt vector in order to execute the interrupt handling routine, hard-ware clears the corresponding flag that generated the interrupt. Some of the interrupt flags can also be cleared by writing a logic one to the flag bit position(s) to be cleared.

If an interrupt condition occurs when the corresponding interrupt enable bit is cleared (zero), the interrupt flag will be set and remembered until the interrupt is enabled, or the flag is cleared by software.

If one or more interrupt conditions occur when the global interrupt enable bit is cleared (zero), the corresponding interrupt flag(s) will be set and remembered until the global interrupt enable bit is set (one), and will be executed by order of priority.

Note that external level interrupt does not have a flag, and will only be remembered for as long as the interrupt condition is active.

General Interrupt Mask Register – GIMSK

Bit	7	6	5	4	3	2	1	0	
\$3B (\$5B)	INT1	INT0	–	–	–	–	–	–	GIMSK
Read/Write	R/W	R/W	R	R	R	R	R	R	
Initial Value	0	0	0	0	0	0	0	0	

- **Bit 7 – INT1: External Interrupt Request 1 Enable**

When the INT1 bit is set (one) and the I-bit in the Status Register (SREG) is set (one), the external pin interrupt is enabled. The Interrupt Sense Control1 bits 1/0 (ISC11 and ISC10) in the MCU general Control Register (MCUCR) defines whether the external interrupt is activated on rising or falling edge of the INT1 pin or level sensed. Activity on the pin will cause an interrupt request even if INT1 is configured as an output. The corresponding interrupt of External Interrupt Request 1 is executed from program memory address \$004. See also “External Interrupts” on page 24.

- **Bit 6 – INT0: Interrupt Request 0 (Suspend/Resume Interrupt) Enable**

When the INT0 bit is set (one) and the I-bit in the Status Register (SREG) is set (one), the external pin interrupt is enabled. The Interrupt Sense Control0 bits 1/0 (ISC01 and ISC00) in the MCU general Control Register (MCUCR) defines whether the external interrupt is activated on rising or falling edge of the INT0 pin or level sensed. Activity on the pin will cause an interrupt request even if INT0 is configured as an output. The corresponding interrupt of Interrupt Request 0 is executed from program memory address \$002. See also “External Interrupts” on page 24.

- **Bits 5..0 – Res: Reserved Bits**

These bits are reserved bits in the AT43USB353M and always read as zero.

General Interrupt Flag Register – GIFR

Bit	7	6	5	4	3	2	1	0	
\$3A (\$5A)	INTF1	INTF0	–	–	–	–	–	–	GIFR
Read/Write	R/W	R/W	R	R	R	R	R	R	
Initial Value	0	0	0	0	0	0	0	0	

- **Bit 7 – INTF1: External Interrupt Flag1**

When an event on the INT1 pin triggers an interrupt request, INTF1 becomes set (one). If the I-bit in SREG and the INT1 bit in GIMSK are set (one), the MCU will jump to the interrupt vector at address \$004. The flag is cleared when the interrupt routine is executed. Alternatively, the flag can be cleared by writing a logical one to it.

- **Bit 6 – INTF0: Interrupt Flag0 (Suspend/Resume Interrupt Flag)**

When an event on the INT0 (that is, a USB event-related interrupt) triggers an interrupt request, INTF0 becomes set (one). If the I-bit in SREG and the INT0 bit in GIMSK are set (one), the MCU will jump to the interrupt vector at address \$002. The flag is cleared when the interrupt routine is executed. Alternatively, the flag can be cleared by writing a logical one to it.

- **Bits 5..0 – Res: Reserved Bits**

These bits are reserved bits in the AT43USB353M and always read as zero.



Timer/Counter Interrupt Mask Register – TIMSK

Bit	7	6	5	4	3	2	1	0	
\$39 (\$59)	TOIE1	OCIE1A	OCIE1NB	–	TICIE1	–	TOIE0	–	TIMSK
Read/Write	R/W	R/W	R/W	R	R/W	R	R/W	R	
Initial Value	0	0	0	0	0	0	0	0	

• Bit 7 – TOIE1: Timer/Counter1 Overflow Interrupt Enable

When the TOIE1 bit is set (one) and the I-bit in the Status Register is set (one), the Timer/Counter1 Overflow interrupt is enabled. The corresponding interrupt (at vector \$006) is executed if an overflow in Timer/Counter1 occurs, i.e., when the TOV1 bit is set in the Timer/Counter Interrupt Flag Register (TIFR).

• Bit 6 – OCIE1A: Timer/Counter1 Output CompareA Match Interrupt Enable

When the OCIE1A bit is set (one) and the I-bit in the Status Register is set (one), the Timer/Counter1 CompareA Match interrupt is enabled. The corresponding interrupt (at vector \$004) is executed if a CompareA match in Timer/Counter1 occurs, i.e., when the OCF1A bit is set in the TIFR.

• Bit 5 – OCIE1B: Timer/Counter1 Output CompareB Match Interrupt Enable

When the OCIE1B bit is set (one) and the I-bit in the Status Register is set (one), the Timer/Counter1 CompareB Match interrupt is enabled. The corresponding interrupt (at vector \$005) is executed if a CompareB match in Timer/Counter1 occurs, i.e., when the OCF1B bit is set in the TIFR.

• Bit 4 – Res: Reserved Bit

This bit is a reserved bit in the AT43USB353M and always reads zero.

• Bit 3 – TICIE1: Timer/Counter1 Input Capture Interrupt Enable

When the TICIE1 bit is set (one) and the I-bit in the Status Register is set (one), the Timer/Counter1 Input Capture Event Interrupt is enabled. The corresponding interrupt (at vector \$003) is executed if a capture-triggering event occurs on pin 31, ICP, i.e., when the ICF1 bit is set in the TIFR.

• Bit 2 – Res: Reserved Bit

This bit is a reserved bit in the AT43USB353M and always reads zero.

• Bit 1 – TOIE0: Timer/Counter0 Overflow Interrupt Enable

When the TOIE0 bit is set (one) and the I-bit in the Status Register is set (one), the Timer/Counter0 Overflow interrupt is enabled. The corresponding interrupt (at vector \$007) is executed if an overflow in Timer/Counter0 occurs, i.e., when the TOV0 bit is set in the TIFR.

• Bit 0 – Res: Reserved Bit

This bit is a reserved bit in the AT43USB353M and always reads zero.

Timer/Counter Interrupt Flag Register – TIFR

Bit	7	6	5	4	3	2	1	0	
\$38 (\$58)	TOV1	OCF1A	OCIFB	–	ICF1	–	TOV0	–	TIFR
Read/Write	R/W	R/W	R/W	R	R/W	R	R/W	R	
Initial Value	0	0	0	0	0	0	0	0	

- **Bit 7 – TOV1: Timer/Counter1 Overflow Flag**

The TOV1 is set (one) when an overflow occurs in Timer/Counter1. TOV1 is cleared by the hardware when executing the corresponding interrupt handling vector. Alternatively, TOV1 is cleared by writing a logic one to the flag. When the I-bit in SREG, and TOIE1 (Timer/Counter1 Overflow Interrupt Enable), and TOV1 are set (one), the Timer/Counter1 Overflow Interrupt is executed. In PWM mode, this bit is set when Timer/Counter1 changes counting direction at \$0000.

- **Bit 6 – OCF1A: Output Compare Flag 1A**

The OCF1A bit is set (one) when compare match occurs between the Timer/Counter1 and the data in OCR1A - Output Compare Register 1A. OCF1A is cleared by the hardware when executing the corresponding interrupt handling vector. Alternatively, OCF1A is cleared by writing a logic one to the flag. When the I-bit in SREG, and OCIE1A (Timer/Counter1 Compare match InterruptA Enable), and the OCF1A are set (one), the Timer/Counter1 Compare A match Interrupt is executed.

- **Bit 5 – OCF1B: Output Compare Flag 1B**

The OCF1B bit is set (one) when compare match occurs between the Timer/Counter1 and the data in OCR1B - Output Compare Register 1B. OCF1B is cleared by the hardware when executing the corresponding interrupt handling vector. Alternatively, OCF1B is cleared by writing a logic one to the flag. When the I-bit in SREG, and OCIE1B (Timer/Counter1 Compare match InterruptB Enable), and the OCF1B are set (one), the Timer/Counter1 Compare B match Interrupt is executed.

- **Bit 4 – Res: Reserved Bit**

This bit is a reserved bit in the AT43USB353M and always reads zero.

- **Bit 3 – ICF1: - Input Capture Flag 1**

The ICF1 bit is set (one) to flag an input capture event, indicating that the Timer/Counter1 value has been transferred to the input capture register - ICR1. ICF1 is cleared by the hardware when executing the corresponding interrupt handling vector. Alternatively, ICF1 is cleared by writing a logic one to the flag. When the SREG I-bit, and TICIE1 (Timer/Counter1 Input Capture Interrupt Enable), and ICF1 are set (one), the Timer/Counter1 Capture Interrupt is executed.

- **Bit 2 – Res: Reserved Bit**

This bit is a reserved bit in the AT43USB353M and always reads zero.

- **Bit 1 – TOV: Timer/Counter0 Overflow Flag**

The bit TOV0 is set (one) when an overflow occurs in Timer/Counter0. TOV0 is cleared by the hardware when executing the corresponding interrupt handling vector. Alternatively, TOV0 is cleared by writing a logic one to the flag. When the SREG I-bit, and TOIE0 (Timer/Counter0 Overflow Interrupt Enable), and TOV0 are set (one), the Timer/Counter0 Overflow interrupt is executed.

- **Bit 0 – Res: Reserved Bit**

This bit is a reserved bit in the AT43USB353M and always reads zero.

External Interrupts

The external interrupts are triggered by the INT0 and INT1 pins. Observe that, if enabled, the INT0/INT1 interrupt will trigger even if the INT0/INT1 pin is configured as an output. This feature provides a way of generating a software interrupt. The external interrupts can be triggered by a falling or rising edge or a low level. This is set up as indicated in the specification for the MCU Control Register (MCUCR) and the Interrupt Sense Control Register (ISCR). When INT0/INT1 is enabled and is configured as level triggered, the interrupt will trigger as long as the pin is held low. INT0/INT1 is set up as described in the specification for the MCU Control Register (MCUCR).

Interrupt Response Time

The interrupt execution response for all the enabled AVR interrupts is 4 clock cycles minimum. 4 clock cycles after the interrupt flag has been set, the program vector address for the actual interrupt handling routine is executed. During this 4 clock cycle period, the Program Counter (2 bytes) is pushed onto the Stack, and the Stack Pointer is decremented by 2. The vector is normally a jump to the interrupt routine, and this jump takes 3 clock cycles. If an interrupt occurs during execution of a multi-cycle instruction, this instruction is completed before the interrupt is served.

A return from an interrupt handling routine (same as for a subroutine call routine) takes 4 clock cycles. During these 4 clock cycles, the Program Counter (2 bytes) is popped back from the Stack, the Stack Pointer is incremented by 2, and the I flag in SREG is set. When the AVR exits from an interrupt, it will always return to the main program and execute one more instruction before any pending interrupt is served.

MCU Control Register – MCUCR

Bit	7	6	5	4	3	2	1	0	
\$35 (\$55)	-	-	SE	SM	ISC11	ISC10	ISC01	ISC00	MCUCR
Read/Write	R	R	R/W	R/W	R/W	R/W	R/W	R/W	
Initial Value	0	0	0	0	0	0	0	0	

- **Bit 7, 6 – Res: Reserved Bits**
- **Bit 5 – SE: Sleep Enable**

The SE bit must be set (1) to make the MCU enter the sleep mode when the SLEEP instruction is executed. To avoid the MCU entering the sleep mode, unless it is the programmer's purpose, it is recommended to set the Sleep Enable SE bit just before the execution of the SLEEP instruction.

- **Bit 4 – SM: Sleep Mode**

This bit selects between the two available sleep modes. When SM is cleared (zero), Idle Mode is selected as Sleep Mode. When SM is set (1), Power Down mode is selected as sleep mode. The AT43USB353M does not support the Idle Mode and SM should always be set to one when entering the Sleep Mode.

- **Bit 3, 2 – ISC11, ISC10: Interrupt Sense Control 1 Bit 1 and Bit 0**

The External Interrupt 1 is activated by the external pin INT1 if the SREG I-flag and the corresponding interrupt mask in the GIMSK is set. The level and edges on the external INT1 pin that activate the interrupt are defined in Table 10.

Table 9. INT1 Sense Control

ISC11	ISC10	Description
0	0	The low level of INT1 generates an interrupt request.
0	1	Reserved.
1	0	The falling edge of INT1 generates an interrupt request.
1	1	The rising edge of INT1 generates an interrupt request.

- **Bit 1, 0 – ISC01, ISC00: Interrupt Sense Control 0 bit 1 and bit 0**

The External Interrupt 0 is activated by the external pin INT0 if the SREG I-flag and the corresponding interrupt mask in the GIMSK is set. The level and edges on the external INT0 pin that activate the interrupt are defined in Table 10.

Table 10. INT0 Sense Control

ISC01	ISC00	Description
0	0	The low level of INT0 generates an interrupt request.
0	1	Reserved.
1	0	The falling edge of INT0 generates an interrupt request.
1	1	The rising edge of INT0 generates an interrupt request.

USB Interrupt Sources

The USB interrupts are described below.

Table 11. USB Interrupt Sources

Interrupt	Description
SOF Received	Whenever USB hardware decodes a valid Start of Frame. The frame number is stored in the two Frame Number Registers.
EOF2	Activated whenever the hub's frame timer reaches its EOF2 time point.
Function EP0 Interrupt	See "Control Transfers at Control End-point EP0" on page 58 for details.
Function EP1 Interrupt	For an OUT end-point it indicates that Function End-point 1 has received a valid OUT packet and that the data is in the FIFO. For an IN end-point it means that the end-point has received an IN token, sent out the data in the FIFO and received an ACK from the Host. The FIFO is now ready to be written by new data from the microcontroller.
Function EP2 Interrupt	For an OUT end-point it indicates that Function End-point 2 has received a valid OUT packet and that the data is in the FIFO. For an IN end-point it means that the end-point has received an IN token, sent out the data in the FIFO and received an ACK from the Host. The FIFO is now ready to be written by new data from the microcontroller.
Function EP3 Interrupt	For an OUT end-point it indicates that Function End-point 3 has received a valid OUT packet and that the data is in the FIFO. For an IN end-point it means that the end-point has received an IN token, sent out the data in the FIFO and received an ACK from the Host. The FIFO is now ready to be written by new data from the microcontroller.
Hub EP0 Interrupt	See "Control Transfers at Control End-point EP0" on page 58 for details.
FRWUP	USB hardware has received a embedded function remote wakeup request.
GLB SUSP	USB hardware has received global suspend signaling and is preparing to put the hub in the suspend mode. The microcontroller's firmware should place the embedded function in the suspend state.
RSM	USB hardware received resume signaling and is propagating the resume signaling. The microcontroller's firmware should take the embedded function out of the suspended state.
BUS RESET	USB hardware received a USB bus reset. This applies only in cases where a separation between USB bus reset and microcontroller reset is required. Be very careful when using this feature.

All interrupts have individual enable, status, and mask bits through the interrupt enable register and interrupt mask register. The Suspend and Resume interrupts are cleared by writing a 0 to the particular interrupt bit. All other interrupts are cleared when the microcontroller sets a bit in an interrupt acknowledge register.

USB End-point Interrupt Sources

An assertion or activation of one or more bits in the end-point's Control and Status Register triggers the end-point interrupts. These triggers are different for control and non-control end-points as described in Table 12. Please refer to the Control and Status Register for more information.

Table 12. USB End-point Interrupt Sources

Bit	End-point type
RX_OUT_PACKET	CONTROL, OUT
TX_COMPLETE	CONTROL, IN
STALL_SENT	CONTROL, IN
RX_SETUP	CONTROL

USB Interrupt Status Register – UISR

Bit	7	6	5	4	3	2	1	0	
\$1FF7	SOF INT	EOF2 INT	–	FE3 INT	HEP0 INT	FE2 INT	FE1 INT	FE0 INT	UISR
Read/Write	R	R	R	R	R	R	R	R	
Initial Value	0	0	0	0	0	0	0	0	

• **Bit 7 – SOF INT: Start of Frame Interrupt**

This bit is asserted after the USB hardware receives a valid SOF packet.

• **Bit 6 – EOF2 INT: EOF2 Interrupt**

This bit is asserted 10 clocks before the expected start of a frame.

• **Bit 5 – Res: Reserved Bit**

This bit is reserved and always reads as zero.

• **Bit 4 – FEP3 INT: Function End-point 3 Interrupt**

• **Bit 3 – HEP0 INT: Hub End-point 0 Interrupt**

• **Bit 2 – FEP2 INT: Function End-point 2 Interrupt**

• **Bit 1 – FEP1 INT: Function End-point 1 Interrupt**

• **Bit 0 – FEP0 INT: Function End-point 0 Interrupt**

The hub and function interrupt bits will be set by the hardware whenever the following bits in the corresponding end-point's Control and Status Register are modified by the USB hardware:

1. RX OUT Packet is set (control and OUT end-points)
2. TX Packet Ready is cleared AND TX Complete is set (control and IN end-points)
3. RX SETUP is set (control end-points only)
4. TX Complete is set



USB Interrupt Mask Register – UIMSKR

Bit	7	6	5	4	3	2	1	0	
\$1FF6	SOF IMSK	EOF2 IMSK	–	FEP3 IMSK	HEP0 IMSK	FEP2 IMSK	FEP1 IMSK	FEP0 IMSK	UIMSKR
Read/Write	R/W	R/W	R	R/W	R/W	R/W	R/W	R/W	
Initial Value	0	0	0	0	0	0	0	0	

- **Bit 7 – SOF IMSK: Start of Frame Interrupt Mask**

When the SOF IMSK bit is set (1), the Start of Frame Interrupt is masked.

- **Bit 6 – EOF2 IMSK: EOF2 Interrupt Mask**

When the EOF2 IMSK bit is set (1), the EOF2 Interrupt is masked.

- **Bit 5 – Res: Reserved bit**

This bit is reserved and always read as zero.

- **Bit 4 – FEP3 IMSK: Function End-point 3 Interrupt Mask**

When the FE3 IMSK bit is set (1), the Function End-point 3 Interrupt is masked.

- **Bit 3 – HEP0 IMSK: End-point 0 Interrupt Mask**

When the HEP0 IMSK bit is set (1), the Hub End-point 0 Interrupt is masked.

- **Bit 2 – FEP2 IMSK: End-point 2 Interrupt Mask**

When the FE2 IMSK bit is set (1), the Function End-point 2 Interrupt is masked.

- **Bit 1 – FEP1 IMSK: End-point 1 Interrupt Mask**

When the FE1 IMSK bit is set (1), the Function End-point 1 Interrupt is masked.

- **Bit 0 – FEP0 IMSK: End-point 0 Interrupt Mask**

When the FE0 IMSK bit is set (1), the Function End-point 0 Interrupt is masked.

USB Interrupt Acknowledge Register – UIAR

Bit	7	6	5	4	3	2	1	0	
\$1FF5	SOF INTACK	EOF2 INTACK	–	FEP3 INTACK	HEP0 INTACK	FEP2 IMSK	FEP1 INTACK	FEP0 INTACK	UIAR
Read/Write	W	W	R	W	W	W	W	W	
Initial Value	0	0	0	0	0	0	0	0	

- **Bit 7 – SOF INTACK: Start of Frame Interrupt Acknowledge**

The microcontroller firmware writes a 1 to this bit to clear the SOF INT bit.

- **Bit 6 – EOF2 INTACK: EOF2 Interrupt Acknowledge**

The microcontroller firmware writes a 1 to this bit to clear the EOF2 INT bit.

- **Bit 5 – Res: Reserved bit**

This bit is reserved and is always read as zero.

- **Bit 4 – FEP3 INTACK: Function End-point 3 Interrupt Acknowledge**

The microcontroller firmware writes a 1 to this bit to clear the FEP3 INT bit.

- **Bit 3 – HEP0 INTACK: Hub End-point 0 Interrupt Acknowledge**

The microcontroller firmware writes a 1 to this bit to clear the HEP0 INT bit.

- **Bit 2 – FEP2 INTACK: Function End-point 2 Interrupt Acknowledge**

The microcontroller firmware writes a 1 to this bit to clear the FEP2 bit.

- **Bit 1 – FEP1 INTACK: Function End-point 1 Interrupt Acknowledge**

The microcontroller firmware writes a 1 to this bit to clear the FEP1 bit.

- **Bit 0 – FEP0 INTACK: Function End-point 0 Interrupt Acknowledge**

The microcontroller firmware writes a 1 to this bit to clear the FEP0 INT bit.

USB Interrupt Enable Register – UIER

Bit	7	6	5	4	3	2	1	0	
\$1FF3	SOF IE	EOF2 IE	–	FEP3 IE	HEP0 IE	FEP2 IE	FEP1 IE	FEP0 IE	UIER
Read/Write	R/W	R/W	R	R/W	R/W	R/W	R/W	R/W	
Initial Value	0	0	0	0	0	0	0	0	

- **Bit 7 – SOF IE: Enable Start of Frame Interrupt**

When the SOF IE bit is set (1), the Start of Frame Interrupt is enabled.

- **Bit 6 – EOF2 IE: Enable EOF2 Interrupt**

When the EOF2 IE bit is set (1), the EOF2 Interrupt is enabled.

- **Bit 5 – Res: Reserved bit**

This bit is reserved and always read as zero.

- **Bit 4 – FEP3 IE: Enable Function End-point 3 Interrupt**

When the FE3 IE bit is set (1), the Function End-point 3 Interrupt is enabled.

- **Bit 3 – HEP0 IE: Enable End-point 0 Interrupt**

When the HEP0 IE bit is set (1), the Hub End-point 0 Interrupt is enabled.

- **Bit 2 – FEP2 IE: Enable End-point 2 Interrupt**

When the FE2 IE bit is set (1), the Function End-point 2 Interrupt is enabled.

- **Bit 1 – FEP1 IE: Enable End-point 1 Interrupt**

When the FE1 IE bit is set (1), the Function End-point 1 Interrupt is enabled.

- **Bit 0 – FEP0 IE: Enable End-point 0 Interrupt**

When the FE0 IE bit is set (1), the Function End-point 0 Interrupt is enabled.

Suspend/Resume Register – SPRSR

Bit	7	6	5	4	3	2	1	0	
\$1FFA	–	–	–	–	BUS INT	FRWUP	RSM	GLB SUSP	SPRSR
Read/Write	R	R	R	R	R/W	R	R	R	
Initial Value	0	0	0	0	0	0	0	0	

- **Bit 7..4 – Res: Reserved Bits**

These bits are reserved and are always read as zeros.

- **Bit 3 – BUS INT: USB Bus Interrupt**

When the USB reset separation feature is enabled (SPRSIE and SPRSMSK bits 3 are set to 1) the BUS INT bit is set when USB bus reset is detected by the USB hardware.

- **Bit 2 – FRWUP: Function Remote Wakeup**

The USB hardware sets this bit to signal that External Interrupt 1 is detected indicating remote wakeup. An interrupt is generated if the FRWUP IE bit of the SPRSIE register is set.

- **Bit 1 – RSM: Resume**

The USB hardware sets this bit when a USB resume signaling is detected at any of its port except Port 1. An interrupt is generated if the RSM IE bit of the SPRSIE register is set.

- **Bit 0 – GLB SUSP: Global Suspend**

The USB hardware sets this bit when a USB global suspend signaling is detected. An interrupt is generated if the GLBSUSP IE bit of the SPRSIE register is set.

Suspend/Resume Interrupt Enable Register – SPRSIE

Bit	7	6	5	4	3	2	1	0	
\$1FF9	–	–	–	–	BUS INT	FRWUP	RSM	GLB SUSP	SPRSIE
Read/Write	R	R	R	R	R/W	R	R	R	
Initial Value	0	0	0	0	0	0	0	0	

- **Bit 7..4 – Res: Reserved Bits**

These bits are reserved and are always read as zeros.

- **Bit 3 – BUS INT EN: USB Reset Interrupt Enable**

When the BUS INT EN bit is set, the USB and microcontroller resets are separated. A USB bus reset (SE0 for longer than 3 ms) will reset the USB hardware only and not the microcontroller. However, an interrupt to the microcontroller will be generated and bit 3 of SPRSR is set.

- **Bit 2 – FRWUP IE: Function Remote Wakeup Interrupt Enable**

Setting the FRWUP IE bit will initiate an interrupt whenever the FRWUP bit of SPRSR is set.

- **Bit 1 – RSM IE: Resume Interrupt Enable**

Setting the RSM IE bit will initiate an interrupt whenever the RSM bit of SPRSR is set.

- **Bit 0 – GLB SUSP IE: Global Suspend Interrupt Enable**

Setting the GLB SUSP IE bit will initiate an interrupt whenever the GLB SUSP bit of SPRSR is set.

Suspend/Resume Interrupt Mask Register – SPRSMSK

Bit	7	6	5	4	3	2	1	0	
\$1FF8	–	–	–	–	BUS INT MSK	FRWUP MSK	RSM	GLB SUSP	SPRSMSK
Read/Write	R	R	R	R	W	W	W	W	
Initial Value	0	0	0	0	0	0	0	0	

The bits of the Suspend/Resume Mask Register are used to make an interrupt caused by an event in the Suspend/Resume Register visible to the microcontroller. The Suspend/Resume Interrupt Enable Register bits enable the interrupt while the Suspend/Resume Interrupt Mask Register allows the microcontroller to control when it wants visibility to an interrupt. 1 = Enable Mask, 0 = Disable Mask.

- **Bit 7..4 – Res: Reserved Bits**

These bits are reserved and are always read as zeros.

- **Bit 3 – BUS INT MSK: USB Reset Interrupt Mask**

- **Bit 2 – FRWUP MSK: Function Remote Wakeup Interrupt Mask**

- **Bit 1 – RSM MSK: Resume Interrupt Mask**

- **Bit 0 – GLB SUSP MSK: Global Suspend Interrupt Enable**

AVR Register Set

Status Register and Stack Pointer

Status Register – SREG

Bit	7	6	5	4	3	2	1	0	
\$3F (\$5F)	I	T	H	S	V	N	Z	C	SREG
Read/Write	R/W	R/W	R/W	R/W	R/W	R/W	R/W	R/W	
Initial Value	0	0	0	0	0	0	0	0	

- **Bit 7 – I: Global Interrupt Enable**

The global interrupt enable bit must be set (one) for the interrupts to be enabled. The individual interrupt enable control is then performed in separate control registers. If the global interrupt enable bit is cleared (zero), none of the interrupts are enabled independent of the individual interrupt enable settings. The I-bit is cleared by the hardware after an interrupt has occurred, and is set by the RETI instruction to enable subsequent interrupts.

- **Bit 6 – T: Bit Copy Storage**

The bit copy instructions BLD (Bit Load) and BST (Bit Store) use the T bit as source and destination for the operated bit. A bit from a register in the register file can be copied into T by the BST instruction, and a bit in T can be copied into a bit in a register in the register file by the BLD instruction.

- **Bit 5 – H: Half Carry Flag**

The half carry flag H indicates a half carry in some arithmetic operations. See the Instruction Set Description for detailed information.

- **Bit 4 – S: Sign Bit, $S = N \oplus V$**

The S-bit is always an exclusive or between the negative flag N and the two's complement overflow flag V. See the Instruction Set Description for detailed information.

- **Bit 3 – V: Two's Complement Overflow Flag**

The two's complement overflow flag V supports two's complement arithmetics. See the Instruction Set Description for detailed information.

- **Bit 2 – N: Negative Flag**

The negative flag N indicates a negative result after the different arithmetic and logic operations. See the Instruction Set Description for detailed information.

- **Bit 1 – Z: Zero Flag**

The zero flag Z indicates a zero result after the different arithmetic and logic operations. See the Instruction Set Description for detailed information.

- **Bit 0 – C: Carry Flag**

The carry flag C indicates a carry in an arithmetic or logic operation. See the Instruction Set Description for detailed information.

Note that the status register is not automatically stored when entering an interrupt routine and restored when returning from an interrupt routine. This must be handled by software.

Stack Pointer Register – SP

Bit	15	14	13	12	11	10	9	8	
\$3E (\$5E)	I	T	H	S	V	N	Z	C	SPH
\$3D (\$5D)	SP7	SP6	SP5	SP4	SP3	SP2	SP1	SP0	SPL
	7	6	5	4	3	2	1	0	
Read/Write	R/W	R/W	R/W	R/W	R/W	R/W	R/W	R/W	
	R/W	R/W	R/W	R/W	R/W	R/W	R/W	R/W	
Initial Value	0	0	0	0	0	0	0	0	
	0	0	0	0	0	0	0	0	

The Stack Pointer points to the data SRAM stack area where the Subroutine and Interrupt Stacks are located. This Stack space in the data SRAM must be defined by the program before any subroutine calls are executed or interrupts are enabled. The stack pointer must be set to point above \$60. The Stack Pointer is decremented by one when data is pushed onto the Stack with the PUSH instruction, and it is decremented by two when an address is pushed onto the Stack with subroutine calls and interrupts. The Stack Pointer is incremented by one when data is popped from the Stack with the POP instruction and it is incremented by two when an address is popped from the Stack with return from subroutine RET or return from interrupt RETI.

Sleep Modes

To enter the sleep modes, the SE bit in MCUCR must be set (one) and a SLEEP instruction must be executed. If an enabled interrupt occurs while the MCU is in a sleep mode, the MCU awakes, executes the interrupt routine, and resumes execution from the instruction following SLEEP. The contents of the register file, SRAM and I/O memory are unaltered. If a reset occurs during sleep mode, the MCU wakes up and executes from the Reset vector.

Power Down Mode

When the SM bit is set (one), the SLEEP instruction forces the MCU into the Power Down Mode. In this mode, the external oscillator is stopped, while the external interrupts continue operating. Only an external reset, an external level interrupt on INT0 or INT1, can wake up the MCU.

Note that when a level triggered interrupt is used for wake-up from power down, the low level must be held for a time longer than the reset delay time-out period t_{TOUT} . Otherwise, the MCU will fail to wake up.

Timer/Counters

The AT43USB353M provides two general-purpose Timer/Counters - one 8-bit T/C and one 16-bit T/C. The Timer/Counters have individual prescaling selection from the same 10-bit prescaling timer. The Timer/Counters of the AT43USB353M do not have external trigger inputs like those of the AT43USB355.

Timer/Counter Prescaler

The four different prescaled selections are: CK/8, CK/64, CK/256 and CK/1024 where CK is the oscillator clock. For the two Timer/Counters, added selections as CK, external source and stop, can be selected as clock sources.

Note: When the AT43USB353M MCU is operating at 24 MHz, the MCU clock frequency is halved before it is used in the Timer/Counter Prescaler circuit. The source clock for the Timer/Counter is always 12 MHz.

Figure 9. Timer/Counter Prescaler

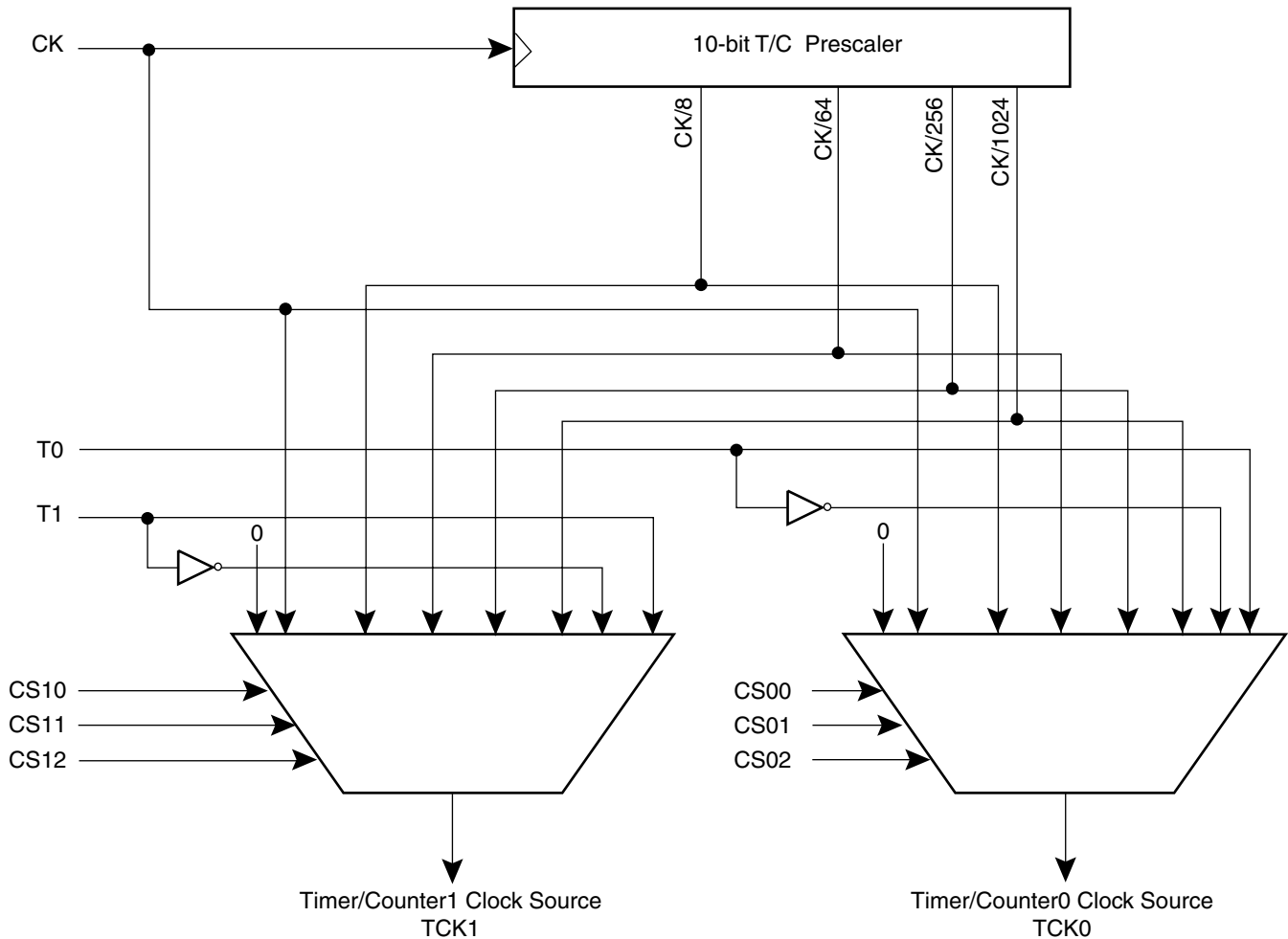

**8-bit
Timer/Counter0**

The 8-bit Timer/Counter0 clock source is prescaled from CK, 12 MHz. In addition it can be stopped as described in the specification for the Timer/Counter0 Control Register (TCCR0). The overflow status flag is found in the Timer/Counter Interrupt Flag Register (TIFR). Control signals are found in the Timer/Counter0 Control Register (TCCR0). The interrupt enable/disable settings for Timer/Counter0 are found in the Timer/Counter Interrupt Mask Register - TIMSK.

The 8-bit Timer/Counter0 features both a high resolution and a high accuracy usage with the lower prescaling opportunities. Similarly, the high prescaling opportunities make the Timer/Counter0 useful for lower speed functions or exact timing functions with infrequent actions.

Figure 10. Timer/Counter0 Block Diagram

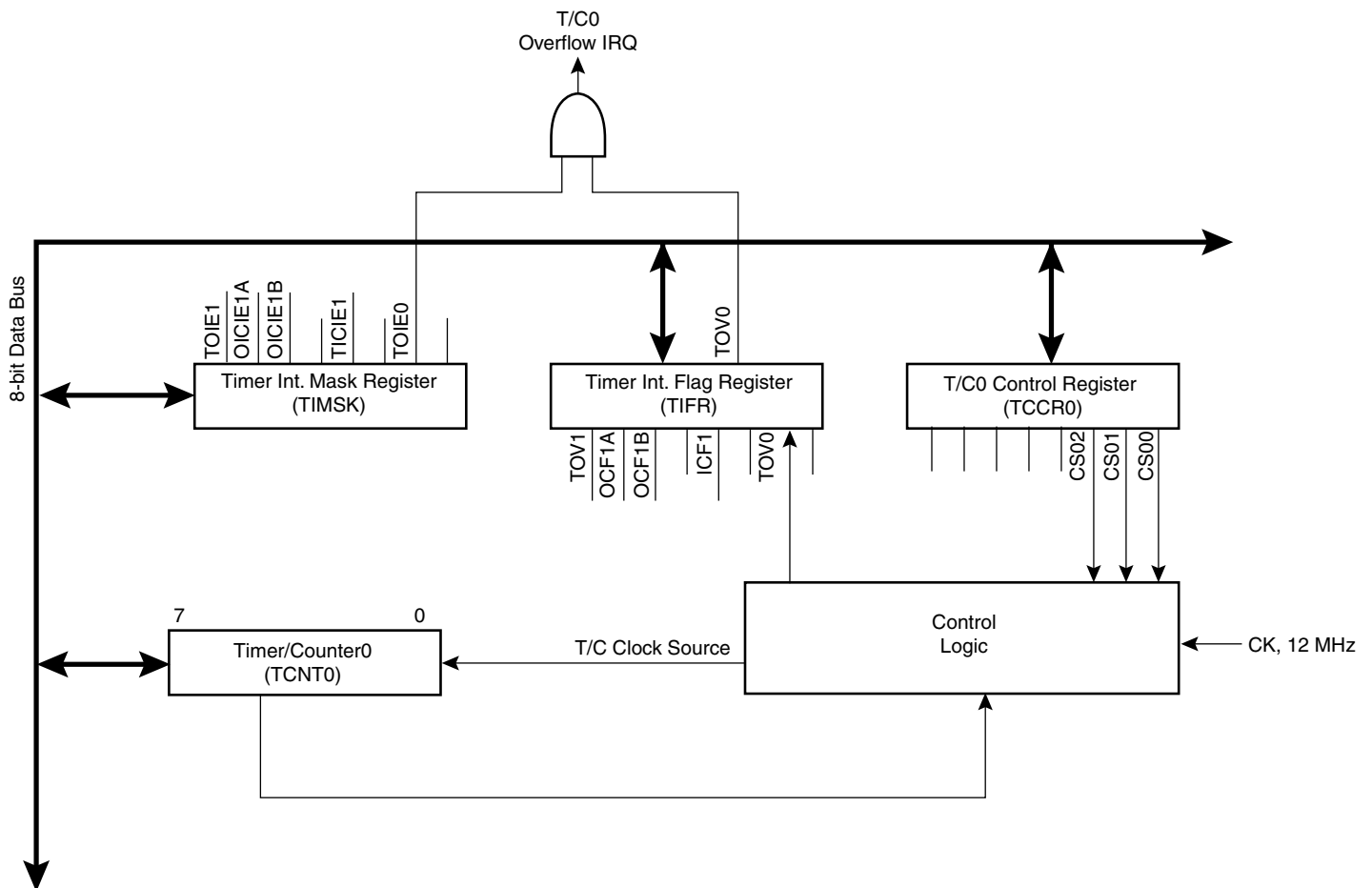

Timer/Counter0 Control Register – TCCR0

Bit	7	6	5	4	3	2	1	0	
\$33 (\$53)	–	–	–	–	–	CS02	CS01	CS00	TCCR0
Read/Write	R	R	R	R	R	R/W	R/W	R/W	
Initial Value	0	0	0	0	0	0	0	0	

- **Bits 7..3 – Res: Reserved Bits**

These bits are reserved bits in the AT43USB355 and always read as zero.

- **Bits 2, 1, 0 – CS02, CS01, CS00: Clock Select0, bit 2, 1 and 0**

The Clock Select0 bits 2, 1 and 0 define the prescaling source of Timer/Counter0.

Table 13. 12 MHz Clock Prescale Select

CS02	CS01	CS00	Description
0	0	0	Stop, the Timer/Counter0 is stopped
0	0	1	CK
0	1	0	CK/8
0	1	1	CK/64
1	0	0	CK/256
1	0	1	CK/1024
1	1	0	External Pin T0, falling edge
1	1	1	External Pin T0, rising edge

The Stop condition provides a Timer Enable/Disable function. The CK down divided modes are scaled directly from the CK 12 MHz clock.

Timer/Counter0 – TCNT0

Bit	7	6	5	4	3	2	1	0	
\$32 (\$52)	MSB	–	–	–	–	–	–	LSB	TCNT0
Read/Write	R/W	R/W	R/W	R/W	R/W	R/W	R/W	R/W	
Initial Value	0	0	0	0	0	0	0	0	

The Timer/Counter0 is realized as an up-counter with read and write access. If the Timer/Counter0 is written and a clock source is present, the Timer/Counter0 continues counting in the clock cycle following the write operation.

16-bit Timer/Counter1

Figure 11. Timer/Counter1 Block Diagram

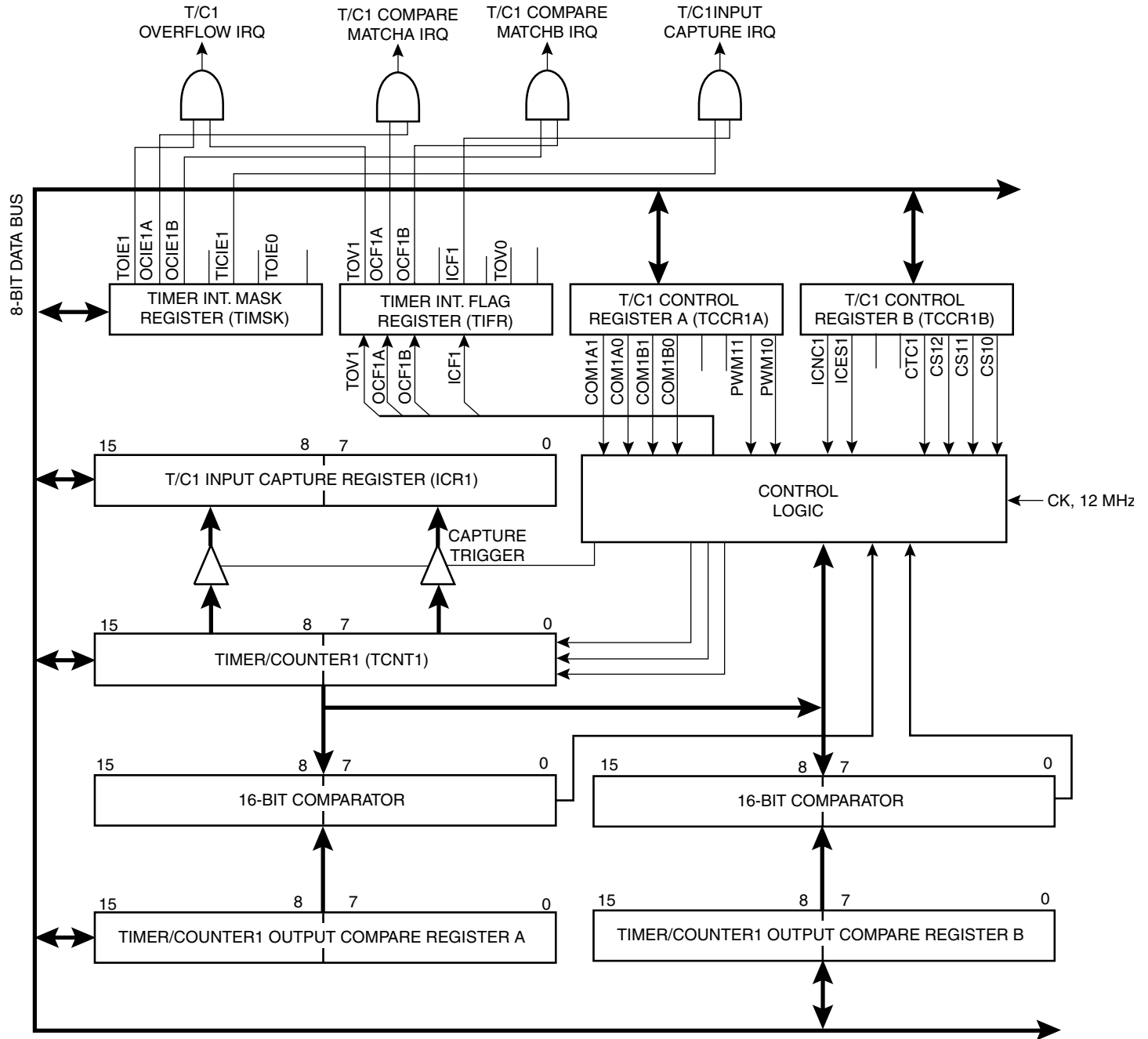

16-bit Timer/Counter1 Operation

The 16-bit Timer/Counter1 clock source is prescaled from CK, 12 MHz. In addition, it can be stopped as described in the specification for the Timer/Counter1 Control Registers (TCCR1A and TCCR1B). The different status flags (overflow, compare match and capture event) are found in the Timer/Counter Interrupt Flag Register (TIFR). Control signals are found in the Timer/Counter1 Control Registers (TCCR1A and TCCR1B). The interrupt enable/disable settings for Timer/Counter1 are found in the Timer/Counter Interrupt Mask Register (TIMSK).

The 16-bit Timer/Counter1 features both a high resolution and a high accuracy usage with the lower prescaling opportunities. Similarly, the high prescaling opportunities makes the Timer/Counter1 useful for lower speed functions or exact timing functions with infrequent actions.

The Timer/Counter1 supports two Output Compare functions using the Output Compare Register 1 A and B (OCR1A and OCR1B) as the data sources to be compared to the Timer/Counter1 contents. The Output Compare functions include optional clearing of the counter on compareA match, and actions on the Output Compare pins on both compare matches.

Timer/Counter1 can also be used as a 8-, 9- or 10-bit Pulse With Modulator. In this mode the counter and the OCR1A/OCR1B registers serve as a dual glitch-free stand-alone PWM with centered pulses.

The Input Capture function of Timer/Counter1 provides a capture of the Timer/Counter1 contents to the Input Capture Register - ICR1, triggered by an external event on the Input Capture Pin (ICP/PF3). The actual capture event settings are defined by the Timer/Counter1 Control Register (TCCR1B). The AT43USB353M has no comparator and the mux control signal, ACO, is permanently set so that the ICP input is routed to the noise canceler. In the AT43USB353M, the ICP function is shared with port D pin, PD4.

If the noise canceler function is enabled, the actual trigger condition for the capture event is monitored over 4 samples, and all 4 must be equal to activate the capture flag.

Figure 12. ICP Pin Schematic Diagram

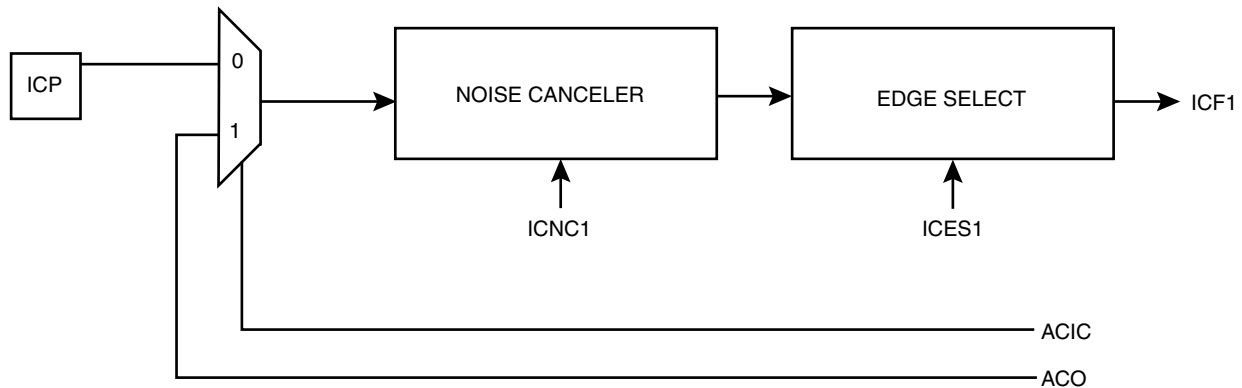

ACIC: COMPARATOR IC ENABLE
ACC0: COMPARATOR OUTPUT

Timer/Counter1 Control Register A – TCCR1A

Bit	7	6	5	4	3	2	1	0	
\$2F (\$4F)	COM1A1	COM1A0	COM1B1	COM1B0	–	–	PWM11	PWM10	TCCR1A
Read/Write	R/W	R/W	R/W	R/W	R	R	R/W	R/W	
Initial Value	0	0	0	0	0	0	0	0	

- **Bits 7, 6 – COM1A1, COM1A0: Compare Output Mode1A, Bits 1 and 0**

The COM1A1 and COM1A0 control bits determine any output pin action following a compare match in Timer/Counter1. Any output pin actions affect pin OC1A (Output CompareA) pin 1. This is an alternative function to an I/O port and the corresponding direction control bit must be set (one) to control the output pin. The control configuration is shown in Table 14.

- **Bits 5, 4 – COM1B1, COM1B0: Compare Output Mode1B, Bits 1 and 0**

The COM1B1 and COM1B0 control bits determine any output pin action following a compare match in Timer/Counter1. Any output pin actions affect pin OC1B (Output CompareB). The following control configuration is given:

Table 14. Compare 1 Mode Select⁽²⁾

COM1X1	COM1X0	Description
0	0	Timer/Counter1 disconnected from output pin OC1X. ⁽¹⁾
0	1	Toggle the OC1X output line. ⁽¹⁾
1	0	Clear the OC1X output line (to zero). ⁽¹⁾
1	1	Set the OC1X output line (to one). ⁽¹⁾

Note: 1. X = A or B

2. In PWM mode, these bits have a different function. Refer to Table 18 for a detailed description.

- **Bits 3..2 – Res: Reserved Bits**

These bits are reserved bits in the AT43USB353M and always read zero.

- **Bits 1..0 – PWM11, PWM10: Pulse Width Modulator Select Bits 1 and 0**

These bits select PWM operation of Timer/Counter1 as specified in Table 15.

Table 15. PWM Mode Select

PWM11	PWM10	Description
0	0	PWM operation of Timer/Counter1 is disabled.
0	1	Timer/Counter1 is an 8-bit PWM.
1	0	Timer/Counter1 is a 9-bit PWM.
1	1	Timer/Counter1 is a 10-bit PWM.

Timer/Counter1 Control Register B – TCCR1B

Bit	7	6	5	4	3	2	1	0	
\$2E (\$4E)	ICNC1	ICES1	–	–	CTC1	CS12	CS11	CS10	TCCR1B
Read/Write	R/W	R/W	R/W	R/W	R	R	R/W	R/W	
Initial Value	0	0	0	0	0	0	0	0	

- **Bit 7 – ICNC1: Input Capture1 Noise Canceler (4 CKs)**

When the ICNC1 bit is cleared (zero), the input capture trigger noise canceler function is disabled. The input capture is triggered at the first rising/falling edge sampled on the ICP (input capture pin) as specified. When the ICNC1 bit is set (one), four successive samples are measured on the ICP and all samples must be high/low according to the input capture trigger specification in the ICES1 bit. The actual sampling frequency is the 12 MHz system clock frequency.

- **Bit 6 – ICES1: Input Capture1 Edge Select**

While the ICES1 bit is cleared (zero), the Timer/Counter1 contents are transferred to the Input Capture Register (ICR1) on the falling edge of the ICP. While the ICES1 bit is set (one), the Timer/Counter1 contents are transferred to the ICR1 on the rising edge of the ICP.

- **Bits 5, 4 – Res: Reserved Bits**

These bits are reserved bits in the AT43USB353M and always read zero.

- **Bit 3 – CTC1: Clear Timer/Counter1 on Compare Match**

When the CTC1 control bit is set (one), the Timer/Counter1 is reset to \$0000 in the clock cycle after a compareA match. If the CTC1 control bit is cleared, Timer/Counter1 continues counting and is unaffected by a compare match. Since the compare match is detected in the CPU clock cycle following the match, this function will behave differently when a prescaling higher than 1 is used for the timer. When a prescaling of 1 is used, and the compareA register is set to C, the timer will count as follows if CTC1 is set:

... | C-2 | C-1 | C | 0 | 1 | ...

When the prescaler is set to divide by 8, the timer will count like this:

... | C-2, C-2, C-2, C-2, C-2, C-2, C-2, C-2 | C-1, C-1, C-1, C-1, C-1, C-1, C-1, C-1 | C, 0, 0, 0, 0, 0, 0, 0 | ...

In PWM mode, this bit has no effect.

- **Bits 2, 1, 0 – CS12, CS11, CS10: Clock Select1, Bit 2, 1 and 0**

The Clock Select1 bits 2, 1 and 0 define the prescaling source of Timer/Counter1.

Table 16. Clock 1 Prescale Select

CS12	CS11	CS10	Description
0	0	0	Stop, the Timer/Counter1 is stopped.
0	0	1	CK
0	1	0	CK/8
0	1	1	CK/64
1	0	0	CK/256
1	0	1	CK/1024
1	1	0	External Pin T1, falling edge
1	1	1	External Pin T1, rising edge

The Stop condition provides a Timer Enable/Disable function. The CK down divided modes are scaled directly from the 12 MHz input clock.

Timer/Counter1 – TCNT1H and TCNT1L

Bit	15	14	13	12	11	10	9	8	
\$2D (\$4D)	MSB	–	–	–	–	–	–	–	TCNT1H
\$2C (\$4C)	–	–	–	–	–	–	–	LSB	TCNT1L
	7	6	5	4	3	2	1	0	
Read/Write	R/W	R/W	R/W	R/W	R/W	R/W	R/W	R/W	
	R/W	R/W	R/W	R/W	R/W	R/W	R/W	R/W	
Initial Value	0	0	0	0	0	0	0	0	
	0	0	0	0	0	0	0	0	

This 16-bit register contains the prescaled value of the 16-bit Timer/Counter1. To ensure that both the high and low bytes are read and written simultaneously when the CPU accesses these registers, the access is performed using an 8-bit temporary register (TEMP). This temporary register is also used when accessing OCR1A, OCR1B and ICR1. If the main program and also interrupt routines perform access to registers using TEMP, interrupts must be disabled during access from the main program and from interrupt routines if interrupts are allowed from within interrupt routines.

- **TCNT1 Timer/Counter1 Write:**

When the CPU writes to the high byte TCNT1H, the written data is placed in the TEMP register. Next, when the CPU writes the low byte TCNT1L, this byte of data is combined with the byte data in the TEMP register, and all 16 bits are written to the TCNT1 Timer/Counter1 register simultaneously. Consequently, the high byte TCNT1H must be accessed first for a full 16-bit register write operation.

- **TCNT1 Timer/Counter1 Read:**

When the CPU reads the low byte TCNT1L, the data of the low byte TCNT1L is sent to the CPU and the data of the high byte TCNT1H is placed in the TEMP register. When the CPU reads the data in the high byte TCNT1H, the CPU receives the data in the TEMP register. Consequently, the low byte TCNT1L must be accessed first for a full 16-bit register read operation.

The Timer/Counter1 is realized as an up or up/down (in PWM mode) counter with read and write access. If Timer/Counter1 is written to and a clock source is selected, the Timer/Counter1 continues counting in the timer clock cycle after it is preset with the written value.

Timer/Counter1 Output Compare Register – OCR1AH and OCR1AL

Bit	15	14	13	12	11	10	9	8	
\$2B (\$4B)	MSB	–	–	–	–	–	–	–	OCR1AH
\$2A (\$4A)	–	–	–	–	–	–	–	LSB	OCR1AL
	7	6	5	4	3	2	1	0	
Read/Write	R/W	R/W	R/W	R/W	R/W	R/W	R/W	R/W	
	R/W	R/W	R/W	R/W	R/W	R/W	R/W	R/W	
Initial Value	0	0	0	0	0	0	0	0	
	0	0	0	0	0	0	0	0	

Timer/Counter1 Output Compare Register – OCR1BH and OCR1BL

Bit	15	14	13	12	11	10	9	8	
\$29 (\$49)	MSB	–	–	–	–	–	–	–	OCR1BH
\$28 (\$48)	–	–	–	–	–	–	–	LSB	OCR1BL
	7	6	5	4	3	2	1	0	
Read/Write	R/W	R/W	R/W	R/W	R/W	R/W	R/W	R/W	
	R/W	R/W	R/W	R/W	R/W	R/W	R/W	R/W	
Initial Value	0	0	0	0	0	0	0	0	
	0	0	0	0	0	0	0	0	

The output compare registers are 16-bit read/write registers.

The Timer/Counter1 Output Compare Registers contain the data to be continuously compared with Timer/Counter1. Actions on compare matches are specified in the Timer/Counter1 Control and Status register. A compare match does only occur if Timer/Counter1 counts to the OCR value. A software write that sets TCNT1 and OCR1A or OCR1B to the same value does not generate a compare match.

A compare match will set the compare interrupt flag in the CPU clock cycle following the compare event.

Since the Output Compare Registers OCR1A and OCR1B are 16-bit registers, a temporary register TEMP is used when OCR1A/B are written to ensure that both bytes are updated simultaneously. When the CPU writes the high byte, OCR1AH or OCR1BH, the data is temporarily stored in the TEMP register. When the CPU writes the low byte, OCR1AL or OCR1BL, the TEMP register is simultaneously written to OCR1AH or OCR1BH. Consequently, the high byte OCR1AH or OCR1BH must be written first for a full 16-bit register write operation.

The TEMP register is also used when accessing TCNT1, and ICR1. If the main program and also interrupt routines perform access to registers using TEMP, interrupts must be disabled during access from the main program and from interrupt routines if interrupts are allowed from within interrupt routines.

Timer/Counter1 Input Capture Register – ICR1H and ICR1L

Bit	15	14	13	12	11	10	9	8	
\$25 (\$45)	MSB	–	–	–	–	–	–	–	ICR1H
\$24 (\$44)	–	–	–	–	–	–	–	LSB	ICR1L
	7	6	5	4	3	2	1	0	
Read/Write	R	R	R	R	R	R	R	R	
	R	R	R	R	R	R	R	R	
Initial Value	0	0	0	0	0	0	0	0	
	0	0	0	0	0	0	0	0	

The input capture register is a 16-bit read-only register.

When the rising or falling edge (according to the input capture edge setting - ICES1) of the signal at the input capture pin (ICP) is detected, the current value of the Timer/Counter1 is transferred to the Input Capture Register (ICR1). At the same time, the Input Capture Flag (ICF1) is set (one).

Since the ICR1 is a 16-bit register, a temporary register TEMP is used when ICR1 is read to ensure that both bytes are read simultaneously. When the CPU reads the low byte ICR1L, the data is sent to the CPU and the data of the high byte ICR1H is placed in the TEMP register. When the CPU reads the data in the high byte ICR1H, the CPU receives the data in the TEMP register. Consequently, the low byte ICR1L must be accessed first for a full 16-bit register read operation.

The TEMP register is also used when accessing TCNT1, OCR1A and OCR1B. If the main program and also interrupt routines perform access to registers using TEMP, interrupts must be disabled during access from the main program and from interrupt routines, if interrupts are allowed from within interrupt routines.

Timer/Counter1 In PWM Mode

When the PWM mode is selected, Timer/Counter1, the Output Compare Register1A (OCR1A) and the Output Compare Register1B (OCR1B) form a dual 8-, 9- or 10-bit, free-running, glitch-free and phase correct PWM with outputs on the PD5 (OC1A) and OC1B pins. Timer/Counter1 acts as an up/down counter, counting up from \$0000 to TOP (see Table 17), where it turns and counts down again to zero before the cycle is repeated. When the counter value matches the contents of the 10 least significant bits of OCR1A or OCR1B, the PD5(OC1A)/OC1B pins are set or cleared according to the settings of the COM1A1/COM1A0 or COM1B1/COM1B0 bits in the Timer/Counter1 Control Register TCCR1A. Refer to Table 18 for details.

Table 17. Timer TOP Values and PWM Frequency

PWM Resolution	Timer TOP value	Frequency
8-bit	\$00FF (255)	$f_{TCK1}/510$
9-bit	\$01FF (511)	$f_{TCK1}/1022$
10-bit	\$03FF(1023)	$f_{TCK1}/2046$

Table 18. Compare1 Mode Select in PWM Mode

COM1X1	COM1X0	Effect on OCX1
0	0	Not connected
0	1	Not connected
1	0	Cleared on compare match, up-counting. Set on compare match, down-counting (non-inverted PWM).
1	1	Cleared on compare match, down-counting. Set on compare match, up-counting (inverted PWM).

Note: X = A or B

Note that in the PWM mode, the 10 least significant OCR1A/OCR1B bits, when written, are transferred to a temporary location. They are latched when Timer/Counter1 reaches the value TOP. This prevents the occurrence of odd-length PWM pulses (glitches) in the event of an unsynchronized OCR1A/OCR1B write. See Figure 13 for an example.

Figure 13. Effects on Unsynchronized OCR1 Latching

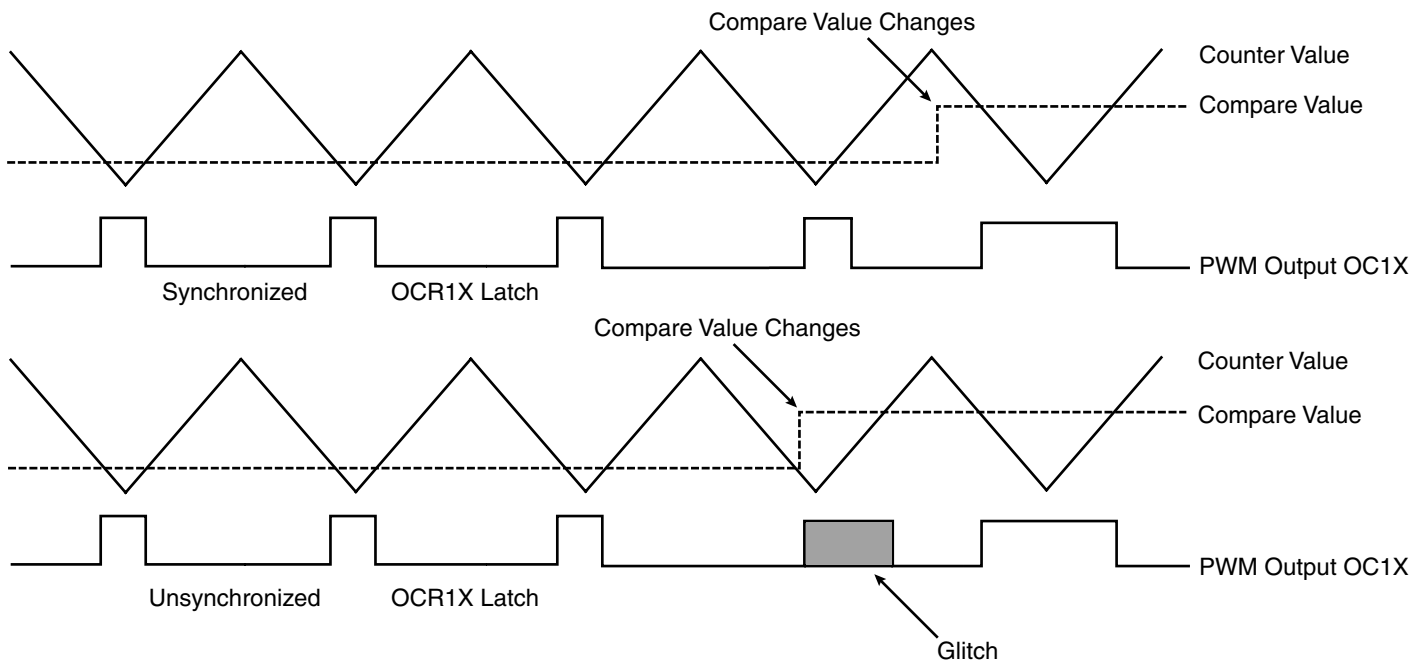

Note: X = A or B

During the time between the write and the latch operation, a read from OCR1A or OCR1B will read the contents of the temporary location. This means that the most recently written value always will read out of OCR1A/B

When the OCR1 contains \$0000 or TOP, the output OC1A/OC1B is updated to low or high on the next compare match, according to the settings of COM1A1/COM1A0 or COM1B1/COM1B0. This is shown in Table 19.

Note: If the compare register contains the TOP value and the prescaler is not in use (CS12..CS10 = 001), the PWM output will not produce any pulse at all, because up-counting and down-counting values are reached simultaneously. When the prescaler is in use (CS12..CS10 = 001 or 000), the PWM output goes active when the counter reaches the TOP

value, but the down-counting compare match is not interpreted to be reached before the next time the counter reaches the TOP value, making a one-period PWM pulse.

Table 19. PWM Outputs OCR1X = \$0000 or Top

COM1X1	COM1X0	OCR1X	Output OC1X
1	0	\$0000	L
1	0	TOP	H
1	1	\$0000	H
1	1	TOP	L

Note: X = A or B

In PWM mode, the Timer Overflow Flag1, TOV1, is set when the counter advances from \$0000. Timer Overflow Interrupt1 operates exactly as in normal Timer/Counter mode, i.e. it is executed when TOV1 is set provided that Timer Overflow Interrupt1 and global interrupts are enabled. This also applies to the Timer Output Compare1 flags and interrupts.

Watchdog Timer

The Watchdog Timer is clocked from a 1 MHz clock derived from the 6 MHz on chip oscillator. By controlling the Watchdog Timer prescaler, the Watchdog reset interval can be adjusted, see Table 20 for a detailed description. The WDR (Watchdog Reset) instruction resets the Watchdog Timer. Eight different clock cycle periods can be selected to determine the reset period. If the reset period expires without another Watchdog reset, the AT43USB355 resets and executes from the reset vector.

To prevent unintentional disabling of the watchdog, a special turn-off sequence must be followed when the watchdog is disabled. Refer to the description of the Watchdog Timer Control Register for details.

Figure 14. Watchdog Timer

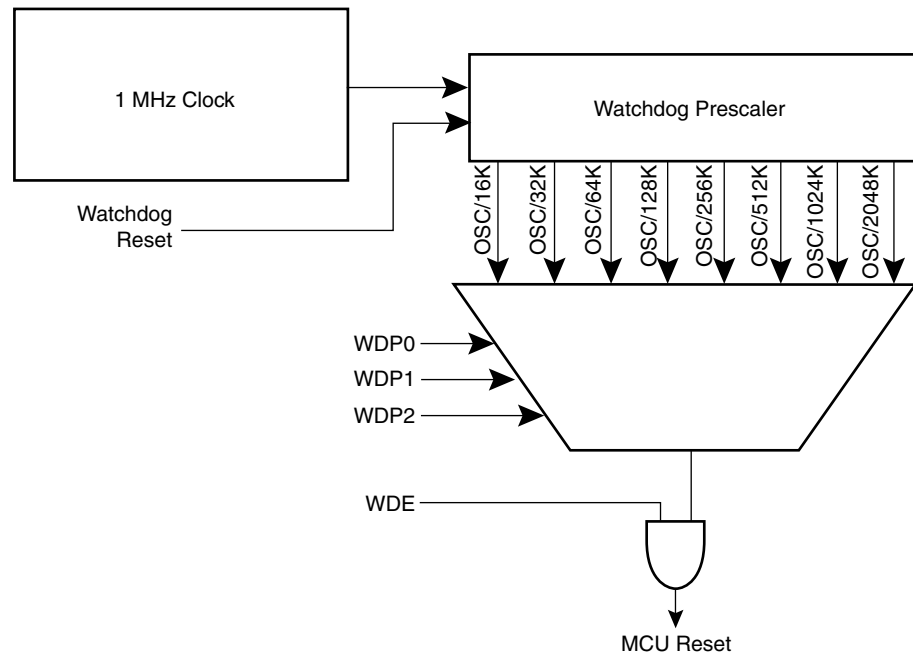

Watchdog Timer Control Register – WDTCR

Bit	7	6	5	4	3	2	1	0	
\$21 (\$41)	–	–	–	WDTOE	WDE	WDP2	WDP1	WDP0	WDTCR
Read/Write	R	R	R	R/W	R/W	R/W	R/W	R/W	
Initial Value	0	0	0	0	0	0	0	0	

- **Bits 7..5 – Res: Reserved Bits**

These bits are reserved bits in the AT43USB355 and will always read as zero.

- **Bit 4 – WDTOE: Watch Dog Turn-Off Enable**

This bit must be set (one) when the WDE bit is cleared. Otherwise, the watchdog will not be disabled. Once set, the hardware will clear this bit to zero after four clock cycles. Refer to the description of the WDE bit for a watchdog disable procedure.

- **Bit 3 – WDE: Watch Dog Enable**

When the WDE is set (one) the Watchdog Timer is enabled, and if the WDE is cleared (zero) the Watchdog Timer function is disabled. WDE can only be cleared if the WDTOE bit is set (one). To disable an enabled watchdog timer, the following procedure must be followed:

1. In the same operation, write a logical one to WDTOE and WDE. A logical one must be written to WDE even though it is set to one before the disable operation starts.
2. Within the next four clock cycles, write a logical 0 to WDE. This disables the watchdog.

- **Bits 2..0 – WDP2, WDP1, WDP0: Watch Dog Timer Prescaler 2, 1 and 0**

The WDP2, WDP1 and WDP0 bits determine the Watchdog Timer prescaling when the Watchdog Timer is enabled. The different prescaling values and their corresponding Time-out Periods are shown in Table 20.

Table 20. Watchdog Timer Prescale Select

WDP2	WDP1	WDP0	Number of WDT Oscillator cycles	Time-out
0	0	0	8K cycles	8.2 ms
0	0	1	16K cycles	16.4 ms
0	1	0	32K cycles	33.8 ms
0	1	1	64K cycles	65.6 ms
1	0	0	128K cycles	0.131 s
1	0	1	256K cycles	0.262 s
1	1	0	512K cycles	0.524 s
1	1	1	1,024K cycles	1.048 s

Note: The WDR (Watchdog Reset) instruction should always be executed before the Watchdog Timer is enabled. This ensures that the reset period will be in accordance with the Watchdog Timer prescale settings. If the Watchdog Timer is enabled without reset, the watchdog timer may not start to count from zero. To avoid unintentional MCU reset, the Watchdog Timer should be disabled or reset before changing the Watchdog Timer Prescale Select.

Analog-to-digital Converter

Feature list:

- 10-bit Resolution
- 4 LSB Integral Non-linearity
- ± 2 LSB Absolute Accuracy
- 12 – 768 μ s Conversion Time
- Up to 83 kSPS at Maximum Resolution
- 12 Multiplexed Input Channels
- Rail-to-rail Input Range
- Free Running or Single Conversion Mode
- Interrupt on ADC Conversion Complete

The AT43USB353M features a 10-bit successive approximation ADC. The ADC is connected to a 12-channel Analog Multiplexer to pins AD0 – AD11. The ADC contains a Sample and Hold Amplifier that ensures that the input voltage to the ADC is held at a constant level during conversion. A block diagram of the ADC is shown in Figure 15.

The reference voltage of the ADC is internally connected to the CEXTA voltage regulator.

Figure 15. Analog-to-digital Converter Block Schematic

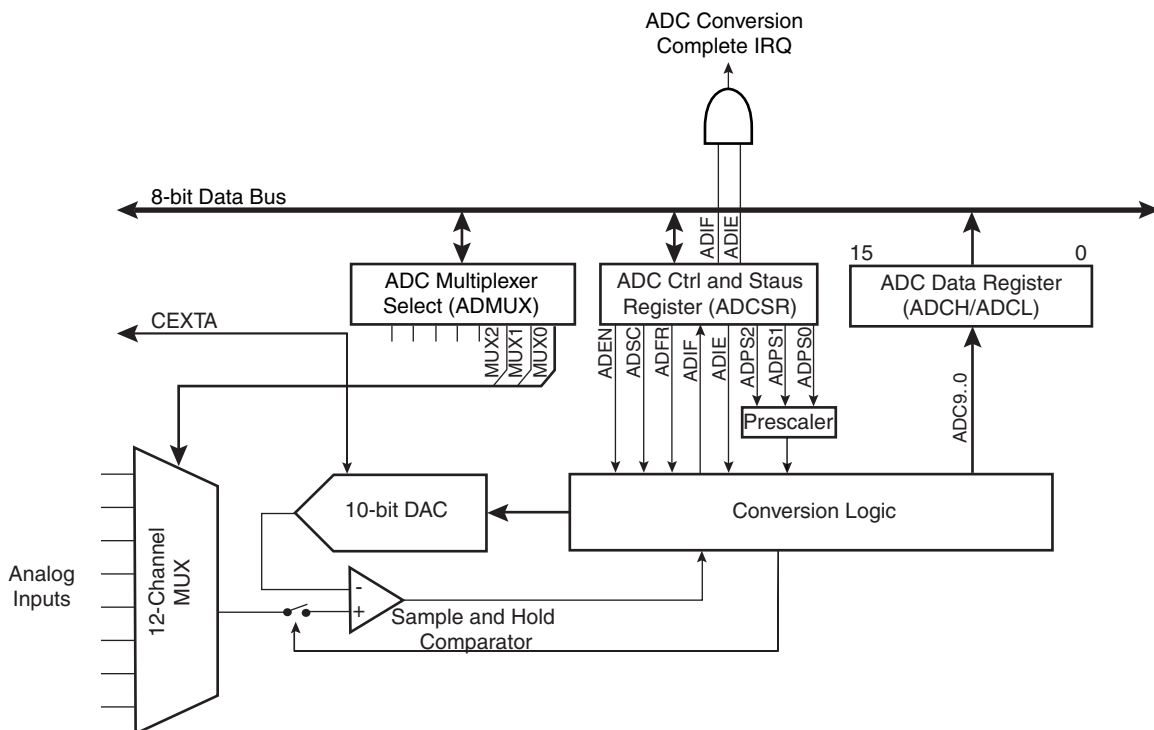

Operation

The ADC converts an analog input voltage to a 10-bit digital value through successive approximation. The minimum value represents V_{SSA} and the maximum value represents the voltage on the V_{REF} pin minus one LSB. The analog input channel is selected by writing to the MUX bits in ADMUX. Any of the twelve ADC input pins ADC11 – 0 can be selected as single-ended inputs to the ADC.

The ADC can operate in two modes – Single Conversion and Free Running. In Single Conversion Mode, each conversion will have to be initiated by the user. In Free Running Mode, the ADC is constantly sampling and updating the ADC Data Register. The ADFR bit in ADCSR selects between the two available modes.

The ADC is enabled by setting the ADC Enable bit, ADEN in ADCSR. Input channel selections will not go into effect until ADEN is set. The ADC does not consume power when ADEN is cleared, so it is recommended to switch off the ADC before entering power-saving sleep modes.

A conversion is started by writing a logical “1” to the ADC Start Conversion bit, ADSC. This bit stays high as long as the conversion is in progress and will be set to zero by the hardware when the conversion is completed. If a different data channel is selected while a conversion is in progress, the ADC will finish the current conversion before performing the channel change.

The ADC generates a 10-bit result, which is presented in the ADC data register, ADCH and ADCL. When reading data, ADCL must be read first, then ADCH, to ensure that the content of the data register belongs to the same conversion. Once ADCL is read, ADC access to data register is blocked. This means that if ADCL has been read and a conversion completes before ADCH is read, neither register is updated and the result from the conversion is lost. Then ADCH is read, ADC access to the ADCH and ADCL register is re enabled.

The ADC has its own interrupt that can be triggered when a conversion completes. When ADC access to the data registers is prohibited between reading of ADCH and ADCL, the interrupt will trigger even if the result is lost.

Figure 16. ADC Prescaler

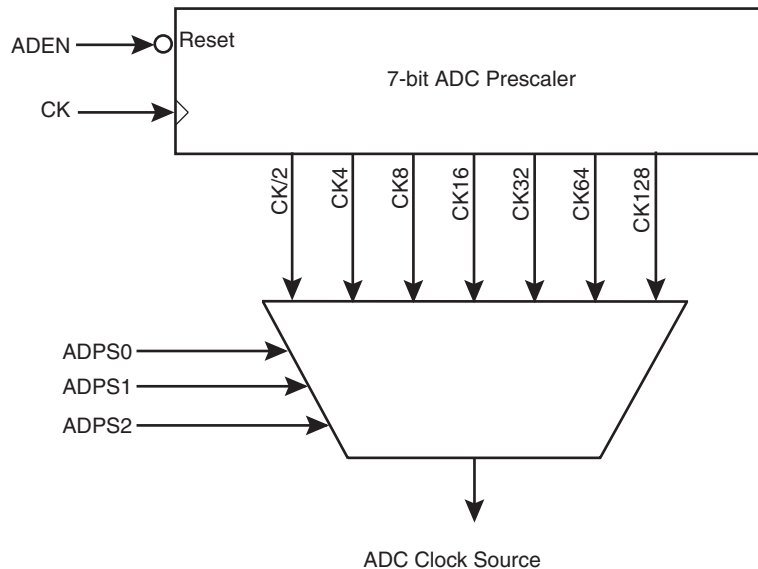

The successive approximation circuitry requires an input clock frequency between 15 kHz and 1 MHz to achieve maximum resolution. If a resolution of lower than 10 bits is required, the input clock frequency to the ADC can be higher than 200 kHz to achieve a higher sampling rate. See “ADC Characteristics” on page 54 for more details. The ADC module contains a prescaler, which divides the CK of 2 MHz clock input, to an acceptable ADC clock frequency.

The ADPS[0:2] bits in ADCSR are used to generate a proper ADC clock input frequency from 15.6 kHz to 1.0 MHz. The prescaler starts counting from the moment the ADC is switched on by setting the ADEN bit in ADCSR. The prescaler keeps running for as long as the ADEN bit is set and is continuously reset when ADEN is low.

When initiating a conversion by setting the ADSC bit in ADCSR, the conversion starts at the following rising edge of the ADC clock cycle.

A normal conversion takes 12 ADC clock cycles. In certain situations, the ADC needs more clock cycles for initialization and to minimize offset errors. Extended conversions take 25 ADC clock cycles and occur as the first conversion after the ADC is switched on (ADEN in ADCSR is set).

The actual sample-and-hold takes place 1.5 ADC clock cycles after the start of a conversion. When a conversion is complete, the result is written to the ADC data registers and ADIF is set. In Single Conversion Mode, ADSC is cleared simultaneously. The software may then set ADSC again and a new conversion will be initiated on the first rising ADC clock edge. In Free Running Mode, a new conversion will be started immediately after the conversion completes, while ADSC remains high. Using Free Running Mode and an ADC clock frequency of 1 MHz gives the lowest conversion time with a maximum resolution, 12 μ s, equivalent to 83 kSPS. For a summary of conversion times, see Table 21.

Figure 17. ADC Timing Diagram, Extended Conversion (Single Conversion Mode)

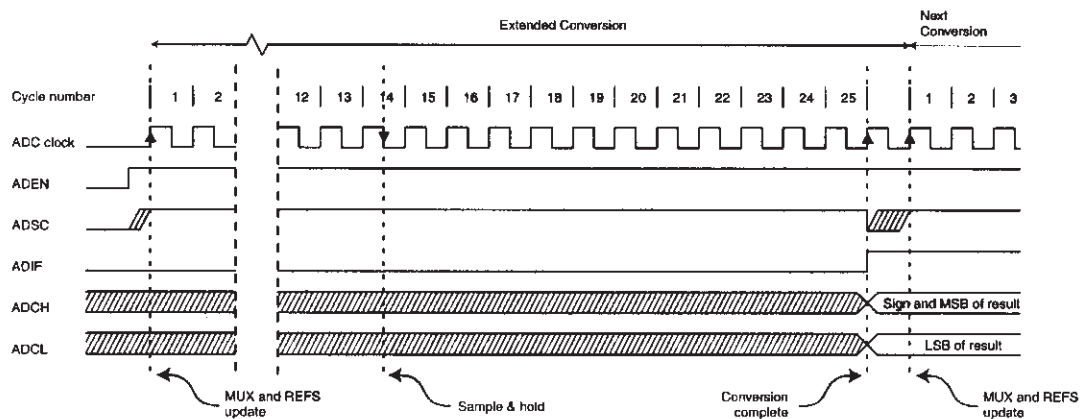

Figure 18. ADC Timing Diagram, Single Conversion

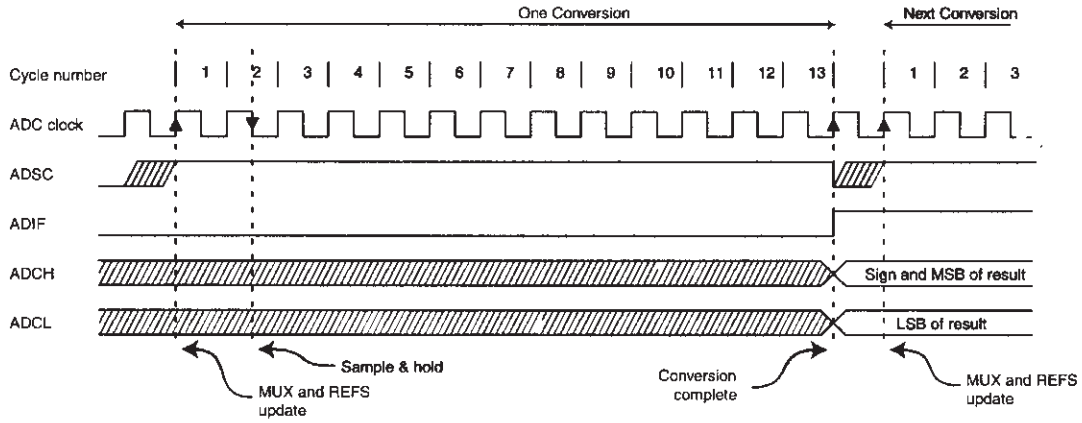

Figure 19. ADC Timing Diagram, Free Running Conversion

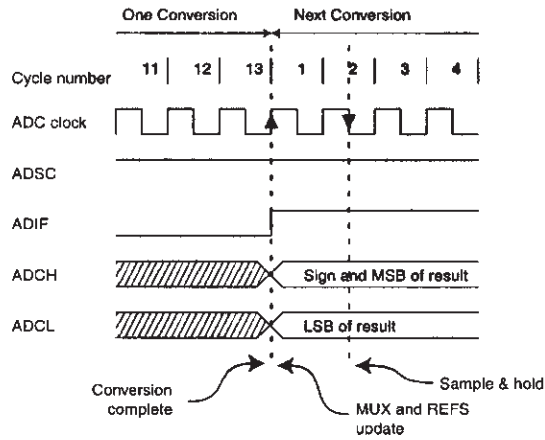

Table 21. ADC Conversion Time

Condition	Sample and Hold (Cycles from Start of Conversion)	Conversion Time (Cycles)	Conversion Time (μ s)
Normal Conversion	12	10	12 - 768

ADC Multiplexer Select Register – ADMUX

Bit	7	6	5	4	3	2	1	0	
\$08 (\$28)	–	–	–	–	MUX3	MUX2	MUX1	MUX0	ADMUX
Read/Write	R	R	R	R	R/W	R/W	R/W	R/W	
Initial Value	0	0	N/A	0	0	0	0	0	

- **Bits 7..3 – Res: Reserved Bits**

These bits are reserved bits in the AT43USB353M and always read as zero.

- **Bits 3..0 – MUX3..MUX0: Analog Channel Select Bits 3-0**

The value of these three bits selects which analog input ADC11..0 is connected to the ADC. See Table 22 for details.

If these bits are changed during a conversion, the change will not go into effect until this conversion is complete (ADIF in ADCSR is set).

Table 22. Input Channel Selections

MUX3.0	Single-ended Input
0000	ADC0
0001	ADC1
0010	ADC2
0011	ADC3
0100	ADC4
0101	ADC5
0110	ADC6
0111	ADC7
1000	ADC8
1001	ADC9
1010	ADC10
1011	ADC11
11XX	ADC0



ADC Control and Status Register – ADCSR

Bit	7	6	5	4	3	2	1	0	
\$07 (\$27)	ADEN	ADSC	ADFR	ADIF	ADIE	ADPS2	ADPS1	ADPS0	ADCSR
Read/Write	R/W	R/W	R/W	R/W	R/W	R/W	R/W	R/W	
Initial Value	0	0	0	0	0	0	0	0	

• **Bit 7 – ADEN: ADC Enable**

Writing a logical “1” to this bit enables the ADC. By clearing this bit to zero, the ADC is turned off. Turning the ADC off while a conversion is in progress will terminate this conversion.

• **Bit 6 – ADSC: ADC Start Conversion**

In Single Conversion Mode, a logical “1” must be written to this bit to start each conversion. In Free Running Mode, a logical “1” must be written to this bit to start the first conversion. The first time ADSC has been written after the ADC has been enabled or if ADSC is written at the same time as the ADC is enabled, an extended conversion will precede the initiated conversion. This extended conversion performs initialization of the ADC.

ADSC will read as one as long as a conversion is in progress. When the conversion is complete, it returns to zero. When a extended conversion precedes a real conversion, ADSC will stay high until the real conversion completes. Writing a “0” to this bit has no effect.

• **Bit 5 – ADFR: ADC Free Running Select**

When this bit is set (one), the ADC operates in Free Running Mode. In this mode, the ADC samples and updates the data registers continuously. Clearing this bit (zero) will terminate Free Running Mode.

• **Bit 4 – ADIF: ADC Interrupt Flag**

This bit is set (one) when an ADC conversion completes and the data registers are updated. The ADC Conversion Complete interrupt is executed if the ADIE bit and the I-bit in SREG are set (one). ADIF is cleared by the hardware when executing the corresponding interrupt handling vector. Alternatively, ADIF is cleared by writing a logical “1” to the flag. Beware that if doing a read-modify-write on ADCSR, a pending interrupt can be disabled. This also applies if the SBI and CBI instructions are used.

• **Bit 3 – ADIE: ADC Interrupt Enable**

When this bit is set (one) and the I-bit in SREG is set (one), the ADC Conversion Complete interrupt is activated.

• **Bits 2..0 – ADPS2..ADPS0: ADC Prescaler Select Bits**

These bits determine the division factor between the 12 MHz system clock frequency and the input clock to the ADC.

Table 23. ADC Prescaler Selections

ADPS2	ADPS1	ADPS0	Division Factor
0	0	0	2
0	0	1	2
0	1	0	4
0	1	1	8
1	0	0	16
1	0	1	32
1	1	0	64
1	1	1	128

ADC Data Register – ADCL and ADCH

Bit	7	6	5	4	3	2	1	0	
\$03 (\$23)	-	-	-	-	-	-	ADC9	ADC8	ADCH
\$24 (\$44)	ADC7	ADC6	ADC5	ADC4	ADC3	ADC2	ADC1	ADC0	ADCL
Read/Write	R	R	R	R	R	R	R	R	
Initial Value	0	0	0	0	0	0	0	0	

When an ADC conversion is complete, the result is found in these two registers. In Free Run Mode, it is essential that both registers are read, and that ADCL is read before ADCH.

Scanning Multiple Channels

Since change of analog channels is always delayed until a conversion is finished, the Free Run Mode can be used to scan multiple channels without interrupting the converter. Typically, the ADC Conversion Complete interrupt will be used to perform the channel shift. However, the user should take the following fact into consideration:

The interrupt triggers once the result is ready to be read. In Free Run Mode, the next conversion will start immediately when the interrupt triggers. If ADMUX is changed after the interrupt triggers, the next conversion has already started and the old setting is used.

ADC Characteristics

Symbol	Parameter	Condition	Min	Typ	Max	Units
	Resolution			10		Bits
	Integral Non-linearity	$V_{REF} = V_{CEXTA}$			4	LSB
	Differential Non-linearity	$V_{REF} = V_{CEXTA}$			4	LSB
	Zero Error (Offset)		-2		2	LSB
	Full Scale Error		-4		4	LSB
	V_{REF} input resistance	25°C	12	18	24	kΩ
	Analog Input Resistance			100		MΩ
	Conversion Time		12		768	μs
	Clock Frequency	at 50% duty cycle			1	MHz

I/O-Ports

All AVR ports have true Read-Modify-Write functionality when used as general digital I/O ports. This means that the direction of one port pin can be changed without unintentionally changing the direction of any other pin with the SBI and CBI instructions. The same applies for changing drive value if configured as output or enabling/disabling of pull-up resistors if configured as input.

Port A

Port A is an 8-bit bi-directional I/O port. The Port A output buffers can sink or source 2 mA.

Three I/O memory address locations are allocated for the Port A, one each for the Data Register PORTA, \$1B(\$3B), Data Direction Register (DDRA), \$1A(\$3A) and the Port A Input Pins (PINA) \$19(\$39). The Port A Input Pins address is read only, while the Data Register and the Data Direction Register are read/write.

All port pins have individually selectable pull-up resistors. When pins PA0 to PA7 are used as inputs and are externally pulled low, they will source current if the internal pull-up resistors are activated.

Port A Data Register – PORTA

Bit	7	6	5	4	3	2	1	0	
\$1B (\$3B)	PORTA7	PORTA6	PORTA5	PORTA4	PORTA3	PORTA2	PORTA1	PORTA0	PORTA
Read/Write	R/W	R/W	R/W	R/W	R/W	R/W	R/W	R/W	
Initial Value	0	0	0	0	0	0	0	0	

Port A Data Direction Register – DDRA

Bit	7	6	5	4	3	2	1	0	
\$1A (\$3A)	DDA7	DDA6	DDA5	DDA4	DDA3	DDA2	DDA1	DDA0	DDRA
Read/Write	R/W	R/W	R/W	R/W	R/W	R/W	R/W	R/W	
Initial Value	0	0	0	0	0	0	0	0	

Port A Input Pins Address – PINA

Bit	7	6	5	4	3	2	1	0	
\$19 (\$39)	PINA7 PINA6 PINA5 PINA4 PINA3 PINA2 PINA1 PINA0								PINA
Read/Write	R	R	R	R	R	R	R	R	
Initial Value	N/A	N/A	N/A	N/A	N/A	N/A	N/A	N/A	

The Port A Input Pins address (PINA) is not a register, and this address enables access to the physical value on each Port A pin. When reading PORTA the Port A Data Latch is read, and when reading PINA, the logical values present on the pins are read.

Port A as General Digital I/O

All 8 pins in Port A have equal functionality when used as digital I/O pins.

PAn, General I/O Pin: The DDAn bit in the DDRA register selects the direction of this pin, if DDAn is set (one), PAn is configured as an output pin. If DDAn is cleared (zero), PAn is configured as an input pin. If PORTAn is set (one) when the pin is configured as an input pin, the MOS pull-up resistor is activated. To switch the pull-up resistor off, the PORTAn has to be cleared (zero) or the pin has to be configured as an output pin. The Port A pins are tri-stated when a reset condition becomes active, even if the clock is not active.

Table 24. DDAn Effects on Port A Pins

DDAn	PORTAn	I/O	Comment
0	0	Input	Tri-state (Hi-Z)
0	1	Input	PAn will source current if ext. pulled low.
1	0	Output	Push-Pull Zero Output
1	1	Output	Push-Pull One Output

Note: n: 7,6...0, pin number.

Port D

Port D is a 7-bit bi-directional I/O port. Its output buffers can sink or source 2 mA.

Three I/O memory address locations are allocated for the Port D, one each for the Data Register - PORTD, \$12(\$32), Data Direction Register (DDRD), \$11(\$31) and the Port D Input Pins (PIND), \$10(\$30). The Port D Input Pins address is read only, while the Data Register and the Data Direction Register are read/write.

All port pins have individually selectable pull-up resistors. When pins PD0 to PD7 are used as inputs and are externally pulled low, they will source current if the internal pull-up resistors are activated

Some Port D pins have alternate functions as shown in Table 25.

Table 25. Port D Alternate Functions

Port Pin	Alternate Function
PD2	INT0, External Interrupt 0
PD3	INT1, External Interrupt 1
PD4	ICP, Timer/Counter, Input Capture
PD5	OC1A Timer/Counter1 Output Compare A
PD6	OC1B Timer/Counter1 Output Compare B

When the pins are used for the alternate function the DDRD and PORTD register has to be set according to the alternate function description.

Port D Data Register – PORTD

Bit	7	6	5	4	3	2	1	0	
\$12 (\$32)	–	PORTD6	PORTD5	PORTD4	PORTD3	PORTD2	PORTD1	PORTD0	PORTD
Read/Write	R/W	R/W	R/W	R/W	R/W	R/W	R/W	R/W	
Initial Value	0	0	0	0	0	0	0	0	

Port D Data Direction Register – DDRD

Bit	7	6	5	4	3	2	1	0	
\$11 (\$31)	–	DDD6	DDD5	DDD4	DDD3	DDD2	DDD1	DDD0	DDRD
Read/Write	R/W	R/W	R/W	R/W	R/W	R/W	R/W	R/W	
Initial Value	0	0	0	0	0	0	0	0	

Port D Input Pins Address – PIND

Bit	7	6	5	4	3	2	1	0	
\$10 (\$30)	–	PIND6	PIND5	PIND4	PIND3	PIND2	PIND1	PIND0	PIND
Read/Write	R	R	R	R	R	R	R	R	
Initial Value	N/A	N/A	N/A	N/A	N/A	N/A	N/A	N/A	

The Port D Input Pins address (PIND) is not a register, and this address enables access to the physical value on each Port D pin. When reading PORTD, the Port D Data Latch is read, and when reading PIND, the logical values present on the pins are read.

PortD as General Digital I/O

PD_n, General I/O Pin: The DDD_n bit in the DDRD register selects the direction of this pin. If DDD_n is set (one), PD_n is configured as an output pin. If DDD_n is cleared (zero), PD_n is configured as an input pin. If PORTD_n is set (one) when the pin is configured as an input pin, the MOS pull-up resistor is activated. To switch the pull-up resistor off, the PORTD_n has to be cleared (zero) or the pin has to be configured as an output pin. The Port D pins are tri-stated when a reset condition becomes active, even if the clock is not active.

Table 26. DDD_n Bits on Port D Pins

DDD _n	PORTD _n	I/O	Comment
0	0	Input	Tri-state (Hi-Z)
0	1	Input	PD _n will source current if ext. pulled low.
1	0	Output	Push-Pull Zero Output
1	1	Output	Push-Pull One Output

Note: n: 7, 6...0, pin number.

Programming the USB Module

The USB hardware consists of two devices, hub and function, each with their own device address and end-points. Its operation is controlled through a set of memory mapped registers. The exact configuration of the USB device is defined by the software and it can be programmed to operate as a compound device, or as a hub only or as a function only. The hub has the required control and interrupt end-points. The number of external downstream ports is programmable as 1 or 2. The DP and DM pins of the unused port(s) must be connected to ground. The USB function has one control end-point and 3 programmable end-points. All the end-points have their own FIFO. Function end-points 1 and 2 FIFOs are 64 bytes deep and function end-point 3 has an 8-byte FIFO. If the hub is disabled, one extra end-point becomes available to the function.

The USB Function

The USB function hardware is designed to operate in the single packet mode and to manage the USB protocol layer. It consists of a Serial Interface Engine (SIE), end-point FIFOs and a Function Interface Unit (FIU). The SIE performs the following tasks: USB signaling detection/generation, data serialization/de-serialization, data encoding/decoding, bit stuffing and un-stuffing, clock/data separation, and CRC generation/checking. It also decodes and manages all packet data types and packet fields.

The end-point FIFO buffers the data to be sent out or data received. The FIU manages the flow of data between the SIE, FIFO and the internal microcontroller bus. It controls the FIFO and monitors the status of the transactions and interfaces to the CPU. It initiates interrupts and acts upon commands sent by the firmware.

The USB function hardware of the AT43USB353M makes the physical interface and the protocol layer transparent to the user. To start the process, the firmware must first enable the end-points and which place them in receive mode by default. The device address by default is address 0. The USB function hardware then waits for a SETUP token from the host. When a valid the SETUP token is received, it automatically stores the DATA packet in end-point 0 FIFO and responds with an ACK. It then notifies the microcontroller through an interrupt. The microcontroller reads the FIFO and parses the request.

Transactions for the non-control end-points are even simpler. Once the end-point is enabled, it waits for an IN or an OUT token depending whether it is programmed as an IN or OUT end-point. For example, if it is an IN end-point, the microcontroller simply loads the data into the end-point's FIFO and sets a bit in the control and status register. The USB hardware will assemble the data in a USB packet and waits for an IN token. When it receives one, it automatically responds by transmitting the DATA packet and completes the transaction by waiting for the host's ACK. When one is received, the USB hardware will signal the microcontroller that the transaction has been completed successfully. Retries and data toggles are performed automatically by the USB hardware. When the IN end-point is not ready to send data, in the case where the microcontroller has not filled the FIFO, it will automatically respond with a NAK.

Similarly, an OUT end-point will wait for an OUT token. When one is received, it will store the data in the FIFO, completes the transaction and interrupt the microcontroller, which then reads the FIFO and enables the end-point for the next packet. If the FIFO is not cleared, the USB hardware will respond with a NAK.

A detailed description of how USB transactions are handled is described in the following sections. First for a control end-point and then for non-control end-points.

Control Transfers at Control End-point EP0

The description given below is for the function control end-point, but applies to the hub control end-point as well if the proper registers are used.

The following illustration describes the three possible types of control transfers – Control Write, Control Read and No-data control:

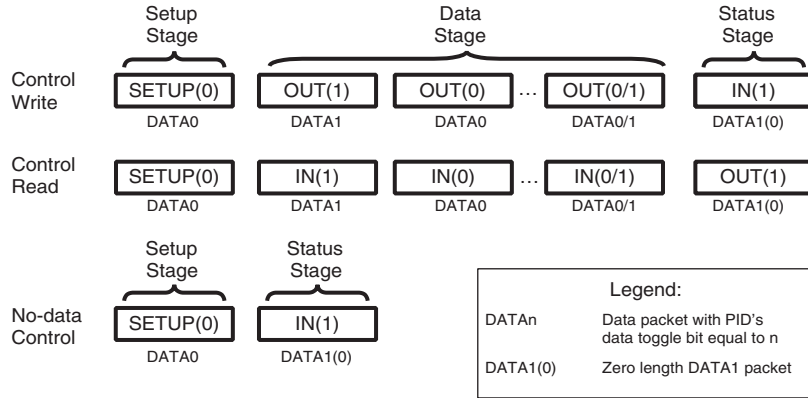

The following state diagram shows how the various state transitions are triggered. Additional decision making may take place within the response states to determine the next expected state. Unmarked arcs represent transitions that trigger immediately following completion of the response state processing. Stable states, those requiring an interrupt to exit having no unmarked arcs as exit paths, are shown in bold.

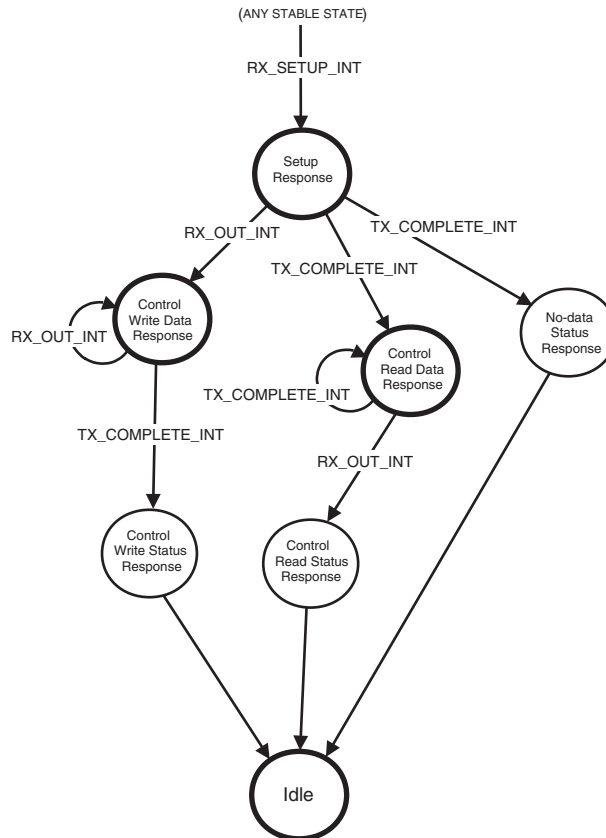

The following information describes how the AT43USB355's USB hardware and firmware operates during a control transfer between the host and the hub's or function's control endpoint.

Legend: DATA1/DATA0 = DATA packet with DATA1 or DATA2 PID
DATA1(0) = Zero length DATA1 packet

Idle State

This is the default state from power-up.

Setup Response State

The Function Interface Unit (FIU) receives a SETUP token with 8 bytes of data from the Host. The FIU stores the data in the FIFO, sends an ACK back to the host and asserts an RX_SETUP interrupt.

Hardware

1. SETUP token, DATA from Host
2. ACK to Host
3. Store data in FIFO
4. Set RX SETUP → INT

Firmware

5. Read UISR
6. Read CSR0
7. Read Byte Count
8. Read FIFO
9. Parse command data
10. Write to H/FCAR0:
 - a. If Control Read: set DIR, clear RX SETUP, fill FIFO, set TX Packet Ready in CAR0
 - b. If Control Write: clear DIR in CAR0
 - c. If no Data Stage: set Data End, clear DIR, set Force STALL in CAR0
11. Set UIAR[EP0 INTACK] to clear the interrupt source

**No-data Status
Response State**

The Function Interface Unit receives an IN token from the Host. The FIU responds with a zero length DATA1 packet until receiving an ACK from the host, then asserts a TX_COMPLETE interrupt.

Hardware

1. IN token from Host
2. Send DATA1(0)
3. ACK from Host
4. Set TX COMPLETE → INT

Firmware

5. Read UISR
6. Read CSR0
7. If SET ADDRESS, program the new Address, set ADD_EN bit
8. Clear TX_COMPLETE, clear Data End, set Force STALL in CAR0
9. Set UIAR[EP0 INTACK]

**Control Read Data
Response State**

The Function Interface Unit receives an IN token from the Host. The FIU responds with NAKs until TX_PACKET_READY is set. The FIU then sends the data in the FIFO upstream, retrying until it successfully receives an ACK from the host. Finally, the FIU clears the TX_PACKET_READY bit and asserts a TX_COMPLETE interrupt.

Hardware

1. IN token from Host
2. a. If TX Packet Ready = 1, send DATA0/DATA1
b. If TX Packet Ready = 0, send NAK
3. ACK from Host
4. Clear TX Packet Ready
Set TX Complete → INT

Firmware

5. Read UISR
6. Read CSR0
7. Clear TX COMPLETE in CAR0:
 - a. If more data: fill FIFO, set TX Packet Ready, set DIR in CAR0
 - b. If no more data: set Force STALL, set DATA END in CAR0
8. Set UIAR[EP0 INTACK] to clear interrupt source

Repeat steps 1 through 8

**Control Read Status
Response State**

The Function Interface Unit receives an OUT token from the Host with a zero length DATA1 packet. The FIU responds with a NAK until TX_COMPLETE is cleared. The FIU will then ACK the retried OUT token from the Host and assert an RX_OUT interrupt.

Hardware

1. OUT token from Host
2. DATA1(0) from Host
3. TX Complete = 0 ?
 - a. If yes, ACK to Host
Set RX OUT → INT
 - b. If no, NAK to Host

Firmware

4. Read UISR
5. Read CSR0
6. Clear RX OUT, set Data End, set Force Stall in H/FCAR0.
Note: A SETUP token will clear Data End, therefore, it is not cleared by FW in case Host retries.
7. Set UIAR[EP0 INTACK] to clear interrupt source

**Control Write Data
Response State**

The Function Interface Unit receives an OUT token from the Host with a DATA packet. The FIU places the incoming data into the FIFO, issues an ACK to the host, and asserts an RX_OUT interrupt.

Hardware

1. OUT token from Host
2. Put DATA0/DATA1 into FIFO
3. ACK to Host
4. Set RX OUT → INT

Firmware

5. Read UISR
6. Read CSR0
7. Read FIFO
8. Clear RX OUT
If last DATA packet, set Force STALL, set DATA END.
9. Set UIAR[EP0 INTACK] to clear the interrupt source

Repeat steps 1 through 9 until last DATA Packet:

Control Write Status Response State

The Function Interface Unit receives an IN token from the Host. The FIU responds with a zero length DATA1 packet, retrying until it receives an ACK back from the Host. The FIU then asserts a TX_COMPLETE interrupt.

Hardware

1. IN token from Host
2. Send DATA1(0)
3. ACK from Host
4. Set TX Complete → INT

Firmware

5. Read UISR
6. Read CSR0
7. Clear TX COMPLETE, clear Data End, set Force STALL in CAR0
8. Set UIAR[EP0 INTACK] to clear the interrupt source

**Interrupt/Bulk IN
Transfers at Function
End-point**

The firmware must first condition the end-point through the End-point Control Register, FEND-P1/2/3_CNTR:

Set end-point direction: set EPDIR

Set interrupt or bulk: EPTYPE = 11 or 10

Enable end-point: set EPEN

The Function Interface Unit receives an IN token from the Host. The FIU responds with NAKs until TX_PACKET_READY is set. The FIU then sends the data in the FIFO upstream, retrying until it successfully receives an ACK from the host. Finally, the FIU clears the TX_PACKET_READY bit and asserts a TX_COMPLETE interrupt.

1. Read UISR
2. Read FCSR1/2/3
3. Clear TX_COMPLETE
If more data: fill FIFO, set TX Packet Ready
Wait for TX_COMPLETE interrupt
If no more data: set DATA END in FCAR1/2/3
4. Set UIAR[FEP1/2/3 INTACK] to clear the interrupt source

**Interrupt/Bulk OUT
Transfers at Function
End-point EP1, 2 and 3**

The firmware must first condition the end-point through the End-point Control Register, FEND-P1/2/3_CNTR:

Set end-point direction: clear EPDIR

Set interrupt or bulk: EPTYPE = 11 or 10

Enable end-point: set EPEN

The Function Interface Unit receives an OUT token from the Host with a DATA packet. The FIU places the incoming data into the FIFO, issues an ACK to the host, and asserts an RX_OUT interrupt.

1. Read UISR
2. Read FCSR1/2/3
3. Read FIFO
4. Clear RX_OUT
If more data:
Wait for RX_OUT interrupt
If no more data: set DATA END
5. Set UIAR[FEP1/2/3 INTACK] to clear the interrupt source

USB Registers

The following sections describe the registers of the AT43USB353M's USB hub and function units.

Reading a bit for which the microcontroller does not have read access will yield a zero value result. Writing to a bit for which the microcontroller does not have write access has no effect.

Hub Address Register – HADDR

The USB hub contains an address register that contains the hub address assigned by the host. This Hub Address Register must be programmed by the microcontroller once it has received a SET_ADDRESS request from the host. The USB hardware uses the new address only after the status phase of the transaction is completed when the microcontroller has enabled the new address by setting bit 0 of the Global State Register. After power-up or reset, this register will contain the value of 0x00.

Hub Address Register – HADDR

Bit	7	6	5	4	3	2	1	0	
\$1FEF	SAEN	HADD6	HADD5	HADD4	HADD3	HADD2	HADD1	HADD0	HADDR
Read/Write	R/W	R/W	R/W	R/W	R/W	R/W	R/W	R/W	R/W
Initial Value	0	0	0	0	0	0	0	0	

- **Bit 7 – SAEN: Single Address Enable**

The Single Address Enable bit allows the microcontroller to configure the AT43USB353M into a single address or a composite device. Once this capability is enabled, the Hub End-point 0 (HEP0) is converted from a control end-point to a programmable function end-point FEP3; all the end-points would then operate on the single address.

- **Bit 6..0 – HADD6...0: Hub Address[6:0]**

Function Address Register – FADDR

The USB function contains an address register that contains the function address assigned by the host. This Function Address Register must be programmed by the microcontroller once it has received a SET_ADDRESS request from the host and completed the status phase of the transaction. After power up or reset, this register will contain the value of 0x00.

Function Address Register – FADDR

Bit	7	6	5	4	3	2	1	0	
\$1FEE	FEN	FADD6	FADD5	FADD4	FADD3	FADD2	FADD1	FADD0	FADDR
Read/Write	R/W	R/W	R/W	R/W	R/W	R/W	R/W	R/W	R/W
Initial Value	0	0	0	0	0	0	0	0	

- **Bit 7 – FEN: Function Enable**

The Function Enable bit (FEN) allows the firmware to enable or disable the function end-points. The firmware will set this bit after receipt of a reset through the hub, SetPortFeature[PORT_RESET]. Once this bit is set, the USB hardware passes to and from the host.

When the Single Address bit is set, the condition of FEN is ignored.

- **Bit 6..0 – FADD6...0: Function Address[6:0]**

End-point Registers

Hub End-point 0 Control Register – HEND-P0_CR

Function End-point 0 Control Register – FEND-P0_CR

Bit	7	6	5	4	3	2	1	0	
\$1FE7	EPEN	–	–	–	DTGLE	EPDIR	EPTYPE1	EPTYPE0	HEND-P0_CR
\$24 (\$44)	EPEN	–	–	–	DTGLE	EPDIR	EPTYPE1	EPTYPE0	FEND-P0_CR
Read/Write	R/W	R	R	R	R/W	R/W	R/W	R/W	
Initial Value	0	0	0	0	0	0	0	0	

- **Bit 7 – EPEN: End-point Enable**

0 = Disable end-point

1 = Enable end-point

- **Bit 6..4 – Reserved**

These bits are reserved in the AT43USB353M and will read as zero.

- **Bit 3 – DTGLE: Data Toggle**

Identifies DATA0 or DATA1 packets. This bit will automatically toggle and requires clearing by the firmware only in certain special circumstances.

- **Bit 2 – EPDIR: End-point Direction**

0 = Out

1 = In

- **Bit 1, 0 – EPTYPE: End-point Type**

These bits must be programmed as 0, 0.

Function End-point 1..3 Control Register – FEND-P1..3_CR

Bit	7	6	5	4	3	2	1	0	
\$1FE4	EPEN	–	–	–	DTGLE	EPDIR	EPTYPE1	EPTYPE0	FEND-P1_CR
\$1FE3	EPEN	–	–	–	DTGLE	EPDIR	EPTYPE1	EPTYPE0	FEND-P2_CR
\$1FE2					DTGLE	EPDIR	EPTYPE1	EPTYPE0	FEND-P3_CR
Read/Write	R/W	R	R	R	R/W	R/W	R/W	R/W	
Initial Value	0	0	0	0	0	0	0	0	

- **Bit 7 – EPEN: End-point Enable**

0 = Disable end-point

1 = Enable end-point

- **Bit 6..4 – Reserved**

These bits are reserved in the AT43USB353M and will read as zero.

- **Bit 3 – DTGLE: Data Toggle**



Identifies DATA0 or DATA1 packets. This bit will automatically toggle and requires clearing by the firmware only in certain special circumstances.

- **Bit 2 – EPDIR: End-point Direction**

0 = Out

1 = In

- **Bit 1, 0 – EPTYPE: End-point Type**

These bits programs the type of end-point.

Bit1	Bit0	Type
0	1	Isochronous
1	0	Bulk
1	1	Interrupt

Hub End-point 0 Data Register – HDR0

Function End-point 0..3 Data Register – FDR0..3

Bit	7	6	5	4	3	2	1	0	
\$1FD7	DATA7	DATA6	DATA5	DATA4	DATA3	DATA2	DATA1	DATA0	HDR0
\$1FD5	DATA7	DATA6	DATA5	DATA4	DATA3	DATA2	DATA1	DATA0	FDR0
\$1FD4	DATA7	DATA6	DATA5	DATA4	DATA3	DATA2	DATA1	DATA0	FDR1
\$1FD3	DATA7	DATA6	DATA5	DATA4	DATA3	DATA2	DATA1	DATA0	FDR2
\$1FD2	DATA7	DATA6	DATA5	DATA4	DATA3	DATA2	DATA1	DATA0	FDR3
Read/Write	R/W	R/W	R/W	R/W	R/W	R/W	R/W	R/W	R/W
Initial Value	0	0	0	0	0	0	0	0	

This register is used to read data from or to write data to the Hub End-point 0 FIFO.

- **Bit 7..0 – FDATA7..0: FIFO Data**

Hub End-point 1 has a single byte data register instead of a FIFO. This data register contains the hub and port status change bitmap. This data register is automatically updated by the USB hardware and is not accessible by the firmware. The bits in this register when read by the host will be:

Bit	7	6	5	4	3	2	1	0	
\$	-	-	-	-	P3 SC	P2 SC	P1 SC	H SC	HDR1
Read/Write	R/W	R/W	R/W	R/W	R/W	R/W	R/W	R/W	R/W
Initial Value	0	0	0	0	0	0	0	0	

- **Bit 7..4 – Reserved**

These bits are reserved in the AT43USB353M and will read as zero.

- **Bit 3 – P3 SC: Port 3 Status Change**
- **Bit 2 – P2 SC: Port 2 Status Change**
- **Bit 1 – P1 SC: Port 1 Status Change**
- **Bit 0 – H SC: Hub Status Change**

Hub End-point 0 Byte Count Register – HBYTE_CNT0

Function End-point 0..3 Byte Count Register – FBYTE_CNT0..3

The contents of these registers stores the number of bytes to be sent or that was received by USB Hub and Function end-points. This count includes the 16-bit CRC. To get the actual byte count of the data, subtract the count in the register by 2. The hub EP0 and function EP3 have 8 byte FIFOs while function EP1 and EP2 have 64 byte FIFOs. Hub End-point 1 has no byte count register.

Bit	7	6	5	4	3	2	1	0	
Hub EP0 \$1FCF	–	–	BYTCT5	BYTCT4	BYTCT3	BYTCT2	BYTCT1	BYTCT0	HBYTE_CNT0
Function EP0 \$1FCD	–	–	BYTCT5	BYTCT4	BYTCT3	BYTCT2	BYTCT1	BYTCT0	FBYTE_CNT0
Function EP1 \$1FCC	–	BYTCT6	BYTCT5	BYTCT4	BYTCT3	BYTCT2	BYTCT1	BYTCT0	FBYTE_CNT1
Function EP2 \$1FCB	–	BYTCT6	BYTCT5	BYTCT4	BYTCT3	BYTCT2	BYTCT1	BYTCT0	FBYTE_CNT2
Function EP3 \$1FCA	–	–	BYTCT5	BYTCT4	BYTCT3	BYTCT2	BYTCT1	BYTCT0	FBYTE_CNT3
Read/Write	R	R	R	R/W	R/W	R/W	R/W	R/W	
Initial Value	0	0	0	0	0	0	0	0	

- **Bit 7..6 – Reserved**

These bits are reserved in the AT43USB353M and will read as zero.

- **Bit 5..0 – BYTCT5..0: Byte Count – Length of End-point DATA Packet**

Hub End-point 0 Service Routine Register – HCSR0

Function End-point 0 Service Routine Register – FCSR0

Bit	7	6	5	4	3	2	1	0	
Function EP0 \$1FDF	-	-	-	-	STALL SENT	RX SETUP	RX OUT PACKET	TX COMPLETE	HCSR0
Function EP0 \$1FDD	-	-	-	-	STALL SENT	RX SETUP	RX OUT PACKET	TX COMPLETE	FCSR0
Read/Write	R	R	R	R	R	R	R	R	
Initial Value	0	0	0	0	0	0	0	0	

- **Bit 7..4 – Reserved**

These bits are reserved in the AT43USB353M and will read as zero.

- **Bit 3 – STALL SENT**

The USB hardware sets this bit after a STALL has been sent to the host. The firmware uses this bit when responding to a Get Status[End-point] request. It is a read only bit and that is cleared indirectly by writing a one to the STALL_SENT_ACK bit of the Control and Acknowledge Register.

- **Bit 2 – RX SETUP: Setup Packet Received**

This bit is used by control end-points only to signal to the microcontroller that the USB hardware has received a valid SETUP packet and that the data portion of the packet is stored in the FIFO. The hardware will clear all other bits in this register while setting RX SETUP. If interrupt is enabled, the microcontroller will be interrupted when RX SETUP is set. After the completion of reading the data from the FIFO, firmware should clear this bit by writing a one to the RX_SETUP_ACK bit of the Control and Acknowledge Register.

- **Bit 1 – RX OUT PACKET**

The USB hardware sets this bit after it has stored the data of an OUT transaction in the FIFO. While this bit is set, the hardware will NAK all OUT tokens. The USB hardware will not overwrite the data in the FIFO except for an early set-up. RX OUT Packet is used for the following operations:

1. Control write transactions by a control end-point.
2. OUT transaction with DATA1 PID to complete the status phase of a control end-point.

Setting this bit causes an interrupt to the microcontroller if the interrupt is enabled. FW clears this bit after the FIFO contents have been read by writing a one to the RX_OUT_PACKET_ACK bit of the Control and Acknowledge Register.

- **Bit 0 – TX COMPL: Transmit Completed**

This bit is used by a control end-point hardware to signal to the microcontroller that it has successfully completed certain transactions. TX Complete is set at the completion of a:

1. Control read data stage.
2. Status stage without data stage.
3. Status stage after a control write transaction.

This bit is read only and is cleared indirectly by writing a one to the TX_COMPLETE_ACK bit of the Control and Acknowledge Register.

Hub End-point 0 Control and Acknowledge Register – HCAR0

Function End-point 0 Control and Acknowledge Register – FCAR0

Bit	7	6	5	4	3	2	1	0	
Hub EP0 \$1FA7	DIR	DATA END	FORCE STALL	TX PACKET READY	STALL_ SENT_ ACK	RX_ SETUP_ ACK	RX_OUT_ PACKET_ ACK	TX_ COMPLETE_ ACK	HCAR0
Function EP0 \$1FDD	DIR	DATA END	FORCE STALL	TX PACKET READY	STALL_ SENT_ ACK	RX_ SETUP_ ACK	RX_OUT_ PACKET_ ACK	TX_ COMPLETE_ ACK	FCAR0
Read/Write	R/W	R/W	R/W	R/W	R/W	R/W	R/W	R/W	
Initial Value	0	0	0	0	0	0	0	0	

• **Bit 7 – DIR: Control transfer direction**

It is set by the microcontroller firmware to indicate the direction of a control transfer to the USB hardware. The FW writes to this bit location after it receives an RX SETUP interrupt. The hardware uses this bit to determine the status phase of a control transfer.

0 = control write or no data stage

1 = control read

• **Bit 6 – DATA END**

When set to 1 by firmware, this bit indicate that the microcontroller has either placed the last DATA packet in FIFO, or that the microcontroller has processed the last DATA packet it expects from the Host. This bit is used by control end-points only together with bit 4 (TX Packet Ready) to signal the USB hardware to go to the STATUS phase after the packet currently residing in the FIFO is transmitted. After the hardware completes the STATUS phase it will interrupt the microcontroller without clearing this bit.

• **Bit 5 – FORCE STALL**

This bit is set by the microcontroller to indicate a stalled end-point. The hardware will send a STALL handshake as a response to the next IN or OUT token, or whenever there is a control transfer without a Data Stage.

The microcontroller sets this bit if it wants to force a STALL. A STALL is sent if any of the following condition is encountered:

1. An unsupported request is received.
2. The host continues to ask for data after the data is exhausted.
3. The control transfer has no data stage.

• **Bit 4 – TX PACKET READY: Transmit Packet Ready**

When set by the firmware, this bit indicates that the microcontroller has loaded the FIFO with a packet of data. This bit is cleared by the hardware after the USB Host acknowledges the packet. For ISO end-points, this bit is cleared unconditionally after the data is sent.

This bit is used for the following operations:

1. Control read transactions by a control end-point.
2. IN transactions with DATA1 PID to complete the status phase for a control end-point, when this bit is zero but Data End set high (bit 4).
3. By a BULK IN or ISO IN or INT IN end-point.

The microcontroller should write into the FIFO only if this bit is cleared. After it has completed writing the data, it should set this bit. This data can be of zero length.

Hardware clears this bit after it receives an ACK. If the interrupt is enabled and if the TX Complete bit is set, clearing the TX Packet Ready bit by the hardware causes an interrupt to the microcontroller.

- **Bit 3 – STALL_SENT_ACK: Acknowledge Stall Sent Interrupt**

Firmware sets this bit to clear STALL SENT, CSR bit 3. The 1 written in the CSRACK3 bit is not actually stored and thus does not have to be cleared.

- **Bit 2 – RX_SETUP_ACK: Acknowledge RX SETUP Interrupt**

Firmware sets this bit to clear RX SETUP, CSR bit2. The 1 written in the CSRACK2 bit is not actually stored and thus does not have to be cleared.

- **Bit 1 – RX_OUT_PACKET_ACK: Acknowledge RX OUT PACKET Interrupt**

Firmware sets this bit to clear RX OUT PACKET, CSR bit1. The 1 written in the CSRACK1 bit is not actually stored and thus does not have to be cleared.

- **Bit 0 – TX_COMPLETE_ACK: Acknowledge TX COMPLETE Interrupt**

Firmware sets this bit to clear TX COMPLETE, CSR bit0. The 1 written in the CSRACK0 bit is not actually stored and thus does not have to be cleared.

Function End-point 0..3 Service Routine Register – FCSR0..3

Bit	7	6	5	4	3	2	1	0	
Function EP1 \$1FDC	-	-	-	-	STALL SENT	-	RX OUT PACKET	TX COMPLETE	FCSR1
Function EP2 \$1FDB	-	-	-	-	STALL SENT	-	RX OUT PACKET	TX COMPLETE	FCSR2
Function EP3 \$1FDA	-	-	-	-	STALL SENT	-	RX OUT PACKET	TX COMPLETE	FCSR3
Read/Write	R	R	R	R	R	R	R	R	
Initial Value	0	0	0	0	0	0	0	0	

- **Bit 7..4 – Reserved**

These bits are reserved in the AT43USB353M and will read as zero.

- **Bit 3 – STALL SENT**

The USB hardware sets this bit after a STALL has been sent to the host. The firmware uses this bit when responding to a Get Status[End-point] request. It is a read only bit and that is cleared indirectly by writing a one to the STALL_SENT_ACK bit of the Control and Acknowledge Register.

- **Bit 2 – Reserved**

This bit is reserved in the AT43USB353M and will read as zero.

- **Bit 1 – RX OUT PACKET**

The USB hardware sets this bit after it has stored the data of an OUT transaction in the FIFO. While this bit is set, the hardware will NAK all OUT tokens. The USB hardware will not overwrite the data in the FIFO except for an early set-up. RX OUT Packet is used by a BULK OUT or ISO OUT or INT OUT end-point.

Setting this bit causes an interrupt to the microcontroller if the interrupt is enabled. FW clears this bit after the FIFO contents have been read by writing a one to the RX_SETUP_ACK bit of the Control and Acknowledge Register.

- **Bit 0 – TX COMPLETE: Transmit Completed**

This bit is used by the end-point hardware to signal to the microcontroller that the IN transaction was completed successfully. This bit is read only and is cleared indirectly by writing a one to the TX_COMPLETE_ACK bit of the Control and Acknowledge Register.

Function End-point 0..3 Control and Acknowledge Register – FCAR0..3

Bit	7	6	5	4	3	2	1	0	
Function EP1 \$1FA4	-	DATA END	FORCE STALL	TX PACKET RDY	STALL_SENT-ACK	-	RX_OUT_PACKET_ACK	TX_COMPLETE_ACK	FCAR1
Function EP2 \$1FA3	-	DATA END	FORCE STALL	TX PACKET RDY	STALL_SENT-ACK	-	RX_OUT_PACKET_ACK	TX_COMPLETE_ACK	FCAR2
Function EP3 \$1FA2	-	DATA END	FORCE STALL	TX PACKET RDY	STALL_SENT-ACK	-	RX_OUT_PACKET_ACK	TX_COMPLETE_ACK	FCAR3
Read/Write	R	R/W	R/W	R/W	R/W	R	R/W	R/W	
Initial Value	0	0	0	0	0	0	0	0	

- **Bit 7 – Reserved**

This bit is reserved in the AT43USB353M and will read as zero.

- **Bit 6 – DATA END**

When set to 1 by firmware, this bit indicate that the microcontroller has either placed the last DATA packet in FIFO, or that the microcontroller has processed the last DATA packet it expects from the Host.

- **Bit 5 – FORCE STALL**

This bit is set by the microcontroller to indicate a stalled end-point. The hardware will send a STALL handshake as a response to the next IN or OUT token. The microcontroller sets this bit if it wants to force a STALL. A STALL is send if the host continues to ask for data after the data is exhausted.

- **Bit 4 – TX PACKET RDY: Transmit Packet Ready**

When set by the firmware, this bit indicates that the microcontroller has loaded the FIFO with a packet of data. This bit is cleared by the hardware after the USB Host acknowledges the packet. For ISO end-points, this bit is cleared unconditionally after the data is sent.

The microcontroller should write into the FIFO only if this bit is cleared. After it has completed writing the data, it should set this bit. This data can be of zero length.

The hardware clears this bit after it receives an ACK. If the interrupt is enabled and if the TX Complete bit is set, clearing the TX Packet Ready bit by the hardware causes an interrupt to the microcontroller.

- **Bit 3 – STALL_SENT_ACK: Acknowledge Stall Sent Interrupt**

Firmware sets this bit to clear STALL SENT, CSR bit 3. The 1 written in the CSRACK3 bit is not actually stored and thus does not have to be cleared.

- **Bit 2 – Reserved**

This bit is reserved in the AT43USB353M and will read as zero.

- **Bit 1 – RX_OUT_PACKET_ACK: Acknowledge RX OUT PACKET Interrupt**

Firmware sets this bit to clear RX OUT PACKET, CSR bit1. The 1 written in the CSRACK1 bit is not actually stored and thus does not have to be cleared.

- **Bit 0 – TX_COMPLETE_ACK: Acknowledge TX COMPLETE Interrupt**

Firmware sets this bit to clear TX COMPLETE, CSR bit0. The 1 written in the CSRACK0 bit is not actually stored and thus does not have to be cleared.

USB Hub

The hub in a USB system provides for the electrical interface between USB devices and the host. The major functions that the hub must supports are:

- Connectivity
- Power management
- Device connect and disconnect
- Bus fault detection and recovery
- Full speed and low speed device support

A hub consists of two major components: a hub repeater and a hub controller. The hub repeater is responsible for:

- Providing upstream connectivity between the selected device and the Host
- Managing connectivity setup and tear-down
- Handling bus fault detection and recovery
- Detecting connect/disconnect on each port

The Hub Controller is responsible for:

- Hub enumeration
- Providing configuration information to the host
- Providing status of each port to the host
- Controlling each port per host command

The first two tasks of the Hub Controller are similar to that of a USB function and will not be described in detail in the following section. The descriptions will cover the features of the AT43USB353M's hub and how to program it to make a USB-compliant hub.

Control transactions for the Hub Control End-point proceed exactly the same way as those described for the embedded function. The operation of the Hub's End-point 1 is fully implemented in the hardware and does not need any firmware support. Any status changes within the hub will automatically update Hub End-point 1, which will be sent to the host at the next IN token that is addressed to it. If no change has occurred, the interrupt end-point will respond with a NAK.

Hub General Registers

Global State Register – GLB_STATE

Bit	7	6	5	4	3	2	1	0	
\$1FFB	-	-	-	SUSP FLG	RESUME FLG	RMWUPE	CONFIG	HADD EN	GLB_STATE
Read/Write	R	R	R	R	R	R/W	R/W	R/W	
Initial Value	0	0	0	0	0	0	0	0	

- **Bit 7...5 – Reserved Bits**

These bits are reserved in the AT43USB353M and will read as zeros.

- **Bit 4 – SUSP FLG: Suspend Flag**

This bit is set to 1 while the USB hardware is in the suspended state. This bit is a firmware read only bit. It is set and cleared by the USB hardware.

- **Bit 3 – RESUME FLG: Resume Flag**

When the USB hardware receives a resume signal from the upstream device it sets this bit. This bit will stay set until the USB hardware completes the downstream resume signaling. This bit is a firmware read only bit. It is set and cleared by the USB hardware.

- **Bit 2 – RMWUPE: Remote Wakeup Enable**

This bit is set if the host enables the hub's remote wakeup feature.

- **Bit 1 – CONFIG: Configured**

This bit is set by firmware after a valid SET_CONFIGURATION request is received. It is cleared by a reset or by a SET_CONFIGURATION with a value of 0.

- **Bit 0 – HADD EN: Hub Address Enabled**

This bit is set by firmware after the status phase of a SET_ADDRESS request transaction so the hub will use the new address starting at the next transaction.

Hub Status Register

In the AT43USB353M overcurrent detection and port power switch control output processing is done in firmware. The hardware is designed so that various types of hubs are possible just through firmware modifications.

1. Hub local power status, bits 0 and 2, are optional features and apply to hubs that report on a global basis. If this feature is not used, both these bits should be programmed to 0. To use this feature, the firmware needs to know the status of the local power supply, which requires an input pin and extra internal or external circuitry.
2. Hub overcurrent status, bits 1 and 3, apply to self powered hubs with bus powered SIE only, or hubs that are programmable as self/bus powered. The firmware should clear these two bits to 0.

The firmware uses bits 1 and 3 to generate bit 0 of the Hub and Port Status Change Bitmap which is transmitted through the Hub End-point1 Data Register. Bit 0 of this register is a 1 whenever bit 1 or 3 of HSTR is a 1.

Hub Status Register – HSTR

Bit	7	6	5	4	3	2	1	0	
\$1FC7	–	–	–	–	OVLSC	LPSC	OVI	LPS	HSTR
Read/Write	R	R	R	R	R/W	R/W	R/W	R/W	
Initial Value	0	0	0	0	0	0	0	0	

- **Bit 7..4 – Reserved**

These bits are reserved in the AT43USB355 and will read as zero.

- **Bit 3 – OVLSC: Overcurrent Status Change**

0 = No change has occurred on Overcurrent Indicator

1 = Overcurrent Indicator has changed

- **Bit 2 – LPSC: Hub Local Power Status Change**

0 = No change has occurred on Local Power Status

1 = Local Power Status has changed

- **Bit 1 – OVI: Overcurrent Indicator**

0 = All power operations normal

1 = An overcurrent exist on a hub wide basis

- **Bit 0 – LPS: Hub Local Power Status**

0 = Local power supply is good

1 = Local power supply is lost (inactive)

Hub Port Control Register – HPCON

Bit	7	6	5	4	3	2	1	0	
\$1FC5	–	HPCON2	HPCON1	HPCON0	–	HPADD2	HPADD1	HPADD0	HPCON
Read/Write	R	R/W	R/W	R/W	R	R/W	R/W	R/W	
Initial Value	0	0	0	0	0	0	0	0	

- **Bit 7 – Reserved**

This bits is reserved in the AT43USB353M and will read as zero.

- **Bit 6..4 – HPCON2..0: Hub Port Control Command**

These bits are written by firmware to control the port states upon receipt of a Host request.

Bit6	Bit5	Bit4	Action
0	0	0	Disable port
0	0	1	Enable port
0	1	0	Reset and enable port
0	1	1	Suspend port
1	0	0	Resume port

Disable Port = ClearPortFeature(PORT_ENABLE)

Action: USB hardware places addressed port in disabled state. Port 1 is placed in disabled state by firmware.

Enable Port = SetPort Feature(PORT_ENABLE)

Action: USB hardware places addressed port in enabled state. Firmware is responsible for placing Port 1 in enabled state.

Reset and Enable Port = SetPort Feature(PORT_RESET)

Action: USB hardware drives reset signaling through addressed port. USB hardware and firmware resets their embedded function registers to the default state.

Suspend Port = SetPortFeature(PORT_SUSPEND)

Action: USB hardware places port in idle state and stops propagating traffic through the addressed port. Firmware places Port 1 in suspend state by disabling its end-points and placing the peripheral function in its low power state.

Resume Port = ClearPortFeature(PORT_SUSPEND)

Action: USB hardware sends resume signaling to addressed port and then enables port. Firmware takes the embedded function out of the suspend state and enables Port 1's end-points.

- **Bit 3 – Reserved**

This bits is reserved in the AT43USB353M and will read as zero.

- **Bit 2..0 – HPCON2..0: Hub Port Address**

These bits define which port is being addressed for the command defined by bits [2:0].

Bit2	Bit1	Bit0	Port addresses
0	1	1	Port3
0	1	0	Port2

Selective Suspend and Resume

The host can selectively suspend and resume a port through the Set Port Feature (PORT_SUSPEND) and Clear Port Feature (PORT_SUSPEND).

A port enters the suspend state after the microcontroller interprets the suspend request and sets the appropriate bits of the Hub Port Control Register, HPCON. From this point on the hub repeater hardware is responsible for proper actions in placing Ports 2:3 in the suspend mode. For Port 1, the embedded function port, the hardware will stop responding to any normal bus traffic, but the microcontroller firmware must place all external circuitry associated with the function in the low-power state.

A port exits from the suspend state when the hub receives a Clear Port Feature (PORT_SUSPEND) or Set Port Feature (PORT_RESET). If the Clear Port Feature (PORT_SUSPEND) is directed towards Ports 2:3, the USB hardware drives a “K” downstream for at least 20 ms followed by a low speed EOP. It then places the port in the enabled state. A Clear Port Feature (PORT_SUSPEND) to Port 1 (the embedded function) causes the firmware to wait 20 ms, take the embedded function out of the suspended state and then enable the port.

The ports can also exit from the suspended state through a remote wakeup if this feature is enabled. For Ports 2:3, this means detection of a connect/disconnect or an upstream directed J to K signaling. Remote wakeup for the embedded function is initiated through an external interrupt at INT0.

Hub Port Status Register

The bits in this register are used by the microcontroller firmware when reporting a port's status through the Port Status Field, *wPortStatus*. Bits 3 (POCI) and 5 (PPSTAT) are used by the USB hardware and are the only two bits that the firmware should set or clear. All other bits should not be modified by the firmware.

Hub Port Status Register – HPSTAT2, 3

Bit	7	6	5	4	3	2	1	0	
Port1 \$1FB8	–	LSP	PPSTAT	PRSTAT	POCI	PSSTAT	PESTAT	PCSTAT	HPSTAT1
Port2 \$1FB9	–	LSP	PPSTAT	PRSTAT	POCI	PSSTAT	PESTAT	PCSTAT	HPSTAT2
Port3 \$1FBA	–	LSP	PPSTAT	PRSTAT	POCI	PSSTAT	PESTAT	PCSTAT	HPSTAT3
Read/Write	R	R	R/W	R	R/W	R	R	R	
Initial Value	0	0	0	0	0	0	0	0	

- **Bit 7 – Reserved**

This bit is reserved in the AT43USB353M and will read as zero.

- **Bit 6 – LSP: Low-speed Device Attached**

0 = Full-speed device attached to this port

1 = Slow-speed device attached to this port

Set to 0 for Port 1 (full-speed only). Set and cleared by the hardware upon detection of device at EOF2.

- **Bit 5 – PPSTAT: Port Power Status**

0 = Port is powered OFF

1 = Port is powered ON

Set to 1 for Port 1. Set and cleared based on present status of port power.

- **Bit 4 – PRSTAT: Port Reset Status**

0 = Reset signaling not asserted

1 = Reset signaling asserted

Set and cleared by the hardware as a result of initiating a port reset by Port Control Register.

- **Bit 3 – POCI: Port Overcurrent Indicator**

0 = Power normal

1 = Overcurrent exist on port

Set to 0 for Port 1. Set and cleared by firmware upon detection of an overcurrent or removal of an overcurrent.

- **Bit 2 – PSSTAT: Port Suspend Status**

0 = Port not suspended

1 = Port suspended

Set and cleared by the hardware as controlled through Port Control Register.

- **Bit 1 – PESTAT: Port Enable Status**

0 = Port is disabled

1 = Port is enabled

Set and cleared by the hardware as controlled through Port Control register.

- **Bit 0 – PCSTAT: Port Connect Status**

0 = No device on this port

1 = Device present on this port

Set to 1 for Port 1. Set and cleared by the hardware after sampling of connect status at EOF2.

- **Overcurrent Detect Register – UOVCR**

Bits 3, 2 in this register enable overcurrent detection while the hub is in the suspend state.

Bit	7	6	5	4	3	2	1	0	
\$1FF2	–	–	–	–	OVC3	OVC2	–	–	UOVCR
Read/Write	R	R	R	R	R/W	R/W	R	R	
Initial Value	0	0	0	0	0	0	0	0	

- **Bit 7..4 – Reserved**

These bits are reserved in the AT43USB353M and will read as zero.

- **Bit 3 – OVC3**

Setting this bit enables the hub to detect an overcurrent on a port while the hub is in the suspend state. The overcurrent condition is signaled by a 1 to 0 transition at PD1.

- **Bit 2 – OVC2**

Setting this bit enables the hub to detect an overcurrent on a port while the hub is in the suspend state. The overcurrent condition is signaled by a 1 to 0 transition at PD0.

- **Bit 1..0 – Reserved**

These bits are reserved in the AT43USB353M and will read as zero.

- **Hub Port State Register – HPSTAT2, 3**

Bit	7	6	5	4	3	2	1	0	
Port2 \$1FA9	–	–	–	–	–	–	DPSTATE	DMSTATE	PSTATE2
Port3 \$1FAA	–	–	–	–	–	–	DPSTATE	DMSTATE	PSTATE3
Read/Write	R	R	R	R	R	R	R	R	
Initial Value	0	0	0	0	0	0	0	0	

These registers contain the state of the ports' DP and DM pins, which will be sent to the host upon receipt of a GetBusState request.

- **Bit 7..2 – Reserved**

These bits are reserved in the AT43USB353M and will read as zero.

- **Bit 1 – DPSTATE: DPlus State**

Value of DP at last EOF. Set and cleared by hardware at EOF2.

Set to 1 for Port 1.

- **Bit 0 – DMSTATE: DMinus State**

Value of DM at last EOF. Set and cleared by hardware at EOF2.

Set to 0 for Port 1.

Hub Port Status Change Register – PSCR1..3

Bit	7	6	5	4	3	2	1	0	
Port1 \$1FB0	–	–	–	RSTSC	POCIC	PSSC	PESC	PCSC	PSCR1
Port2 \$1FB1	–	–	–	RSTSC	POCIC	PSSC	PESC	PCSC	PSCR2
Port3 \$1FB2	–	–	–	RSTSC	POCIC	PSSC	PESC	PCSC	PSCR3
Read/Write	R	R	R	R	R	R	R	R	
Initial Value	0	0	0	0	0	0	0	0	

The microcontroller firmware uses the bits in this register to monitor when a port status change has occurred, which then gets reported to the host through the Port Change Field *wPortChange*.

Except for bit 3, the Port Overcurrent Indicator Change, the bits in this register are set by the USB hardware. Otherwise, the firmware should only clear these bits.

- **Bit 7..5 – Reserved**

These bits are reserved in the AT43USB353M and will read as zero.

- **Bit 4 – RSTSC: Port Reset Status Change**

0 = No change

1 = Reset complete

This bit is set by the USB hardware after it completes RESET signaling which is initiated when the Reset and Enable Port command is detected at the Port Control Register, HPCON. The firmware sends this command when it decodes a SetPortFeature(PORT_RESET) request from the host.

At EOF2 after the hardware completes the port reset, the hardware sets the Port Enable Status bit and clears the Port Reset Status bit of the Hub Port Status Register, HPSTAT. Cleared by firmware, ClearPortFeature(PORT_RESET).

- **Bit 3 – POCIC: Port Overcurrent Indicator Change**

0 = No change has occurred on Overcurrent Indicator

1 = Overcurrent Indicator has changed

This bit is relevant to hubs with individual overcurrent reporting only. The firmware sets this bit as a result of detecting overcurrent at the ports OVC# pin. The firmware clears bit through ClearPortFeature(PORT_OVER_CURRENT). For Port 1, this bit is always cleared.

- **Bit 2 – PSSC: Port Suspend Status Change**

0 = No change

1 = Resume completed

Port 2, 3 set by hardware upon completion of firmware initiated resume process. Port 1 set by firmware 20 ms after the next EOF2 after completion of resume process. RESUME signaling is initiated through global resume, selective resume and remote wakeup. Cleared by firmware via host request ClearPortFeature(PORT_SUSPEND).

- **Bit 1 – PESC: Port Enable/Disable Status Change**

0 = No change has occurred on Port Enable/Disable Status

1 = Port Enable/Disable status has changed



Set by hardware due to babble, physical disconnect or overcurrent except for Port 1 in which case it is set by hardware at EOF2 due to hardware events. Cleared by firmware via Host request ClearPortFeature(PORT_ENABLE).

- **Bit 0 – PCSC: Port Connect Status Change**

0 = No change has occurred on Current Connect Status

1 = Current Connect Status has changed

This bit is set by hardware at EOF2 after it detects a connect or disconnect at a port, except for Port 1. Hardware sets this bit for Port 5 after a hub reset. Cleared by firmware via Host request ClearPortFeature(PORT_CONNECTION).

Hub and Port Power Management

Overcurrent protection and power switching is required for the external downstream ports only. In the AT43USB353M, these tasks are completely programmable. This means that any type of hub is achievable with the AT43USB353M: self-powered or bus-powered hubs, per port or global overcurrent protection, individual or ganged port power switching.

The use of the MCU's GPIO pins are required to interface to the external power supply monitoring and switching. The on-chip hardware of the AT43USB353M contains the circuitry to handle all the possible combinations of port power management tasks. The firmware defines the exact configuration.

Overcurrent Sensing

The AT43USB353M is capable of detecting overcurrent during active operation only, or during any condition even when the hub is in the suspended state. When overcurrent in the active state only is desired, any GPIO pin of the AT43USB353M can be used to sense and the overcurrent condition. Control of the condition must be performed by the firmware. If overcurrent detection under any condition is desired, then specific GPIO pins must be used to sense the overcurrent and the proper bit(s) of UOVCER set. In Global Overcurrent Protection mode, overcurrent sensing must be routed to GPIO PD0. In Individual Port Overcurrent Protection mode Port2 and Port 3 overcurrent sensing must be assigned to GPIO PD0 and PD1. In the following description, it is assumed that overcurrent protection is required under any condition.

1. **Global Overcurrent Protection** – In this mode, the Port Overcurrent Indicator and Port Overcurrent Indicator Change should be set to 0's. For the AT43USB353M an external solid state switch, such as the Micrel MIC2025-2, is required to switch power to the external USB ports. The FLG output of the switch should be connected to PD0. When an overcurrent occurs, FLG is asserted and the firmware should set the Hub Overcurrent Indicator and Hub Overcurrent Indicator Change and switch off power to all external downstream ports. The hub status change is reported on the next IN token through the hub's interrupt endpoint, Endpoint1.
2. **Individual Port Overcurrent Protection** – The Hub Overcurrent Indicator and Hub Overcurrent Indicator Change bits should be set to 0's. One MIC2026-2 is required for the two USB ports. The FLG output of the MIC2026-2 associated with Port2 should be connected to GPIO PD0 and the other FLG output to PD1. An overcurrent is indicated by assertion of FLG. The firmware sets the corresponding port's Overcurrent Indicator and the Overcurrent Indicator Change bits and switches off power to the port. At the next IN token from the Host, the AT43USB353M reports the port status change through the hub's Endpoint1.

Port Power Switching

1. **Gang Power Switching** – One of the microcontroller GPIO pins, PWRN, must be programmed as an output to control the external switch such as the MIC2025-2. Switch ON is requested by the USB Host through the SetPortFeature(PORT_POWER) request. Switch OFF is executed upon receipt of a ClearPortFeature(PORT_POWER) or upon detecting an overcurrent condition. The firmware clears the Power Control Bit. Only if all of the Power Control Bits of ports 2 and 3 are cleared should the firmware deassert the PWRN pin.
2. **Individual Power Switching** – Two microcontroller GPIO pins, PWR2N and PWR3N, must be assigned for each USB port to control the external switch such as the MIC2026-2. Each of the Power Control Bits controls one PWRxN.
3. **Multiple Ganged Overcurrent Protection** – Overcurrent sensing is grouped physically into one or more gangs, but reported individually.

Figure 20 shows a simplified diagram of a power management circuit of an AT43USB353M based hub design with global overcurrent protection and ganged power switching.

Figure 20. Port Power Management

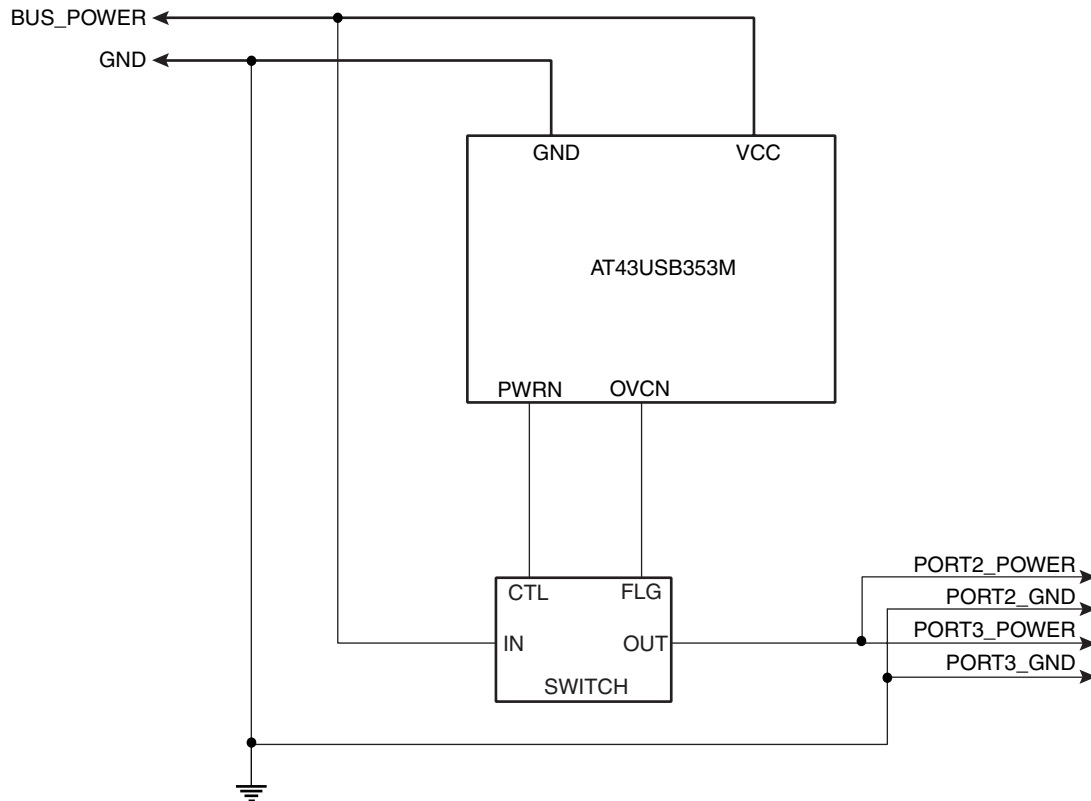

Suspend and Resume

The AT43USB353M enters suspend only when requested by the USB host through bus inactivity for at least 3 ms. The USB hardware would detect this request, sets the GLB_SUSP bit of SPRSR, Suspend/Resume Register, and interrupts the microcontroller if the interrupt is enabled. The microcontroller should shut down any peripheral activity and enter the Power Down mode by setting the SE and SM bits of MCUCR and then executes the SLEEP instruction. The USB hardware shuts off the oscillator and PLL.

Global Resume

Global resume is signaled by a J to K state change on Port0. The USB hardware enables the oscillator/PLL, propagates the RESUME signaling, and sets the RSM bit of the SPRSR, which generates an interrupt. The microcontroller starts executing where it left off and services the interrupt. As part of the ISR, the firmware clears the GLB_SUSP bit.

Remote Wakeup

While the AT43USB353M is in global suspend, resume signaling is also possible through remote wakeup if the remote wakeup feature is enabled. Remote wakeup is defined as a port connect, port disconnect or resume signaling received at a downstream port or, in case of the embedded function, through an external interrupt.

A remote wakeup initiated at a downstream port is similar in many respects to a global resume. The USB hardware enables the oscillator/PLL, propagates the RESUME signaling, and sets the RSM bit of the SPRSR which generates an interrupt. The microcontroller starts executing where it left off and services the interrupt. As part of the ISR, the firmware clears the GLB_SUSP bit.

A remote wakeup from the embedded function is initiated through INT0 or the external interrupt, INT1, which enables the oscillator/PLL and the USB hardware. The USB hardware drives RESUME signaling and sets the FRMWUP and RSM bits of SPRSR which generates an interrupt to the microcontroller. The microcontroller starts executing where it left off and services the interrupt. As part of the ISR, the firmware clears the GLB SUSP bit.

At completion of RESUME signaling, the USB hardware sets the Port Suspend Status Change bits of the Hub Port Status Change Registers.

Selective Suspend and Resume

See section on Hub Port Control Register, HPCON.

Suspend and Resume Process

Global Suspend

The Host stops sending packets, the hardware detects this as global suspend signaling and stops all downstream signaling. Finally, the hardware asserts the GLB_SUSP interrupt.

- | Hardware | Firmware |
|--------------------------------------|--|
| | 1. Host stops sending packets |
| 2. Global suspend signaling detected | |
| 3. Stop downstream signaling | |
| 4. Set GBL SUS bit → interrupt | |
| | 5. Shut down any peripheral activity |
| | 6. Set Sleep Enable and Sleep Mode bits of MCUCR |
| | 7. Set GPIO to low power state if required |
| | 8. Set UOVCR bit 2 |
| | 9. Execute SLEEP instruction |
| 10. SLEEP bit detected | |
| 11. Shut off oscillator | |

Global Resume

The Host resumes signaling, the hardware detects this as global resume and propagates this signaling to all downstream ports. Finally, the hardware enables the oscillator and asserts the RSM interrupt.

Hardware

1. Host resumes signaling
2. Resume signaling detected
3. Propagate signaling downstream
4. Enable oscillator
5. Set RSM bit → interrupt

Firmware

6. Reset RSM and GBL SUSP bits
7. Restore GPIO states if required
8. Clear UOVCE bit 2
9. Enable peripheral activity

Remote Wake-up, Downstream Ports

The hardware detects a connect/disconnect/port resume and propagates resume signaling upstream. Finally, the hardware enables the oscillator and asserts the RSM interrupt.

Hardware

1. Connect/disconnect/port resume detected
2. Propagate resume signaling
3. Enable Oscillator
4. Set RSM bit → interrupt

Firmware

5. Reset RSM and GBL SUSP bits
6. Restore GPIO states if required
7. Clear UOVCE bit 2
8. Enable peripheral activity

Remote Wake-up, Embedded Function

The hardware detects an INT0/INT1 and propagates resume signaling upstream. Finally, the hardware enables the oscillator and asserts the RSM and FRMWUP interrupts.

Hardware

1. External event activates INT0/INT1
2. Propagate resume signaling
3. Enable Oscillator
4. Set RSM and FRMWUP bits → interrupt

Firmware

5. Clear GLB SUSP, RSM, FRMWUP bits
6. Restore GPIO states if required
7. Clear UOVCE bit 2
8. Enable peripheral activity

*Selective Suspend,
Downstream Ports*

Hardware

3. Suspend or resume port per command

Firmware

1. Set or Clear Port Feature PORT_SUSPEND decoded
2. Write HPCON[2:0] and HPADD[2:0] bits

*Selective Suspend,
Embedded Function*

Hardware

Firmware

1. Set Port Feature PORT_SUSPEND decoded
2. Disable Port 1's end-points
3. Set GPIO to low power state if required

*Selective Resume,
Embedded Function*

Hardware

Firmware

6. Send updated port status at next IN to end-point1
1. Clear Port Feature PORT_SUSPEND decoded
 2. Clear Port 1 suspend status bit
 3. Restore GPIO states if required
 4. Wait 23 ms, then set enable status bit and suspend change bit
 5. Enable Port 1 end-points

Electrical Specification

Absolute Maximum Ratings

Stresses beyond those listed below may cause permanent damage to the device. This is a stress rating only and functional operation of the device at these or any other conditions beyond those indicated in the operational sections of this specification is not implied. Exposure to absolute maximum rating conditions for extended periods may affect device reliability.

Table 27. Absolute Maximum Ratings

Symbol	Parameter	Condition	Min	Max	Unit
V _{CC5}	5V Power Supply			5.5	V
V _I	DC input voltage		-0.3V	V _{CEXT} +0.3 4.6 max	V
V _O	DC output voltage		-0.3	V _{CEXT} +0.3 4.6 max	V
T _O	Operating temperature		-40	+125	°C
T _S	Storage temperature		-65	+150	°C

Note: V_{CEXT} is the voltage of CEXT1, CEXT2 and CEXTA.

DC Characteristics

The values shown in Table 28 are valid for T_A = 0°C to 85°C, V_{CC} = 4.4 to 5.25V, unless otherwise noted.

Table 28. Power Supply

Symbol	Parameter	Condition	Min	Max	Unit
V _{CC}	5V Power Supply		4.4	5.25	V
I _{CC}	5V Supply Current			30	mA
I _{CCS}	Suspended Device Current			500	μA

Table 29. USB Signals: DPx, DMx

Symbol	Parameter	Condition	Min	Max	Unit
V _{IH}	Input Level High (driven)		2.0		V
V _{IHZ}	Input Level High (floating)		2.7		V
V _{IL}	Input Level Low			0.8	V
V _{DI}	Differential Input Sensitivity	DPx and DMx	0.2		V
V _{CM}	Differential Common Mode Range		0.8	2.5	V
V _{OL1}	Static Output Low	RL of 1.5 kΩ to 3.6V		0.3	V
V _{OH1}	Static Output High	RL of 15 kΩ to GND	2.8	3.6	V
V _{CRS}	Output Signal Crossover		1.3	2.0	V
V _{IN}	Input Capacitance			20	pF

Table 30. PA and PD

Symbol	Parameter	Condition	Min	Max	Unit
V _{OL2}	Output Low Level, PA and PD	IOL = 2 mA		0.5	V
V _{OH2}	Output High Level	IOH = 2mA	VCEXT - 0.4		V
V _{IL2}	Input Low Level		-0.3	0.3 VCEXT	V
V _{IH2}	Input High Level		0.7 VCEXT	VCEXT + 0.3	V
RPU	PC Pull-up resistor current	V = 0	90	280	μA
C	Input/Output capacitance	1 MHz		10	pF

Note: VCEXT is the voltage of CEXT1, CEXT2 and CEXTA.

Table 31. Oscillator Signals: XTAL1, XTAL2

Symbol	Parameter	Condition	Min	Max	Unit
V _{LH}	OSC1 switching level		0.47	1.20	V
V _{HL}	OSC1 switching level		0.67	1.44	V
CX1	Input capacitance, XTAL1			10	pF
CX2	Output capacitance, XTAL2			10	pF
C12	OSC1/2 capacitance			5	pF
t _{SU}	Start-up time	6 MHz, fundamental		2	ms
DL	Drive level			50	μW

Note: XTAL2 must not be used to drive other circuitry.

Table 32. USB Driver Characteristics, Full Speed Operation

Symbol	Parameter	Condition	Min	Max	Unit
TR	Rise time	C _L = 50 pF	4	20	ns
TF	Fall time	C _L = 50 pF	4	20	ns
TRFM	TR/TF matching		90	110	%
ZDRV	Driver output resistance ⁽¹⁾	Steady state drive	28	44	Ω

Note: 1. With external 27Ω series resistor.

Figure 21. Full-speed Load

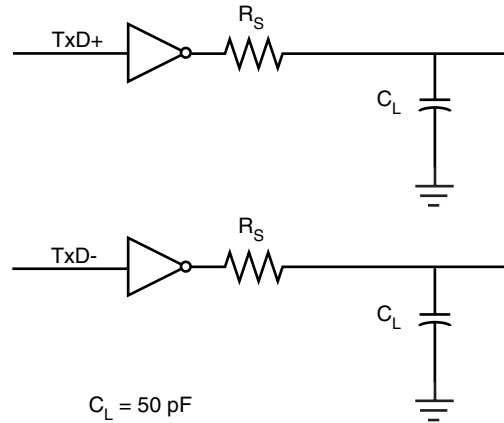

Table 33. USB Driver Characteristics, Low-speed Operation

Symbol	Parameter	Condition	Min	Max	Unit
TR	Rise time	$C_L = 200 - 600 \text{ pF}$	75	300	ns
TF	Fall time	$C_L = 200 - 600 \text{ pF}$	75	300	ns
TRFM	TR/TF matching		80	125	%

Figure 22. Low-speed Downstream Port Load

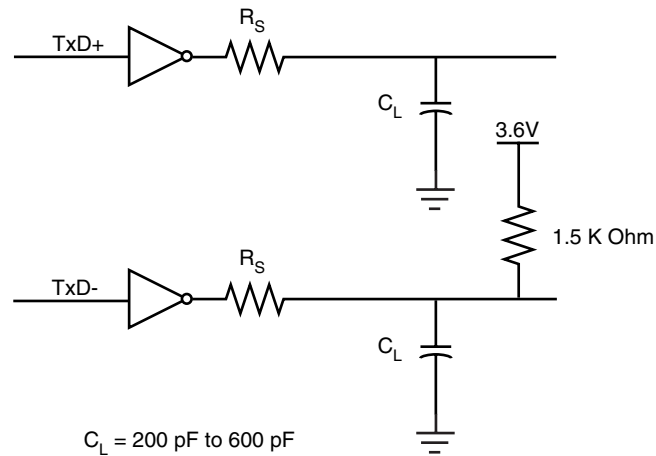

Table 34. USB Source Timings, Full-speed Operation

Symbol	Parameter	Condition	Min	Max	Unit
TDRATE	Full Speed Data Rate ⁽¹⁾	Average Bit Rate	11.97	12.03	Mb/s
TFRAME	Frame Interval ⁽¹⁾		0.9995	1.0005	ms
TRFI	Consecutive Frame Interval Jitter ⁽¹⁾	No clock adjustment		42	ns
TRFIADJ	Consecutive Frame Interval Jitter ⁽¹⁾	With clock adjustment		126	ns
TDJ1	Source Diff Driver Jitter To Next Transition		-3.5	3.5	ns
TDJ2	For Paired Transitions		-4	4	
TFDEOP	Source Jitter for Differential Transition to SEO Transitions		-2	5	ns
TDEOP	Differential to EOP Transition Skew		-2	5	ns
TJR1	Receiver Data Jitter Tolerance To Next Transition		-18.5	18.5	ns
TJR2	For Paired Transitions		-9	9	
TFEOPT	Source SEO interval of EOP		160	175	ns
TFEOPR	Receiver SEO interval of EOP		82		ns
TFST	Width of SEO interval during differential transition			14	ns

Note: 1. With 6.000 MHz, 100 ppm crystal.

Figure 23. Differential Data Jitter

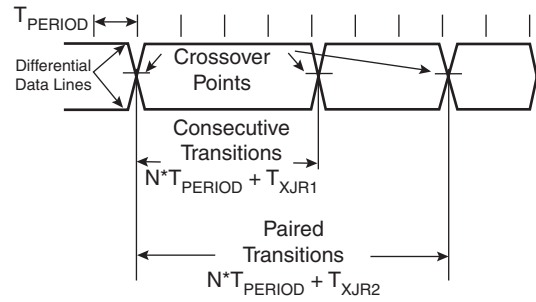

Figure 24. Differential-to-EOP Transition Skew and EOP Width

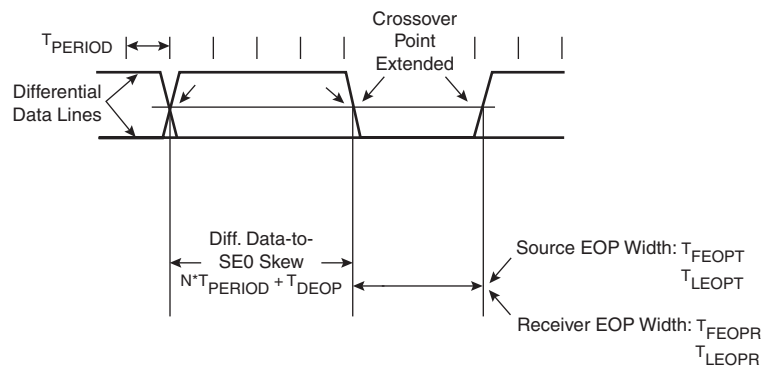

Figure 25. Receiver Jitter Tolerance

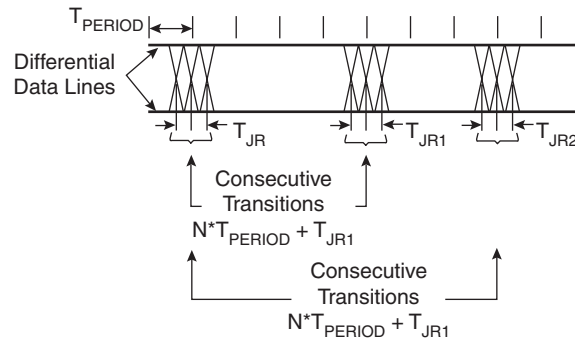

Table 35. Hub Timings, Full-speed Operation

Symbol	Parameter	Condition	Min	Max	Unit
THDD2	Hub Differential Data Delay without cable			44	ns
THDJ1	Hub Diff Driver Jitter To Next Transition		-3	3	ns
THDJ2	For Paired Transitions		-1	1	
TFSOP	Data Bit Width Distortion after SOP		-5	5	ns
TFEOPD	Hub EOP Delay Relative to THDD		0	15	ns
TFHESK	Hub EOP Output Width Skew		-15	15	ns

Table 36. Hub Timings, Low-speed Operation

Symbol	Parameter	Condition	Min	Max	Unit
TLHDD	Hub Differential Data Delay			300	ns
TLHDJ1	Downstr Hub Diff Driver Jitter to Next Transition, Downst for Paired Transitions,		-45	45	ns
TLHDJ2	Downst to Next Transition,		-15	15	
TLUHJ1	Upstr for Paired Transitions,		-45	45	
TLUHJ2	Upstr		-45	45	
TSOP	Data Bit Width Distortion after SOP		-60	60	ns
TLEOPD	Hub EOP Delay Relative to THDD		0	200	ns
TLHESK	Hub EOP Output Width Skew		-300	300	ns

Table 37. Hub Event Timings

Symbol	Parameter	Condition	Min	Max	Unit
TDCNN	Time to detect a downstream port connect event		2.5	2000	μs
TDDIS	Time to detect a disconnect event on downstream port Awake Hub Suspended Hub		2.5 2.5	2000 12000	μs
TURSM	Time from detecting downstream resume to rebroadcast			100	μs
TDRST	Duration of driving reset to a downstream device	Only for a SetPortFeature (PORT_RESET) request	10	20	μs
TDSPDEV	Time to evaluate device speed after reset		2.5	1000	μs
TURLK	Time to detect a long K from upstream		2.5	5.5	μs
TURLSEO	Time to detect a long SEO from upstream		2.5	5.5	μs
TURPSEO	Duration of repeating SEO upstream			23	FS bits
TUDEOP	Duration of sending SEO upstream after EOF1			2	FS bits

Figure 26. Hub Differential Delay, Differential Jitter and SOP Distortion

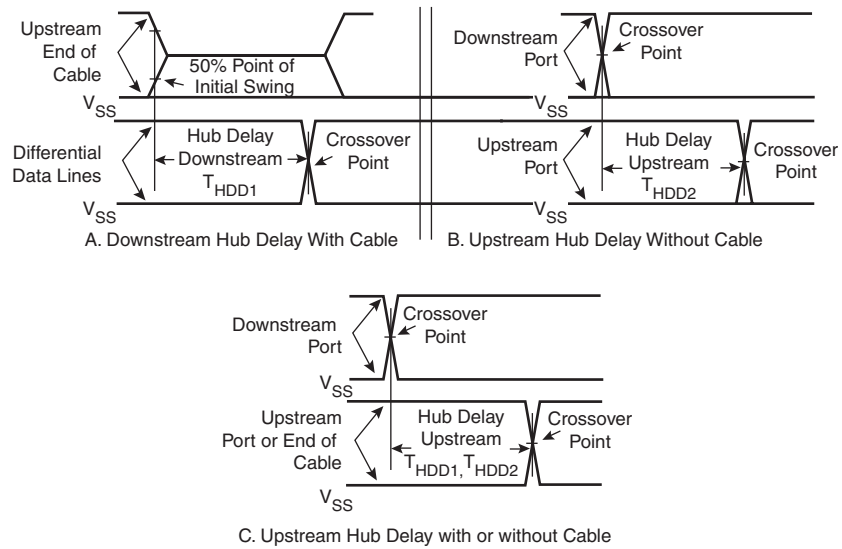
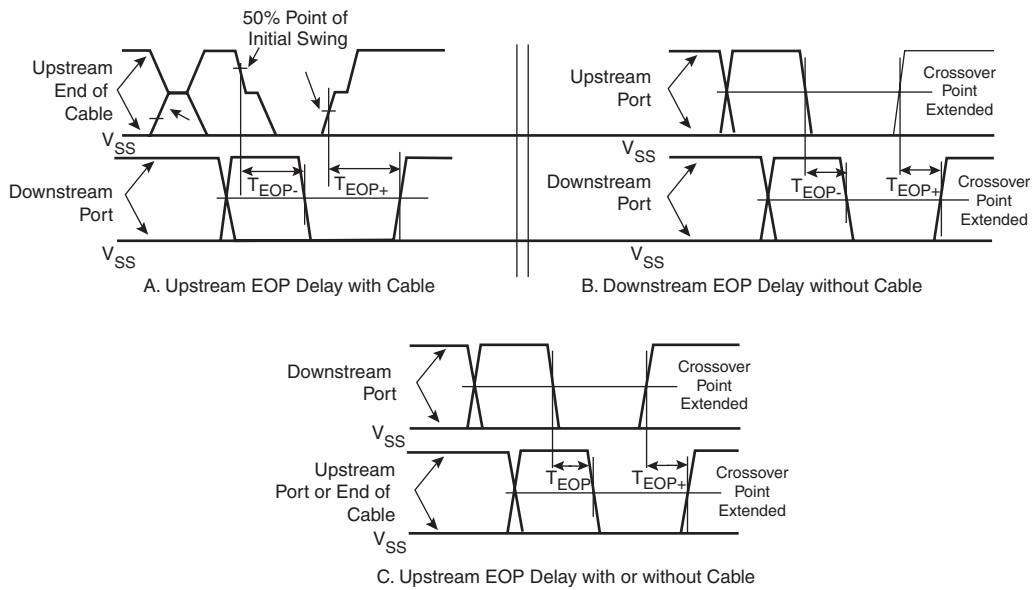

Figure 27. Hub EOP Delay and EOP Skew



Ordering Information

Program Memory	Ordering Code	Package	Operation Range
Mask ROM	AT43USB353M-AC	48 LQFP	Commercial (0°C to 70°C)

Packaging Information

48AA – LQFP

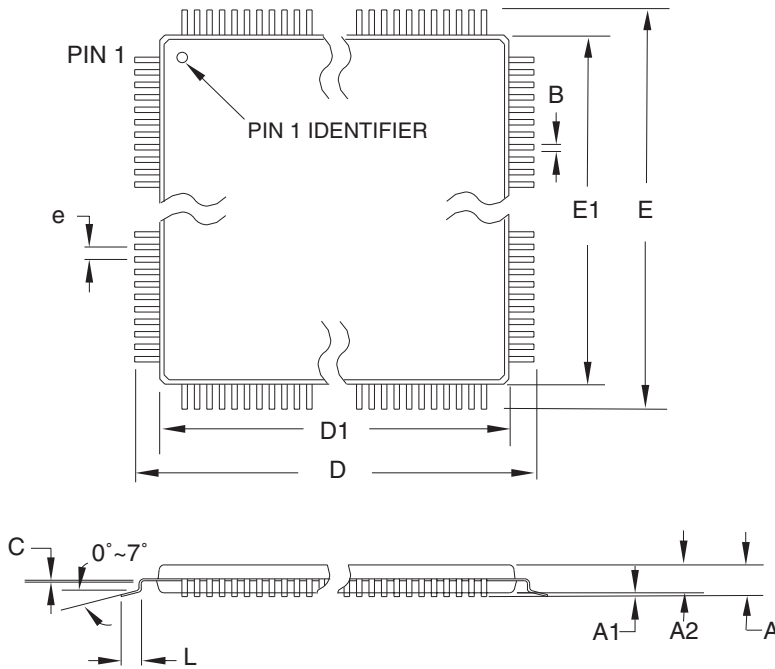

COMMON DIMENSIONS
(Unit of Measure = mm)

SYMBOL	MIN	NOM	MAX	NOTE
A	–	–	1.60	
A1	0.05	–	0.15	
A2	1.35	1.40	1.45	
D	8.75	9.00	9.25	
D1	6.90	7.00	7.10	Note 2
E	8.75	9.00	9.25	
E1	6.90	7.00	7.10	Note 2
B	0.17	–	0.27	
C	0.09	–	0.20	
L	0.45	–	0.75	
e	0.50 TYP			

- Notes:
1. This package conforms to JEDEC reference MS-026, Variation BBC.
 2. Dimensions D1 and E1 do not include mold protrusion. Allowable protrusion is 0.25 mm per side. Dimensions D1 and E1 are maximum plastic body size dimensions including mold mismatch.
 3. Lead coplanarity is 0.08 mm maximum.

10/5/2001

2325 Orchard Parkway San Jose, CA 95131	TITLE	DRAWING NO.	REV.
	48AA , 48-lead, 7 x 7 mm Body Size, 1.4 mm Body Thickness, 0.5 mm Lead Pitch, Low Profile Plastic Quad Flat Package (LQFP)	48AA	C



Change Log

Doc. Rev.	Comments
3302D	<ul style="list-style-type: none">• Data Correction: timeout period data in Table 20 on page 46.• Additions: Added an “Errata Sheet” on page 93 and a “Change Log” on page 94.





Atmel Corporation

2325 Orchard Parkway
San Jose, CA 95131, USA
Tel: 1(408) 441-0311
Fax: 1(408) 487-2600

Regional Headquarters

Europe

Atmel Sarl
Route des Arsenaux 41
Case Postale 80
CH-1705 Fribourg
Switzerland
Tel: (41) 26-426-5555
Fax: (41) 26-426-5500

Asia

Room 1219
Chinachem Golden Plaza
77 Mody Road Tsimshatsui
East Kowloon
Hong Kong
Tel: (852) 2721-9778
Fax: (852) 2722-1369

Japan

9F, Tonetsu Shinkawa Bldg.
1-24-8 Shinkawa
Chuo-ku, Tokyo 104-0033
Japan
Tel: (81) 3-3523-3551
Fax: (81) 3-3523-7581

Atmel Operations

Memory

2325 Orchard Parkway
San Jose, CA 95131, USA
Tel: 1(408) 441-0311
Fax: 1(408) 436-4314

Microcontrollers

2325 Orchard Parkway
San Jose, CA 95131, USA
Tel: 1(408) 441-0311
Fax: 1(408) 436-4314

La Chantrerie
BP 70602
44306 Nantes Cedex 3, France
Tel: (33) 2-40-18-18-18
Fax: (33) 2-40-18-19-60

ASIC/ASSP/Smart Cards

Zone Industrielle
13106 Rousset Cedex, France
Tel: (33) 4-42-53-60-00
Fax: (33) 4-42-53-60-01

1150 East Cheyenne Mtn. Blvd.
Colorado Springs, CO 80906, USA
Tel: 1(719) 576-3300
Fax: 1(719) 540-1759

Scottish Enterprise Technology Park
Maxwell Building
East Kilbride G75 0QR, Scotland
Tel: (44) 1355-803-000
Fax: (44) 1355-242-743

RF/Automotive

Theresienstrasse 2
Postfach 3535
74025 Heilbronn, Germany
Tel: (49) 71-31-67-0
Fax: (49) 71-31-67-2340

1150 East Cheyenne Mtn. Blvd.
Colorado Springs, CO 80906, USA
Tel: 1(719) 576-3300
Fax: 1(719) 540-1759

Biometrics/Imaging/Hi-Rel MPU/ High Speed Converters/RF Datacom

Avenue de Rochepleine
BP 123
38521 Saint-Egreve Cedex, France
Tel: (33) 4-76-58-30-00
Fax: (33) 4-76-58-34-80

Literature Requests

www.atmel.com/literature

Disclaimer: Atmel Corporation makes no warranty for the use of its products, other than those expressly contained in the Company's standard warranty which is detailed in Atmel's Terms and Conditions located on the Company's web site. The Company assumes no responsibility for any errors which may appear in this document, reserves the right to change devices or specifications detailed herein at any time without notice, and does not make any commitment to update the information contained herein. No licenses to patents or other intellectual property of Atmel are granted by the Company in connection with the sale of Atmel products, expressly or by implication. Atmel's products are not authorized for use as critical components in life support devices or systems.

© Atmel Corporation 2004. All rights reserved. Atmel® and combinations thereof, and AVR® are the registered trademarks of Atmel Corporation or its subsidiaries. Other terms and product names may be the trademarks of others.



Printed on recycled paper.

3307B-USB-4/04

xM