

**3-TERMINAL ADJUSTABLE REGULATOR****AZ317L****General Description**

The AZ317L is an adjustable 3-terminal positive voltage regulator capable of supplying 100mA over a 1.2V to 12V output range. This voltage regulator is exceptionally easy to use and requires only two external resistors to set the output voltage. Both line and load regulation are better than standard fixed regulators.

In addition to higher performance than fixed regulators, AZ317L employs overload protection. Included on the chip are current limiting and thermal overload protection. All overload protection circuitry remains fully functional even when the adjustment terminal is disconnected.

The AZ317L is available in standard TO-92 and SOIC-8 packages.

**Features**

- Adjustable Output Down to 1.2V
- Guaranteed 100mA Output Current
- Output Short Circuit Protected
- Line Regulation: 0.01%/V
- Load Regulation: 0.1%
- Current Limit Constant with Temperature
- Standard 3-lead Transistor Package
- 70 dB Ripple Rejection

**Applications**

- High Efficiency Linear Regulators
- Post Regulation for Switching Supplies
- Microprocessor Power Supply
- Mother Board I/O Power Supply

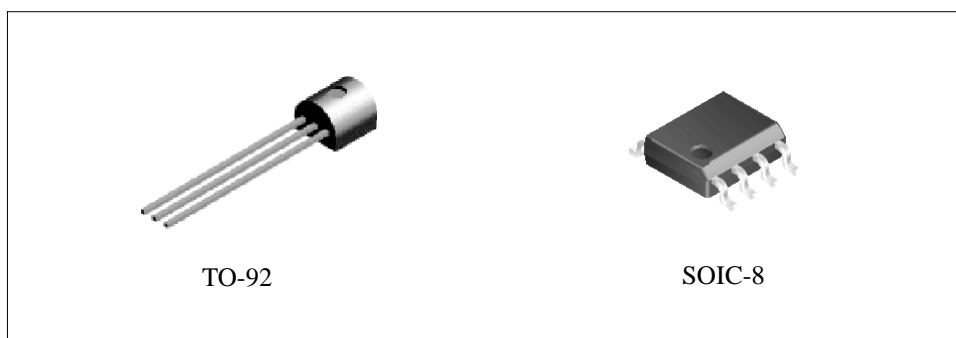

Figure 1. Package Types of AZ317L



# 3-TERMINAL ADJUSTABLE REGULATOR

# AZ317L

## Pin Configuration

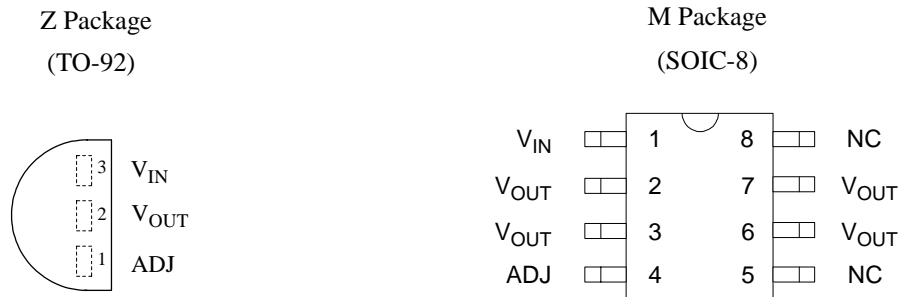

Top View

Figure 2. Pin Configuration of AZ317L

## Functional Block Diagram

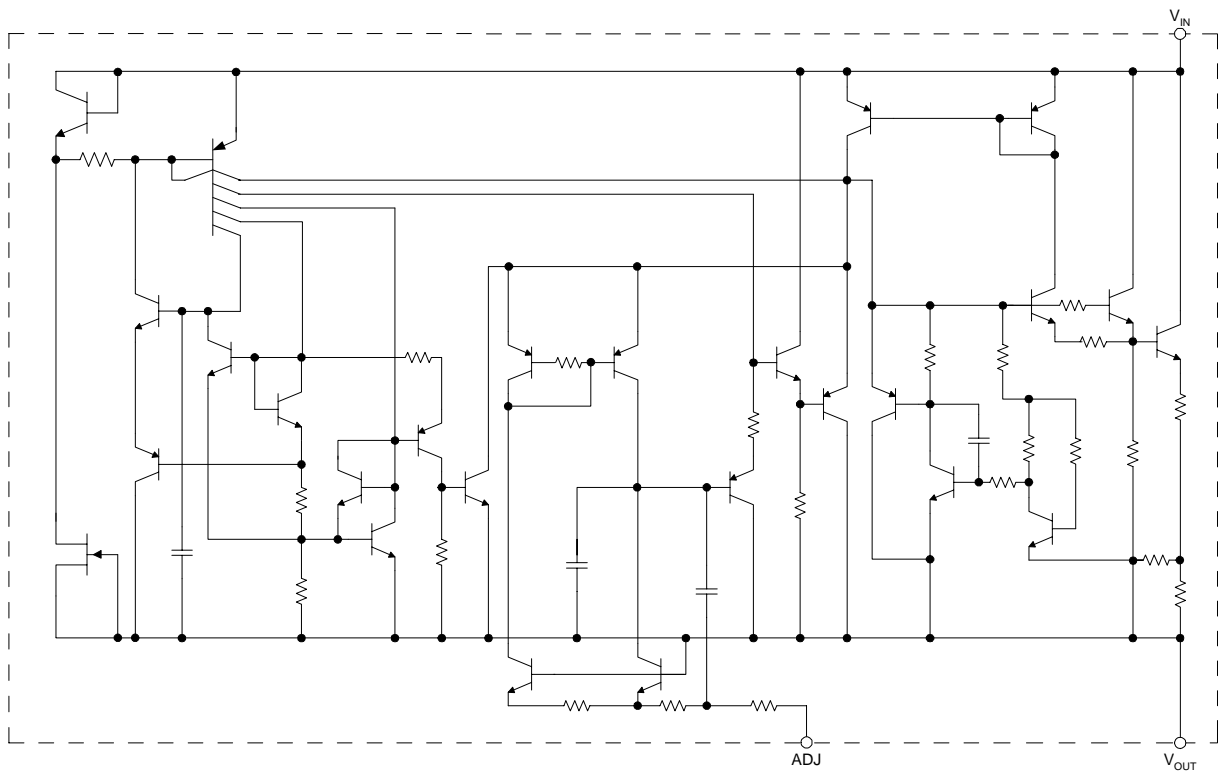

Figure 3. Functional Block Diagram of AZ317L



**3-TERMINAL ADJUSTABLE REGULATOR**

**AZ317L**

**Ordering Information**

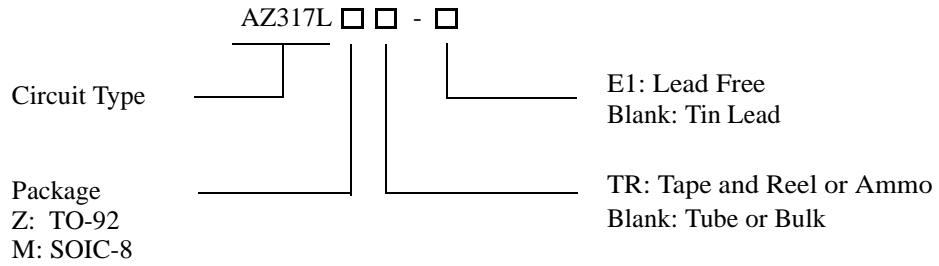

Package	Temperature Range	Part Number		Marking ID		Packing Type
		Tin Lead	Lead Free	Tin Lead	Lead Free	
TO-92	0 to 125°C	AZ317LZ	AZ317LZ-E1	AZ317LZ	AZ317LZ-E1	Bulk
		AZ317LZTR	AZ317LZTR-E1	AZ317LZ	AZ317LZ-E1	Ammo
SOIC-8	0 to 125°C	AZ317LM	AZ317LM-E1	317LM	317LM-E1	Tube
		AZ317LMTR	AZ317LMTR-E1	317LM	317LM-E1	Tape & Reel

BCD Semiconductor's Pb-free products, as designated with "E1" suffix in the part number, are RoHS compliant.

**3-TERMINAL ADJUSTABLE REGULATOR****AZ317L****Absolute Maximum Ratings (Note 1)**

Parameter	Symbol	Value	Unit
Input Voltage	$V_{IN}$	20	V
Input-Output Voltage Differential		15	V
Operating Junction Temperature Range	$T_J$	150	°C
Storage Temperature Range	$T_{STG}$	-65 to 150	°C
Power Dissipation	$P_D$	700	mW
Lead Temperature (Soldering, 4 sec.)	$T_{LEAD}$	260	°C
ESD (Machine Model)	ESD	250	V

Note 1: Stresses greater than those listed under "Absolute Maximum Ratings" may cause permanent damage to the device. These are stress ratings only, and functional operation of the device at these or any other conditions beyond those indicated under "Recommended Operating Conditions" is not implied. Exposure to "Absolute Maximum Ratings" for extended periods may affect device reliability.

**Recommended Operating Conditions**

Parameter	Symbol	Min	Max	Unit
Input Voltage	$V_{IN}$		15	V
Operating Junction Temperature Range	$T_J$	0	125	°C



**3-TERMINAL ADJUSTABLE REGULATOR**

**AZ317L**

**Electrical Characteristics**

$0^{\circ}\text{C} \leq T_J \leq 125^{\circ}\text{C}$ ,  $V_{\text{IN}} - V_{\text{OUT}} = 5\text{V}$ ,  $I_{\text{OUT}} = 40\text{mA}$ ,  $P_D \leq 625\text{mW}$ , unless otherwise specified.

Parameter	Symbol	Conditions	Min	Typ	Max	Unit
Line Regulation	Reg <sub>LINE</sub>	$T_J = 25^{\circ}\text{C}$ , $3\text{V} \leq (V_{\text{IN}} - V_{\text{OUT}}) \leq 15\text{V}$ $I_L \leq 20\text{mA}$ (Note 2)		0.01	0.04	%/V
		$3\text{V} \leq (V_{\text{IN}} - V_{\text{OUT}}) \leq 15\text{V}$ , $I_L \leq 20\text{mA}$ (Note 2)		0.02	0.07	%/V
Load Regulation	Reg <sub>LOAD</sub>	$T_J = 25^{\circ}\text{C}$ , $5\text{mA} \leq I_{\text{OUT}} \leq 100\text{mA}$ (Note 2)		0.1	0.5	%
		$5\text{mA} \leq I_{\text{OUT}} \leq 100\text{mA}$ (Note 2)		0.3	1.5	%
Thermal Regulation		$T_J = 25^{\circ}\text{C}$ , 10ms Pulse		0.04	0.2	%/W
Adjust Pin Current				50	100	$\mu\text{A}$
Adjust Pin Current Change		$5\text{mA} \leq I_L \leq 100\text{mA}$ $3\text{V} \leq (V_{\text{IN}} - V_{\text{OUT}}) \leq 15\text{V}$		0.2	5	$\mu\text{A}$
Reference Voltage	$V_{\text{REF}}$	$3\text{V} \leq (V_{\text{IN}} - V_{\text{OUT}}) \leq 15\text{V}$ $5\text{mA} \leq I_{\text{OUT}} \leq 100\text{mA}$	1.20	1.25	1.30	V
Current Limit	$I_{\text{LIMIT}}$	$3\text{V} \leq (V_{\text{IN}} - V_{\text{OUT}}) \leq 13\text{V}$	100	200	300	mA
Minimum Load Current		$3\text{V} \leq (V_{\text{IN}} - V_{\text{OUT}}) \leq 13\text{V}$		3.5	5	mA
Ripple Rejection		$V_{\text{OUT}} = 10\text{V}$ , $f = 120\text{Hz}$ , $C_{\text{ADJ}} = 0\mu\text{F}$		62		dB
		$V_{\text{OUT}} = 10\text{V}$ , $f = 120\text{Hz}$ , $C_{\text{ADJ}} = 10\mu\text{F}$	60	70		
Temperature Stability		$0^{\circ}\text{C} \leq T_J \leq 125^{\circ}\text{C}$		0.65		%
Long Term Stability		$T_J = 125^{\circ}\text{C}$ , 1000 Hours		0.3	1	%
RMS Output Noise, % of $V_{\text{OUT}}$		$T_J = 25^{\circ}\text{C}$ , $10\text{Hz} \leq f \leq 10\text{KHz}$		0.003		%
Thermal Resistance Junction to Case		TO-92		185		$^{\circ}\text{C}/\text{W}$
		SOIC-8		175		

Note 2: Regulation is measured at constant junction temperature, using pulse testing with a low duty cycle. Changes in output voltage due to heating effects are covered under the specification of thermal regulation.



### 3-TERMINAL ADJUSTABLE REGULATOR

AZ317L

#### Typical Performance Characteristics

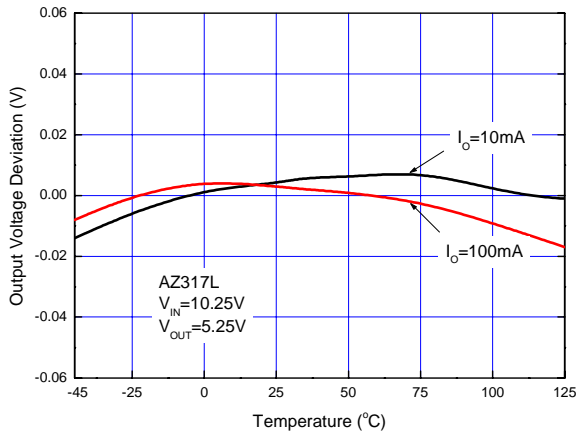

Figure 4. Load Regulation vs. Temperature

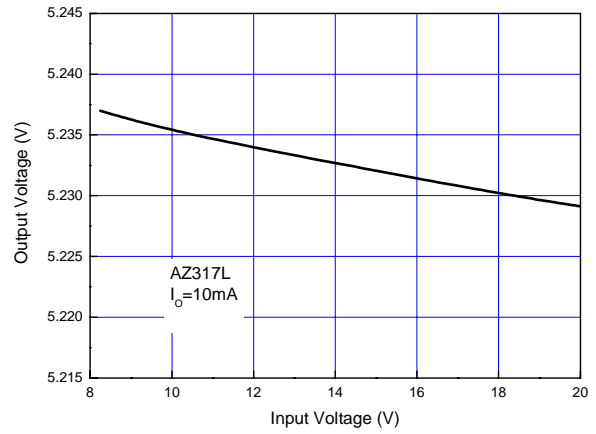

Figure 5. Output Voltage vs. Input Voltage

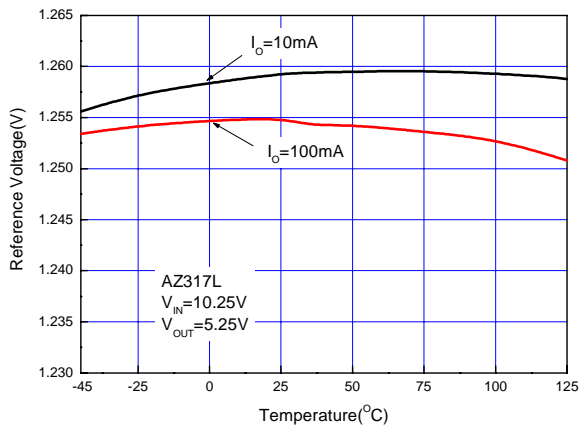

Figure 6. Reference Voltage vs. Temperature

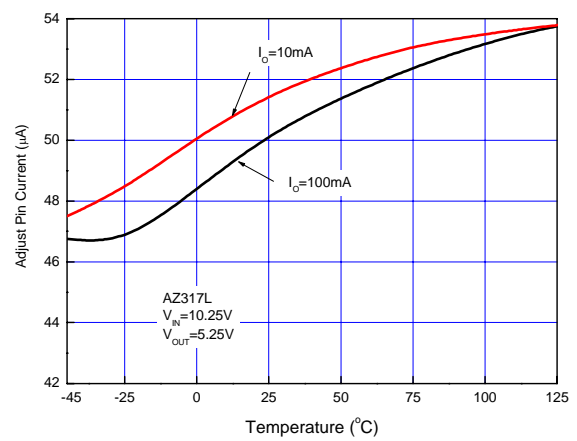

Figure 7. Adjustment Current vs. Temperature



### 3-TERMINAL ADJUSTABLE REGULATOR

AZ317L

#### Typical Performance Characteristics (Continued)

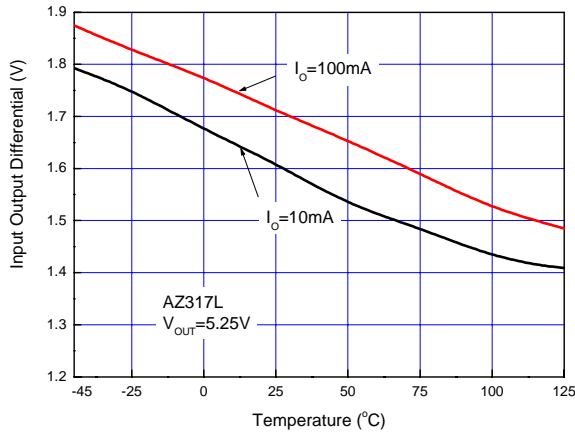

Figure 8. Dropout Voltage vs. Temperature

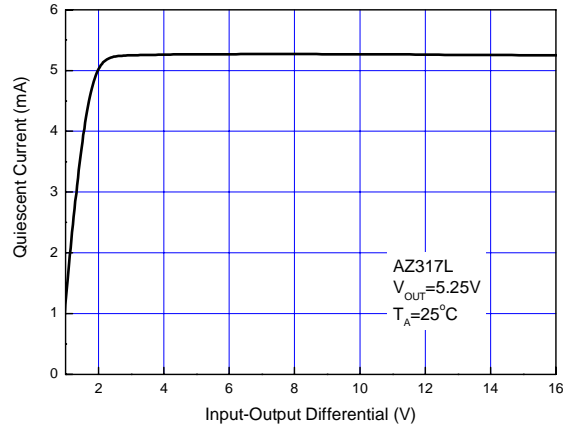

Figure 9. Minimum Operating Current

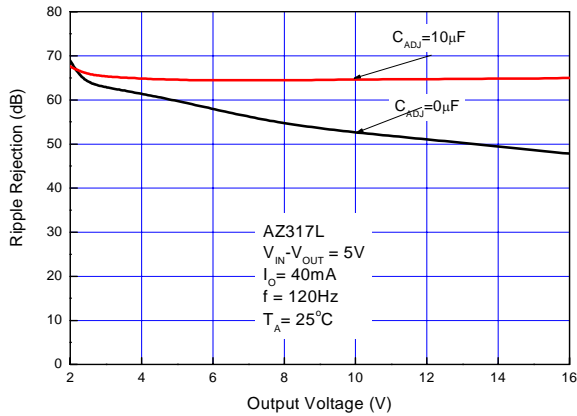

Figure 10. Ripple Rejection vs. Output Voltage

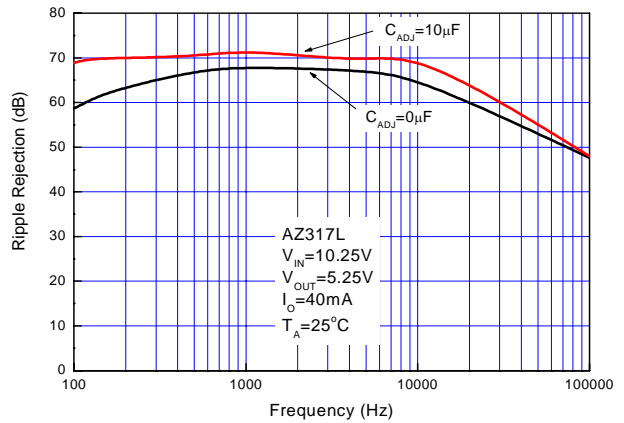

Figure 11. Ripple Rejection vs. Frequency



### 3-TERMINAL ADJUSTABLE REGULATOR

### AZ317L

#### Typical Performance Characteristics (Continued)

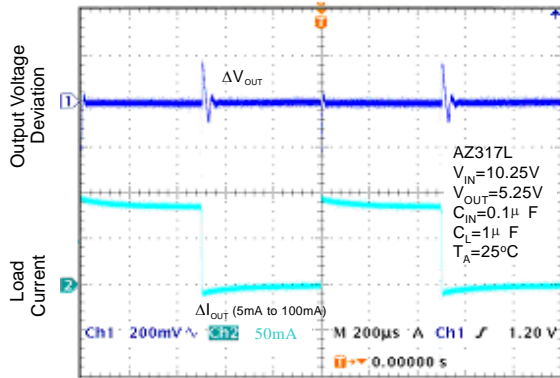

Figure 12. Load Transient Response

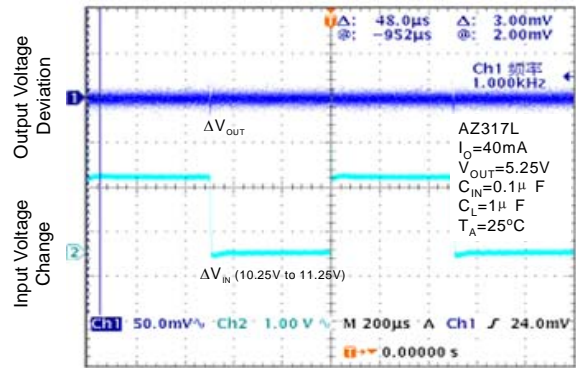

Figure 13. Line Transient Response

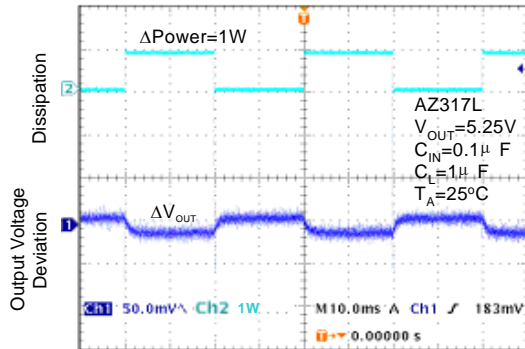

Figure 14. Thermal Regulation





**3-TERMINAL ADJUSTABLE REGULATOR**

**AZ317L**

**Typical Application**

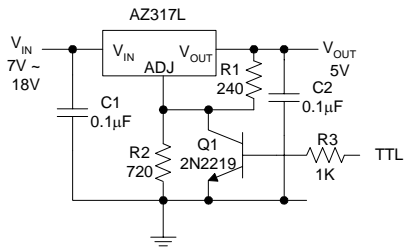

Figure 15. 5V Logic Regulator with Electronic Shutdown (Minimum output = 1.2V)

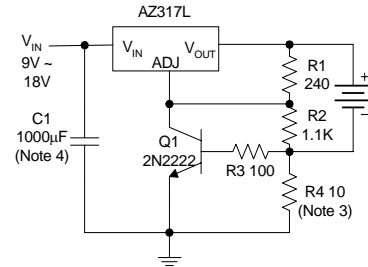

Figure 16. Current Limited 6V Charger  
 Note 3: Sets peak current,  $I_{peak} = 0.6V/R4$   
 Note 4: 1000µF is recommended to filter out any input transients.

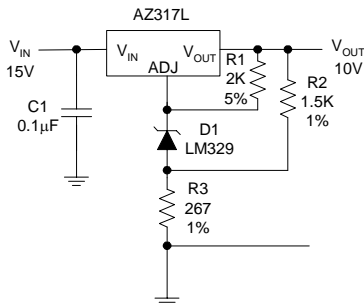

Figure 17. High Stability 10V Regulator

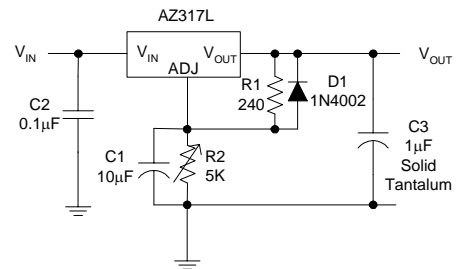

Figure 18. Adjustable Regulator with Improved Ripple Rejection  
 Note 5: Discharge C1 if output is shorted to ground.



**3-TERMINAL ADJUSTABLE REGULATOR**

**AZ317L**

**Typical Application (Continued)**

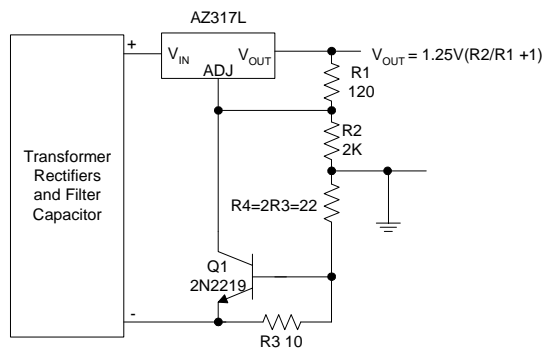

Figure 19. Adjustable Regulator with Current Limit  
Note 6: Short circuit current is approximately  $600\text{mV}/R3$  or  $60\text{mA}$   
Note 7: At  $2.5\text{mA}$  output only  $3/4\text{V}$  of drop occurs in  $R3$  and  $R4$ .

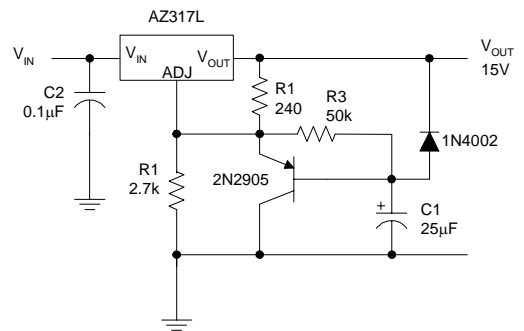

Figure 20. Slow Turn-on 15V Regulator



**3-TERMINAL ADJUSTABLE REGULATOR**

**AZ317L**

**Mechanical Dimensions**

**TO-92**

**Unit: mm(inch)**

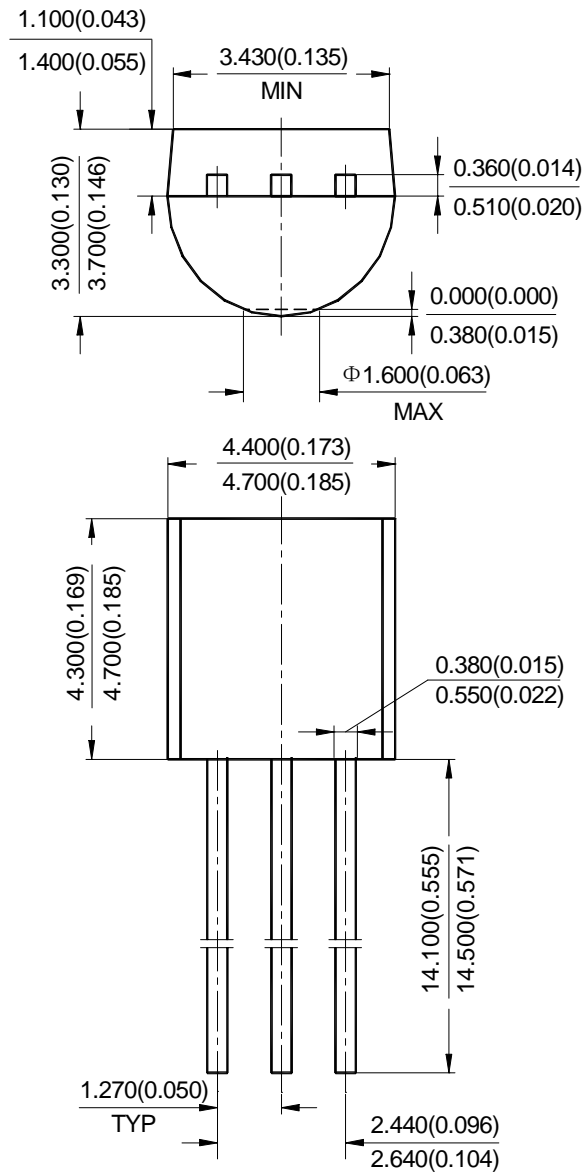



**3-TERMINAL ADJUSTABLE REGULATOR**

**AZ317L**

**Mechanical Dimensions (Continued)**

**SOIC-8**

**Unit: mm(inch)**

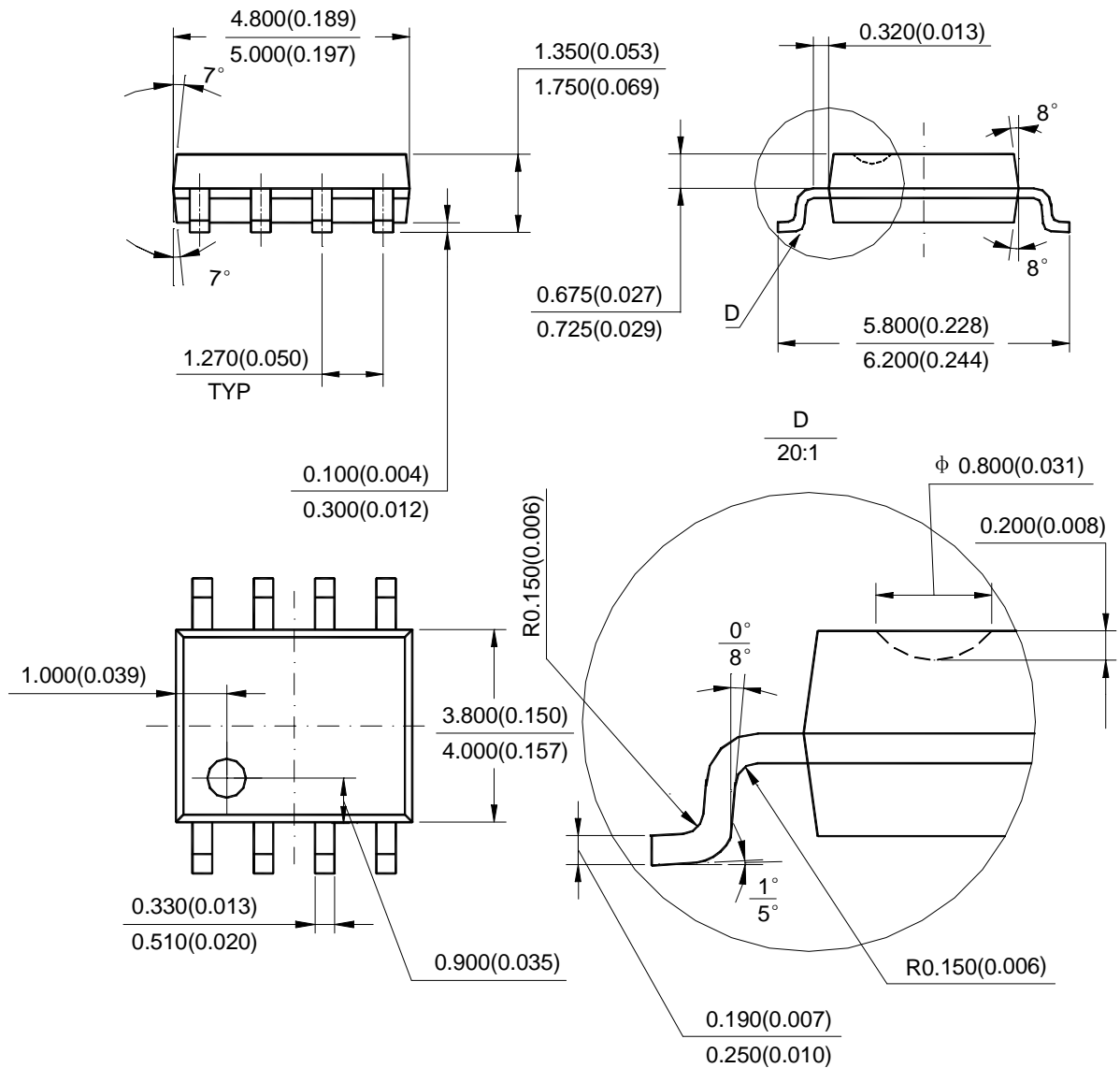



BCD Semiconductor Manufacturing Limited

<http://www.bcdsemi.com>

---

**BCD Semiconductor Corporation**

3170 De La Cruz Blvd, Suite # 105 Santa Clara, CA 95054-2411, U.S.A

Tel: +1-408-988 6388, Fax: +1-408-988 6386

**Shanghai SIM-BCD Semiconductor Manufacturing Co., Ltd.**

800 Yi Shan Road, Shanghai 200233, PRC

Tel: +86-21-6485 1491, Fax: +86-21-5450 0008

**Advanced Analog Circuits (Shanghai) Corporation**

8F, B Zone, 900 Yi Shan Road, Shanghai 200233, PRC

Tel: +86-21-6495 9539, Fax: +86-21-6485 9673

**BCD Semiconductor (Taiwan) Company Limited**

4F, 298-1 Rui Guang Road, Nei-Hu District, Taipei, Taiwan

Tel: +886-2-2656-2808, Fax: +886-2-2656-2806

**IMPORTANT NOTICE**

BCD Semiconductor Manufacturing Limited reserves the right to make changes without further notice to any products or specifications herein. BCD Semiconductor Manufacturing Limited does not assume any responsibility for use of any its products for any particular purpose, nor does BCD Semiconductor Manufacturing Limited assume any liability arising out of the application or use of any its products or circuits. BCD Semiconductor Manufacturing Limited does not convey any license under its patent rights or other rights nor the rights of others.