

Single/Dual Single-Wire Temp Sensor in SOT23-5 Using SMSC BudgetBus™ Sensor Interface

PRODUCT FEATURES

Datasheet

General Description

The EMC1201 and EMC1202 are temperature sensors that communicate with a host over a single-wire SMSC BudgetBus™ Sensor Interface. The EMC1201 has an internal temperature sensor and the EMC1202 adds one remote diode. Packaged in a SOT23-5, the EMC1201 provides an accurate, low-cost, low-current, solution for critical temperature monitoring in applications such as embedded systems or computers. When used in combination with an SMSC Super I/O host, such as a keyboard controller, a complete thermal management system is created. A power down mode extends battery life in portable applications. The internal 11-bit sigma delta temperature-to-digital converter provides superb linearity, high accuracy and excellent noise immunity.

PART NUMBER	INTERNAL TEMPERATURE MONITOR	EXTERNAL TEMPERATURE MONITOR
EMC1201	1	0
EMC1202	1	1

Features

- Single-wire SMSC BudgetBus™ Sensor Interface
- Low Power, 3.0V to 3.6V Supply
 - < 50uA at 1 conversion per second
 - < 3uA in Standby
- External Temperature Sensor
 - Range -63.875° C to +191.875° C
 - 0.125° C resolution
 - ±1° C Accuracy 60° C to 100° C
 - Diode Fault Reporting
- Self Contained Internal Temperature Sensor
 - Range 0° C to +85° C
 - 0.125° C resolution
 - ±3° C Accuracy 0° C to 85° C
- SOT23-5 Green, Lead-free Packages

Applications

- Desktop and Notebook Computers
- Thermostats
- Smart batteries
- Industrial/Automotive
- Other Electronic Systems

Simplified Block Diagram

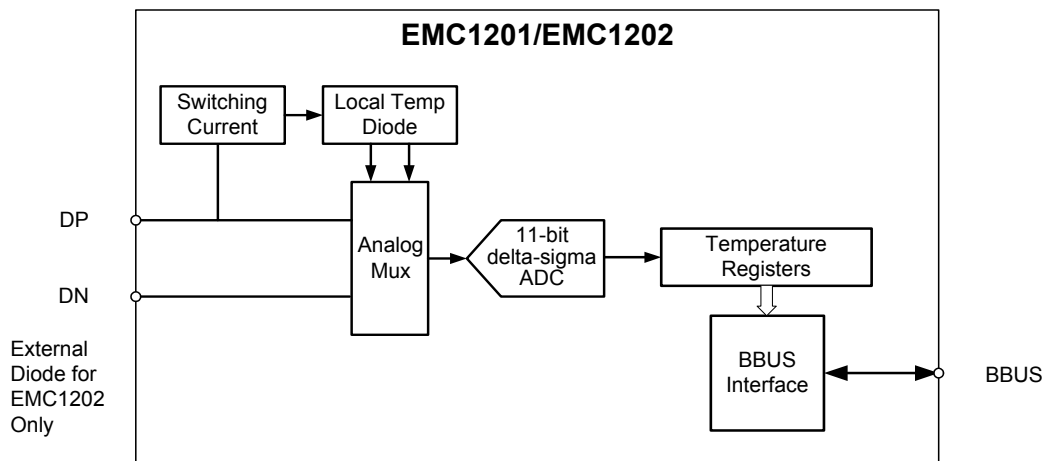

ORDER NUMBER(S):**EMC1201-AGZQ-TR IN 5 PIN SOT23-5 PACKAGE (GREEN, LEAD-FREE)****EMC1202-AGZQ-TR IN 5 PIN SOT23-5 PACKAGE (GREEN, LEAD-FREE)**

80 ARKAY DRIVE, HAUPPAUGE, NY 11788 (631) 435-6000, FAX (631) 273-3123

Copyright © 2006 SMSC or its subsidiaries. All rights reserved.

Circuit diagrams and other information relating to SMSC products are included as a means of illustrating typical applications. Consequently, complete information sufficient for construction purposes is not necessarily given. Although the information has been checked and is believed to be accurate, no responsibility is assumed for inaccuracies. SMSC reserves the right to make changes to specifications and product descriptions at any time without notice. Contact your local SMSC sales office to obtain the latest specifications before placing your product order. The provision of this information does not convey to the purchaser of the described semiconductor devices any licenses under any patent rights or other intellectual property rights of SMSC or others. All sales are expressly conditional on your agreement to the terms and conditions of the most recently dated version of SMSC's standard Terms of Sale Agreement dated before the date of your order (the "Terms of Sale Agreement"). The product may contain design defects or errors known as anomalies which may cause the product's functions to deviate from published specifications. Anomaly sheets are available upon request. SMSC products are not designed, intended, authorized or warranted for use in any life support or other application where product failure could cause or contribute to personal injury or severe property damage. Any and all such uses without prior written approval of an Officer of SMSC and further testing and/or modification will be fully at the risk of the customer. Copies of this document or other SMSC literature, as well as the Terms of Sale Agreement, may be obtained by visiting SMSC's website at <http://www.smsc.com>. SMSC is a registered trademark of Standard Microsystems Corporation ("SMSC"). Product names and company names are the trademarks of their respective holders.

SMSC DISCLAIMS AND EXCLUDES ANY AND ALL WARRANTIES, INCLUDING WITHOUT LIMITATION ANY AND ALL IMPLIED WARRANTIES OF MERCHANTABILITY, FITNESS FOR A PARTICULAR PURPOSE, TITLE, AND AGAINST INFRINGEMENT AND THE LIKE, AND ANY AND ALL WARRANTIES ARISING FROM ANY COURSE OF DEALING OR USAGE OF TRADE. IN NO EVENT SHALL SMSC BE LIABLE FOR ANY DIRECT, INCIDENTAL, INDIRECT, SPECIAL, PUNITIVE, OR CONSEQUENTIAL DAMAGES; OR FOR LOST DATA, PROFITS, SAVINGS OR REVENUES OF ANY KIND; REGARDLESS OF THE FORM OF ACTION, WHETHER BASED ON CONTRACT; TORT; NEGLIGENCE OF SMSC OR OTHERS; STRICT LIABILITY; BREACH OF WARRANTY; OR OTHERWISE; WHETHER OR NOT ANY REMEDY OF BUYER IS HELD TO HAVE FAILED OF ITS ESSENTIAL PURPOSE, AND WHETHER OR NOT SMSC HAS BEEN ADVISED OF THE POSSIBILITY OF SUCH DAMAGES.

Datasheet

Chapter 1 Pin Configuration

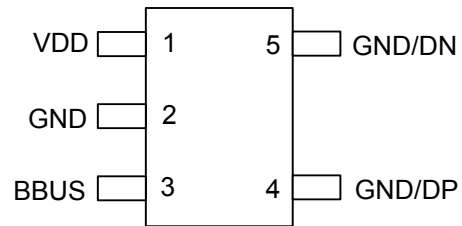

Figure 1.1 EMC1201 and EMC1202 Pin Configuration

1.1 Pin Description

Table 1.1 EMC1201 and EMC1202 Pin Description

PIN	PIN NO.	DESCRIPTION
VDD	1	Supply Voltage V_{DD}
GND	2	Ground
BBUS	3	Serial Bus Interface to SMSC Host
GND/DP	4	Ground, or Diode 1 Positive Terminal, EMC1202 only
GND/DN	5	Ground, or Diode 1 Negative Terminal, EMC1202 only

1.2 Absolute Maximum Ratings

Table 1.2 EMC1201/EMC1202 Maximum Ratings

DESCRIPTION	RATING	UNIT
Supply Voltage V_{DD}	-0.3 to 5.0	V
Voltage on any other pin	-0.3 to $V_{DD} + 0.3$	V
Operating Temperature Range	0 to 85	°C
Storage Temperature Range	-55 to 150	°C
Lead Temperature Range	Refer to JEDEC Spec. J-STD-020	
Package Thermal Characteristics for SOT23-5		
Power Dissipation	TBD	
Thermal Resistance(at 0 air flow)	131.7	°C/W
ESD Rating, All Pins Human Body Model	2000	V

Note: Stresses above those listed could cause damage to the device. This is a stress rating only and functional operation of the device at any other condition above those indicated in the operation sections of this specification is not implied. When powering this device from laboratory or system power supplies, it is important that the Absolute Maximum Ratings not be exceeded or device failure can result. Some power supplies exhibit voltage spikes on their outputs when the AC power is switched on or off. In addition, voltage transients on the AC power line may appear on the DC output. If this possibility exists, it is suggested that a clamp circuit be used.

Chapter 2 Electrical Characteristics

Table 2.1 Electrical Characteristics

V _{DD} =3.0V to 3.6V, T _A = 0°C to +85°C, Typical values at T _A = 27°C unless otherwise noted						
PARAMETER	SYMBOL	MIN	TYP	MAX	UNITS	CONDITIONS
DC Power						
Supply Voltage	V _{DD}	3.0	3.3	3.6	V	
Average Operating Current	I _{DD}		545	560	μA	Active mode (continuous)
	I _{PD}		1.8	2	μA	Standby mode
Internal Temperature Measurement						
Accuracy			±1	±3	°C	0°C ≤ T _A ≤ 85°C
External Temperature Measurement (EMC1202 only)						
Temperature Accuracy Remote Diode 60°C to 100°C Remote Diode 0°C to 125°C				± 1	°C	15°C ≤ T _A ≤ 70°C
				± 3	°C	0°C ≤ T _A ≤ 85°C
ADC						
Resolution			0.125		°C	
Conversion Time per sensor			20		ms	Active mode (continuous) See Section 3.3, "Power Modes"

Chapter 3 Product Description

The EMC1201 and EMC1202 are SOT23 temperature sensors with a proprietary single wire SMSC BudgetBus™ Sensor Interface. Temperature information is communicated to a host device via the serial bus. All intelligence regarding the interpretation of temperature resides in the host. [Figure 3.1](#) shows a typical system overview:

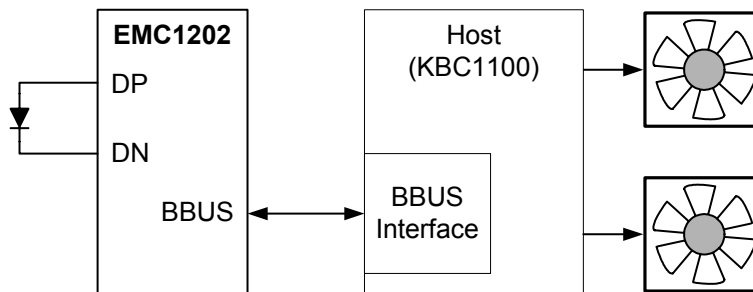

Figure 3.1 System Overview

Thermal management consists of the host acquiring the temperature data from the EMC1201 or EMC1202 and controlling the speed of one or more fans. Because the EMC1202 incorporates one internal and one external temperature diode, up to two separate thermal zones can be monitored and controlled. The host has the ability to compare measured temperature levels to preset limits and take the appropriate action when values are found to be out of limit. The EMC1202 is compatible with CPU substrate diodes.

3.1 Temperature Monitors

Thermal diode temperature measurements are based on the change in forward bias voltage (ΔV_{BE}) of a diode when operated at two different currents:

$$\Delta V_{BE} = V_{BE_HIGH} - V_{BE_LOW} = \frac{\eta k T}{q} \ln \left(\frac{I_{HIGH}}{I_{LOW}} \right)$$

where:

k = Boltzmann's constant

T = absolute temperature in Kelvin

q = electron charge

η = diode ideality factor

The change in ΔV_{BE} voltage is proportional to absolute temperature T .

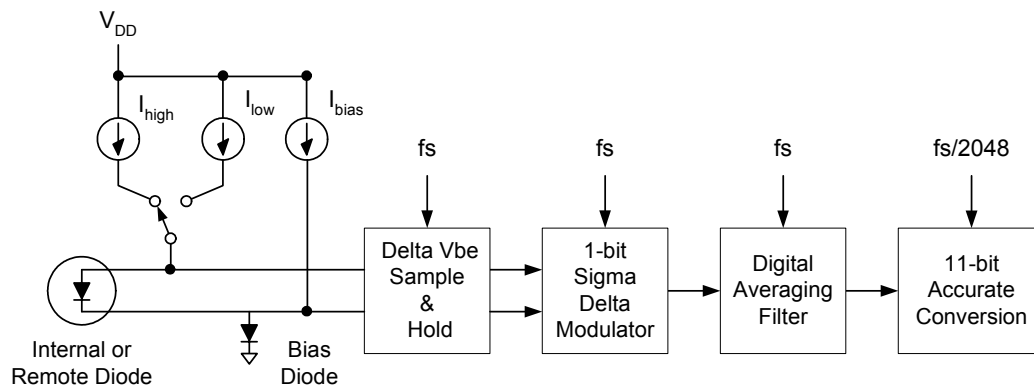

Figure 3.2 Detailed Block Diagram of Temperature Monitor Architecture

Figure 3.2 shows a detailed block diagram of the temperature measurement circuit. As shown, the EMC1201 and EMC1202 incorporates switched capacitor technology that samples the temperature diode voltage at two bias currents and holds the difference voltage. The sample frequency is 100kHz and the current levels I_{high} and I_{low} are 170uA and 10uA respectively.

The output of the switched capacitor sample and hold circuit interfaces to a single bit delta sigma analog to digital converter. This ADC runs at 100kHz sample frequency and its output is digitally filtered and averaged over 2048 samples effectively generating 11 bit accuracy.

The advantages of this architecture over Nyquist rate FLASH or SAR converters are superb linearity and inherent noise immunity. The linearity can be directly attributed to the delta sigma ADC single bit comparator while the noise immunity is achieved by the digital averaging filter. The overall effective bandwidth of the system is $f_s/2048$ which translates to a 50Hz bandwidth at 100kHz sample rate. Conversion time equals about 20ms per temperature monitor.

3.1.1 EMC1202 Temperature Monitoring

The EMC1202, incorporates one internal diode and can monitor an additional temperature zone via one external diode. An internal analog multiplexer switches between the internal and external diode. Total conversion time for one internal and one external temperature reading is about 40ms. The external diode can be either a CPU substrate diode or a discrete diode connected transistor like the 2N3904 or 2N3906. External diode connected transistors examples are shown in Figure 3.3:

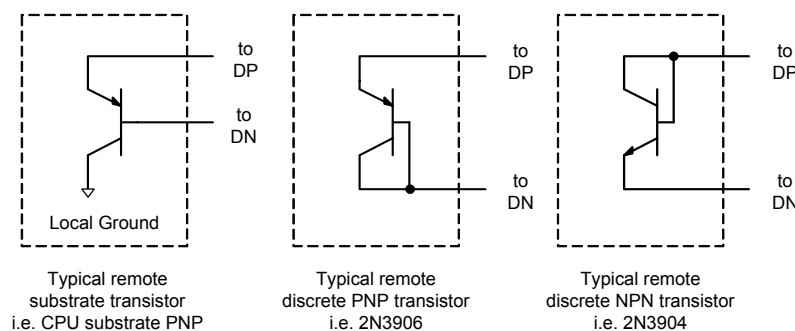

Figure 3.3 EMC1202 External Diode Examples

3.2 SMSC BudgetBus™ Sensor Interface

The EMC1201 and EMC1202 communicate with a host controller, such as the KBC1100, through the proprietary single wire SMSC BudgetBus™ Sensor Interface known as BBUS. The BBUS is a single

wire serial communication protocol between the computer host and its peripheral devices. Please refer to the BBUS Specification for detailed information about the modes of operation.

3.3 Power Modes

The EMC1201 and EMC1202 have two basic modes of operation:

Standby Mode:

The host can initiate standby mode by actively pulling the BBUS low. When the Host places the device in standby mode, the device immediately powers down to draw < 2uA of supply current. It will remain in this state until it is awakened by the host. If the host pulls the BBUS line low while temperature data is being clocked out, the device will not enter standby mode until completion of the data transfer. After entering standby mode, the device will remain in this mode until it is forced into active mode by the host. The transition from standby to active mode occurs when the host is no longer pulling the BBUS low.

Active Mode:

The host initiates active mode by enabling a weak pull up on the BBUS. In this mode, the EMC1201 and EMC1202 continuously convert temperature data. During the time that the device is actively converting a temperature, the BBUS is in tri-state mode, and the Host places a weak pull-up on the bus to prevent it from floating. After a conversion is completed, the device automatically clocks out the data from the most recent conversion to the host. When the data packet has been entirely clocked out, the BBUS returns to tri-state mode, and the ADC begins converting the next temperature sample. While BBUS is in tri-state mode, the host can command the device to standby mode.

3.4 Temperature Data Format

Temperature readings are coded in 2's complement format with a -64°C offset. This format spans from -63.875°C to +191.875°C with 0.125°C resolution. A temperature measurement outside this range is reported as either -63.875°C or +191.875°C. The host must add 64°C to calculate the actual temperature. [Table 3.1](#) shows example temperature readings and the value that will be reported on the BBUS.

Table 3.1 Temperature Data Format

ACTUAL TEMP. (°C)	2'S COMPLEMENT OF -64°C OFFSET	HEX
Diode Fault	100 0000 0000	400
-63.875	100 0000 0001	401
-63.000	100 0000 1000	408
-1.000	101 1111 1000	5F8
0.000	110 0000 0000	600
+0.125	110 0000 0001	601
+1.000	110 0000 1000	608

As shown in [Table 3.1](#), 400h is reserved for diode fault signaling which occurs when open or short conditions are detected between the external DP and DN pins.



Datasheet

3.5 Conversion Rate

The conversion rate can be controlled by the host. This is accomplished by periodically placing the device in standby as described in [Section 3.3, "Power Modes"](#).



Chapter 4 Package Outline

Revision 1.0 (06-14-06)

10
 DATASHEET

SMSC EMC1201/EMC1202

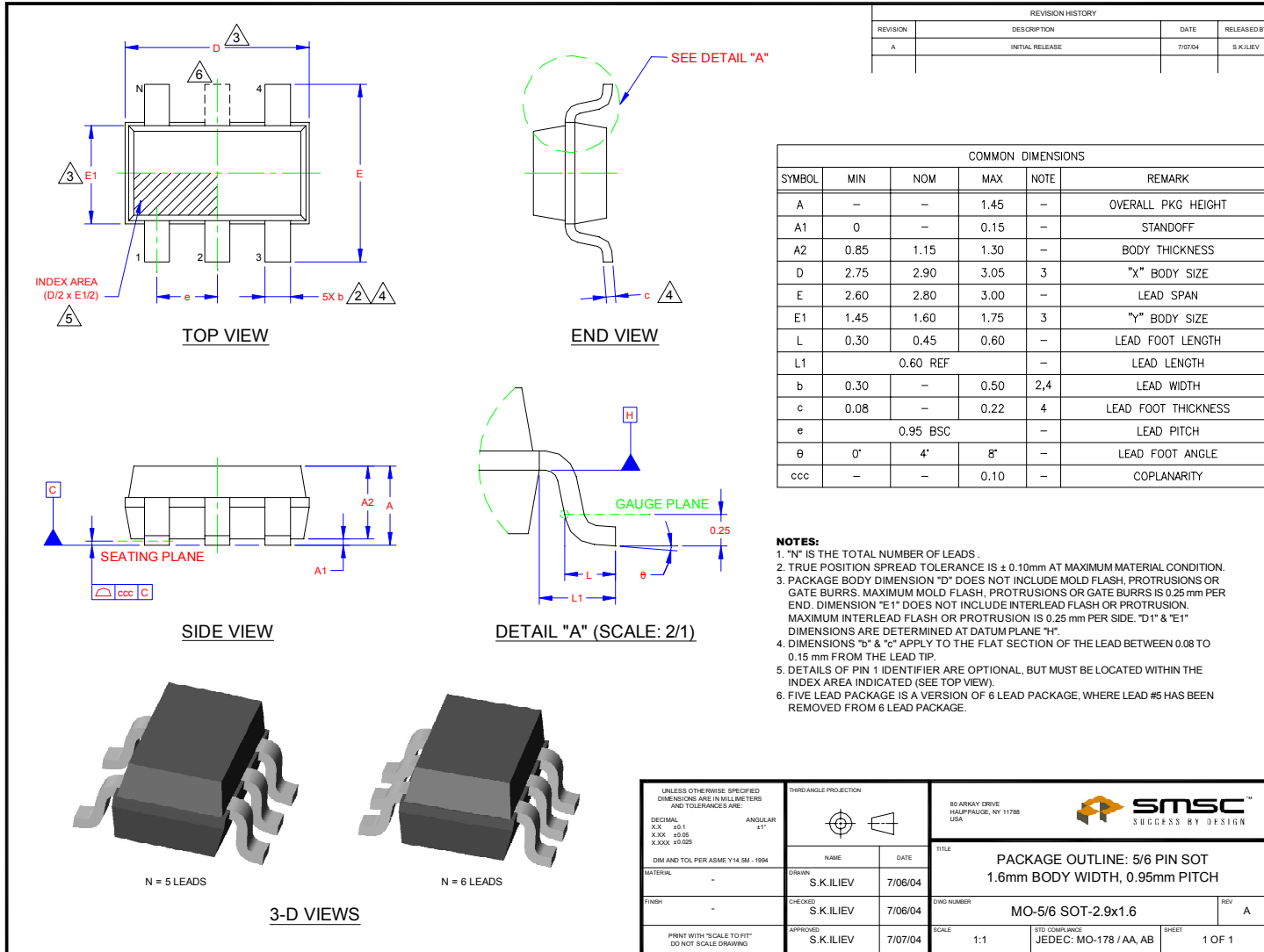

Figure 4.1 EMC1201/EMC1202 5 Pin SOT Package Outline; 1.6mm Body Width, 0.95mm Pitch