

## RPM-Based Fan Controller with HW Thermal Shutdown

### PRODUCT FEATURES

Datasheet

#### GENERAL DESCRIPTION

The EMC2102 is an SMBus, closed-loop, RPM-based fan controller/driver with hardware (HW) thermal shutdown and reset controller. The EMC2102 is packaged in a thermally enhanced, compact, 5x5, 28-pin lead-free RoHS compliant QFN package.

The EMC2102 utilizes Beta Compensation and Resistance Error Correction (REC) to accurately monitor three external temperature zones. These features allow great accuracy for CPU substrate thermal diodes on multiple process geometries as well as with discrete diode-connected transistors. Both Beta Compensation and REC can be disabled on the EMC2102 to maintain accuracy when monitoring AMD thermal diodes.

The EMC2102 includes a closed-loop RPM based Fan Control Algorithm that integrates a linear fan driver capable of sourcing 600mA of current. The fan control algorithm is designed to work with fans that operate up to 16,000 RPMs.

The EMC2102 provides a stand-alone HW thermal shutdown block. The HW thermal shutdown logic can be configured for a few common configurations based on the strapping level of the SHDN\_SEL pin on the PCB. The HW thermal shutdown point can be set in 1°C increments by using a discrete resistor divider implemented on the TRIP\_SET pin.

The EMC2102 also provides 5V supply 'power good' function with a threshold of 4.5V. This function is provided on the RESET# pin.

#### FEATURES

- Beta Compensation Allows Accurate Temperature Measurement on 65nm CPU/GPUs
- Closed-Loop RPM Based Fan Controller
  - Accepts External Clock Source To Achieve 2% Accuracy
- Integrated Linear Fan Driver
  - 600mA Drive Capability
- HW Thermal Shutdown (SYS\_SHDN#)
  - 1°C Incremental Set Points For Thermal Shutdown
  - Cannot be disabled by software
- Provides Reset Function (RESET#) On 5V Supply
- Three Remote Thermal Zones
  - ±1°C Accuracy (60°C to 100°C)
  - 1°C Resolution
- Resistance Error Correction On Thermal 'Diode' Channels
  - Eliminates Temperature Offset Due To Series Resistance From PCB Traces And Thermal 'Diode'
- Thermally Enhanced, 28-pin, 5x5 QFN Lead-free RoHS Compliant Package
- Operates From Single 3.0 - 3.6V Supply
  - 5V Supply For Linear Fan Driver
- Software Configurable ALERT# Signal For Diode Fault, Fan Stall Or System Warning

#### APPLICATIONS

- Notebook Computers
- Desktop Computers
- Embedded Applications

**ORDER NUMBER:****EMC2102-DZK FOR 28-PIN QFN LEAD-FREE ROHS COMPLIANT PACKAGE (ADDRESS - 011\_1101)**

80 ARKAY DRIVE, HAUPPAUGE, NY 11788 (631) 435-6000, FAX (631) 273-3123

Copyright © 2006 SMSC or its subsidiaries. All rights reserved.

Circuit diagrams and other information relating to SMSC products are included as a means of illustrating typical applications. Consequently, complete information sufficient for construction purposes is not necessarily given. Although the information has been checked and is believed to be accurate, no responsibility is assumed for inaccuracies. SMSC reserves the right to make changes to specifications and product descriptions at any time without notice. Contact your local SMSC sales office to obtain the latest specifications before placing your product order. The provision of this information does not convey to the purchaser of the described semiconductor devices any licenses under any patent rights or other intellectual property rights of SMSC or others. All sales are expressly conditional on your agreement to the terms and conditions of the most recently dated version of SMSC's standard Terms of Sale Agreement dated before the date of your order (the "Terms of Sale Agreement"). The product may contain design defects or errors known as anomalies which may cause the product's functions to deviate from published specifications. Anomaly sheets are available upon request. SMSC products are not designed, intended, authorized or warranted for use in any life support or other application where product failure could cause or contribute to personal injury or severe property damage. Any and all such uses without prior written approval of an Officer of SMSC and further testing and/or modification will be fully at the risk of the customer. Copies of this document or other SMSC literature, as well as the Terms of Sale Agreement, may be obtained by visiting SMSC's website at <http://www.smisc.com>. SMSC is a registered trademark of Standard Microsystems Corporation ("SMSC"). Product names and company names are the trademarks of their respective holders.

SMSC DISCLAIMS AND EXCLUDES ANY AND ALL WARRANTIES, INCLUDING WITHOUT LIMITATION ANY AND ALL IMPLIED WARRANTIES OF MERCHANTABILITY, FITNESS FOR A PARTICULAR PURPOSE, TITLE, AND AGAINST INFRINGEMENT AND THE LIKE, AND ANY AND ALL WARRANTIES ARISING FROM ANY COURSE OF DEALING OR USAGE OF TRADE. IN NO EVENT SHALL SMSC BE LIABLE FOR ANY DIRECT, INCIDENTAL, INDIRECT, SPECIAL, PUNITIVE, OR CONSEQUENTIAL DAMAGES; OR FOR LOST DATA, PROFITS, SAVINGS OR REVENUES OF ANY KIND; REGARDLESS OF THE FORM OF ACTION, WHETHER BASED ON CONTRACT; TORT; NEGLIGENCE OF SMSC OR OTHERS; STRICT LIABILITY; BREACH OF WARRANTY; OR OTHERWISE; WHETHER OR NOT ANY REMEDY OF BUYER IS HELD TO HAVE FAILED OF ITS ESSENTIAL PURPOSE, AND WHETHER OR NOT SMSC HAS BEEN ADVISED OF THE POSSIBILITY OF SUCH DAMAGES.

## Table of Contents

<b>Chapter 1</b>	<b>Block Diagram</b>	<b>7</b>
<b>Chapter 2</b>	<b>Pinout</b>	<b>8</b>
2.1	Pin Layout for EMC2102	8
2.2	Pin Description for EMC2102	9
<b>Chapter 3</b>	<b>Electrical Specifications</b>	<b>11</b>
3.1	Absolute Maximum Ratings	11
3.2	Electrical Specifications	11
3.3	SMBus Electrical Specifications	13
<b>Chapter 4</b>	<b>System Management Bus Interface Protocol</b>	<b>15</b>
4.1	Write Byte	15
4.2	Read Byte	16
4.3	Send Byte	16
4.4	Receive Byte	16
4.5	Alert Response Address	16
4.6	SMBus Address	17
4.7	SMBus Time-out	17
<b>Chapter 5</b>	<b>General Description</b>	<b>18</b>
5.1	Temperature Monitoring	20
5.1.1	Resistance Error Correction	20
5.1.2	Beta Compensation	20
5.1.3	Fault Queue	20
5.2	Fan Control Modes of Operation	21
5.3	RPM based Fan Control Algorithm	21
5.3.1	Programming the RPM based Fan Control Algorithm	23
5.3.2	TACH Measurement	23
	Stalled Fan 23	
5.3.3	Spin Up Routine	23
5.3.4	FAN_MODE Pin	25
5.3.5	32.768KHz Clock Source	25
5.4	Watchdog Timer	25
5.5	High Side Fan Driver	26
5.5.1	Overcurrent Limit	26
5.6	Internal Thermal Shutdown (TSD)	26
5.7	Critical/Thermal Shutdown	26
5.7.1	TRIP_SET	28
5.7.2	SHDN_SEL Pin	28
5.7.3	Internal HW_SHDN Signal	29
5.8	5V Reset Controller	30
<b>Chapter 6</b>	<b>Register Set</b>	<b>31</b>
6.1	Register Map	31
6.1.1	Lock Entries	32
6.2	Temperature Data Registers	33
6.3	Critical/Thermal Shutdown Temperature Register	34
6.4	Configuration Register	34
6.5	Conversion Rate Register	35
6.6	Interrupt Status Register 1	36

6.7	Interrupt Status Register 2 .....	37
6.8	Interrupt Mask Register .....	37
6.9	Beta Configuration Registers .....	38
6.10	REC Configuration Register .....	39
6.11	Temperature Limit Registers .....	40
6.12	Fan Driver Setting Register .....	40
6.13	Fan Configuration Register .....	41
6.14	Fan Spin Up Configuration Register .....	42
6.15	Fan Step Register .....	43
6.16	Fan Minimum Drive Register .....	43
6.17	Valid TACH Count Register .....	44
6.18	TACH Target Register .....	44
6.19	TACH Reading Register .....	44
6.20	Product ID Register .....	45
6.21	Revision Register .....	45
<hr/>		
<b>Chapter 7</b>	<b>Package Drawing .....</b>	<b>46</b>
<hr/>		
<b>Appendix A</b>	<b>TACH Reading Table - 2000 RPM Range .....</b>	<b>47</b>
<hr/>		
<b>Appendix B</b>	<b>TACH Reading Table - 500RPM Range .....</b>	<b>50</b>

## List of Tables

Table 2.1	Pin Description	9
Table 3.1	Absolute Maximum Ratings	11
Table 3.2	Electrical Specifications	11
Table 3.3	SMBus Electrical Specifications	13
Table 4.1	Protocol Format	15
Table 4.2	Write Byte Protocol	15
Table 4.3	Read Byte Protocol	16
Table 4.4	Send Byte Protocol	16
Table 4.5	Receive Byte Protocol	16
Table 4.6	Alert Response Address Protocol	16
Table 5.1	Fan Controls Active for Operating Mode	21
Table 5.2	FAN_MODE Pin Functions	25
Table 5.3	CLK_SEL Pin Functions	25
Table 5.4	SHDN_SEL Pin Configuration	28
Table 6.1	EMC2102 Register Set	31
Table 6.2	Temperature data Registers	33
Table 6.3	Temperature Data Format	33
Table 6.4	Critical/Thermal Shutdown Temperature Register	34
Table 6.5	Configuration Register	34
Table 6.6	Fault Queue	34
Table 6.7	Conversion Rate Register	35
Table 6.8	Conversion Rate	36
Table 6.9	Interrupt Status Register 1	36
Table 6.10	Interrupt Status Register 2	37
Table 6.11	Interrupt Mask Register	37
Table 6.12	Beta Configuration Registers	38
Table 6.13	Beta Compensation Look Up Table	39
Table 6.14	REC Configuration Register	39
Table 6.15	Temperature Limit Registers	40
Table 6.16	Fan Driver Setting Register	40
Table 6.17	Fan Control Configuration Register	41
Table 6.18	Minimum Edges for Fan Rotation	41
Table 6.19	Update Time	42
Table 6.20	Fan TACH Configuration Register	42
Table 6.21	Spin Time	42
Table 6.22	Fan Step Register	43
Table 6.23	Minimum Fan Drive Register	43
Table 6.24	Valid TACH Count Register	44
Table 6.25	TACH Reading Registers	44
Table 6.26	TACH Reading Register	44
Table 6.27	Example TACH Reading for Specific Fan Speeds	45
Table 6.28	Product ID Register	45
Table 6.29	Revision Register	45

## List of Figures

Figure 1.1	EMC2102 Block Diagram	7
Figure 2.1	EMC2102 Pin Diagram	8
Figure 4.1	SMBus Timing Diagram	15
Figure 5.1	EMC2102 System Diagram	19
Figure 5.2	RPM based Fan Control Algorithm	22
Figure 5.3	Spin Up Routine	24
Figure 5.4	EMC2102 Critical/Thermal Shutdown Block Diagram	27
Figure 5.5	HW_SHDN Operation	29
Figure 5.6	5V Reset Controller Timing	30
Figure 7.1	EMC2102 28-Pin 5x5mm QFN Package Outline and Parameters	46

# Chapter 1 Block Diagram

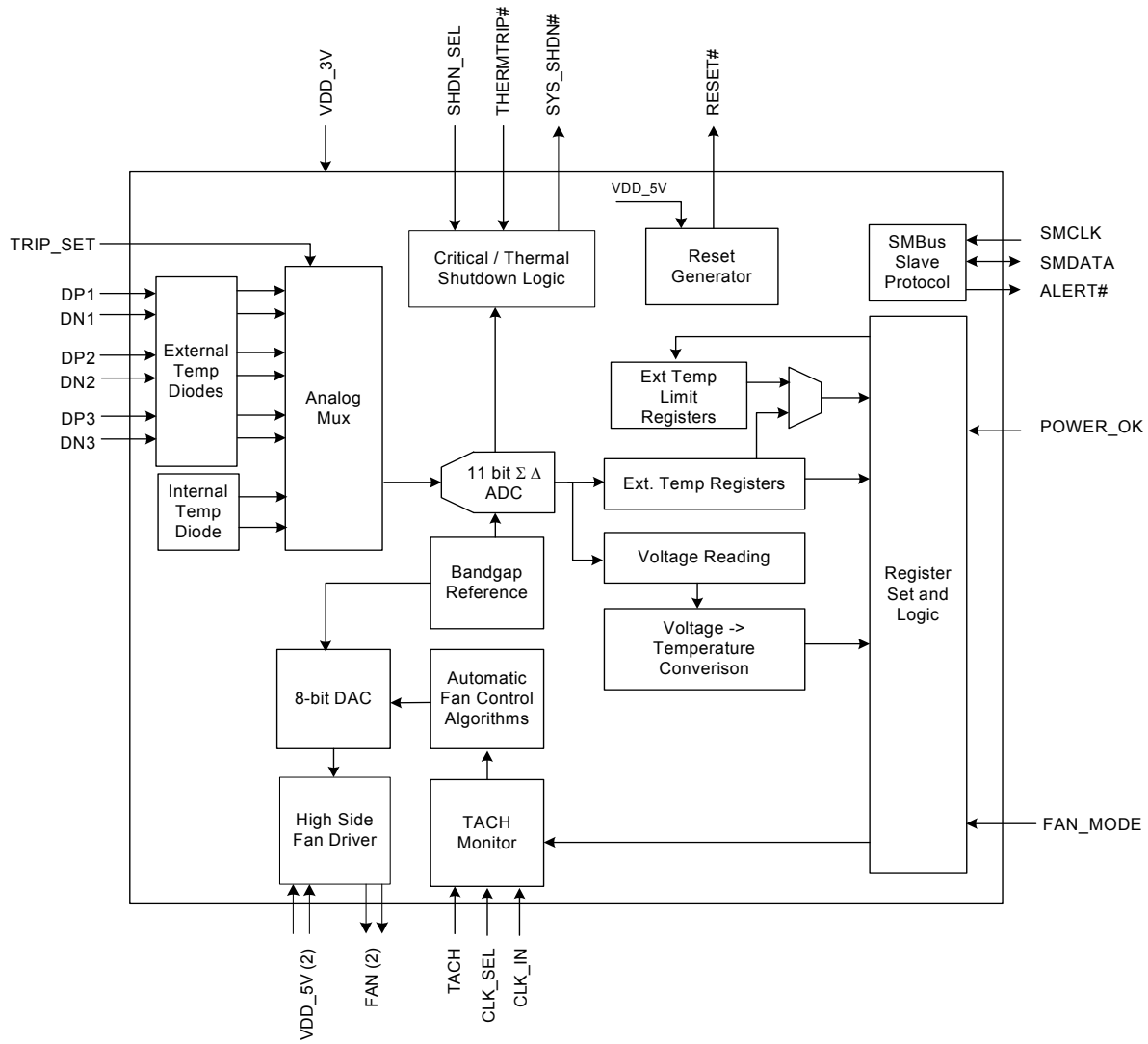

Figure 1.1 EMC2102 Block Diagram

## Chapter 2 Pinout

### 2.1 Pin Layout for EMC2102

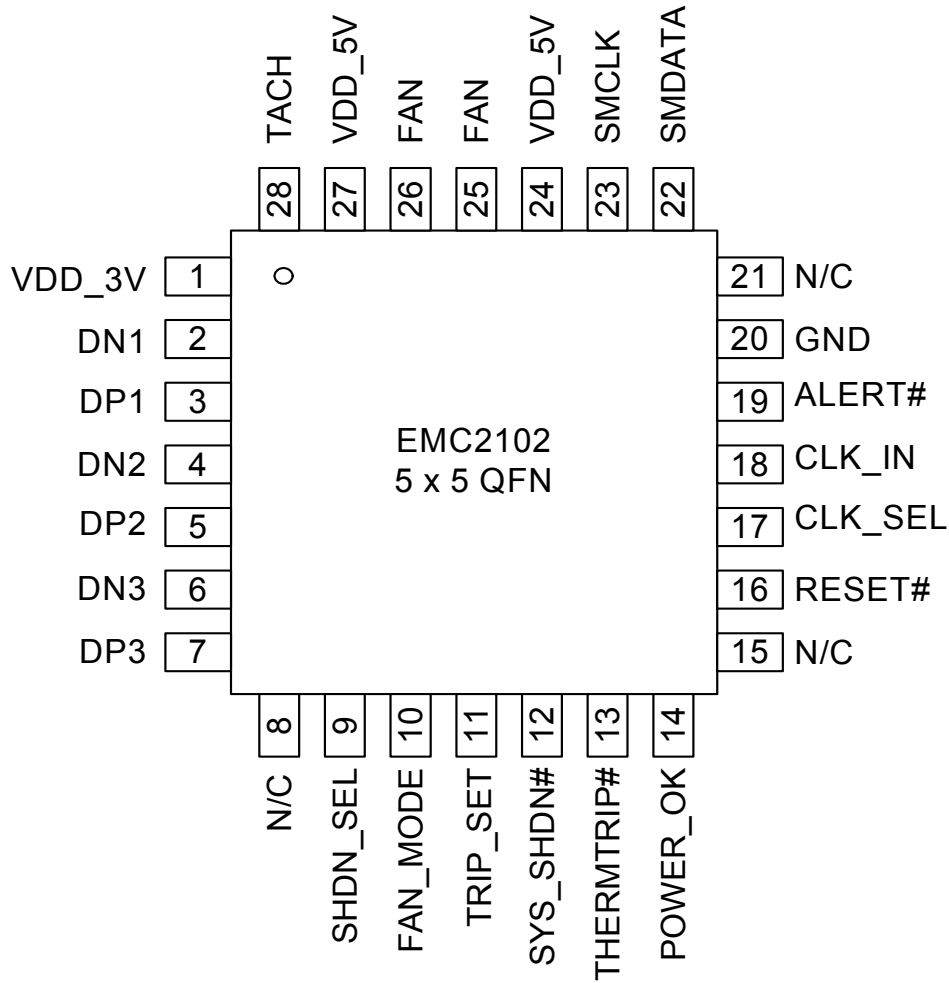

Figure 2.1 EMC2102 Pin Diagram



## Datasheet

## 2.2 Pin Description for EMC2102

Table 2.1 Pin Description

PIN	NAME	FUNCTION	TYPE
1	VDD_3V	Supply Connection of 3.3V.	Power
2	DN1	Negative (cathode) Analog Input for External Diode 1.	AIO
3	DP1	Positive (anode) Analog Input for External Diode 1.	AIO
4	DN2	Negative (cathode) Analog Input for External Diode 2.	AIO
5	DP2	Positive (anode) Analog Input for External Diode 2.	AIO
6	DN3	Negative (cathode) Analog Input for External Diode 3.	AIO
7	DP3	Positive (anode) Analog Input for External Diode 3.	AIO
8	N/C	Not internally connected.	N/A
9	SHDN_SEL	Determines HW Shutdown temperature channel (see <a href="#">Table 5.4.</a> )	DIT
10	FAN_MODE	Selects power-up default for fan drive setting.	DIT
11	TRIP_SET	Voltage input to determine HW Shutdown threshold temperature	AI
12	SYS_SHDN#	Active low Critical System Shutdown output	OD (5V)
13	THERMTRIP#	Active low Critical temperature limit signal from the CPU or chipset.	IP
14	POWER_OK	Active high power good input.	DI (5V)
15	N/C	Not internally connected.	N/A
16	RESET#	Active low reset output.	DO
17	CLK_SEL	Selects internal oscillator or external clock.	DI (5V)
18	CLK_IN	32.768KHz clock input.	DI (5V)
19	ALERT#	Active low interrupt.	OD (5V)
20	GND	GND connection.	Power
21	N/C	Not internally connected.	N/A
22	SMDATA	SMBus data input/output.	DIOD (5V) - requires external upll-up resistor
23	SMCLK	SMBus clock input.	DI (5V) - requires external pull-up resistor

**Table 2.1 Pin Description (continued)**

PIN	NAME	FUNCTION	TYPE
24	VDD_5V	5V supply input for the linear fan driver. Both VDD_5V pins should be connected to same 5V supply.	Power
25	FAN	Linear fan drive signal. Both FAN pins should be connected together.	AO
26	FAN	Linear fan drive signal. Both FAN pins should be connected together.	AO
27	VDD_5V	5V supply input for the linear fan driver. Both VDD_5V pins should be connected to same 5V supply.	Power
28	TACH	Input from the tachometer pin of the fan.	DI (5V)

The pin type are described in detail below. All pins labelled with (5V) are 5V tolerant.:

Power - this pin is used to supply power to the device.

DI - Digital Input - this pin is used as a digital input. This pin is 5V tolerant.

AI - Analog Input - this pin is used as an input for analog signals..

AO - Analog Output - this pin is used as an output for analog signals.

AIO - Analog Input / Output - this pin is used as an I/O for analog signals.

DO - Push / Pull Digital Output - this pin is used as a digital output. It can both source and sink current and doesn't require a pull-up resistor.

DIOD - Open Drain Digital Input / Output - this pin is used as an digital I/O. It is open drain and requires a pull-up resistor. This pin is 5V tolerant.

OD - Open Drain Digital Output - this pin is used as a digital output. It is open drain and requires a pull-up resistor.

DIT - Tri-stated Digital Input - this pin is a digital input that supports 3 logic levels at the input: logic high, logic low, or high impedance (open).

IP - Digital Input - this pin has an internal 30uA pull-up current to VDD\_3V

## Chapter 3 Electrical Specifications

### 3.1 Absolute Maximum Ratings

**Table 3.1 Absolute Maximum Ratings**

Voltage on VDD_5V Pins and 5V tolerant pins (see Table 2.1)	-0.3 to 6.5	V
Voltage on VDD_3V pin	-0.3 to 4	V
Voltage on FAN pins	-0.3 to VDD_5V + 0.3	V
Voltage on any other pin to GND	-0.3 to VDD_3V + 0.3	V
Package Power Dissipation	0.9 up to $T_A = 85^\circ\text{C}$ Note 3.2	W
Junction to Ambient ( $\theta_{JA}$ ) Note 3.3	37	$^\circ\text{C/W}$
Operating Ambient Temperature Range	0 to 85	$^\circ\text{C}$
Operating Die Temperature Range	0 to 125	$^\circ\text{C}$
Storage Temperature Range	-55 to 150	$^\circ\text{C}$
ESD Rating, All Pins, HBM	2000	V

These ratings are absolute maximum values. Exceeding these values or operating at these values for an extended period of time may cause permanent damage to the device.

**Note 3.1** All voltages are relative to ground.

**Note 3.2** The Package Power Dissipation specification assumes a thermal via design consisting of four 20mil vias connected to the ground plane with a 3.1mm x 3.1mm thermal landing.

**Note 3.3** Junction to Ambient ( $\theta_{JA}$ ) is dependent on the design of the thermal vias. Without thermal vias and a thermal landing, the  $\theta_{JA}$  is approximately  $60^\circ\text{C/W}$  including localized PCB temperature increase.

### 3.2 Electrical Specifications

**Table 3.2 Electrical Specifications**

$V_{DD\_3V} = 3\text{V to } 3.6\text{V}$ , $V_{DD\_5V} = 4.6\text{V} - 5.5\text{V}$ , $T_A = 0^\circ\text{C to } 85^\circ\text{C}$ all Typical values at $T_A = 27^\circ\text{C}$ unless otherwise noted.						
CHARACTERISTIC	SYMBOL	MIN	TYP	MAX	UNIT	CONDITIONS
DC Power						
3.3V Supply Voltage	$V_{DD\_3V}$	3	3.3	3.6	V	
5V Supply Voltage	$V_{DD\_5V}$	4.6	5	5.5	V	
Supply Current from VDD_3V pin	$I_{DD3}$		500	750	$\mu\text{A}$	Fan Driver enabled
Supply Current from VDD_5V pin	$I_{DD5}$		200		$\mu\text{A}$	Fan Driver enabled

**Table 3.2 Electrical Specifications (continued)**

VDD_3V = 3V to 3.6V, VDD_5V = 4.6V - 5.5V, T <sub>A</sub> = 0°C to 85°C all Typical values at T <sub>A</sub> = 27°C unless otherwise noted.						
CHARACTERISTIC	SYMBOL	MIN	TYP	MAX	UNIT	CONDITIONS
External Temperature Monitors						
Temperature Accuracy			±1	±1.5	°C	60°C < T <sub>DIODE</sub> < 100°C 30°C < T <sub>DIE</sub> < 85°C (Note 3.4)
			±1	±3	°C	0°C < T <sub>DIODE</sub> < 125°C, 0°C < T <sub>DIE</sub> < 115°C (Note 3.4)
Temperature Resolution			1		°C	
Diode decoupling capacitor	C <sub>FILTER</sub>			2200	pF	Connected across external 2N3904 diode or AMD diode (Note 3.5)
				470	pF	Connected across CPU or GPU thermal diode (Note 3.5)
Resistance Error Corrected	R <sub>SERIES</sub>			100	Ohm	Series resistance in DP and DN lines
Internal Temperature Monitor						
Temperature Accuracy			±3		°C	(Note 3.4)
Temperature Resolution			1		°C	
Reset Generator						
Reset Voltage	V <sub>RESET</sub>	4.3	4.4	4.5	V	V <sub>DD_5V</sub> rising edge 3V < V <sub>DD_3V</sub> < 3.6V
Hysteresis	ΔV <sub>RESET</sub>		100		mV	
Time Delay	t <sub>RESET</sub>		220		ms	
High Side Fan Driver						
Output High Voltage from 5V supply	V <sub>OH_5V</sub>			VDD_5V - 0.4	V	I <sub>SOURCE</sub> = 600mA, VDD_5V = 5V
Fan Drive Current	I <sub>SOURCE</sub>			600	mA	
Overcurrent Limit	I <sub>OVER</sub>		1500		mA	Momentary Current drive at startup for < 2 seconds
DC Short Circuit Current Limit	I <sub>SHORT</sub>		800		mA	Sourcing current, Thermal shutdown not triggered, FAN_OUT = 0V
Short circuit delay	t <sub>DFS</sub>		2		s	
Output Capacitive Load	C <sub>LOAD</sub>			100	uF	
ESR on C <sub>LOAD</sub>	R <sub>ESR</sub>	0		2	Ohm	

**Table 3.2 Electrical Specifications (continued)**

VDD_3V = 3V to 3.6V, VDD_5V = 4.6V - 5.5V, T <sub>A</sub> = 0°C to 85°C all Typical values at T <sub>A</sub> = 27°C unless otherwise noted.						
CHARACTERISTIC	SYMBOL	MIN	TYP	MAX	UNIT	CONDITIONS
RPM Based Fan Controller						
TACH Range	TACH	480		16000	RPM	
TACH Setting Accuracy	$\Delta_{TACH}$		±1	±2	%	External oscillator 32.768kHz
	$\Delta_{TACH}$		±5	±7.5	%	Internal Oscillator 40°C < T <sub>DIE</sub> < 100°C
Thermal Shutdown						
Thermal Shutdown Threshold	TSD <sub>TH</sub>		150		°C	
Thermal Shutdown Hysteresis	TSD <sub>HYST</sub>		50		°C	
SMBus and Digital I/O pins						
Output High Voltage	V <sub>OH</sub>	VDD_3V 0.4			V	2 mA current drive
Output Low Voltage	V <sub>OL</sub>			0.5	V	4mA current sink

**Note 3.4** T<sub>DIE</sub> refers to the internal die temperature and may not match T<sub>A</sub> due to self heating of the device. The internal temperature sensor will return T<sub>DIE</sub>.

**Note 3.5** Contact SMSC for Application Notes and guidelines when measuring GPU processor diodes and CPU processor diodes.

### 3.3 SMBus Electrical Specifications

**Table 3.3 SMBus Electrical Specifications**

VDD_3V = 3V to 3.6V, VDD_5V = 4.6 to 5.5V, T <sub>A</sub> = 0°C to 85°C Typical values are at T <sub>A</sub> = 27°C unless otherwise noted.						
CHARACTERISTIC	SYMBOL	MIN	TYP	MAX	UNITS	CONDITIONS
SMBus Interface						
Input High Voltage	V <sub>IH</sub>	2.0			V	
Input Low Voltage	V <sub>IL</sub>			0.8	V	
Input High/Low Current	I <sub>IH</sub> / I <sub>IL</sub>	-1		1	uA	
Input Capacitance	C <sub>IN</sub>		5		pF	
Output Low Sink Current			4		mA	SMDATA = 0.5V
SMBus Timing						
Clock Frequency	f <sub>SMB</sub>	10		400	kHz	
Spike Suppression	t <sub>SP</sub>			50	ns	

**Table 3.3 SMBus Electrical Specifications (continued)**

VDD_3V = 3V to 3.6V, VDD_5V = 4.6 to 5.5V, T <sub>A</sub> = 0°C to 85°C Typical values are at T <sub>A</sub> = 27°C unless otherwise noted.						
CHARACTERISTIC	SYMBOL	MIN	TYP	MAX	UNITS	CONDITIONS
Bus free time Start to Stop	t <sub>BUF</sub>	1.3			us	
Setup Time: Start	t <sub>SU:STA</sub>	0.6			us	
Setup Time: Stop	t <sub>SU:STP</sub>	0.6			us	
Data Hold Time	t <sub>HD:DAT</sub>	0.6		6	us	
Data Setup Time	t <sub>SU:DAT</sub>	0.6		72	us	
Clock Low Period	t <sub>LOW</sub>	1.3			us	
Clock High Period	t <sub>HIGH</sub>	0.6			us	
Clock/Data Fall time	t <sub>FALL</sub>			300	ns	Min = 20+0.1C <sub>LOAD</sub> ns
Clock/Data Rise time	t <sub>RISE</sub>			300	ns	Min = 20+0.1C <sub>LOAD</sub> ns
Capacitive Load	C <sub>LOAD</sub>			400	pF	per bus line

## Chapter 4 System Management Bus Interface Protocol

The EMC2102 communicates with a host controller, such as an SMSC SIO, through the SMBus. The SMBus is a two-wire serial communication protocol between a computer host and its peripheral devices. A detailed timing diagram is shown in [Figure 4.1](#). Stretching of the SMCLK signal is supported, however the EMC2102 will not stretch the clock signal.

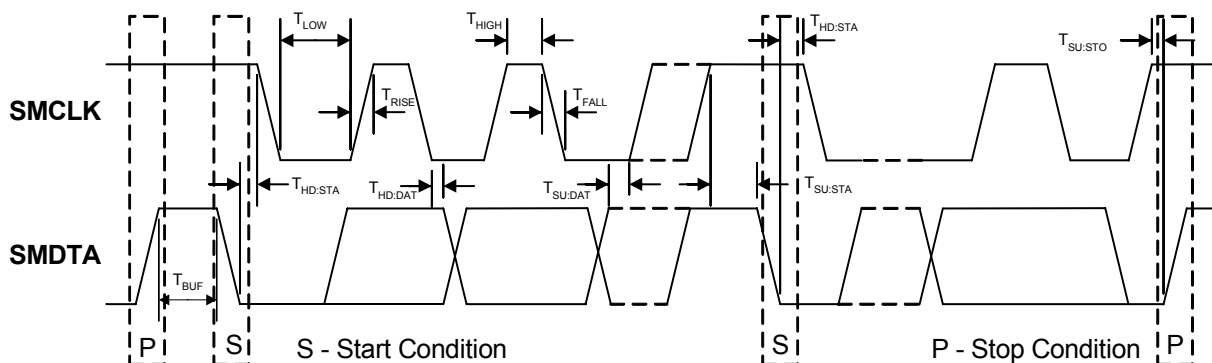

**Figure 4.1 SMBus Timing Diagram**

The EMC2102 is SMBus 2.0 compatible and supports Send Byte, Read Byte, Receive Byte and Write Byte as valid protocols as shown below. It will respond to the Alert Response Address protocol but is not in full compliance.

All of the below protocols use the convention in [Table 4.1](#).

**Table 4.1 Protocol Format**

DATA SENT TO DEVICE	DATA SENT TO THE HOST
# of bits sent	# of bits sent

### 4.1 Write Byte

The Write Byte is used to write one byte of data to the registers as shown below [Table 4.2](#):

**Table 4.2 Write Byte Protocol**

START	SLAVE ADDRESS	WR	ACK	REGISTER ADDRESS	ACK	REGISTER DATA	ACK	STOP
1	7	1	1	8	1	8	1	1

## 4.2 Read Byte

The Read Byte protocol is used to read one byte of data from the registers as shown in [Table 4.3](#).

**Table 4.3 Read Byte Protocol**

START	SLAVE ADDRESS	W R	ACK	Register Address	ACK	START	Slave Address	RD	ACK	Register Data	NACK	STOP
1	7	1	1	8	1	1	7	1	1	8	1	1

## 4.3 Send Byte

The Send Byte protocol is used to set the internal address register pointer to the correct address location. No data is transferred during the Send Byte protocol as shown in [Table 4.4](#).

**Table 4.4 Send Byte Protocol**

START	SLAVE ADDRESS	WR	ACK	REGISTER ADDRESS	ACK	STOP
1	7	1	1	8	1	1

## 4.4 Receive Byte

The Receive Byte protocol is used to read data from a register when the internal register address pointer is known to be at the right location (e.g. set via Send Byte). This is used for consecutive reads of the same register as shown in [Table 4.5](#).

**Table 4.5 Receive Byte Protocol**

START	SLAVE ADDRESS	RD	ACK	REGISTER DATA	NACK	STOP
1	7	1	1	8	1	1

## 4.5 Alert Response Address

The ALERT# output can be used as a processor interrupt or as an  $\overline{\text{SMBALERT}}$ .

When it detects that the  $\overline{\text{SMBALERT}}$  pin is asserted, the host will send the Alert Response Address (general address of 000\_1100b) on the bus. All devices with active interrupts will respond with their client address as shown in [Table 4.6](#).

**Table 4.6 Alert Response Address Protocol**

START	ALERT RESPONSE ADDRESS	RD	ACK	DEVICE ADDRESS	NACK	STOP
1	7	1	1	8	1	1





**Datasheet**

The EMC2102 will respond to the ARA command if the ALERT# pin has been asserted but will not immediately release the ALERT# pin. The ALERT# pin is released under the following conditions.

1. The Interrupt Status Registers are read and the error condition has been removed.
2. The specific error condition is masked from asserting the ALERT# pin.

## **4.6 SMBus Address**

The EMC2102-1 is addressed on the SMBus as 011\_1101b.

Attempting to communicate with the EMC2102 SMBus interface with an invalid slave address or invalid protocol will result in no response from the device and will not affect its register contents.

## **4.7 SMBus Time-out**

The EMC2102 includes an SMBus time-out feature. Following a 30ms period of inactivity on the SMBus, the device will time-out and reset the SMBus interface.

## Chapter 5 General Description

The EMC2102 monitors three external temperature channels. Two of the external temperature channels can employ both Beta Compensation and Resistance Error Correction for use with thermal diodes while the third channel is hardwired to measure a discrete diode connected NPN or PNP transistor. The temperature data is available over a standard 2-wire serial interface using SMBus read commands. The temperature monitoring is described in more detail in [Section 5.1, "Temperature Monitoring"](#).

The EMC2102 integrates a closed-loop RPM based Fan Control Algorithm. A host writes the desired fan speed into a register of the EMC2102 via the SMBus and the integrated fan controller will maintain the fan at the desired speed using fan speed feedback from the TACH output from a 3-wire fan. The fan control algorithm controls an integrated 5V, 600mA, linear fan driver. The fan control algorithm functionality is described in more detail in [Section 5.3, "RPM based Fan Control Algorithm"](#)

The EMC2102 provides the system with a hardware based critical/thermal shutdown function. This critical/thermal shutdown function integrates critical signals from both the CPU and power supply and the analog circuitry to monitor a specific temperature channel based on the system configuration. The critical/thermal shutdown temperature threshold is configured on the PCB through a simple discrete resistor divider. The Critical/Thermal Shutdown function is described in more detail in [Section 5.7, "Critical/Thermal Shutdown"](#).

An example of a typical system configuration for the EMC2102 is provided in [Figure 5.1](#).

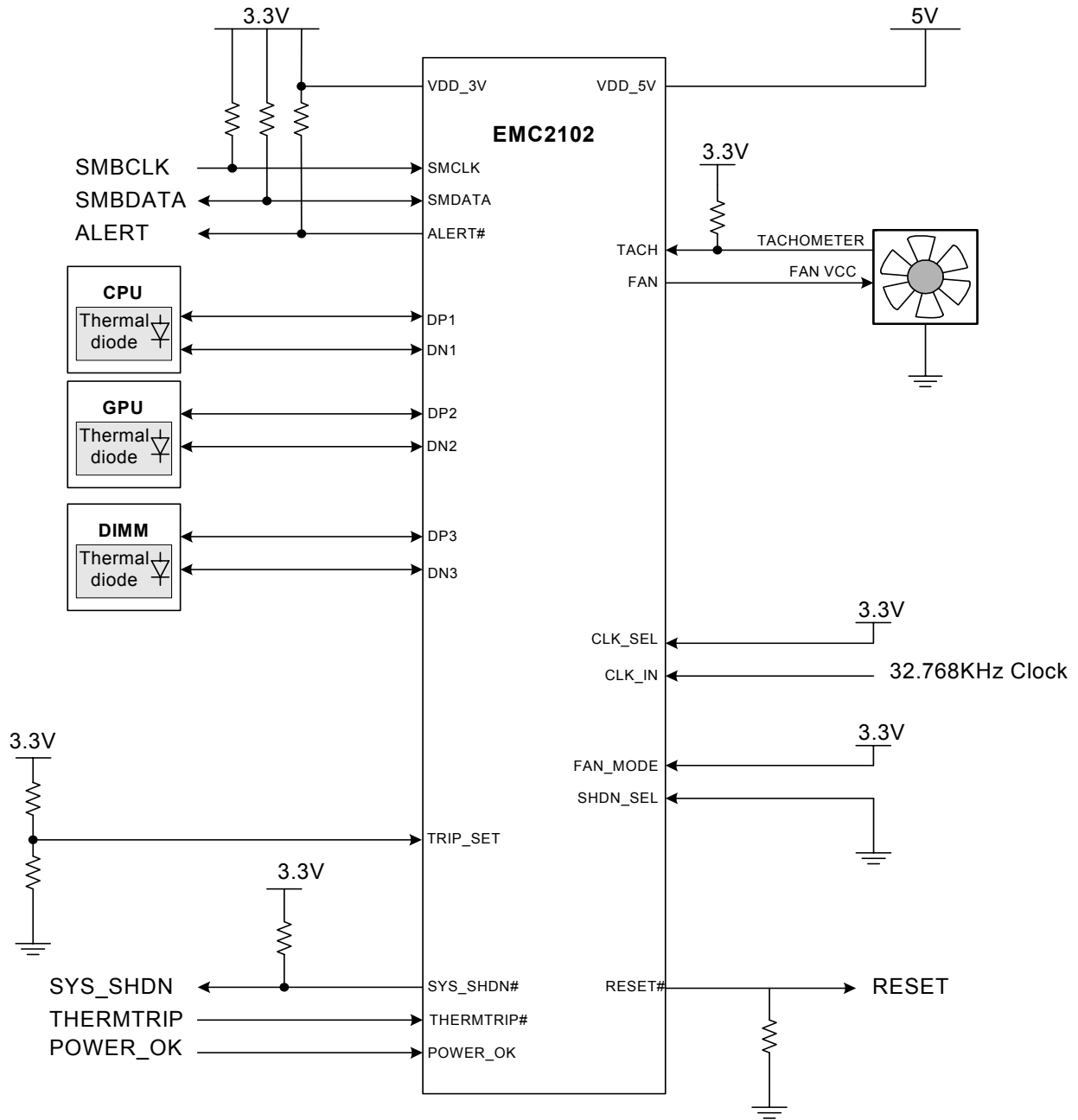

Figure 5.1 EMC2102 System Diagram

## 5.1 Temperature Monitoring

External diode channels one and two can be configured to monitor either discrete thermal diodes or a CPU / GPU thermal diode. External diode channel three is always configured to monitor a discrete diode-connected transistor (such as a 2N3904) or an AMD thermal diode. Each channel can enable the Resistance Error Correction functionality and external diode channels one and two can adjust the Beta Compensation settings (disabling it if desired). The disabling of these features is only recommended in two situations:

1. An AMD thermal diode is being monitored. The AMD thermal diode is physically a 2-terminal diode and will not function with either Beta Compensation or Resistance Error Correction. Because of this, when an EMC2102 temperature channel is interfacing an AMD thermal diode, both Beta Compensation and Resistance Error Correction must be disabled.
2. A discrete diode connected transistor (such as 2N3904) is used. In this configuration, Beta Compensation must be disabled, but Resistance Error Correction should remain enabled.

### 5.1.1 Resistance Error Correction

The EMC2102 includes active Resistance Error Correction to remove the effect of up to 100 ohms of series resistance. Without this automatic feature, voltage developed across the parasitic resistance in the remote diode path causes the temperature to read higher than the true temperature is. The error induced by parasitic resistance is approximately +0.7°C per ohm. Sources of parasitic resistance include bulk resistance in the remote temperature transistor junctions, series resistance in the CPU, and resistance in the printed circuit board traces and package leads. Resistance error correction in the EMC2102 eliminates the need to characterize and compensate for parasitic resistance in the remote diode path.

### 5.1.2 Beta Compensation

The forward current gain, or beta, of a transistor is not constant as emitter currents change. As well, it is not constant over changes in temperature. The variation in beta causes an error in temperature reading that is proportional to absolute temperature.

For discrete transistors configured with the collector and base shorted together, the beta is generally sufficiently high such that the percent change in beta variation is very small. For example, a 10% variation in beta for two forced emitter currents with a transistor whose ideal beta is 50 would contribute approximately 0.25°C error at 100°C. However for substrate transistors where the base-emitter junction is used for temperature measurement and the collector is tied to the substrate, the proportional beta variation will cause large error. For example, a 10% variation in beta for two forced emitter currents with a transistor whose ideal beta is 0.5 would contribute approximately 8.25°C error at 100°C.

The Beta Compensation circuitry in the EMC2102 corrects for this beta variation to eliminate any error which would normally be induced.

### 5.1.3 Fault Queue

To avoid spurious interrupts and Critical/Thermal Trip events induced by thermal spikes and noise injection, the selected Thermal / Critical Shutdown Temperature channel (see [Section 5.7.2](#)) is filtered through a fault queue. This fault queue requires that a user-defined number of consecutive out-of-limit errors be recorded before it will cause an interrupt or trigger the Critical/Thermal trip event.

The fault queue only applies to the measurement channels that will cause the SYS\_SHDN# pin to be asserted including any software configured channels (see [Section 5.7](#)). In addition, the fault queue applies to all enabled channels simultaneously and will trigger the SYS\_SHDN# pin if there are the desired number of consecutive measurements with any or all channels exceeding their corresponding limits.

## 5.2 Fan Control Modes of Operation

The EMC2102 has two modes of operation for the High Side Fan Driver. They are:

1. Manual Mode - in this mode of operation, the user directly controls the fan drive setting. Updating the Fan Driver Setting Register (see [Section 6.12](#)) will instantly update the fan drive.
  - The Manual Mode is enabled by clearing the EN bit in the Fan Configuration Register (see [Section 6.13](#)).
  - Whenever the Manual Mode is enabled the current drive will be changed to what was last written into the Fan Driver Setting Register.
  - Setting the drive value to 00h will disable the High Side Fan Driver for lower power operation.
2. Using RPM based Fan Control Algorithm - in this mode of operation, the user determines a target TACH count and the drive setting is automatically updated to achieve this target speed. The algorithm uses the Spin Up Routine and has user definable ramp rate controls.

**Table 5.1 Fan Controls Active for Operating Mode**

MANUAL MODE	ALGORITHM
Fan Driver Setting (read / write)	Fan Driver Setting (read only)
EDGES[1:0]	EDGES[1:0] (Fan Configuration)
-	UPDATE[2:0] (Fan Configuration)
-	LEVEL (Spin Up Configuration)
-	SPINUP_TIME[1:0] (Spin Up Configuration)
-	Fan Step
-	Fan Minimum Drive
Valid TACH Count	Valid TACH Count
-	TACH Target
TACH Reading	TACH Reading

## 5.3 RPM based Fan Control Algorithm

The EMC2102 includes a RPM based Fan Control Algorithm that controls an integrated linear High Side Fan Driver. This fan control algorithm automatically approaches and maintains the system's desired fan speed to an accuracy directly proportional to the accuracy of the clock source. [Figure 5.2](#) shows a simple flow diagram of the RPM based Fan Control Algorithm operation.

The desired TACH count is set by the user inputting the desired number of 32.768KHz cycles that occur per fan revolution. The user may change the target count at any time. The user may also set the target count to FFh in order to disable the fan driver for lower current operation.

For example, if a desired RPM rate for a 2-pole fan is 3000RPMs, then the user would input the hexadecimal equivalent of 655 (29h in the TACH Target Register). This number represents the number of 32.768KHz cycles that would occur during the time it takes the fan to complete a single revolution when it is spinning at 3000RPMs (see [Equation \[3\]](#) in [Section 6.19](#)).

The EMC2102's RPM based Fan Control Algorithm has programmable configuration settings for parameters such as ramp-rate control and spin up conditions. The fan driver automatically detects and attempts to alleviate a stalled/stuck fan condition while also asserting the ALERT# pin. The EMC2102 works with fans that operate up to 16,000 RPMs and provide a valid tachometer signal. The fan controller will function either with an externally supplied 32.768KHz clock source or with its own internal 32.768KHz oscillator depending on the required accuracy.

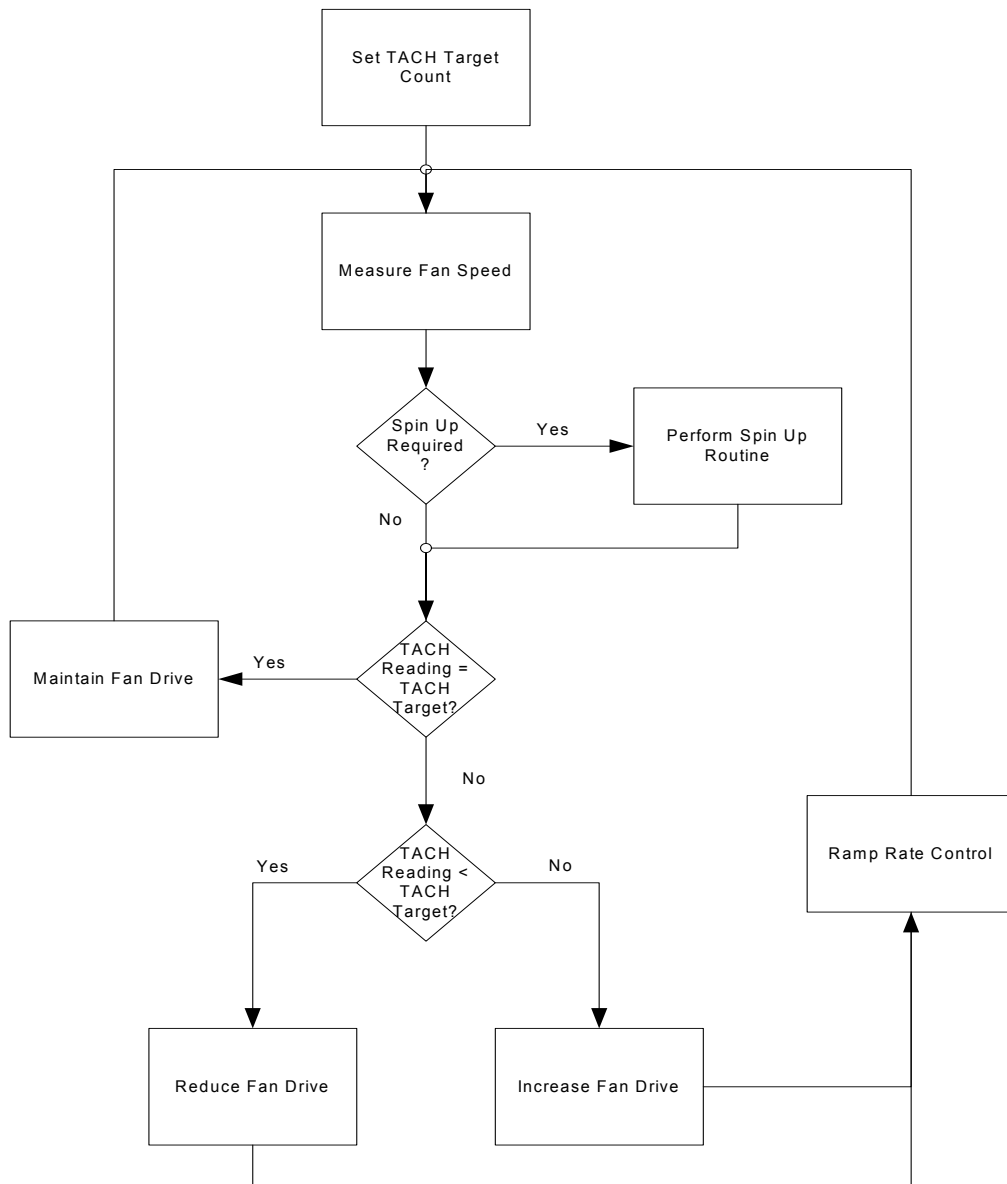

**Figure 5.2 RPM based Fan Control Algorithm**

### 5.3.1 Programming the RPM based Fan Control Algorithm

The RPM based Fan Control Algorithm powers-up enabled and active. The following registers control the algorithm. The EMC2102 fan control registers are preloaded with defaults that will work for a wide variety of fans so only the TACH Target Register is required to set a fan speed. The other fan control registers can be used to fine-tune the algorithm behavior based on application requirements.

1. Set the Valid TACH Count Register to the minimum TACH count that indicates the fan is spinning.
2. Set the Spin Up Configuration Register to the spin up level and Spin Time desired.
3. Set the Fan Step Register to the desired step size.
4. Set the Fan Minimum Drive Register to the minimum drive value that will maintain fan operation.
5. Set the Update Time, and Edges options in the Fan Configuration Register.
6. Set the TACH Target Register to the desired TACH count.

### 5.3.2 TACH Measurement

In both modes of operation, the TACH measurement will work normally. Any TACH count that is higher than the Valid TACH Count (see [Section 6.17](#)) will flag a stalled fan and trigger an interrupt.

The EMC2102 includes a TACH measurement circuit. The TACH signal must be valid at all times to ensure proper operation. The TACH measurement circuitry is programmable to detect the fan speed of a variety of fan configurations and architectures including 1-pole, 2-pole (default), 3-pole, and 4-pole fans.

**APPLICATION NOTE:** The TACH measurement works independently of the drive settings. If the device is put into manual mode and the fan drive is set at a level that is lower than the fan can operate (including zero drive), then the TACH measurement may signal a Stalled Fan condition and assert an interrupt.

#### 5.3.2.1 Stalled Fan

If the TACH counter exceeds the user-programmable Valid TACH Count setting then it will flag the fan as stalled and trigger an interrupt. If the RPM based Fan Control Algorithm is enabled, the algorithm will automatically attempt to restart the fan until it detects a valid TACH level or is disabled.

The FAN\_STALL Status bit indicates that a stalled fan was detected. This bit is checked conditionally depending on the mode of operation.

- Whenever the Manual Mode is enabled, the FAN\_STALL interrupt will be masked for the duration of the programmed Spin Up Time (see [Table 6.21](#)) to allow the fan opportunity to reach a valid speed without generating unnecessary interrupts.
- In Manual Mode, whenever the drive value is changed from 00h, the FAN\_STALL interrupt will be masked for the duration of the programmed Spin Up Time to allow the fan opportunity to reach a valid speed without generating unnecessary interrupts.
- In Manual Mode, whenever the TACH count exceeds the Valid TACH Count Register setting, the FAN\_STALL status bit will be set.
- When the RPM based Fan Control Algorithm, the stalled fan condition is checked whenever the Update Time is met and the fan drive setting is updated. It is not a continuous check.

### 5.3.3 Spin Up Routine

The EMC2102 also contains programmable circuitry to control the spin up behavior of the fan driver to ensure proper fan operation. During Manual Mode, the Spin Up Routine will not control the fan drive settings under any conditions.

When the RPM based Fan Control Algorithm is running, the Spin Up Routine is initiated under the following conditions:

**APPLICATION NOTE:** When the device is operating in manual mode, the FAN\_SPIN status bit may be set if the fan drive is set at a level that is lower than the fan can operate (including zero drive). If the FAN\_SPIN interrupt is unmasked, then this condition will trigger an errant interrupt.

1. The TACH Target Register value changes from a value of FFh to a value that is less than the Valid TACH Count (see [Section 6.18](#) and [Section 6.17](#)).
2. At power-up if the FAN\_MODE setting is '1' or 'open' indicating 75% drive or 60% drive respectively. If the FAN\_MODE setting is '0' indicating 0% drive, then the Spin Up Routine is not initiated until another condition is met.
3. The RPM based Fan Control Algorithm is started and the FAN\_MODE setting is '0' indicating 0% drive prior to algorithm control.
4. The RPM based Fan Control Algorithm's measured TACH count is greater than the Valid TACH Count.

When the Spin Up Routine is operating, the fan driver is set to full scale for one quarter of the total user defined spin up time. For the remaining spin up time, the fan driver output is set a a user defined level (60% or 75% drive).

After the Spin Up Routine has finished, the EMC2102 measures the TACH. If the measured TACH count is higher than the Valid TACH Count Register setting, the FAN\_SPIN status bit is set and the Spin Up Routine will automatically attempt to restart the fan.

[Figure 5.3](#) shows an example of the Spin Up Routine in response to a programmed fan speed change based on the first condition above.

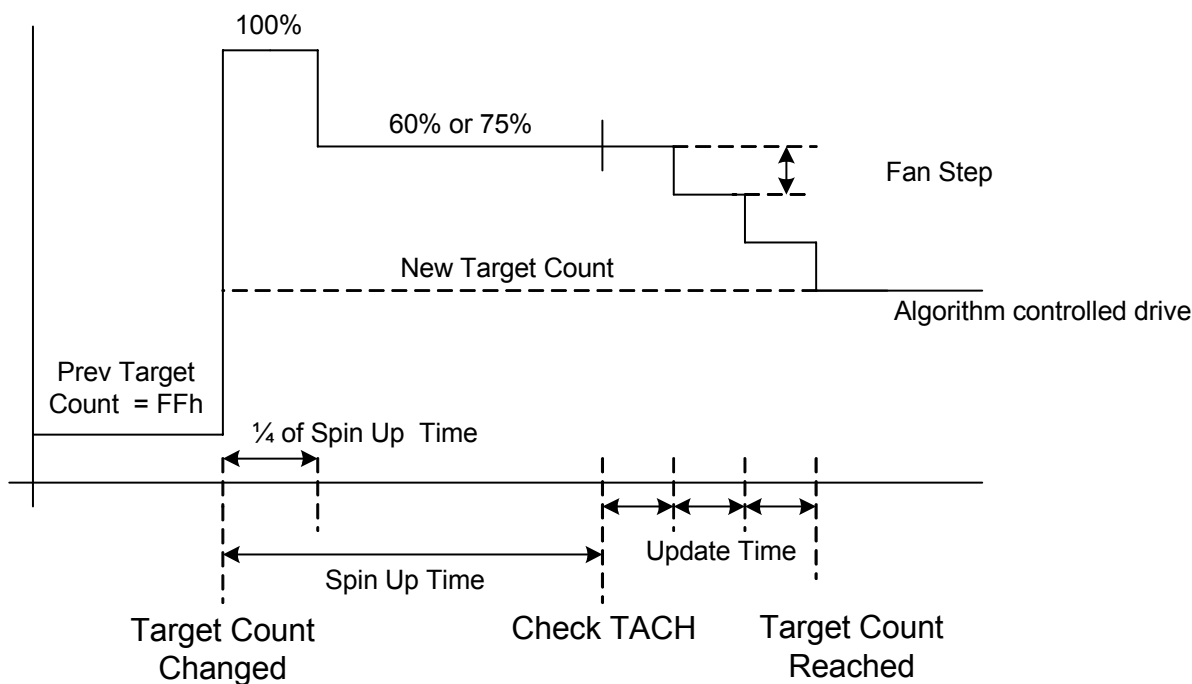

**Figure 5.3 Spin Up Routine**



### 5.3.4 FAN\_MODE Pin

The FAN\_MODE pin is used to determine the fan driver output levels at power-up before the EMC2102 has been programmed. After power-up, the fan driver will be set at the selected drive until the RPM based Fan Control Algorithm is started or disabled.

The level on the pin determines the function as shown in [Table 5.2](#).

**Table 5.2 FAN\_MODE Pin Functions**

FAN_MODE	FUNCTION
0	Fan Driver set at 0% drive
open	Fan Driver set at 60% drive after Spin Up Routine
1	Fan Driver set at 75% drive after Spin Up Routine

### 5.3.5 32.768KHz Clock Source

The EMC2102 allows the user to choose between supplying an external 32.768KHz clock or use of the internal 32.768KHz oscillator to measure the TACH signal. This clock source is used by the RPM based Fan Control Algorithm to calculate the current fan speed. This fan controller accuracy is directly proportional to the accuracy of the clock source.

To enable the external clock source, the CLK\_SEL pin must be pulled to VDD\_3V at power-up (see [Table 5.3](#)). The CLK\_SEL pin is must be in a known state at all times (either pulled high or pulled low) and is latched upon power-up.

**Table 5.3 CLK\_SEL Pin Functions**

CLK_SEL	FUNCTION
0	Internal oscillator used
1	External clock used

## 5.4 Watchdog Timer

The EMC2102 contains an internal Watchdog Timer. Once the device has powered up the watchdog timer monitors the bus traffic for signs of activity. The Watchdog Timer starts when the VDD\_5V supply has reached its operating point. The Watchdog Timer only starts immediately after power-up and once it has been triggered or deactivated will not restart.

If four (4) seconds elapse without the system host programming the device, then the following will occur:

1. The WATCH status bit will be set.
2. The High Side Fan Driver will be set to full scale drive. It will remain at full scale drive until one of the two conditions listed below are met.

If the Watchdog Timer is triggered, the following two operations will disable the timer and return the device to normal operation.

1. Writing the RPM based Fan Control Algorithm TACH Target Register will disable the Watchdog Timer regardless of the value. If a value is written that is greater than the Valid TACH Count Register setting (other than FFh), the fan drive setting will be set based on the FAN\_MODE pin

condition (0%, 60% or 75% drive). If a value of FFh is written, then the fan driver will be disabled until a valid setting is written.

- Disabling the RPM based Fan Control Algorithm by clearing the EN bit will disable the Watchdog Timer. The fan driver will be set to the programmed setting written in the Fan Driver Setting Register.

Writing any other configuration registers will not disable the Watchdog Timer. If the VDD\_5V supply drops below the reset threshold, then the Watchdog Timer will be stopped but not reset.

## 5.5 High Side Fan Driver

The EMC2102's fan controller integrates a 5V, 600mA, linear high side fan driver to directly drive a 5V fan. By fully integrating the linear fan driver, the typical requirement for the discrete pass device and other external linearization circuitry is completely eliminated. The linear fan driver is driven by an 8-bit DAC providing better than 20mV resolution between steps.

### 5.5.1 Overcurrent Limit

The High Side Fan Driver contains circuitry to allow for significant overcurrent levels to accommodate transient conditions on the FAN pins. The overcurrent limit is dependent upon the output voltage with the limit dropping as the voltage nears 0V.

If the fan driver current detects a short-circuit condition for longer than 2 seconds, then the I\_SHORT status bit is set and an interrupt generated. Additionally, the fan driver will be disabled (by setting the drive level to 00h).

In both Manual Mode and when using the RPM based Fan Control Algorithm, the device will attempt to restart the fan after a time equal to the spin-up time programmed in the Fan Spin Up Configuration Register (see [Section 6.14](#)). If the High Side Fan Driver is configured to operate in Manual Mode, when it attempts to restart the fan after an overcurrent condition, it will set the Fan Drive Setting Register to the most recently written value (prior to the overcurrent condition). If the High Side Fan Driver is configured to use the RPM based Fan Control Algorithm, it will invoke the Spin Up Routine described in [Section 5.3.3](#).

If the overcurrent condition persists, the fan driver will continue to attempt to restart the fan until the overcurrent condition is removed or the High Side Fan Driver is disabled by setting the TACH Target to FFh (when using the RPM based Fan Control Algorithm) or by writing the Fan Setting Register to a value of 00h (when operating in Manual Mode)

## 5.6 Internal Thermal Shutdown (TSD)

The EMC2102 contains an internal thermal shutdown circuit that monitors the internal die temperature. If the die temperature exceeds the Thermal Shutdown Threshold (see [Table 3.2](#)), then the following will occur:

- The High Side Fan Driver is disabled. It will remain disabled until the internal temperature drops below the threshold temperature minus 50°C.
- The TSD Status bit will be set and the  $\overline{\text{ALERT}}$  pin asserted. This signal cannot be masked.
- The  $\overline{\text{SYS\_SHDN}}$  pin is asserted.

## 5.7 Critical/Thermal Shutdown

The EMC2102 provides a hardware Critical/Thermal Shutdown function for systems. [Figure 5.4](#) is a block diagram of this Critical/Thermal Shutdown function. The Critical/Thermal Shutdown function in the EMC2102 consists of both analog and digital functions. It accepts digital inputs from the CPU

Datasheet

(THERMTRIP#) and power supply (POWER\_OK) and configuration information from the fixed states of the SHDN\_SEL pins as described in Section 5.7.2.

In addition, each of the temperature limits can be configured to act as inputs to the Critical / Thermal Shutdown independent of the hardware shutdown operation.

The analog portion of the Critical/Thermal Shutdown function monitors a specific remote temperature channel (configured with the SHDN\_SEL pin). This measured temperature is then compared with the TRIP\_SET point. This TRIP\_SET point is created by the system designer with a simple resistor divider and is discussed in detail in Section 5.7.1.

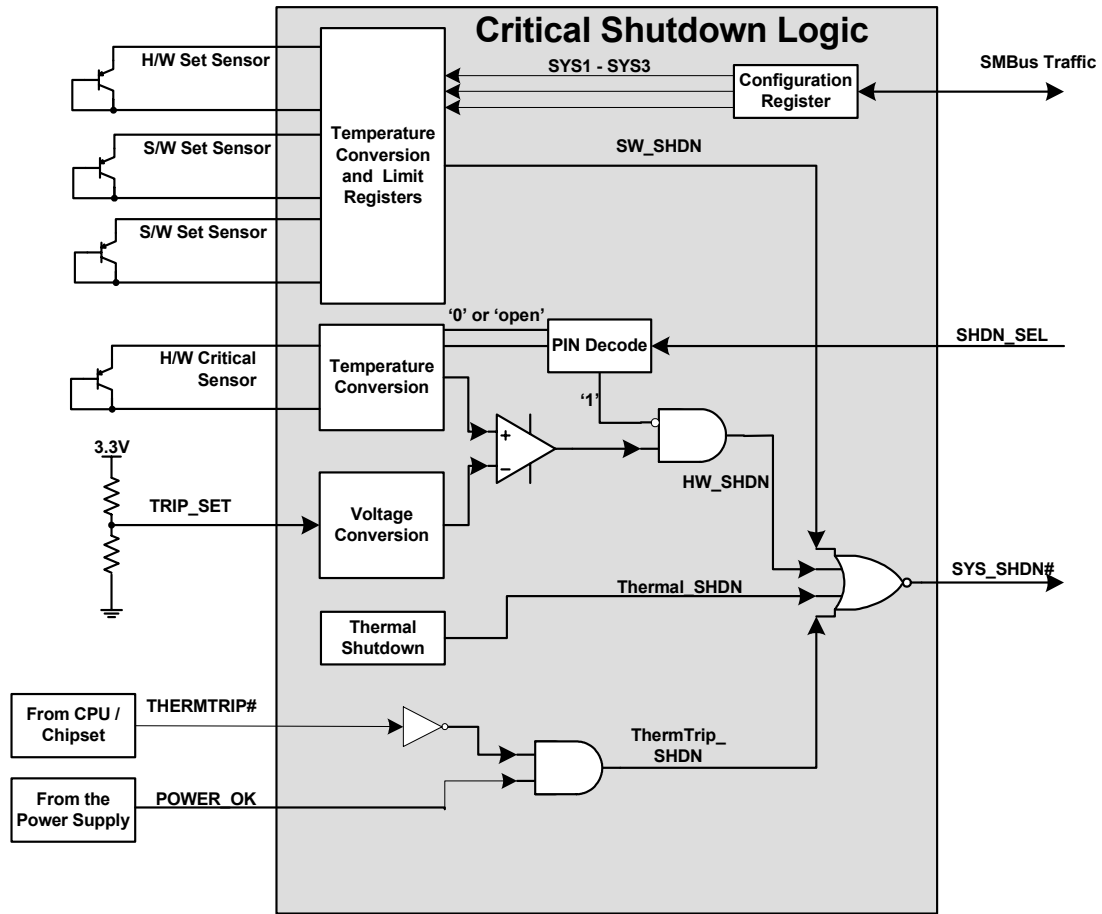

ThermTrip#	Power_OK	ThermTrip_SHDN
0	0	0
0	1	1
1	0	0
1	1	0

Figure 5.4 EMC2102 Critical/Thermal Shutdown Block Diagram

### 5.7.1 TRIP\_SET

The EMC2102's TRIP\_SET pin is an analog input to the Critical/Thermal Shutdown block which sets the Thermal Shutdown temperature. The system designer creates a voltage level at this input through a simple resistor divider between the 3.3V supply and GND. This input voltage is valid between 0V and 1.5V which corresponds to Thermal Shutdown temperature setpoints between 75°C and 106°C as described in the following equation.

$$TRIP\_SET \text{ Pin Voltage} = \frac{T_{TRIP} - 75}{21}$$

Where:

$T_{TRIP}$  is the desired trip point temperature

[1]

TRIPSET is the voltage on the TRIP\_SET pin

### 5.7.2 SHDN\_SEL Pin

The EMC2102 has one 'strappable' input (SHDN\_SEL) allowing for configuration of the hardware Critical/Thermal Shutdown. This pin has 3 possible states and is monitored and decoded by the EMC2102 at power-up. The three possible states are 0 (tied to GND), 1 (tied to 3.3V) or High-Z (open). The states of this pin determine which remote temperature channel and configuration is used by the Critical/Thermal Shutdown function. The different configurations of SHDN\_SEL pin are described in [Table 5.4](#)

A channel that is configured via the SHDN\_SEL pin for the Critical/Thermal Shutdown is locked and none of the configuration registers associated with it can be updated via the SMBus. The other two temperature channels, however, are still configurable via the SMBus.

**Table 5.4 SHDN\_SEL Pin Configuration**

SHDN_SEL	FUNCTION NAME	REMOTE CHANNEL INPUT TO THERMAL SHUTDOWN	CRITICAL/THERMAL SHUTDOWN DETAILS
0	Intel Mode	1	Channel 1 is configured and locked with both Beta Compensation and Resistance Error Correction enabled which is optimized for an Intel thermal diode.
High-Z	Diode Mode	3	Channel 3 is configured and locked with Resistance Error Correction enabled which is optimal for interfacing a discrete diode-connected NPN transistor.
1	Disabled,	NA	The Critical/Thermal Shutdown function will not assert SYS_SHDN# based on a temperature channel. This does not include software configured inputs (see <a href="#">Section 6.4</a> )

## Datasheet

### 5.7.3 Internal HW\_SHDN Signal

The HW\_SHDN output from the Critical/Thermal Shutdown Monitor is a logical indicator of the temperature state of the chosen external diode channel. HW\_SHDN is an internal signal routed as an input to the Thermal / Critical Shutdown logic.

The HW\_SHDN output is set to logic '1' when the indicated temperature exceeds the temperature threshold ( $T_P$ ) established by the TRIP\_SET input pin (as shown in [Figure 5.5](#)) for a number of consecutive measurements defined by the fault queue. If the HW\_SHDN output is asserted and the temperature drops below  $T_P$ , then it will be set to a logic '0' state.

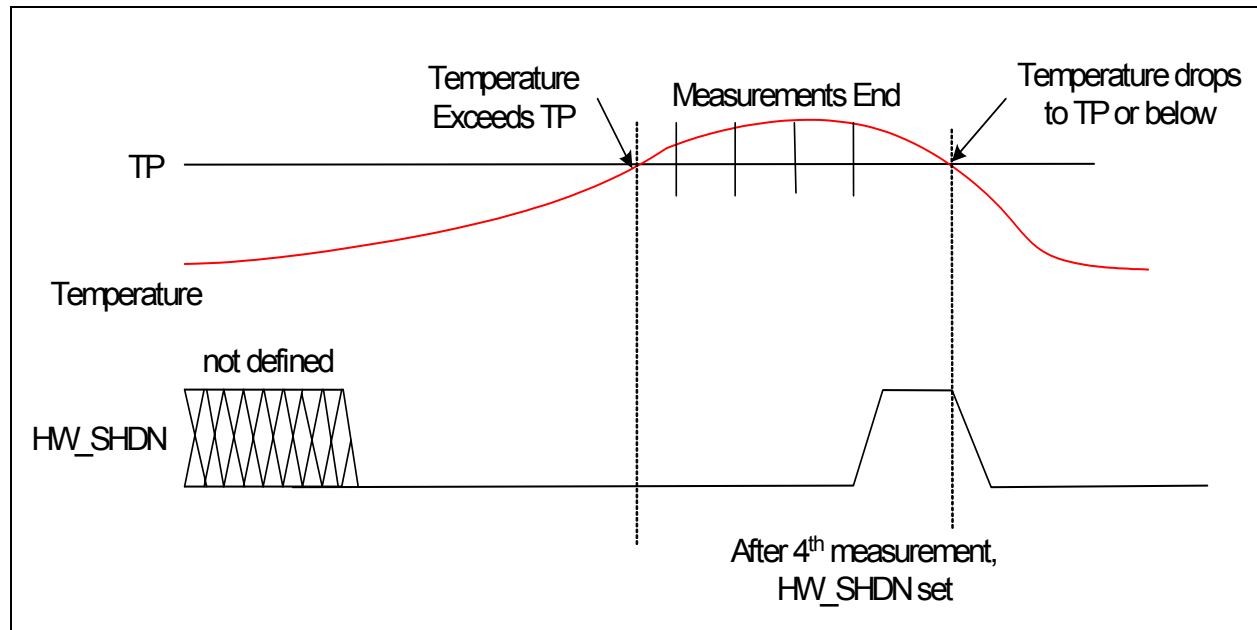
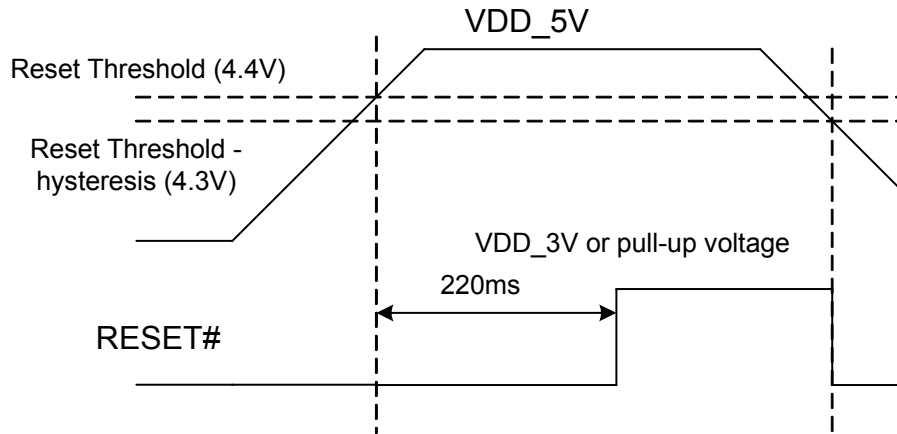

Figure 5.5 HW\_SHDN Operation

## 5.8 5V Reset Controller

The EMC2102 also provides a 'power-good' reset controller for the system's 5V supply rail. The reset controller will set the RESET# pin to a logic '0' after power-up and set the RESET# pin to a logic '1' 220ms after the VDD\_5V supply rises above its threshold voltage (see [Table 3.2](#)).

If the VDD\_5V supply drops below the reset threshold, then the RESET# pin will be set to '0' immediately.



**Figure 5.6 5V Reset Controller Timing**

## Chapter 6 Register Set

### 6.1 Register Map

The following registers are accessible through the SMBus Interface. All register bits marked as '-' will always read '0'. A write to these bits will have no effect.

**Table 6.1 EMC2102 Register Set**

ADDR	R/W	REGISTER NAME	FUNCTION	DEFAULT VALUE	LOCK	PAGE
Temperature Registers						
00h	R	Internal Temp Reading	Stores the integer data of the Internal Temp Reading	00h	No	Page 33
01h	R	External Diode 1 Temp Reading	Stores the integer data of External Diode 1	00h	No	Page 33
02h	R	External Diode 2 Temp Reading	Stores the integer data of External Diode 2	00h	No	
03h	R	External Diode 3 Temp Reading	Stores the integer data of External Diode 3	00h	No	
04h	R	Critical/Thermal Shutdown Temperature	Stores the calculated Critical/Thermal Shutdown temperature high limit derived from the voltage on TRIP_SET.	7Fh	No	Page 34
Configuration and control						
20h	R/W	Configuration	Configures the Thermal / Critical Shutdown masking options and software lock	80h	SWL	Page 34
21h	R/W	Conversion Rate	Configures the conversion rate	02h	SWL	Page 35
22h	R-C	Interrupt Status Register 1	Stores the status bits for temperature channels	80h	No	Page 36
23h	R-C	Interrupt Status Register 2	Stores the status bits for the thermal shutdown and RPM based Fan Control Algorithm	00h	No	Page 37
24h	R/W	Interrupt Mask Register	Controls the masking of interrupts on all maskable channels	10h	No	Page 37
Diode Configuration						
30h	R/W	External Diode 1 Beta Configuration	Configures the beta compensation settings for External Diode 1	03h	SWL	Page 38
31h	R/W	External Diode 2 Beta Configuration	Configures the beta compensation settings for External Diode 2	03h	SWL	
32h	R/W	External Diode REC Configuration	Configures the Resistance Error Correction functionality for all external diodes	07h	SWL	Page 39

**Table 6.1 EMC2102 Register Set (continued)**

ADDR	R/W	REGISTER NAME	FUNCTION	DEFAULT VALUE	LOCK	PAGE
Temperature Limit Registers						
41h	R/W	External Diode 1 Temp High Limit	High limit for External Diode 1	55h (+85°C)	SWL	Page 40
42h	R/W	External Diode 2 Temp High Limit	High limit for External Diode 2	55h (+85°C)	SWL	
43h	R/W	External Diode 3 Temp High Limit	High limit for External Diode 3	55h (+85°C)	SWL	
Fan Control Registers						
51h	R/W	Fan Driver Setting	Always displays the most recent fan driver input setting. If the RPM based Fan Control Algorithm is disabled, allows direct user control of the fan driver.	00h	No	Page 40
52h	R/W	Fan Configuration	Sets configuration values for the RPM based Fan Control Algorithm	CBh	No	Page 41
53h	R/W	Fan Spin Up Configuration	Sets the configuration values for Spin Up Routine of the High Side Fan Driver	01h	SWL	Page 42
54h	R/W	Fan Step	Sets the maximum change per update for the High Side Fan Driver	10h	SWL	Page 43
55h	R/W	Fan Minimum Drive	Sets the minimum drive value for the High Side Fan Driver	80h	SWL	Page 43
56h	R/W	Fan Valid TACH Count	Holds the minimum TACH value that indicates the fan is spinning properly	F5h	SWL	Page 44
57h	R/W	TACH Target	Holds the target TACH count for the fan	FAh	No	Page 44
58h	R	TACH Reading	Holds the TACH count for the fan	FFh	No	Page 44
Revision Registers						
FDh	R	Product ID	Stores the unique Product ID	14h	No	Page 45
FFh	R	Revision	Revision	00h	No	Page 45

During Power-On-Reset (POR), the default values are stored in the registers. A POR is initiated when power is first applied to the part and the voltage on the VDD\_3V supply surpasses the POR level as specified in the electrical characteristics. Any reads to undefined registers will return 00h. Writes to undefined registers will not have an effect.

### 6.1.1 Lock Entries

The Lock Column describes the locking mechanism, if any, used for individual registers. All SWL registers are Software Locked and therefore made read-only when the LOCK bit is set.



## 6.2 Temperature Data Registers

Table 6.2 Temperature data Registers

ADDRESS	REGISTER	B7	B6	B5	B4	B3	B2	B1	B0	DEFAULT
00h	Internal Diode	Sign	64	32	16	8	4	2	1	00h
01h	External Diode 1	Sign	64	32	16	8	4	2	1	00h
02h	External Diode 2	Sign	64	32	16	8	4	2	1	00h
03h	External Diode 3	Sign	64	32	16	8	4	2	1	00h

The temperature measurement range is from 0°C to +191°C. The data format can be selected between pure 2's complement format which displays data from 0°C to +127°C, or in offset 2's complement format that displays data over the entire data range. The temperature format is shown below:

Table 6.3 Temperature Data Format

TEMPERATURE (°C)	2'S COMPLEMENT FORMAT		OFFSET 2'S COMPLEMENT FORMAT	
	BINARY	HEX	BINARY	HEX
Diode Fault	1000 0000	80h	1000 0000	80h
<= 0	0000 0000	00h	1100 0000	C0h
1	0000 0001	01h	1100 0001	C1h
63	0011 1111	3Fh	1111 1111	FFh
64	0100 0000	40h	0000 0000	00h
65	0100 0001	41h	0000 0001	01h
127	0111 1111	7Fh	0011 1111	3Fh
128 (Note 6.1)	0111 1111	7Fh	0100 0000	40h
190	0111 1111	7Fh	0111 1110	7Eh
191	0111 1111	7Fh	0111 1111	7Fh

**Note 6.1** In 2's complement format, any temperature above +127°C will be displayed as +127°C

If the High Side Fan Driver is active, then self-heating of the large current drive device will affect the internal temperature reading. Therefore, it is not recommended that the Internal temperature channel be used to monitor the ambient air temperature.

## 6.3 Critical/Thermal Shutdown Temperature Register

**Table 6.4 Critical/Thermal Shutdown Temperature Register**

ADDRESS	REGISTER	B7	B6	B5	B4	B3	B2	B1	B0	DEFAULT
04h	Critical/Thermal Shutdown Temperature	Sign	64	32	16	8	4	2	1	7Fh (+127°C)

The Critical/Thermal Shutdown Temperature Register is a read-only register that stores the Voltage Programmable Threshold temperature used in the Thermal / Critical Shutdown circuitry. The contents of the register reflect the calculated temperature based on the TRIP\_SET voltage. This register is updated at the end of every monitoring cycle based on the current value of TRIP\_SET. The register value reflects the exact threshold temperature.

The data format will match the selected format of the temperature data registers as shown in [Table 6.3](#).

## 6.4 Configuration Register

**Table 6.5 Configuration Register**

ADDRESS	REGISTER	B7	B6	B5	B4	B3	B2	B1	B0	DEFAULT
20h	Configuration	QUEUE[1:0]	SYS3	SYS2	SYS1	FORMAT	-	LOCK		80h

The Configuration Register controls the basic functionality of the EMC2102. The bits are described below. The Configuration Register is software locked.

Bit 7-6 - QUEUE[1:0] - determines how many consecutive out-of-limit errors must occur on the hardware selected and software enabled temperature channels before the SYS\_SHDN# pin is asserted (see [Table 5.2](#)). The queue applies to all enabled channels simultaneously and will trigger the SYS\_SHDN# pin if there are four consecutive measurements with any or all channels exceeding their corresponding limits.

**Table 6.6 Fault Queue**

QUEUE[1:0]		NUMBER OF FAULTS
1	0	
0	0	1
0	1	2
1	0	4 (default)
1	1	8

Bit 5 - SYS3 - enables the high temperature limit for the External Diode 3 channel to trigger the Critical / Thermal Shutdown circuitry (see [Section 5.7](#)).

- '0' (default) - the External Diode 3 channel high limit will not be linked to the SYS\_SHDN# pin. If the temperature exceeds the limit, the ALERT# pin will be asserted normally.

**Datasheet**

- '1' - the External Diode 3 channel high limit will be linked to the SYS\_SHDN# pin. If the temperature exceeds the limit then the SYS\_SHDN# pin will be asserted. The ALERT# pin will be asserted normally.

Bit 4 - SYS2 - enables the high temperature limit for the External Diode 2 channel to trigger the Critical / Thermal Shutdown circuitry (see [Section 5.7](#)).

- '0' (default) - the External Diode 2 channel high limit will not be linked to the SYS\_SHDN# pin. If the temperature exceeds the limit, the ALERT# pin will be asserted normally.
- '1' - the External Diode 2 channel high limit will be linked to the SYS\_SHDN# pin. If the temperature exceeds the limit then the SYS\_SHDN# pin will be asserted. The ALERT# pin will be asserted normally.

Bit 3 - SYS1 - enables the high temperature limit for the External Diode 1 channel to trigger the Critical / Thermal Shutdown circuitry (see [Section 5.7](#)).

- '0' (default) - the External Diode 1 channel high limit will not be linked to the SYS\_SHDN# pin. If the temperature exceeds the limit, the ALERT# pin will be asserted normally.
- '1' - the External Diode 1 channel high limit will be linked to the SYS\_SHDN# pin. If the temperature exceeds the limit then the SYS\_SHDN# pin will be asserted. The ALERT# pin will be asserted normally.

Bit 2 - FORMAT - determines the data format that is displayed in the Temperature Data Registers. The data format for the Critical Thermal Shutdown Threshold Register will not be changed. If the temperature data format is changed, the limit register values must be changed to match the newer format.

- '0' (default) - the temperature data will be in standard 2's complement format.
- '1' - the temperature data will be in offset 2's complement format.

Bit 0 - LOCK - this bit acts on all registers that are designated SWL. When this bit is set, the locked registers become read only and cannot be updated.

- '0' (default) - all SWL registers can be updated normally.
- '1' - all SWL registers cannot be updated and a hard-reset is required to unlock them.

## 6.5 Conversion Rate Register

**Table 6.7 Conversion Rate Register**

ADDRESS	REGISTER	B7	B6	B5	B4	B3	B2	B1	B0	DEFAULT
21h	Conversion Rate	-	-	-	-	-	-	CONV[1:0]		02h

The Conversion Rate Register controls the conversion rate of the temperature monitoring as well as the fault queue. The Conversion Rate Register is software locked.

Bit 1 - 0 - CONV[1:0] - determines the conversion rate of the temperature monitoring. This conversion rate does not affect the fan driver. The supply current from VDD\_3V is nominally dependent upon the conversion rate and the average current will increase as the conversion rate increases.

**Table 6.8 Conversion Rate**

CONV[1:0]		CONVERSION RATE
1	0	
0	0	1 / sec
0	1	2 / sec
1	0	4 / sec (default)
1	1	8 / sec

## 6.6 Interrupt Status Register 1

**Table 6.9 Interrupt Status Register 1**

ADDRESS	REGISTER	B7	B6	B5	B4	B3	B2	B1	B0	DEFAULT
22h	Interrupt Status Register 1	RESET	TSD	ERR3	TRD3	ERR2	TRD2	ERR1	TRD1	80h

The Interrupt Status Registers report the operating condition of the EMC2102. If any of the bits are set to a logic '1' (other than the RESET pin) then the ALERT# pin will be asserted low. Reading from the status register clears all status bits if the error conditions is removed. If there are no set status bits, then the ALERT# pin will be released.

The bits that cause the ALERT# pin to be asserted can be masked based on the channel they are associated with unless stated otherwise.

Bit 7 - RESET - this bit mirrors the output of the RESET# pin. When the RESET# pin is set to a logic '0' (indicating that the VDD\_5V supply is lower than the reset threshold), this bit is set to a logic '1' as well. This bit will not cause the ALERT# pin to be asserted.

Bit 6 - TSD - this bit is asserted '1' if there is a thermal shutdown condition. This bit cannot be masked.

Bit 5 - ERR3 - this bit is asserted '1' if there is a diode fault on External Diode 3.

Bit 4 - TRD3 - this bit is asserted '1' if the External Diode 3 Temperature measurement exceeds the high limit.

Bit 3 - ERR2 - this bit is asserted '1' if there is a diode fault on External Diode 2.

Bit 2 - TRD2 - this bit is asserted '1' if the External Diode 2 Temperature measurement exceeds the high limit.

Bit 1 - ERR1 - this bit is asserted '1' if there is a diode fault on External Diode 1.

Bit 0 - TRD1 - this bit is asserted '1' if the External Diode 1 Temperature measurement exceeds the high limit.

## 6.7 Interrupt Status Register 2

Table 6.10 Interrupt Status Register 2

ADDRESS	REGISTER	B7	B6	B5	B4	B3	B2	B1	B0	DEFAULT
23h	Interrupt Status Register 2	PWROK	THERM	HWS	-	WATCH	FAN_SPIN	FAN_STALL	I_SHORT	00h

The Interrupt Status Registers report the operating condition of the EMC2102. If any of the bits (except the PWROK, THERM, and HWS bits) are asserted then the ALERT# pin will be asserted low. Reading from the status register clears all status bits if the error conditions is removed. If there are no set status bits, then the ALERT# pin will be released.

Bit 7 - PWROK - this bit is set if the POWER\_OK pin is set to a logic '1' state. When this bit is set, it will not cause the ALERT# pin to be asserted.

Bit 6 - THERM - this bit is set if the THERMTRIP# pin is set to a logic '0' state. When this bit is set, it will not cause the ALERT# pin to be asserted however will coincide with SYS\_SHDN# pin being asserted. The THERMTRIP# pin can only cause the SYS\_SHDN# pin to be asserted if the POWER\_OK pin is set to a logic '1' (see [Figure 5.4](#)).

Bit 5 - HWS - this bit is set if the internal HW\_SHDN signal is set (see [Section 5.7.3](#)) based on the TRIP\_SET voltage and the SHDN\_SEL pin conditions. When this bit is set, it will not cause the ALERT# pin to be asserted however will coincide with SYS\_SHDN# pin being asserted.

Bit 3 - WATCH - this bit is asserted '1' if the Watchdog Timer circuit does not detect the fan being programmed within 4 seconds after power-up. This bit cannot be masked.

Bit 2 - FAN\_SPIN - this bit is asserted '1' if the Spin up Routine for Fan cannot detect a valid TACH within its maximum time window. This bit can be masked from asserting the ALERT# pin.

Bit 1 - FAN\_STALL - this bit is asserted '1' if the TACH measurement on fan detects a stalled fan. This bit can be masked from asserting the ALERT# pin.

Bit 0 - I\_SHORT - this bit is asserted '1' if the High Side Fan Driver circuit detects a short circuit condition. This bit cannot be masked.

## 6.8 Interrupt Mask Register

Table 6.11 Interrupt Mask Register

ADDRESS	REGISTER	B7	B6	B5	B4	B3	B2	B1	B0	DEFAULT
24h	Interrupt Mask	-	-	-	SPIN_MASK	STALL_MASK	EXT3_MSK	EXT2_MSK	EXT1_MSK	10h

The Interrupt Mask Register controls the masking for each temperature channel and the TACH monitor. When a channel is masked, it will not cause the ALERT# pin to be asserted when an error condition is detected.

Bit 4 - SPIN\_MASK - masks the FAN\_SPIN bit from asserting the ALERT# pin.

- '0' - the FAN\_SPIN bit will assert the ALERT# pin if set in the Interrupt Status Register 2.
- '1' - (default) - the FAN\_SPIN bit will not assert the ALERT# pin though will still update the Interrupt Status Register 2 normally.

Bit 3 - STALL\_MASK - masks the FAN\_STALL bit from asserting the ALERT# pin.

- '0' (default) - the FAN\_STALL bit will assert the ALERT# pin if set in the Interrupt Status Register 2.
- '1' - the FAN\_STALL bit will not assert the ALERT# pin though will still update the Interrupt Status Register 2 normally.

Bit 2 - EXT3\_MASK - masks the ERR3 and TRD3 bits from asserting the ALERT# pin.

- '0' (default) - the ERR3 and TRD3 bits will assert the ALERT# pin if they are set in the Interrupt Status Register 1.
- '1' - the ERR3 and TRD3 bits will not assert the ALERT# pin though they will still update the Interrupt Status Register 1 normally.

Bit 1 - EXT2\_MASK - masks the ERR2 and TRD2 bits from asserting the ALERT# pin.

- '0' (default) - the ERR2 and TRD2 bits will assert the ALERT# pin if they are set in the Interrupt Status Register 1.
- '1' - the ERR2 and TRD2 bits will not assert the ALERT# pin though they will still update the Interrupt Status Register 1 normally.

Bit 0 - EXT1\_MASK - masks the ERR1 and TRD1 bits from asserting the ALERT# pin.

- '0' (default) - the ERR1 and TRD1 bits will assert the ALERT# pin if they are set in the Interrupt Status Register 1.
- '1' - the ERR1 and TRD1 bits will not assert the ALERT# pin though they will still update the Interrupt Status Register 1 normally.

## 6.9 Beta Configuration Registers

**Table 6.12 Beta Configuration Registers**

ADDRESS	REGISTER	B7	B6	B5	B4	B3	B2	B1	B0	DEFAULT
30h	External Diode 1 Beta Configuration	-	-	-	-	-	BETA1[2:0]			03h
31h	External Diode 2 Beta Configuration	-	-	-	-	-	BETA2[2:0]			03h

The Beta Configuration Registers control advanced temperature measurement features for each External Diode channel. The Beta Configuration Registers are software locked.

When the External Diode 1 Channel is selected by the SHDN\_SEL pin to be the hardware shutdown input channel (see [Table 5.4](#)), the External Diode 1 Beta Configuration Register becomes read only. Writing to the register will have no affect and reading from it will always reflect the current beta settings (05h).

For the External Diode 3 Channel, the beta compensation setting is fixed at '111b' indicating that the beta compensation is disabled.

Bit 2 - 0 - BETAx[2:0] - hold a value that corresponds to a range of betas that the Beta Compensation circuitry can compensate for. The Beta Configuration Registers activate the Beta Compensation circuitry if any value besides 111 is written. The register should be set with a value corresponding to the lowest expected value of beta for the PNP transistor being used as a temperature sensing device.

See [Table 6.13](#) for supported beta ranges. The default setting is calibrated for 65nm CPU's. For 90nm CPU's the optimal beta setting is 04h.

## Datasheet

When the Beta Compensation circuitry is disabled, the diode channels will function with default current levels and will not automatically adjust for beta variation. This mode is used when measuring a discrete 2N3904 transistor or AMD thermal diode.

All of the Beta Configuration Registers are Software Locked.

**Table 6.13 Beta Compensation Look Up Table**

BETAX[2:0]			MINIMUM BETA
2	1	0	
0	0	0	0.1111
0	0	1	0.1765
0	1	0	0.25
0	1	1	0.333 (default)
1	0	0	0.4285
1	0	1	1.0
1	1	0	2.333
1	1	1	Disabled

## 6.10 REC Configuration Register

**Table 6.14 REC Configuration Register**

ADDRESS	REGISTER	B7	B6	B5	B4	B3	B2	B1	B0	DEFAULT
32h	REC Configuration	-	-	-	-	-	REC3	REC2	REC1	07h

The REC Configuration Register determines whether Resistance Error Correction is used for each external diode channel. The REC Configuration Register is software locked.

If either the External Diode 1 channel or External Diode 3 channel is selected by the SHDN\_SEL pin to be the hardware shutdown input channel (see [Table 5.4](#)), then the corresponding REC<sub>x</sub> bit will be locked. Writing to the bit will have no affect and reading from it will always report the current setting.

Bit 2 - REC3 - Controls the Resistive Error Correction functionality of External Diode 3

- '0' - the REC functionality for External Diode 3 is disabled
- '1' (default) - the REC functionality for External Diode 3 is enabled.

Bit 1 - REC2 - Controls the Resistive Error Correction functionality of External Diode 1

- '0' - the REC functionality for External Diode 2 is disabled
- '1' (default) - the REC functionality for External Diode 2 is enabled.

Bit 0 - REC1 - Controls the Resistive Error Correction functionality of External Diode 1

- '0' - the REC functionality for External Diode 1 is disabled
- '1' (default) - the REC functionality for External Diode 1 is enabled.

## 6.11 Temperature Limit Registers

**Table 6.15 Temperature Limit Registers**

ADDRESS	REGISTER	B7	B6	B5	B4	B3	B2	B1	B0	DEFAULT
41h	External Diode 1 High Limit	Sign	64	32	16	8	4	2	1	55h (+85°C)
42h	External Diode 2 High Limit	Sign	64	32	16	8	4	2	1	55h (+85°C)
43h	External Diode 3 High Limit	Sign	64	32	16	8	4	2	1	55h (+85°C)

The EMC2102 contains high limits for all temperature channels. If any particular temperature channel exceeds the high limit then the appropriate status bit is set.

Each temperature channel software limit can be individually enabled to assert the SYS\_SHDN# pin if the temperature exceeds this limit.

All Temperature Limit Registers are Software Locked.

## 6.12 Fan Driver Setting Register

**Table 6.16 Fan Driver Setting Register**

ADDRESS	REGISTER	B7	B6	B5	B4	B3	B2	B1	B0	DEFAULT
51h	Fan Driver Setting	128	64	32	16	8	4	2	1	00h

The Fan Driver Setting Register always displays the current setting of the High Side Fan Driver. If the RPM based Fan Control Algorithm is disabled, this register can be written to manually control the fan driver (manual mode). See [Section 5.2](#).

If this register is written to while the RPM based Fan Control Algorithm is active, it will not affect the current output drive. The value that is written will be retained however and used as the current drive if the RPM based Fan Control algorithm is disabled.

Reading from this register will report the current fan speed setting regardless of the operating mode. Therefore it is possible that reading from this register will not report data that was previously written into this register.

The contents of the register represent the weighting of each bit in determining the final output voltage. The output voltage is given by [Equation \[2\]](#).

$$FAN\_OUT = \left( \frac{VALUE}{255} \right) \times VDD\_5V \quad [2]$$



## 6.13 Fan Configuration Register

**Table 6.17 Fan Control Configuration Register**

ADDRESS	REGISTER	B7	B6	B5	B4	B3	B2	B1	B0	DEFAULT
52h	FAN Configuration	EN	LIMIT2K	-	EDGES[1:0]		UPDATE[2:0]			CBh

The Fan Configuration Register controls the general operation of the RPM based Fan Control Algorithm used for the High Side Fan Driver.

Bit 7 - EN - enables the RPM based Fan Control Algorithm.

- '0' - the control circuitry is disabled and the fan driver output is determined by the Fan Driver Setting Register.
- '1' (default) - the control circuitry is enabled and the Fan Driver output will be automatically updated to maintain the programmed fan speed as indicated by the TACH Target Register.

Bit 6 - LIMIT2K - Adjusts the range of reported and programmed TACH count values.

- '0' - the range of reported and programmable TACH values allows for a minimum speed of approximately 500 RPM with reduced resolution to report lower speed values.
- '1' (default) - the range of reported and programmable TACH values allows for a minimum speed of approximately 2000 RPM with increased resolution to report higher speed values.

Bit 4-3 - EDGES[1:0] - determines the minimum number of edges that must be detected on the TACH signal to determine a single rotation. A typical fan measured 5 edges (for a 2-pole fan). For more accurate TACH measurement, the minimum number of poles may be increased, however the TACH measurement will be artificially higher than expected as denoted in the Effective TACH multiplier. Additionally, some fans have more than 2-poles and therefore require more edges to be measured as shown in the Number of Fan Poles

The EDGES[1:0] bits are shown in [Table 6.18](#).

**Table 6.18 Minimum Edges for Fan Rotation**

EDGES[1:0]		MINIMUM TACH EDGES	NUMBER OF FAN POLES	EFFECTIVE TACH MULTIPLIER (BASED ON 2 POLE FANS)
1	0			
0	0	3	1 pole	0.6
0	1	5	2 poles (default)	1
1	0	7	3 poles	1.4
1	1	9	4 poles	1.8

Bit 2-0 - UPDATE - determines the base time between fan driver updates. The Update Time, along with the Fan Step Register, is used to control the ramp rate of the drive response to provide a cleaner transition of the actual fan operation as the desired fan speed changes. The Update Time is set as shown in [Table 6.19](#).

**Table 6.19 Update Time**

UPDATE[2:0]			UPDATE TIME
2	1	0	
0	0	0	100ms
0	0	1	200ms
0	1	0	300ms
0	1	1	400ms (default)
1	0	0	500ms
1	0	1	800ms
1	1	0	1200ms
1	1	1	1600ms

## 6.14 Fan Spin Up Configuration Register

**Table 6.20 Fan TACH Configuration Register**

ADDRESS	REGISTER	B7	B6	B5	B4	B3	B2	B1	B0	DEFAULT
53h	Fan Spin Up Configuration	-	-	-	-	-	LEVEL	SPINUP_TIME [1:0]		01h

The Fan Spin Up Configuration Register controls the settings of Spin Up Routine used by the RPM based Fan Control Algorithm. The Fan Spin Up Configuration Register is software locked.

Bit 2 - LEVEL - determines the spin up level that is used whenever the Spin Up Routine is initiated after power-up

- '0' (default) - the spin up level will be 60% of full scale.
- '1' - the spin up level will be 75% of full scale.

Bit 1 -0 - SPINUP\_TIME[2:0] - determines the maximum Spin Time that the Spin Up Routine will run for (see [Section 5.3.3](#)). If a valid TACH is not detected before the Spin Time has elapsed, then an interrupt will be generated. When the RPM based Fan Control Algorithm is active, the fan driver will attempt to re-start the fan immediately after the end of the last spin up attempt.

The Spin Time is set as shown in [Table 6.21](#).

**Table 6.21 Spin Time**

SPINUP_TIME[1:0]		TOTAL SPIN UP TIME
1	0	
0	0	250 ms
0	1	500 ms (default)

Table 6.21 Spin Time (continued)

SPINUP_TIME[1:0]		TOTAL SPIN UP TIME
1	0	
1	0	1 sec
1	1	2 sec

## 6.15 Fan Step Register

Table 6.22 Fan Step Register

ADDRESS	REGISTER	B7	B6	B5	B4	B3	B2	B1	B0	DEFAULT
54h	Fan Step	-	-	32	16	8	4	2	1	10h

The Fan Step Register, along with the Update Time, controls the ramp rate of the fan driver response calculated by the RPM based Fan Control Algorithm. The value of the register represents the maximum step size the fan driver will take between update times (see [Section 6.13](#)).

The Fan Step Register setting can be translated to a maximum voltage step as shown in [Equation \[2\]](#).

If the necessary fan driver delta is larger than the Fan Step, it will be capped at the Fan Step setting and updated every Update Time ms.

The Fan Step Register is software locked.

## 6.16 Fan Minimum Drive Register

Table 6.23 Minimum Fan Drive Register

ADDRESS	REGISTER	B7	B6	B5	B4	B3	B2	B1	B0	DEFAULT
55h	Fan Minimum Drive	128	64	32	16	8	4	2	1	80h

The Fan Minimum Drive Register stores the minimum drive setting for the RPM based Fan Control Algorithm. The RPM based Fan Control Algorithm will not drive the fan at a level lower than the minimum drive unless the target Fan Speed is set at FFh (see [Section 6.18](#)).

During normal operation, if the fan stops for any reason (including low drive), the RPM based Fan Control Algorithm will attempt to restart the fan. Setting the Fan Minimum Drive Registers to a setting that will maintain fan operation is a useful way to avoid potential fan oscillations as the control circuitry attempts to drive it at a level that cannot support fan operation.

The Fan Minimum Drive Register is software locked.

## 6.17 Valid TACH Count Register

**Table 6.24 Valid TACH Count Register**

ADDRESS	REGISTER	LIMIT2K	B7	B6	B5	B4	B3	B2	B1	B0	DEFAULT
56h	Valid TACH Count	'0'	2048	1024	512	256	128	64	32	16	F5h
		'1'	512	256	128	64	32	16	8	4	

The Valid TACH Count Register stores the maximum TACH count to indicate that the fan is spinning properly. The value is referenced at the end of the Spin Up Routine to determine if the fan has started operating and decide if the device needs to retry. See [Equation \[3\]](#) for translating the count to an RPM.

If the TACH count exceeds the Valid TACH Count Register (indicating that the Fan RPM is below the threshold set by this count), then a stalled fan is detected. In this condition, the algorithm will automatically begin its Spin Up Routine.

If a TACH Target Count is set above the Valid TACH Count setting, then that setting will be ignored and the algorithm will use the current fan drive setting.

The Valid TACH Count Register is software locked.

## 6.18 TACH Target Register

**Table 6.25 TACH Reading Registers**

ADDRESS	REGISTER	LIMIT2K	B7	B6	B5	B4	B3	B2	B1	B0	DEFAULT
57h	TACH Target	'0'	2048	1024	512	256	128	64	32	16	FAh
		'1'	512	256	128	64	32	16	8	4	

The TACH Target Register holds the target TACH count that is maintained by the RPM based Fan Control Algorithm.

If the algorithm is enabled, setting the Fan Target to FFh will immediately disable the High Side Fan Driver. Setting the Fan Target to any other value will cause the algorithm to invoke the Spin Up Routine after which it will function normally.

## 6.19 TACH Reading Register

**Table 6.26 TACH Reading Register**

ADDRESS	REGISTER	LIMIT2K	B7	B6	B5	B4	B3	B2	B1	B0	DEFAULT
58h	Fan TACH	'0'	2048	1024	512	256	128	64	32	16	FFh
		'1'	512	256	128	64	32	16	8	4	

The TACH Reading Register contents describe the current TACH setting of the fan. The data represents the fan speed as the number of 32.768kHz clock periods that occur for a single revolution of the fan.

## Datasheet

Equation [3] shows the simplified translation of TACH Reading Register count to RPM assuming a 2-pole fan, measuring 5 edges.

$$RPM = \frac{1}{COUNT}(\text{revolutions}) \times 32768 \left( \frac{1}{\text{sec}} \right) \times 60 \left( \frac{\text{sec}}{\text{min}} \right) \quad \text{COUNT} = \text{TACH Reading Register value (in decimal)} \quad [3]$$

Table 6.27 Example TACH Reading for Specific Fan Speeds

TACH READING REGISTER	LIMIT2K	RPM
F6h	0	500
FFh (Note 6.2)	1	500
3Dh	0	2000
F5h	1	2000
0Fh	0	8000
3Dh	1	8000
07h	0	16000
1Eh	1	16000

**Note 6.2** If the LIMIT2K bit is set, the minimum fan speed that can be measured is approximately 1950RPM. Any fan speed lower than this value will be reported as FFh.

## 6.20 Product ID Register

Table 6.28 Product ID Register

ADDRESS	REGISTER	B7	B6	B5	B4	B3	B2	B1	B0	DEFAULT
FDh	Product ID Register (EMC2102-1)	0	0	0	1	0	1	0	0	14h

The Product ID Register contains a unique 8 bit word that identifies the product.

## 6.21 Revision Register

Table 6.29 Revision Register

ADDRESS	REGISTER	B7	B6	B5	B4	B3	B2	B1	B0	DEFAULT
FFh	Revision	0	0	0	0	0	0	0	0	00h

The Revision Register contains a 8 bit word that identifies the die revision.

## Chapter 7 Package Drawing

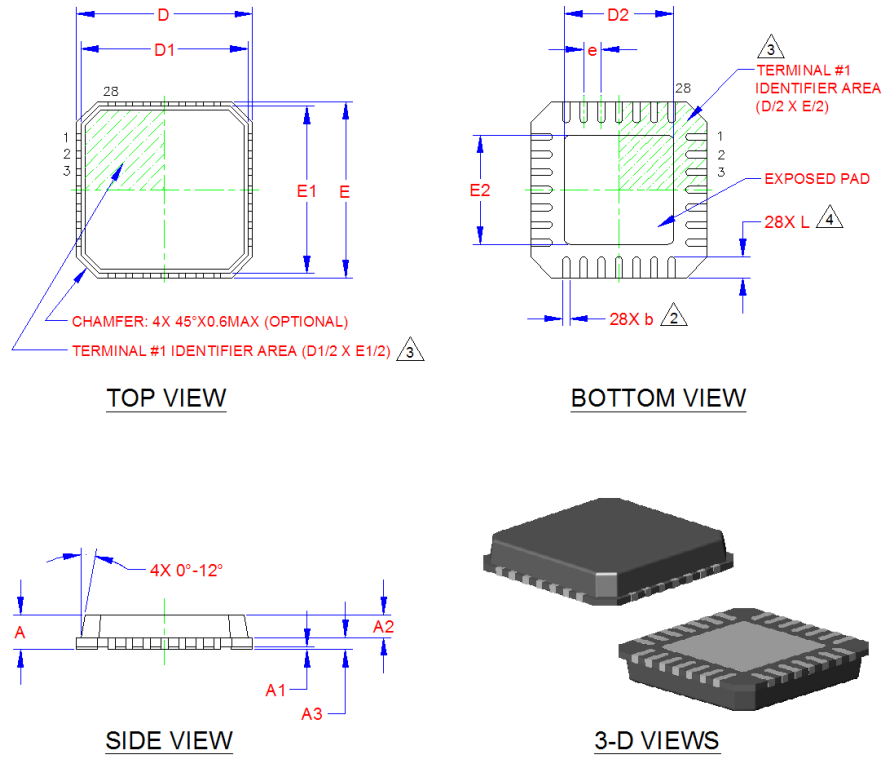

COMMON DIMENSIONS					
SYMBOL	MIN	NOM	MAX	NOTE	REMARK
A	0.80	-	1.00	-	OVERALL PACKAGE HEIGHT
A1	0	0.02	0.05	-	STANDOFF
A2	0.60	-	0.80	-	MOLD CAP THICKNESS
A3	0.20		-	-	LEADFRAME THICKNESS
D/E	4.85	5.00	5.15	-	X/Y BODY SIZE
D1/E1	4.55	-	4.95	-	X/Y MOLD CAP SIZE
D2/E2	SEE VARIATIONS		-	2	X/Y EXPOSED PAD SIZE
L	0.50	-	0.75	4	TERMINAL LENGTH
b	0.18	-	0.30	2	TERMINAL WIDTH
e	0.50 BSC		-	-	TERMINAL PITCH

D2/E2 VARIATIONS				
MIN	NOM	MAX	NOTE	CATALOG PART #
2.95	3.10	3.25	2	EMC2102

**NOTES:**

1. ALL DIMENSIONS ARE IN MILLIMETER.
2. POSITION TOLERANCE OF EACH TERMINAL AND EXPOSED PAD IS  $\pm 0.05\text{mm}$  AT MAXIMUM MATERIAL CONDITION. DIMENSIONS "b" APPLIES TO PLATED TERMINALS AND IT IS MEASURED BETWEEN 0.15 AND 0.30 mm FROM THE TERMINAL TIP.
3. DETAILS OF TERMINAL #1 IDENTIFIER ARE OPTIONAL BUT MUST BE LOCATED WITHIN THE AREA INDICATED.
4. ROUNDED INNER TIPS ON TERMINALS ARE OPTIONAL.

**Figure 7.1 EMC2102 28-Pin 5x5mm QFN Package Outline and Parameters**

## Datasheet

## Appendix A TACH Reading Table - 2000 RPM Range

**Table A.1 TACH Reading  
Table - Limit2K = '1'**

DEC	HEX	RPM
1	1	491520
2	2	245760
3	3	163840
4	4	122880
5	5	98304
6	6	81920
7	7	70217
8	8	61440
9	9	54613
10	A	49152
11	B	44684
12	C	40960
13	D	37809
14	E	35109
15	F	32768
16	10	30720
17	11	28913
18	12	27307
19	13	25869
20	14	24576
21	15	23406
22	16	22342
23	17	21370
24	18	20480
25	19	19661
26	1A	18905
27	1B	18204
28	1C	17554

**Table A.1 TACH Reading  
Table - Limit2K = '1'**

DEC	HEX	RPM
29	1D	16949
30	1E	16384
31	1F	15855
32	20	15360
33	21	14895
34	22	14456
35	23	14043
36	24	13653
37	25	13284
38	26	12935
39	27	12603
40	28	12288
41	29	11988
42	2A	11703
43	2B	11431
44	2C	11171
45	2D	10923
46	2E	10685
47	2F	10458
48	30	10240
49	31	10031
50	32	9830
51	33	9638
52	34	9452
53	35	9274
54	36	9102
55	37	8937
56	38	8777
57	39	8623
58	3A	8474
59	3B	8331
60	3C	8192

**Table A.1 TACH Reading  
Table - Limit2K = '1'**

DEC	HEX	RPM
61	3D	8058
62	3E	7928
63	3F	7802
64	40	7680
65	41	7562
66	42	7447
67	43	7336
68	44	7228
69	45	7123
70	46	7022
71	47	6923
72	48	6827
73	49	6733
74	4A	6642
75	4B	6554
76	4C	6467
77	4D	6383
78	4E	6302
79	4F	6222
80	50	6144
81	51	6068
82	52	5994
83	53	5922
84	54	5851
85	55	5783
86	56	5715
87	57	5650
88	58	5585
89	59	5523
90	5A	5461
91	5B	5401
92	5C	5343

**Table A.1 TACH Reading**  
 Table - Limit2K = '1'

DEC	HEX	RPM
93	5D	5285
94	5E	5229
95	5F	5174
96	60	5120
97	61	5067
98	62	5016
99	63	4965
100	64	4915
101	65	4867
102	66	4819
103	67	4772
104	68	4726
105	69	4681
106	6A	4637
107	6B	4594
108	6C	4551
109	6D	4509
110	6E	4468
111	6F	4428
112	70	4389
113	71	4350
114	72	4312
115	73	4274
116	74	4237
117	75	4201
118	76	4165
119	77	4130
120	78	4096
121	79	4062
122	7A	4029
123	7B	3996
124	7C	3964

**Table A.1 TACH Reading**  
 Table - Limit2K = '1'

DEC	HEX	RPM
125	7D	3932
126	7E	3901
127	7F	3870
128	80	3840
129	81	3810
130	82	3781
131	83	3752
132	84	3724
133	85	3696
134	86	3668
135	87	3641
136	88	3614
137	89	3588
138	8A	3562
139	8B	3536
140	8C	3511
141	8D	3486
142	8E	3461
143	8F	3437
144	90	3413
145	91	3390
146	92	3367
147	93	3344
148	94	3321
149	95	3299
150	96	3277
151	97	3255
152	98	3234
153	99	3213
154	9A	3192
155	9B	3171
156	9C	3151

**Table A.1 TACH Reading**  
 Table - Limit2K = '1'

DEC	HEX	RPM
157	9D	3131
158	9E	3111
159	9F	3091
160	A0	3072
161	A1	3053
162	A2	3034
163	A3	3015
164	A4	2997
165	A5	2979
166	A6	2961
167	A7	2943
168	A8	2926
169	A9	2908
170	AA	2891
171	AB	2874
172	AC	2858
173	AD	2841
174	AE	2825
175	AF	2809
176	B0	2793
177	B1	2777
178	B2	2761
179	B3	2746
180	B4	2731
181	B5	2716
182	B6	2701
183	B7	2686
184	B8	2671
185	B9	2657
186	BA	2643
187	BB	2628
188	BC	2614



## Datasheet

**Table A.1 TACH Reading  
Table - Limit2K = '1'**

DEC	HEX	RPM
189	BD	2601
190	BE	2587
191	BF	2573
192	C0	2560
193	C1	2547
194	C2	2534
195	C3	2521
196	C4	2508
197	C5	2495
198	C6	2482
199	C7	2470
200	C8	2458
201	C9	2445
202	CA	2433
203	CB	2421
204	CC	2409
205	CD	2398
206	CE	2386
207	CF	2374
208	D0	2363
209	D1	2352
210	D2	2341
211	D3	2329
212	D4	2318
213	D5	2308
214	D6	2297
215	D7	2286
216	D8	2276
217	D9	2265
218	DA	2255
219	DB	2244
220	DC	2234

**Table A.1 TACH Reading  
Table - Limit2K = '1'**

DEC	HEX	RPM
221	DD	2224
222	DE	2214
223	DF	2204
224	E0	2194
225	E1	2185
226	E2	2175
227	E3	2165
228	E4	2156
229	E5	2146
230	E6	2137
231	E7	2128
232	E8	2119
233	E9	2110
234	EA	2101
235	EB	2092
236	EC	2083
237	ED	2074
238	EE	2065
239	EF	2057
240	F0	2048
241	F1	2040
242	F2	2031
243	F3	2023
244	F4	2014
245	F5	2006
246	F6	1998
247	F7	1990
248	F8	1982
249	F9	1974
250	FA	1966
251	FB	1958
252	FC	1950

**Table A.1 TACH Reading  
Table - Limit2K = '1'**

DEC	HEX	RPM
253	FD	1943
254	FE	1935
255	FF	Disabled

## Appendix B TACH Reading Table - 500RPM Range

**Table B.1 TACH Reading Table - Limit2K = '0'**

DEC	HEX	RPM
1	1	122880
2	2	61440
3	3	40960
4	4	30720
5	5	24576
6	6	20480
7	7	17554
8	8	15360
9	9	13653
10	A	12288
11	B	11171
12	C	10240
13	D	9452
14	E	8777
15	F	8192
16	10	7680
17	11	7228
18	12	6827
19	13	6467
20	14	6144
21	15	5851
22	16	5585
23	17	5343
24	18	5120
25	19	4915
26	1A	4726
27	1B	4551

**Table B.1 TACH Reading Table - Limit2K = '0'**

DEC	HEX	RPM
28	1C	4389
29	1D	4237
30	1E	4096
31	1F	3964
32	20	3840
33	21	3724
34	22	3614
35	23	3511
36	24	3413
37	25	3321
38	26	3234
39	27	3151
40	28	3072
41	29	2997
42	2A	2926
43	2B	2858
44	2C	2793
45	2D	2731
46	2E	2671
47	2F	2614
48	30	2560
49	31	2508
50	32	2458
51	33	2409
52	34	2363
53	35	2318
54	36	2276
55	37	2234
56	38	2194
57	39	2156
58	3A	2119
59	3B	2083

**Table B.1 TACH Reading Table - Limit2K = '0'**

DEC	HEX	RPM
60	3C	2048
61	3D	2014
62	3E	1982
63	3F	1950
64	40	1920
65	41	1890
66	42	1862
67	43	1834
68	44	1807
69	45	1781
70	46	1755
71	47	1731
72	48	1707
73	49	1683
74	4A	1661
75	4B	1638
76	4C	1617
77	4D	1596
78	4E	1575
79	4F	1555
80	50	1536
81	51	1517
82	52	1499
83	53	1480
84	54	1463
85	55	1446
86	56	1429
87	57	1412
88	58	1396
89	59	1381
90	5A	1365
91	5B	1350

## Datasheet

**Table B.1 TACH Reading**  
Table - Limit2K = '0'

DEC	HEX	RPM
92	5C	1336
93	5D	1321
94	5E	1307
95	5F	1293
96	60	1280
97	61	1267
98	62	1254
99	63	1241
100	64	1229
101	65	1217
102	66	1205
103	67	1193
104	68	1182
105	69	1170
106	6A	1159
107	6B	1148
108	6C	1138
109	6D	1127
110	6E	1117
111	6F	1107
112	70	1097
113	71	1087
114	72	1078
115	73	1069
116	74	1059
117	75	1050
118	76	1041
119	77	1033
120	78	1024
121	79	1016
122	7A	1007
123	7B	999

**Table B.1 TACH Reading**  
Table - Limit2K = '0'

DEC	HEX	RPM
124	7C	991
125	7D	983
126	7E	975
127	7F	968
128	80	960
129	81	953
130	82	945
131	83	938
132	84	931
133	85	924
134	86	917
135	87	910
136	88	904
137	89	897
138	8A	890
139	8B	884
140	8C	878
141	8D	871
142	8E	865
143	8F	859
144	90	853
145	91	847
146	92	842
147	93	836
148	94	830
149	95	825
150	96	819
151	97	814
152	98	808
153	99	803
154	9A	798
155	9B	793

**Table B.1 TACH Reading**  
Table - Limit2K = '0'

DEC	HEX	RPM
156	9C	788
157	9D	783
158	9E	778
159	9F	773
160	A0	768
161	A1	763
162	A2	759
163	A3	754
164	A4	749
165	A5	745
166	A6	740
167	A7	736
168	A8	731
169	A9	727
170	AA	723
171	AB	719
172	AC	714
173	AD	710
174	AE	706
175	AF	702
176	B0	698
177	B1	694
178	B2	690
179	B3	686
180	B4	683
181	B5	679
182	B6	675
183	B7	671
184	B8	668
185	B9	664
186	BA	661
187	BB	657

**Table B.1 TACH Reading**  
 Table - Limit2K = '0'

DEC	HEX	RPM
188	BC	654
189	BD	650
190	BE	647
191	BF	643
192	C0	640
193	C1	637
194	C2	633
195	C3	630
196	C4	627
197	C5	624
198	C6	621
199	C7	617
200	C8	614
201	C9	611
202	CA	608
203	CB	605
204	CC	602
205	CD	599
206	CE	597
207	CF	594
208	D0	591
209	D1	588
210	D2	585
211	D3	582
212	D4	580
213	D5	577
214	D6	574
215	D7	572
216	D8	569
217	D9	566
218	DA	564
219	DB	561

**Table B.1 TACH Reading**  
 Table - Limit2K = '0'

DEC	HEX	RPM
220	DC	559
221	DD	556
222	DE	554
223	DF	551
224	E0	549
225	E1	546
226	E2	544
227	E3	541
228	E4	539
229	E5	537
230	E6	534
231	E7	532
232	E8	530
233	E9	527
234	EA	525
235	EB	523
236	EC	521
237	ED	518
238	EE	516
239	EF	514
240	F0	512
241	F1	510
242	F2	508
243	F3	506
244	F4	504
245	F5	502
246	F6	500
247	F7	497
248	F8	495
249	F9	493
250	FA	492
251	FB	490

**Table B.1 TACH Reading**  
 Table - Limit2K = '0'

DEC	HEX	RPM
252	FC	488
253	FD	486
254	FE	484
255	FF	Disabled