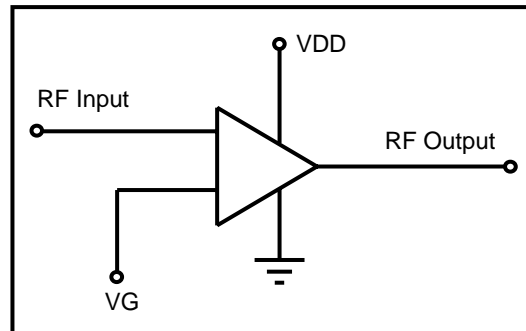

2-20GHZ BROADBAND MMIC AMPLIFIER
FEATURES:

- Cascode Configuration
- 11dB Gain
- pHEMT Technology
- AGC control with gate bias
- Input Return Loss <-15dB
- Output Return Loss <-10dB
- Medium Power 20dBm

GENERAL DESCRIPTION:

The FMA3008 is a high performance 2-20GHz Gallium Arsenide monolithic travelling wave amplifier. It is suitable for use in broadband communication, instrumentation and electronic warfare applications. The die is fabricated using the Filtronic 0.25 μ m process. The cascode gate voltage is supplied on Chip, with the option of supplying an external voltage. The Circuit is DC blocked at both the input and output.

FUNCTIONAL SCHEMATIC:

TYPICAL APPLICATIONS:

- Test Instrumentation
- Electronic Warfare
- Broadband Communication Infrastructure

ELECTRICAL SPECIFICATIONS:

PARAMETER	CONDITIONS	MIN	TYP	MAX	UNITS
Small Signal Gain	2-20GHz		11		dB
Input Return Loss	2-20GHz		-10		dB
Output Return Loss	2-20GHz		-14		dB
Reverse Isolation	2-20GHz		<-40		dB
Output Power at 1dB compression point	10GHz		23.5		dBm
	18GHz		22.5		dBm
Noise Figure	2-20GHz		4.5		dB
Gate Voltage	For Id=120mA		-0.3		V

Note: T_{AMBIENT} = +25°C, Z₀ = 50 Ω , VD=6V

ABSOLUTE MAXIMUM RATINGS:

PARAMETER	SYMBOL	ABSOLUTE MAXIMUM
Max Input Power	Pin	+25dBm
Gate Voltage	VG1	-2V
Drain Voltage	VDD	+10V
Total Power Dissipation	Ptot	tbd
Gain Compression	Comp	tbd
Thermal Resistivity	θ_{JC}	0.66°C/W
Operating Temp	Toper	-40°C to +85°C
Storage Temp	Tstor	-55°C to +150°C

Note: Exceeding any one of these absolute maximum ratings may cause permanent damage to the device.

PAD LAYOUT:

PAD REF	PAD NAME	DESCRIPTION	PIN COORDINATES (μm)
A	RF in	RF in	(105,713)
B	GND	Ground	(198, 126)
C	VG1	Gate Voltage	(461, 128)
D	Out	RF Output	(663, 713)
E	GND	Ground	(2170, 1580)
F	VD	Drain Voltage	(1998, 1580)
G	VG2	Cascode Gate Voltage (Optional)	(132, 1107)

Note: Co-ordinates are referenced from the bottom left hand corner of the die to the centre of bond pad opening

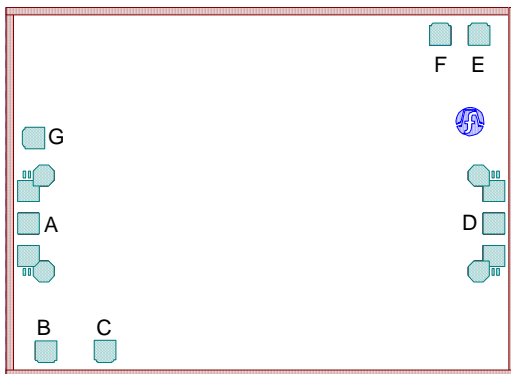

DIE SIZE (μm)	DIE THICKNESS (μm)	MIN. BOND PAD PITCH (μm)	MIN. BOND PAD OPENING ($\mu\text{m} \times \mu\text{m}$)
2350 x 1710	100	179	100 x 100

TYPICAL PERFORMANCE FOR ON WAFER MEASUREMENTS:

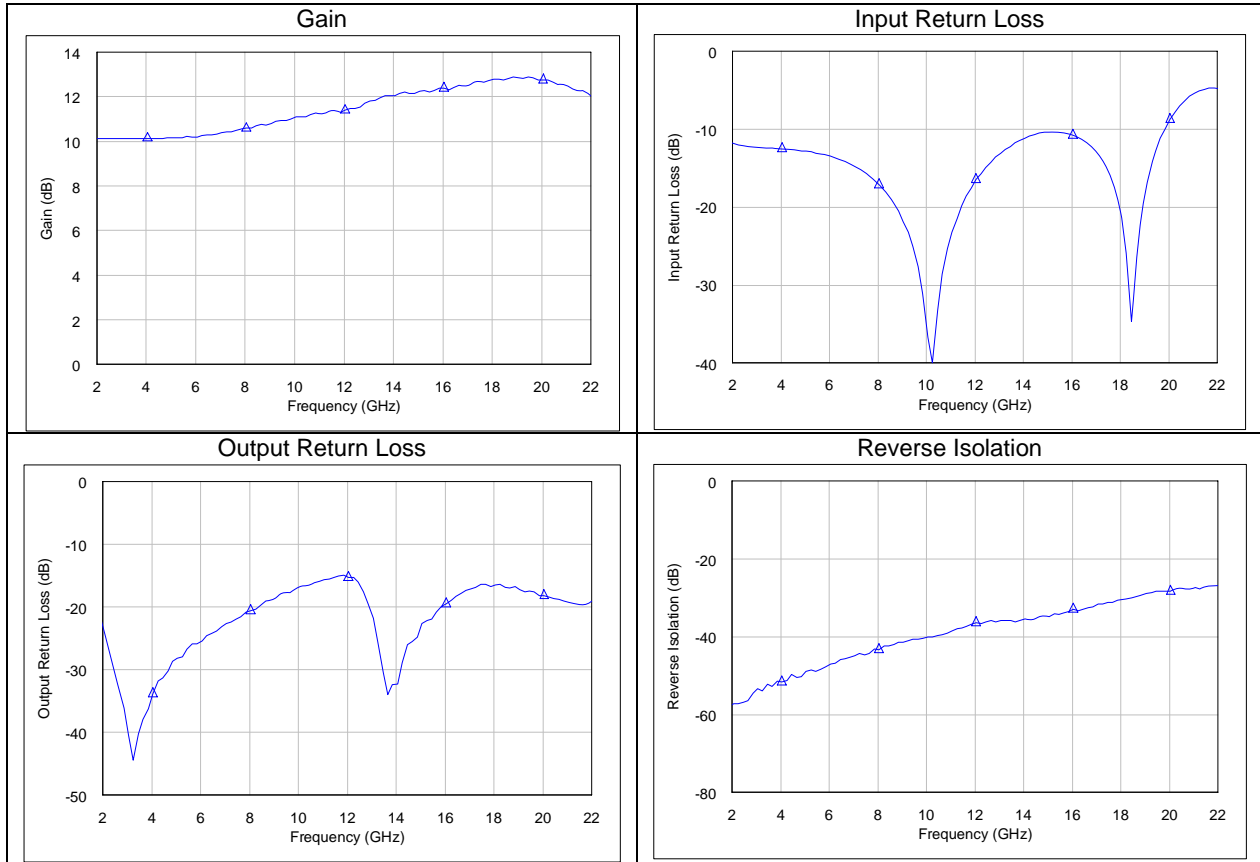
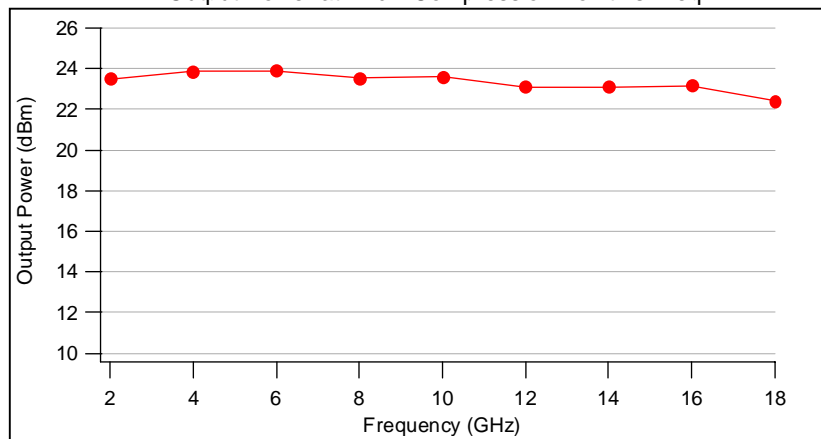
 Note: Measurement Conditions $V_{G1} = -0.3V$, $I_D = 120mA$, $V_{DD} = 6V$, $T_{AMBIENT} = 25^{\circ}C$

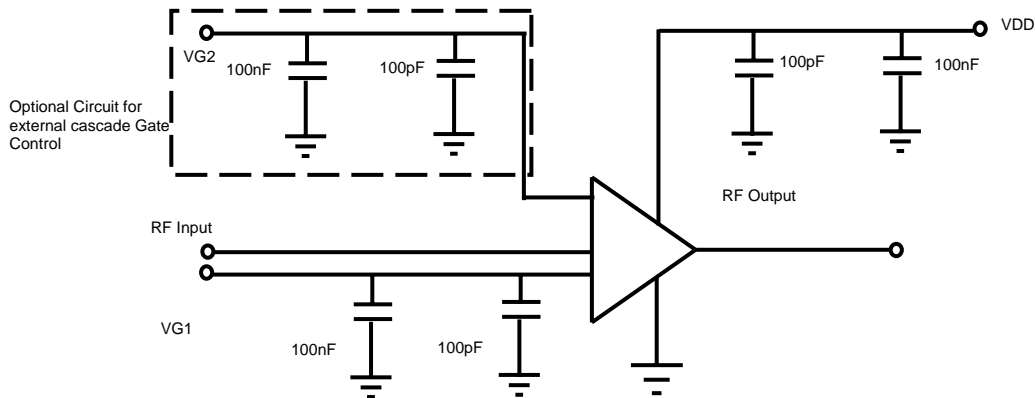
Output Power at P1dB Compression Point vs Freq

BIASING CIRCUIT SCHEMATIC:

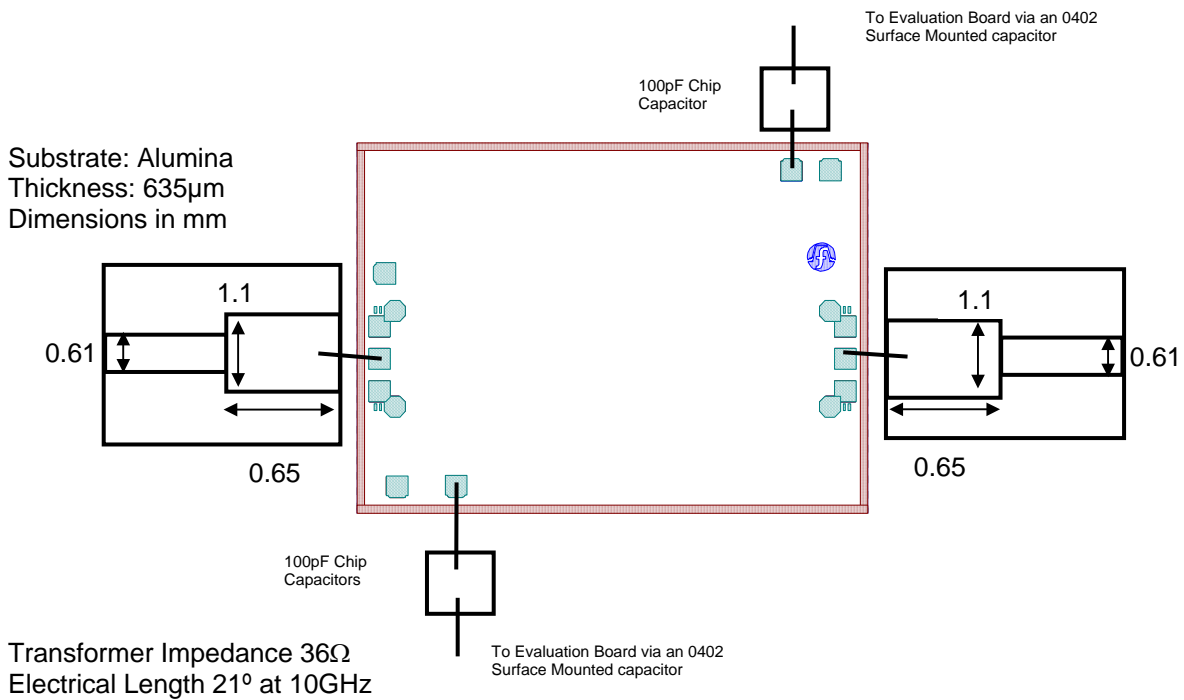
ASSEMBLY DIAGRAM:

It is recommended that the RF connections be made using two bond wires 25 μ m in diameter and a maximum length of 300 μ m. Optimum input and output return loss can be achieved, to compensate for bond wire length, with the addition of a microstrip transformer, shown in the diagram below.

BILL OF MATERIALS:

COMPONENT
All RF tracks should be 50 Ω characteristic material
Capacitor, 100pF, chip capacitor
Capacitor, 100pF, 0402

PREFERRED ASSEMBLY INSTRUCTIONS:

GaAs devices are fragile and should be handled with great care. Specially designed collets should be used where possible.

The recommended die attach is gold/tin eutectic solder under a nitrogen atmosphere. Stage temperature should be 280-290°C; maximum time at temperature is one minute. The recommended wire bond method is thermo-compression wedge bonding with 0.7 or 1.0 mil (0.018 or 0.025 mm) gold wire. Stage temperature should be 250-260°C.

Bonds should be made from the die first and then to the mounting substrate or package. The physical length of the bondwires should be minimised especially when making RF or ground connections.

ORDERING INFORMATION:

PART NUMBER	DESCRIPTION
FMA3008	Die in Waffle-pack (Gel-pak available on request)

HANDLING PRECAUTIONS:

To avoid damage to the devices care should be exercised during handling. Proper Electrostatic Discharge (ESD) precautions should be observed at all stages of storage, handling, assembly, and testing. These devices should be treated as Class 1A (0-500 V) as defined in JEDEC Standard No. 22-A114. Further information on ESD control measures can be found in MIL-STD-1686 and MIL-HDBK-263.

APPLICATION NOTES & DESIGN DATA:

Application Notes and design data including S-parameters, noise data and large-signal models are available on request.

DISCLAIMERS:

This product is not designed for use in any space based or life sustaining/supporting equipment.