

FEATURES

- Dual Device Module
- Electrically Isolated Package
- Pressure Contact Construction
- International Standard Footprint
- Alumina (non-toxic) Isolation Medium

APPLICATIONS

- Rectifier Bridges
- DC Power Bridges
- Plating Rectifiers
- Traction Systems

VOLTAGE RATINGS

Type Number	Repetitive Peak Voltages V_{RRM}	Conditions
MP02/260-16	1600	$T_{vj} = 150^{\circ}\text{C}$ $I_{RM} = 30\text{mA}$ $V_{RSM} = V_{RRM} + 100\text{V}$
MP02/260-14	1400	
MP02/260-12	1200	
MP02/260-10	1000	

Lower voltage grades available. For full description of part numbers see "Ordering instructions" on page 3.

KEY PARAMETERS

V_{RRM}	1600V
I_{FSM}	8100A
$I_{F(AV)}$ (per arm)	267A
V_{isol}	2500V

CIRCUIT OPTIONS

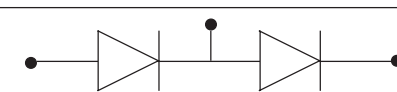
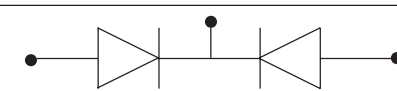
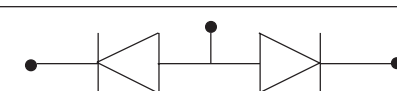
Code	Circuit
HB	
G	
GN	

PACKAGE OUTLINE

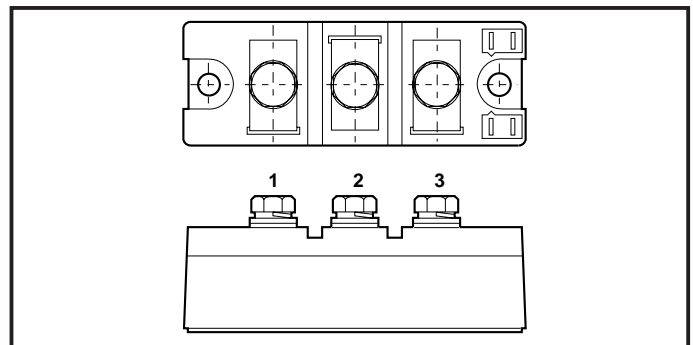

Module outline type code: MP02.
See Package Details for further information.

CURRENT RATINGS - PER ARM

Symbol	Parameter	Conditions	Max.	Units	
$I_{F(AV)}$	Mean forward current	Halfwave, resistive load	$T_{case} = 75^{\circ}\text{C}$	267	A
			$T_{case} = 85^{\circ}\text{C}$	240	A
			$T_{heatsink} = 75^{\circ}\text{C}$	216	A
			$T_{heatsink} = 85^{\circ}\text{C}$	192	A
$I_{F(RMS)}$	RMS value	$T_{case} = 75^{\circ}\text{C}$	420	A	

MP02 XX 260 Series

SURGE RATINGS - PER ARM

Symbol	Parameter	Conditions	Max.	Units	
I_{FSM}	Surge (non-repetitive) forward current	10ms half sine; $T_j = 150^\circ\text{C}$	$V_R = 0$	8100	A
			$V_R = 50\% V_{RRM}$	6500	A
I^2t	I^2t for fusing	10ms half sine; $T_j = 150^\circ\text{C}$	$V_R = 0$	328000	A^2s
			$V_R = 50\% V_{RRM}$	211000	A^2s

THERMAL & MECHANICAL RATINGS

Symbol	Parameter	Conditions	Max.	Units
$R_{th(j-c)}$	Thermal resistance - junction to case per Diode	dc	0.21	$^\circ\text{C}/\text{W}$
		halfwave	0.22	$^\circ\text{C}/\text{W}$
		3 phase	0.23	$^\circ\text{C}/\text{W}$
$R_{th(c-hs)}$	Thermal resistance - case to heatsink per Diode	Mounting torque = 6Nm with mounting compound	0.07	$^\circ\text{C}/\text{W}$
T_{vj}	Virtual junction temperature		150	$^\circ\text{C}$
T_{sto}	Storage temperature range		-40 to 150	$^\circ\text{C}$
V_{isol}	Isolation voltage	Commoned terminals to base plate AC RMS, 1min, 50Hz	2.5	kV

CHARACTERISTICS

Symbol	Parameter	Conditions	Max.	Units
V_{FM}	Forward voltage	At 600A, $T_{case} = 25^\circ\text{C}$	1.3	V
I_{RM}	Peak reverse current	At V_{RRM} , $T_j = 150^\circ\text{C}$	30	mA
V_{TO}	Threshold voltage	At $T_{vj} = 150^\circ\text{C}$	0.84	V
r_T	On-state slope resistance	At $T_{vj} = 150^\circ\text{C}$	0.667	$\text{m}\Omega$

ORDERING INSTRUCTIONS

Part number is made up as follows:

MP02 HB 260 - 12

MP = Pressure contact module
02 = Outline type
HB = Circuit configuration code (see "circuit options" - front page)
260 = Nominal average current rating at $T_{case} = 75^{\circ}C$
12 = $V_{RRM}/100$

Examples:

MP02 HB260-12
MP02 G260-16
MP02 GN260-10

Note: Preferred type is HB configuration. G & GN types are available for specific applications, only when requested.

MOUNTING RECOMMENDATIONS

- Adequate heatsinking is required to maintain the base temperature at $75^{\circ}C$ if full rated current is to be achieved. Power dissipation may be calculated by use of V_{TO} and r_T information in accordance with standard formulae. We can provide assistance with calculations or choice of heatsink if required.
- The heatsink surface must be smooth and flat; a surface finish of N6 (32 μ in) and a flatness within 0.05mm (0.002") are recommended.
- Immediately prior to mounting, the heatsink surface should be lightly scrubbed with fine emery, Scotch Brite or a mild chemical etchant and then cleaned with a solvent to remove oxide build up and foreign material. Care should be taken to ensure no foreign particles remain.
- An even coating of thermal compound (eg. Unial) should be applied to both the heatsink and module mounting surfaces. This should ideally be 0.05mm (0.002") per surface to ensure optimum thermal performance.
- After application of thermal compound, place the module squarely over the mounting holes, (or 'T' slots) in the heatsink. Using a torque wrench, slowly tighten the recommended fixing bolts at each end, rotating each in turn no more than 1/4 of a revolution at a time. Continue until the required torque of 6Nm (55lb.ins) is reached at both ends.
- It is not acceptable to fully tighten one fixing bolt before starting to tighten the others. Such action may DAMAGE the module.

CURVES

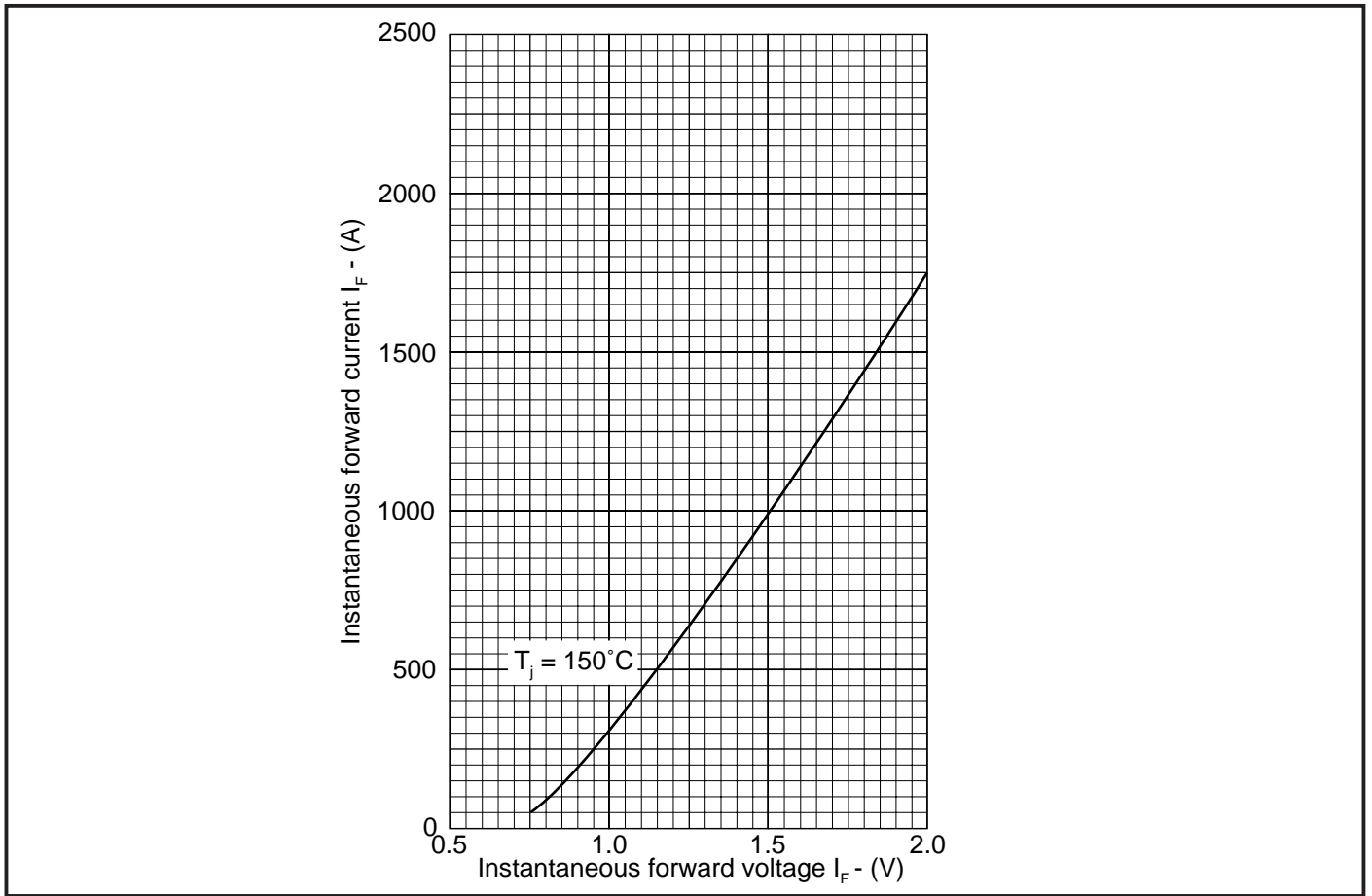

Fig. 1 Maximum (limit) forward characteristics (Per diode)

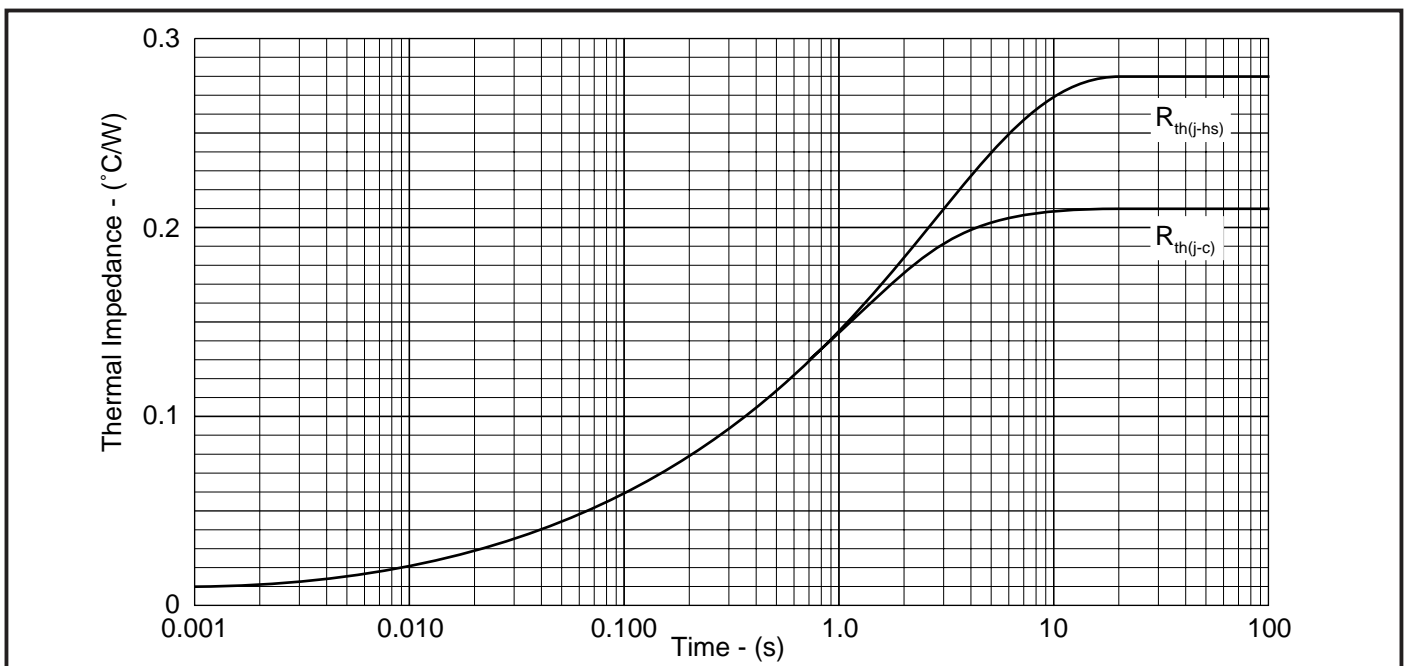

Fig. 2 Transient thermal impedance (DC) - (Per diode)

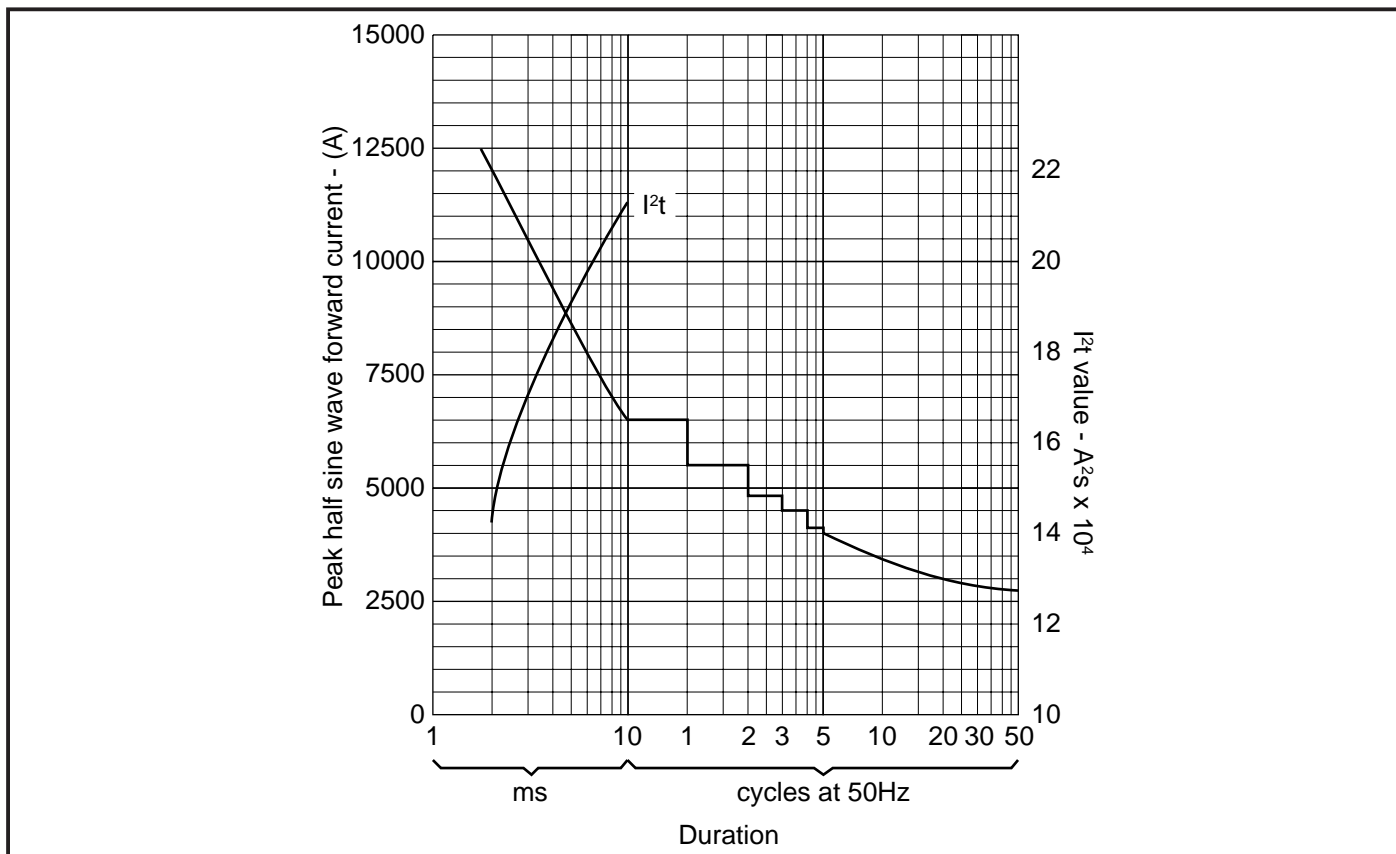

Fig. 3 Surge (non-repetitive) forward current vs time (with 0% V_{RRM} , $T_{case} = 150^\circ C$)

MP02 XX 260 Series

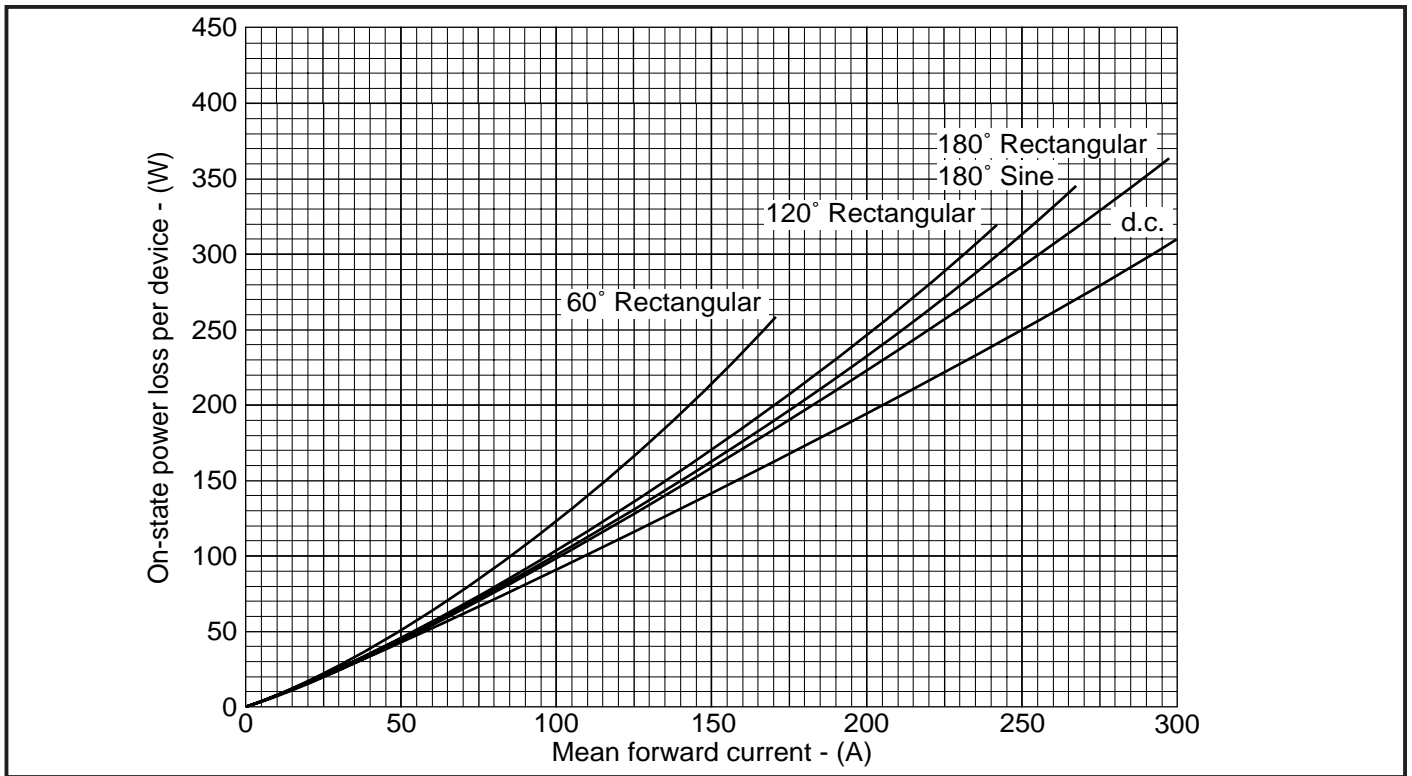

Fig. 4 On-state power loss per arm vs forward current at various conduction angles, 50/60Hz

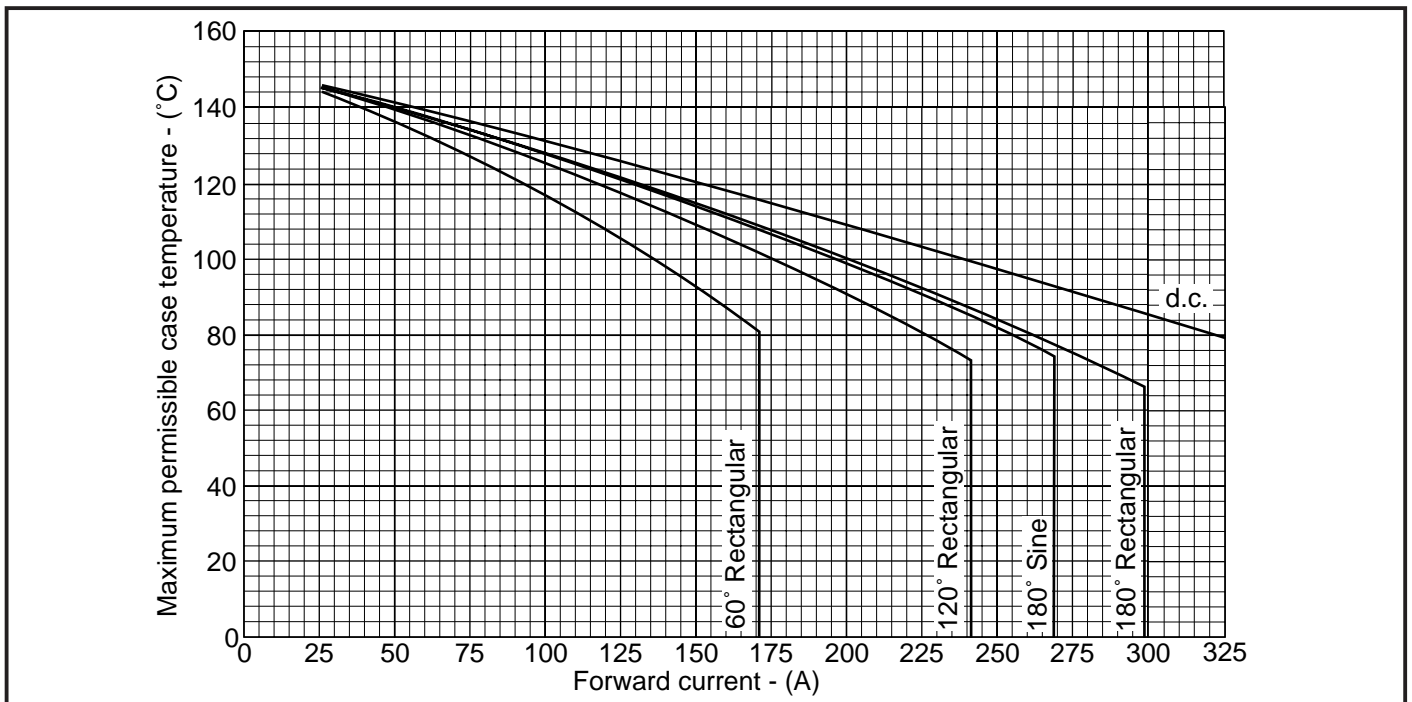

Fig. 5 Maximum permissible case temperature vs forward current per arm at various conduction angles, 50/60Hz

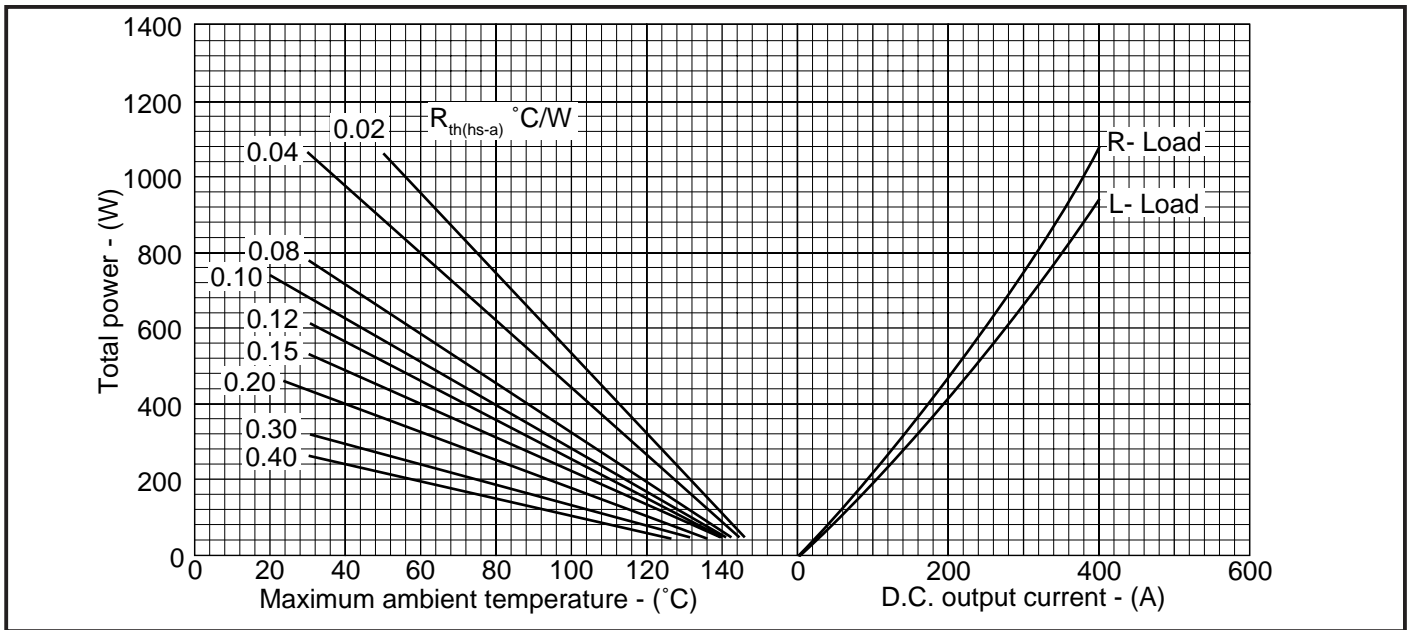

Fig. 6 50/60Hz single phase bridge dc output current vs power loss and maximum permissible ambient temperature for various values of heatsink thermal resistance.

(Note: $R_{th(hs-a)}$ values given above are true heatsink thermal resistances to ambient and already account for $R_{th(c-hs)}$ module contact thermal).

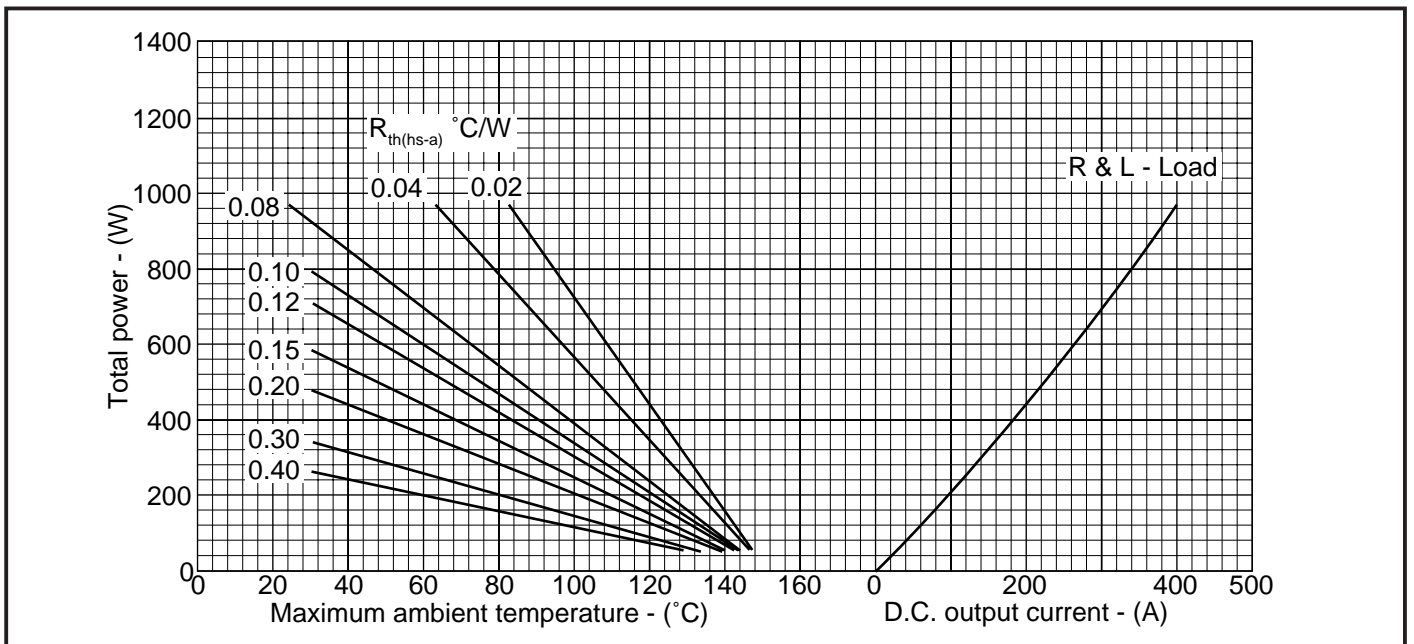

Fig. 7 50/60Hz 3- phase bridge dc output current vs power loss and maximum permissible ambient temperature for various values of heatsink thermal resistance.

(Note: $R_{th(hs-a)}$ values given above are true heatsink thermal resistances to ambient and already account for $R_{th(c-hs)}$ module contact thermal).

MP02 XX 260 Series

PACKAGE DETAILS

For further package information, please contact your local Customer Service Centre. All dimensions in mm, unless stated otherwise. DO NOT SCALE.

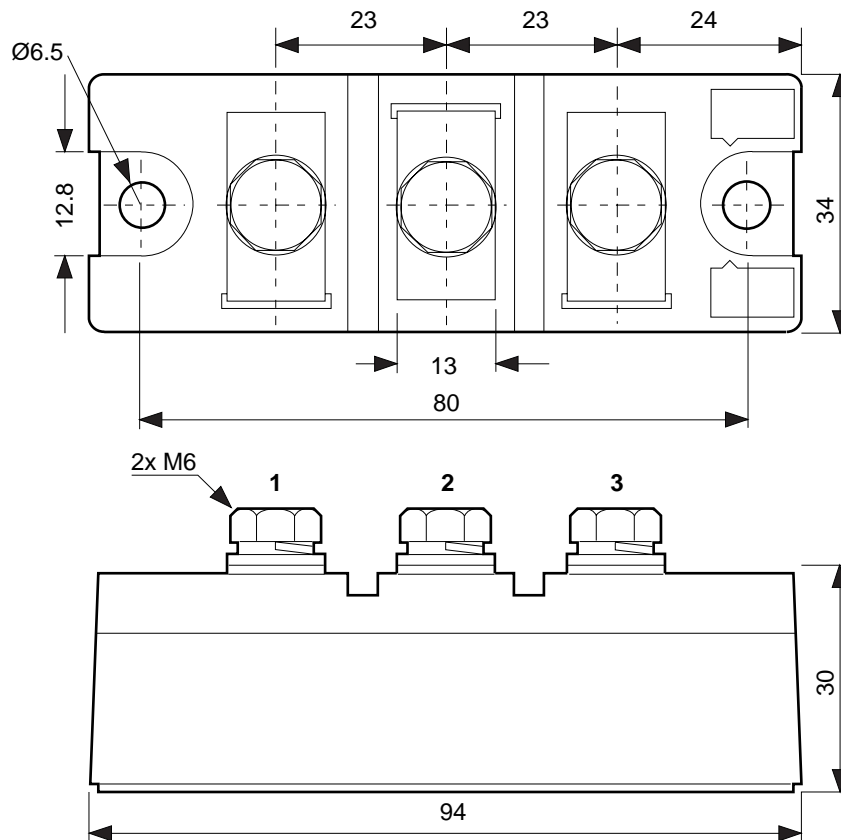

Nominal weight: 350g
Recommended fixings for mounting: M6 socket head cap screws
Recommended mounting torque: 6Nm (55lb.ins)
Recommended torque for electrical connections: 5Nm (44lb.ins)
Maximum torque for electrical connections: 8Nm (70lb.ins)

Module outline type code: MP02

CIRCUIT CONFIGURATIONS

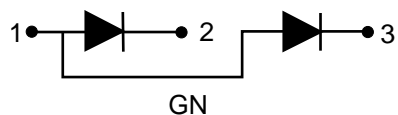
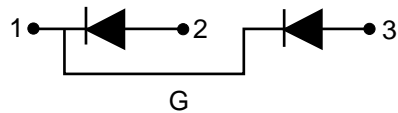
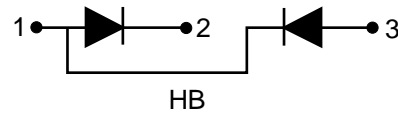



<http://www.dynexsemi.com>

e-mail: power_solutions@dynexsemi.com

HEADQUARTERS OPERATIONS
DYNEX SEMICONDUCTOR LTD
Doddington Road, Lincoln.
Lincolnshire. LN6 3LF. United Kingdom.
Tel: 00-44-(0)1522-500500
Fax: 00-44-(0)1522-500550

DYNEX POWER INC.
Unit 7 - 58 Antares Drive,
Nepean, Ontario, Canada K2E 7W6.
Tel: 613.723.7035
Fax: 613.723.1518
Toll Free: 1.888.33.DYNEX (39639)

CUSTOMER SERVICE CENTRES

France, Benelux, Italy and Spain Tel: +33 (0)1 69 18 90 00. Fax: +33 (0)1 64 46 54 50
North America Tel: 011-800-5554-5554. Fax: 011-800-5444-5444
UK, Germany, Scandinavia & Rest Of World Tel: +44 (0)1522 500500. Fax: +44 (0)1522 500020

SALES OFFICES

France, Benelux, Italy and Spain Tel: +33 (0)1 69 18 90 00. Fax: +33 (0)1 64 46 54 50
Germany Tel: 07351 827723
North America Tel: (613) 723-7035. Fax: (613) 723-1518. Toll Free: 1.888.33.DYNEX (39639) /
Tel: (831) 440-1988. Fax: (831) 440-1989 / Tel: (949) 733-3005. Fax: (949) 733-2986.
UK, Germany, Scandinavia & Rest Of World Tel: +44 (0)1522 500500. Fax: +44 (0)1522 500020

These offices are supported by Representatives and Distributors in many countries world-wide.
© Dynex Semiconductor 2000 Publication No. DS5102-4 Issue No. 4.0 January 2000
TECHNICAL DOCUMENTATION – NOT FOR RESALE. PRINTED IN UNITED KINGDOM

Datasheet Annotations:

Dynex Semiconductor annotate datasheets in the top right hand corner of the front page, to indicate product status. The annotations are as follows:-

Target Information: This is the most tentative form of information and represents a very preliminary specification. No actual design work on the product has been started.

Preliminary Information: The product is in design and development. The datasheet represents the product as it is understood but details may change.

Advance Information: The product design is complete and final characterisation for volume production is well in hand.

No Annotation: The product parameters are fixed and the product is available to datasheet specification.

This publication is issued to provide information only which (unless agreed by the Company in writing) may not be used, applied or reproduced for any purpose nor form part of any order or contract nor to be regarded as a representation relating to the products or services concerned. No warranty or guarantee express or implied is made regarding the capability, performance or suitability of any product or service. The Company reserves the right to alter without prior notice the specification, design or price of any product or service. Information concerning possible methods of use is provided as a guide only and does not constitute any guarantee that such methods of use will be satisfactory in a specific piece of equipment. It is the user's responsibility to fully determine the performance and suitability of any equipment using such information and to ensure that any publication or data used is up to date and has not been superseded. These products are not suitable for use in any medical products whose failure to perform may result in significant injury or death to the user. All products and materials are sold and services provided subject to the Company's conditions of sale, which are available on request.

All brand names and product names used in this publication are trademarks, registered trademarks or trade names of their respective owners.