

MRF557
MRF557G

* G Denotes RoHS Compliant, Pb Free Terminal Finish

**RF & MICROWAVE DISCRETE
LOW POWER TRANSISTORS**

Features

- Specified @ 12.5 V, 870 MHz Characteristics
- Output Power = 1.5 W
- Minimum Gain = 8 dB
- Efficiency 60% (Typ)
- Cost Effective PowerMacro Package
- Electroless Tin Plated Leads for Improved Solderability

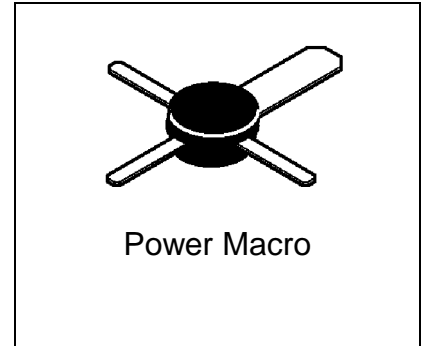

DESCRIPTION: Designed primarily for wideband large signal stages in the UHF frequency range.

ABSOLUTE MAXIMUM RATINGS (Tcase = 25°C)

Symbol	Parameter	Value	Unit
V _{CEO}	Collector-Emitter Voltage	16	Vdc
V _{CBO}	Collector-Base Voltage	30	Vdc
V _{EBO}	Emitter-Base Voltage	3.0	Vdc
I _C	Collector Current	500	mA

Thermal Data

P _D	Total Device Dissipation @ TC = 75°C Derate above 75°C	3.0 40	Watts mW/ °C
----------------	---	-----------	-----------------

ELECTRICAL SPECIFICATIONS (T_{case} = 25°C)

STATIC

Symbol	Test Conditions	Value			Unit
		Min.	Typ.	Max.	
BV _{CEO}	Collector-Emitter Breakdown Voltage (I _C = 5 mAdc, I _B = 0)	16	-	-	Vdc
BV _{CES}	Collector-Emitter Sustaining Voltage (I _C = 5.0 mAdc, I _B = 0)	30	-	-	Vdc
BV _{EBO}	Emitter-Base Breakdown Voltage (I _E = 0.1 mAdc, I _C = 0)	3.0	-	-	Vdc
I _{CES}	Collector Cutoff Current (V _{CE} = 15 Vdc, V _{BE} = 0 Vdc)	-	-	5	mA
HFE	DC Current Gain (I _C = 100 mA, V _{CE} = 5.0 Vdc) Both	50	-	200	-

DYNAMIC

Symbol	Test Conditions	Value			Unit
		Min.	Typ.	Max.	
C _{OB}	Output Capacitance (V _{CB} = 10 Vdc, I _E = 0, f = 1.0 MHz)	-	---	5.5	pF

MRF557

MRF557G

FUNCTIONAL

Symbol	Test Conditions		Value			Unit
			Min.	Typ.	Max.	
G_{PE}	Power Gain	Test Circuit-Figure 1 Pout = 1.5 W, VCE =12.5Vdc f = 870 MHz	8	9	-	dB
η	Collector Efficiency	Test Circuit-Figure 1 Pout = 1.5 W, VCE =12.5Vdc f = 870 MHz	55	60	-	%
Ψ	Load Mismatch VSWR \geq 10:1 All Phase Angles	Test Circuit-Figure 1 Pout = 1.5 W, VCE =12.5Vdc f = 870 MHz	No Degradation in Output Power			-

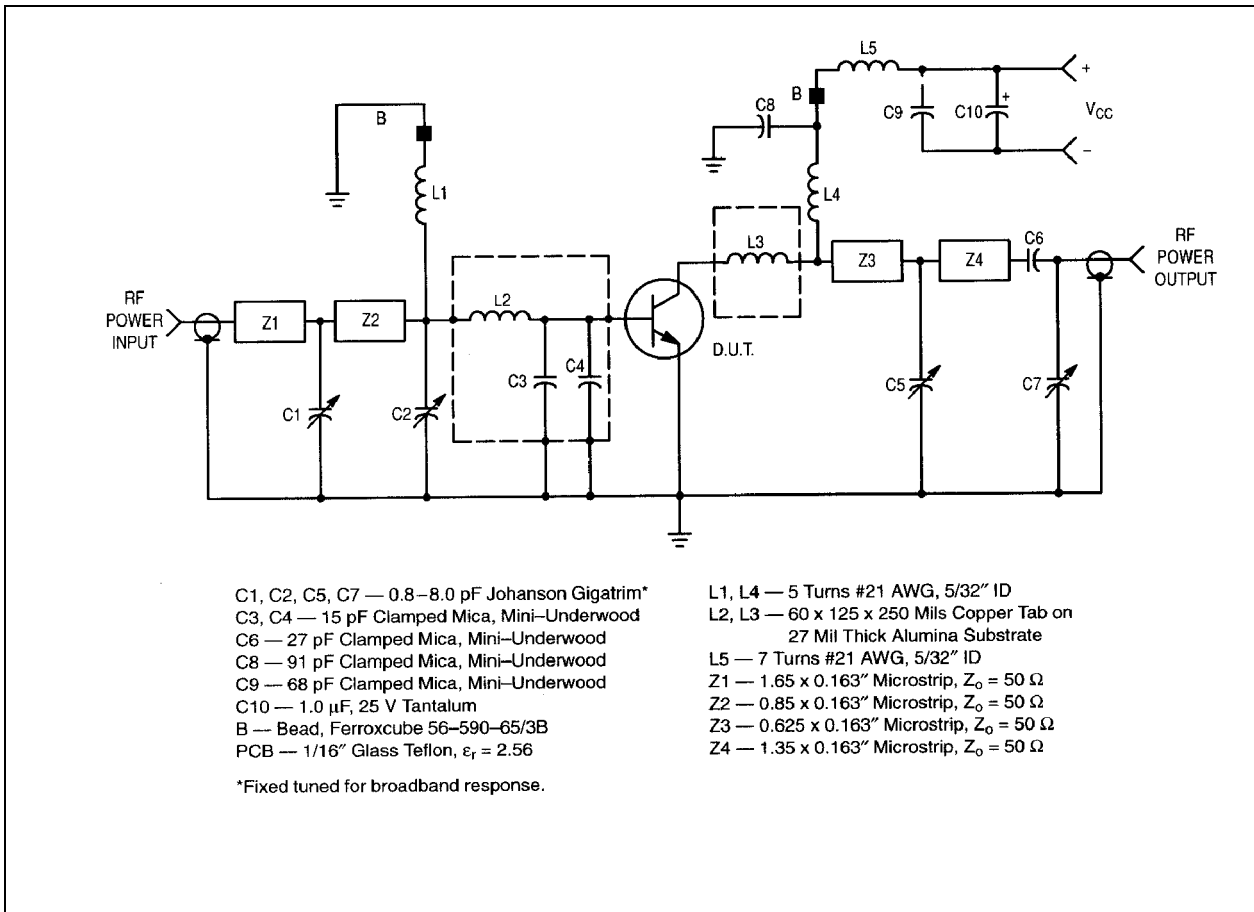

MRF557 MRF557G

RF Low Power PA, LNA, and General Purpose Discrete Selector Guide

Package	Device	Type	GPE Freq (MHz)	Pout (watts)	GPE (dB)	Efficiency (%)	GPE VCC	BVCEO	IC max (mA)
SO-8	MRF4427, R2	NPN	175	0.15	18	60	12	20	400
TO-39	2N4427	NPN	175	1	10	50	12	20	400
POWER MACRO	MRF553	NPN	175	1.5	11.5	60	12.5	16	500
POWER MACRO	MRF553T	NPN	175	1.5	11.5	50	12.5	16	500
TO-39	MRF607	NPN	175	1.75	11.5	50	12.5	16	330
TO-39	2N6255	NPN	175	3	7.8	50	12.5	18	1000
TO-72	2N5179	NPN	200		20	6	12	50	
MACRO X	MRF559	NPN	512	0.5	10	65	7.5	16	150
MACRO X	MRF559	NPN	512	0.5	13	60	12.5	16	150
TO-39	2N3866A	NPN	400	1	10	45	28	30	400
SO-8	MRF3866, R1, R2	NPN	400	1	10	45	28	30	400
POWER MACRO	MRF555	NPN	470	1.5	11	50	12.5	16	400
POWER MACRO	MRF555T	NPN	470	1.5	11	50	12.5	16	400
MACRO X	MRF559	NPN	870	0.5	6.5	70	7.5	16	150
MACRO X	MRF559	NPN	870	0.5	9.5	65	12.5	16	150
SO-8	MRF8372,R1,R2	NPN	870	0.75	8	55	12.5	16	200
POWER MACRO	MRF557	NPN	870	1.5	8	55	12.5	16	400
POWER MACRO	MRF557T	NPN	870	1.5	8	55	12.5	16	400

Package	Device	Type	Freq (MHz)	NF (dB)	NF IC (mA)	NF VCE	GN (dB)	Gu Max (dB)	Ftau (MHz)	Ccb(pF)	BVCEO	IC max (mA)
TO-39	2N5109	NPN	200	3	10	15		12	1200	3.5	20	400
TO-39	MRF5943C	NPN	200	3.4	30	15		11.4	1000		30	400
SO-8	MRF5943, R1, R2	NPN	200	3.4	30	15		15	1300		30	400
TO-72	2N5179	NPN	200	4.5	1.5	6		17	900	1	12	50
TO-72	2N2857	NPN	300	5.5	50	6		13	1600	1	15	40
TO-39	MRF517	NPN	300	7.5	50	15		5.5	4600	3	25	150
TO-72	MRF904	NPN	450	1.5	5	6		11	4000	1	15	30
TO-72	2N6304	NPN	450	5	2	5		14	1400	1	15	50
MACRO T	BFR91	NPN	500	1.9	2	5	11	16.5	5000	1	12	35
MACRO T	BFR96	NPN	500	2	10	10		14.5	500	2.6	15	100
SO-8	MRF5812, R1, R2	NPN	500	2	50	10	15.5	17.8	5000		15	200
MACRO X	MRF581A	NPN	500	2	50	10	14	15	5000		15	200
Macro	BFR90	NPN	500	2.4	2	10	15	18	5000	1	15	30
TO-72	BFY90	NPN	500	2.5	2	5		20	1300		15	50
TO-72	MRF914	NPN	500	2.5	5	10		15	4500		12	40
MACRO X	MRF581	NPN	500	2.5	50	10	15	17.8	5000		16	200
TO-39	MRF586	NPN	500	3	90	15	11	14.5	4500	2.2	17	200
MACRO X	MRF951	NPN	1000	1.3	5	6	14	17	8000	0.45	10	100
MACRO X	MRF571	NPN	1000	1.5	10	6	10		8000	1	10	70
MACRO T	BFR91	NPN	1000	2.5	2	5	8	11	5000	1	12	35
MACRO T	BFR90	NPN	1000	3	2	10	10	12.5	5000	1	15	30
TO-39	MRF545	PNP						14	1400	2	70	400
TO-39	MRF544	NPN						13.5	1500		70	400

RF (Low Power PA / General Purpose) Selection Guide

RF (LNA / General Purpose) Selection Guide

Low Cost RF Plastic Package Options

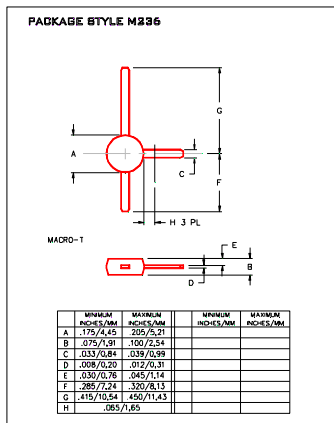

Macro T

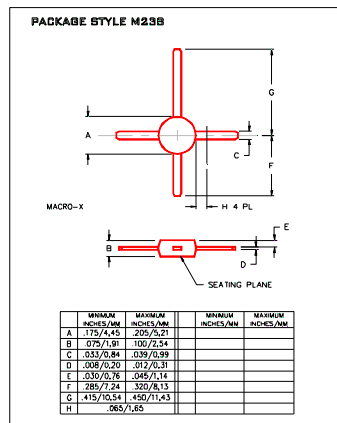

Macro X

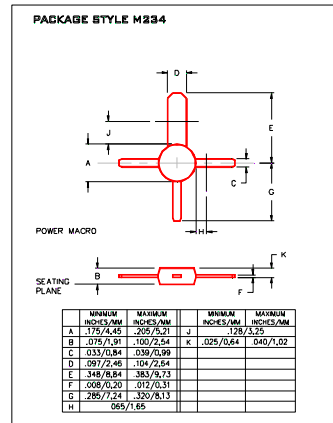

Power Macro

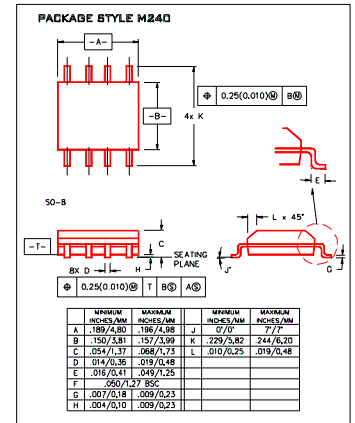

SO-8

**MRF557
MRF557G**

PACKAGE MECHANICAL DATA

PACKAGE STYLE M234

PIN 1. COLLECTOR
2. EMITTER
3. BASE
4. EMITTER

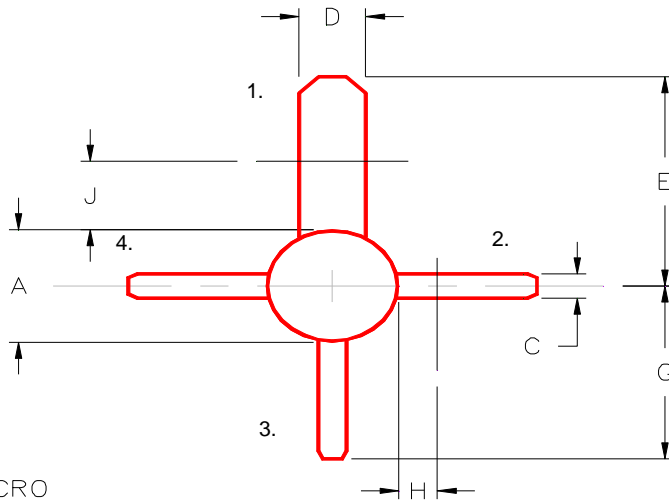

POWER MACRO

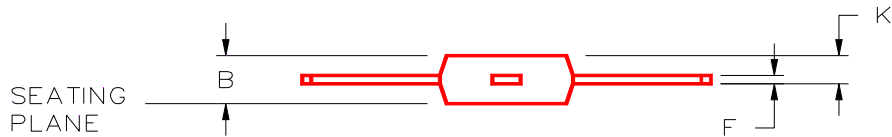

	MINIMUM INCHES/MM	MAXIMUM INCHES/MM		MINIMUM INCHES/MM	MAXIMUM INCHES/MM
A	.175/4,45	.205/5,21	J	.128/3,25	
B	.075/1,91	.100/2,54	K	.025/0,64	.040/1,02
C	.033/0,84	.039/0,99			
D	.097/2,46	.104/2,64			
E	.348/8,84	.383/9,73			
F	.008/0,20	.012/0,31			
G	.285/7,24	.320/8,13			
H	.065/1,65				