



M.S.KENNEDY CORP.

# WIDE BANDWIDTH HIGH VOLTAGE AMPLIFIER

# 601

4707 Dey Road Liverpool, N.Y. 13088

(315) 701-6751

**FEATURES:**

- Ultra Low Quiescent Current -  $\pm 15\text{mA}$  for High Voltage
- 220V Peak to Peak Output Voltage Swing
- Slew Rate -  $3000\text{V}/\mu\text{S}$  Typical
- Gain Bandwidth Product - 200 MHz Typical
- Full Power Output Frequency - 1 MHz Typical
- Output Current - 100mA Peak
- Adjustable V<sub>HV</sub> Power Supplies Minimizes Power Dissipation
- Compact Package Offers Superior Power Dissipation

**MIL-PRF-38534 QUALIFIED**

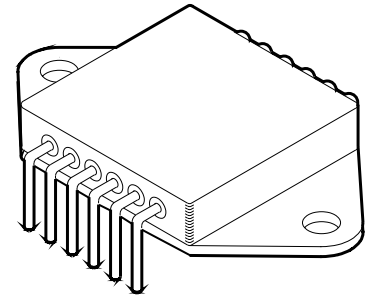

**DESCRIPTION:**

The MSK 601(B) is a high voltage wideband amplifier designed to provide very large voltage swings at high slew rates in wideband systems. The true inverting op-amp topology employed in the MSK 601 provides excellent D.C. specifications such as input offset voltage and input bias current. These attributes are important in amplifiers that will be used in high gain configurations since the input error voltages will be multiplied by the system gain. The MSK 601 achieves impressive slew rate specifications by employing a feed forward A.C. path through the amplifier; however, the device is internally configured in inverting mode to utilize this benefit. Internal compensation for gains of  $-5\text{V}/\text{V}$  or greater keeps the MSK 601 stable in this range. The MSK 601 is packaged in a space efficient, hermetically sealed, 12 pin power dual in line package that has a high thermal conductivity for efficient device cooling.

**EQUIVALENT SCHEMATIC**

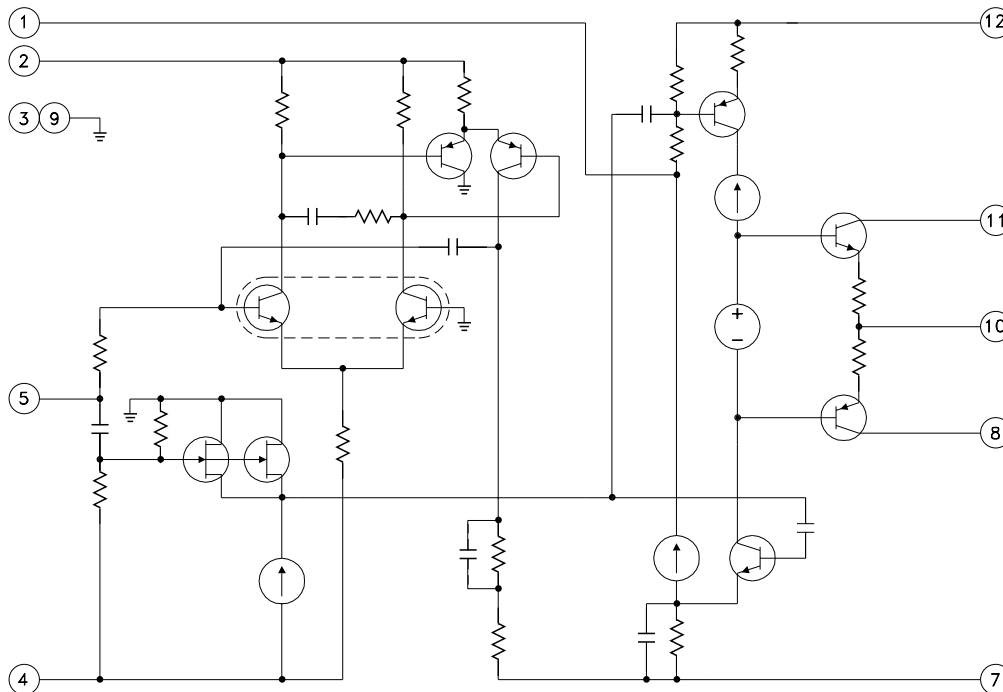

**TYPICAL APPLICATIONS**

- Wideband Very High Voltage Amplifier
- High Resolution CRT Monitor
- Ultra High Performance Video Processing
- CRT Beam Intensity Control
- Varactor Tuned VCO Driver
- Automatic Test Equipment

**PIN-OUT INFORMATION**

1	COMP	12	+VHV
2	+VCC	11	+VSC
3	GROUND	10	OUTPUT
4	-VCC	9	CASE/GROUND
5	-INPUT	8	-VSC
6	NO CONNECTION	7	-VHV

## ABSOLUTE MAXIMUM RATINGS

$\pm V_{HV}$	Supply Voltage . . . . .	$\pm 150V_{DC}$	$T_{ST}$	Storage Temperature Range	$-65^{\circ}C$ to $+150^{\circ}C$
$\pm V_{IN}$	Input Voltage Range. . . . .	$\pm V_{CC}$	$T_{LD}$	Lead Temperature Range . . . . .	$300^{\circ}C$ (10 Seconds)
$\pm V_{CC}$	Supply Voltage (Input Stage). . . . .	$\pm 18V_{DC}$	$T_C$	Case Operating Temperature	MSK601 . . . . . $-40^{\circ}C$ to $+85^{\circ}C$ MSK601B . . . . . $-55^{\circ}C$ to $+125^{\circ}C$
$\theta_{JC}$	Thermal Resistance . . . . .	$18^{\circ}C/W$ (Output Devices)	$T_J$	Junction Temperature. . . . .	$150^{\circ}C$

## ELECTRICAL SPECIFICATIONS

Parameter	Test Conditions ①	Group A Subgroup	MSK 601B			MSK 601			Units
			Min.	Typ.	Max.	Min.	Typ.	Max.	
<b>STATIC</b>									
Quiescent Current	$V_{IN}=0$ @ $+V_{CC}$	1,2,3	-	1.5	2.0	-	1.8	2.5	mA
	$V_{IN}=0$ @ $-V_{CC}$	1,2,3	-	15	25	-	20	30	mA
	$V_{IN}=0$ @ $+V_{HV}$	1,2,3	-	20	30	-	25	35	mA
	$V_{IN}=0$ @ $-V_{HV}$	1,2,3	-	20	30	-	25	35	mA
Input Offset Voltage	$V_{IN}=0$	1	-	$\pm 1.0$	$\pm 5.0$	-	$\pm 1.0$	$\pm 10$	mV
		2,3	-	$\pm 2.0$	$\pm 10.0$	-	$\pm 2.0$	-	mV
Input Bias Current		1	-	50	250	-	50	500	nA
		2,3	-	100	350	-	100	-	nA
Input Offset Voltage Drift ②	$V_{IN}=0$	2,3	-	$\pm 10$	$\pm 50$	-	$\pm 10$	-	$\mu V/^{\circ}C$
Power Supply Range	$\pm V_{CC}$	-	$\pm 12$	$\pm 15$	$\pm 18$	$\pm 12$	$\pm 15$	$\pm 18$	V
	$\pm V_{HV}$	-	$\pm 50$	$\pm 120$	$\pm 150$	$\pm 50$	$\pm 120$	$\pm 150$	V
<b>DYNAMIC CHARACTERISTICS</b>									
Output Voltage Swing	$f=1KHz$	4	$\pm 110$	$\pm 115$	-	$\pm 110$	$\pm 115$	-	V
Peak Output Current ②	$f=1KHz$	-	$\pm 200$	$\pm 250$	-	$\pm 200$	$\pm 250$	-	mA
Full Power Output ②	$V_O = \pm 100V$	-	1	2	-	1	2	-	MHz
Unity Gain Bandwidth ②	$V_O = \pm 1.0V$	-	50	70	-	50	70	-	MHz
Slew Rate	$V_O = \pm 90V$	4	2000	3000	-	1500	3000	-	$V/\mu S$
Voltage Gain ②	$f=1KHz$	4	90	95	-	90	95	-	dB
Settling Time to 1% ②	$A_V = -10V/V$	-	-	250	-	-	250	-	nS
Settling Time to 0.1% ②	$A_V = -10V/V$	-	-	1200	-	-	1200	-	nS

### NOTES:

- ① Unless otherwise specified,  $\pm V_{CC} = \pm 15V_{DC}$ ,  $\pm V_{HV} = \pm 120V_{DC}$ ,  $C_L = 8pF$  (probe capacitance) and  $A_V = -10V/V$ .
- ② This parameter is guaranteed by design but not tested. Typical parameters are representative of actual device performance but are for reference only.
- ③ Industrial grade devices shall be tested to subgroups 1 and 4 unless otherwise specified.
- ④ Military grade devices ('B' suffix) shall be 100% tested to subgroups 1,2,3 and 4.
- ⑤ Subgroup 1,4  $T_A = T_C = +25^{\circ}C$   
Subgroup 2,5  $T_A = T_C = +125^{\circ}C$   
Subgroup 3,6  $T_A = T_C = -55^{\circ}C$

## APPLICATION NOTES

### FEED FORWARD TOPOLOGY

The MSK 601 employs a circuit topology known as "feed forward". This inverting configuration allows the user to realize the excellent D.C. characteristics of a differential amplifier without losing system bandwidth. The incoming signal is split at the input into its A.C. and D.C. component. The D.C. component is allowed to run through the differential amplifier where any common mode noise is rejected. The A.C. component is "fed forward" to the output section through a very high speed linear amplifier where it is mixed back together with the D.C. component. The result is an amplifier with most of the benefits of a differential amplifier without the loss in system bandwidth.

### HIGH VOLTAGE SUPPLIES

The positive and negative high voltage supplies on the MSK 601 can be adjusted to reduce power dissipation. The output of the MSK 601 will typically swing to within 8V of either high voltage power supply rail. Therefore, if the system in question only needs the output of the amplifier to swing  $\pm 40V$  peak, the power supply rails could be set to  $\pm 50V$ . For best performance, the minimum value of  $\pm V_{HV}$  should be  $\pm 50V_{DC}$ . Unbalanced power supply rails are also allowed as long as one or the other is not decreased to below 30V or above 150V. The high voltage and low voltage power supplies should be decoupled as shown in Figure 1.

### TRANSITION TIMES

Transition time optimization of the MSK 601 follows the same basic rules as most any other amplifier. Best transition times will be realized with minimum load capacitance, minimum external feedback resistance and lowest circuit gain. Transition times will degrade if the output is driven too close to either supply rail. Feedback and input resistor values will affect transition time as well. See Figure 1 and Table 1 for recommended component values.

VOLTAGE GAIN	-R <sub>IN</sub>	R <sub>F</sub>	C <sub>F</sub>
-10V/V	1K $\Omega$	10K $\Omega$	0.5-5pF
-20V/V	499 $\Omega$	10K $\Omega$	N/A
-50V/V	402 $\Omega$	20K $\Omega$	N/A

Table 1

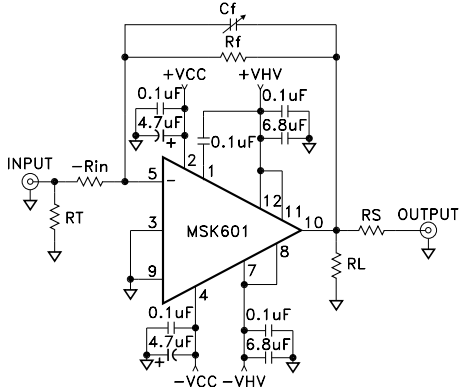

Figure 1

### INTERNAL COMPENSATION

Since the MSK 601 is a high voltage amplifier, it is commonly used in circuits employing large gains. Therefore, the internal compensation was chosen for gains of  $-5V/V$  or greater. In circuits running at gains of less than  $-5V/V$ , the user can further compensate the device by adding compensation networks at the input or feedback node. Pin 1 (comp) should be bypassed with a 0.1uF ceramic capacitor to +VHV for all applications.

### CURRENT LIMIT

Figure 2 is the recommended active short circuit protection scheme for the MSK 601. The following formula may be used for setting current limit:

$$\text{Current Limit} \approx 0.6V / R_{sc}$$

R<sub>BASE</sub> must be selected based on the value of  $\pm V_{HV}$  as follows:

$$R_{BASE} = ((+V_{HV} - (-V_{HV})) - 1.2V) / 4mA$$

This formula guarantees that Q2 and Q4 will always have sufficient base current to be in operation. This circuit can be made tolerant of high frequency output current spikes with the addition of C<sub>sc</sub>. The corresponding time constant would be:

$$T = (R_{sc}) (C_{sc})$$

A common value for C<sub>sc</sub> is approximately 1000pF. If current limit is unnecessary, short pin 7 to pin 8 and pin 11 to pin 12 as shown in Figure 1.

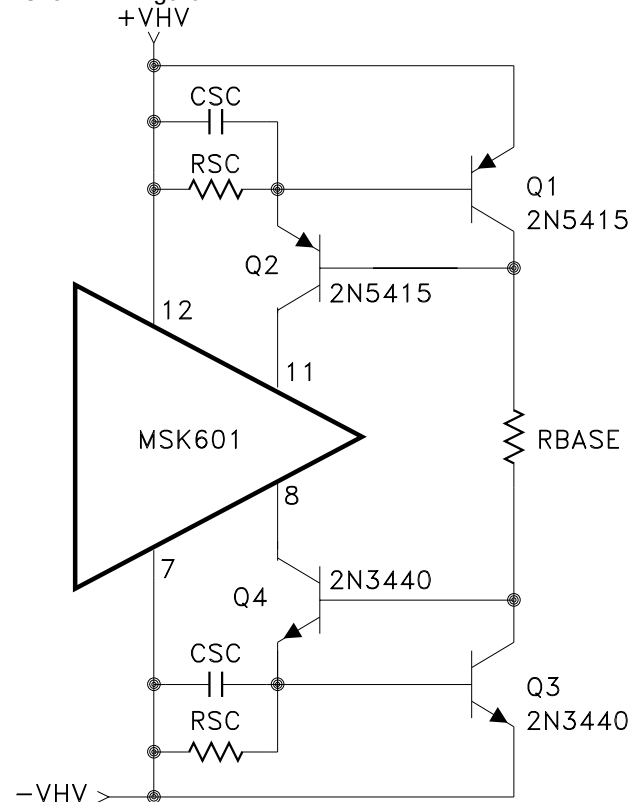
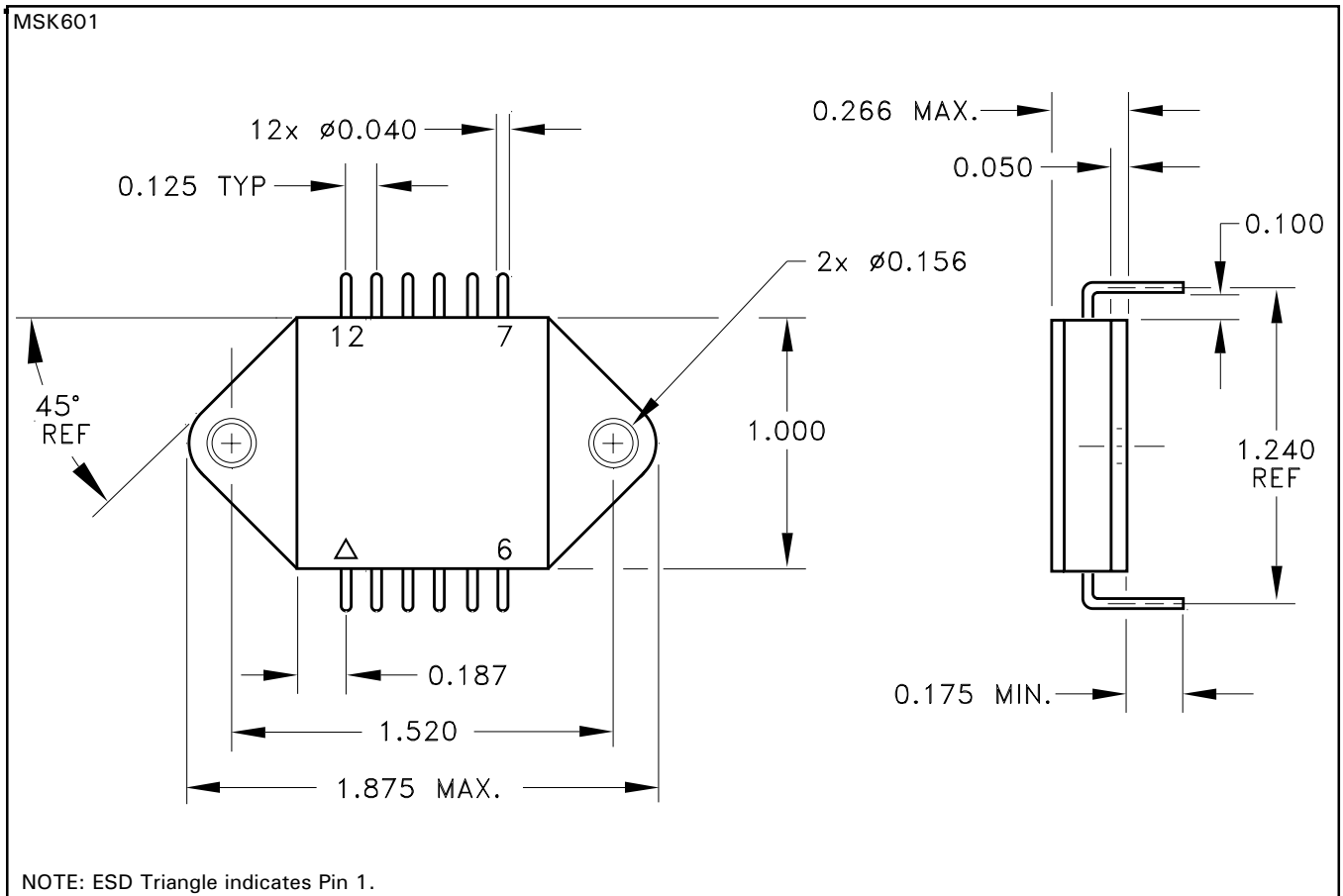

Figure 2





# MECHANICAL SPECIFICATIONS



ALL DIMENSIONS ARE  $\pm 0.010$  INCHES UNLESS OTHERWISE LABELED

## ORDERING INFORMATION

Part Number	Screening Level
MSK601	Industrial
MSK601B	Military-Mil-PRF-38534

M.S. Kennedy Corp.  
 4707 Dey Road, Liverpool, New York 13088  
 Phone (315) 701-6751  
 FAX (315) 701-6752  
 www.mskennedy.com

The information contained herein is believed to be accurate at the time of printing. MSK reserves the right to make changes to its products or specifications without notice, however, and assumes no liability for the use of its products.