

QL4058 QuickRAM Data Sheet



••••• **58,000 Usable PLD Gate QuickRAM ESP Combining Performance, Density and Embedded RAM**

Device Highlights

High Performance & High Density

- 58,000 Usable PLD Gates with 252 I/Os
- 300 MHz 16-bit Counters, 400 MHz Datapaths, 160+ MHz FIFOs
- 0.35 μm four-layer metal non-volatile CMOS process for smallest die sizes

High Speed Embedded SRAM

- 18 dual-port RAM modules, organized in user-configurable 1,152 bit blocks
- 5 ns access times, each port independently accessible
- Fast and efficient for FIFO, RAM, and ROM functions

Easy to Use / Fast Development Cycles

- 100% routable with 100% utilization and complete pin-out stability
- Variable-grain logic cells provide high performance and 100% utilization
- Comprehensive design tools include high quality Verilog/VHDL synthesis

Advanced I/O Capabilities

- Interfaces with both 3.3 V and 5.0 V devices
- PCI compliant with 3.3 V and 5.0 V busses for -1/-2/-3/-4 speed grades
- Full JTAG boundary scan
- I/O Cells with individually controlled Registered Input Path and Output Enables

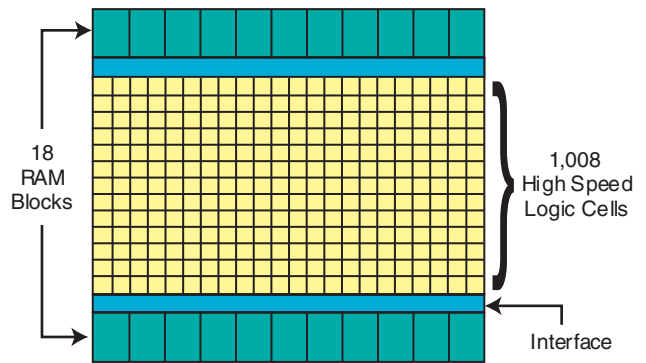

Figure 1: QuickRAM Block Diagram

Architecture Overview

The QuickRAM family of ESPs (Embedded Standard Products) offers FPGA logic in combination with Dual-Port SRAM modules. The QL4058 is a 58,000 usable PLD gate member of the QuickRAM family of ESPs. QuickRAM ESPs are fabricated on a 0.35 μm four-layer metal process using QuickLogic's patented ViaLink[®]™ technology to provide a unique combination of high performance, high density, low cost, and extreme ease-of-use.

The QL4058 contains 1,008 logic cells and 18 Dual Port RAM modules (see **Figure 1**). Each RAM module has 1,152 RAM bits, for a total of 20,736 bits. RAM Modules are Dual Port (one read port, one write port) and can be configured into one of four modes: 64 (deep) \times 18 (wide), 128 \times 9, 256 \times 4, or 512 \times 2 (see **Figure 4**). With a maximum of 252 I/Os, the QL4058 is available in 208-PQFP, 240-pin PQFP, and 456-pin PBGA packages.

Designers can cascade multiple RAM modules to increase the depth or width allowed in single modules by connecting corresponding address lines together and dividing the words between modules (see **Figure 2**). This approach allows up to 512-deep configurations as large as 16 bits wide in the smallest QuickRAM device and 44 bits wide in the largest device.

Software support for the complete QuickRAM family, including the QL4058, is available through two basic packages. The turnkey QuickWorks[®]™ package provides the most complete ESP software solution from design entry to logic synthesis, to place and route, to simulation. The QuickTools package provides a solution for designers who use Cadence, Exemplar, Mentor, Synopsys, Synplicity, Viewlogic, Aldec, or other third-party tools for design entry, synthesis, or simulation.

The QuickLogic[®]™ variable grain logic cell features up to 16 simultaneous inputs and five outputs within a cell that can be fragmented into five independent cells. Each cell has a fan-in of 29 including register and control lines (see **Figure 3**).

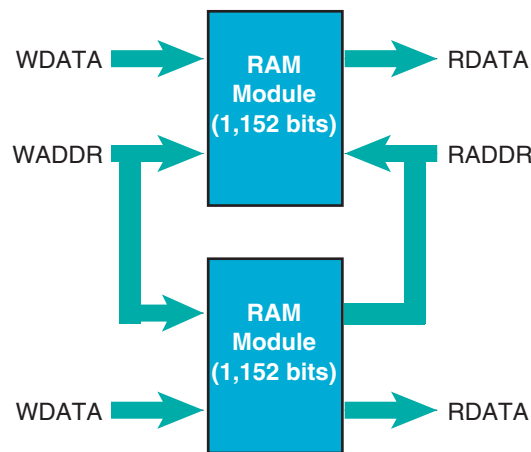

Figure 2: QuickRAM Module Bits

Product Summary

Total of 252 I/O Pins

- 244 bi-directional input/output pins, PCI-compliant for 5.0 V and 3.3 V buses for -1/-2/-3/-4 speed grades
- 8 high-drive input/distributed network pins

Eight Low-Skew Distributed Networks

- Two array clock/control networks available to the logic cell flip-flop clock, set and reset inputs—each driven by an input-only pin
- Six global clock/control networks available to the logic cell F1, clock, set and reset inputs and the input and I/O register clock, reset and enable inputs as well as the output enable control—each driven by an input-only or I/O pin, or any logic cell output or I/O cell feedback

High Performance Silicon

- Input + logic cell + output total delays = under 6 ns
- Data path speeds over 400 MHz
- Counter speeds over 300 MHz
- FIFO speeds over 160+ MHz

Electrical Specifications

AC Characteristics at $V_{CC} = 3.3\text{ V}$, $T_A = 25^\circ\text{C}$ ($K = 1.00$)

To calculate delays, multiply the appropriate K factor from **Table 10: Operating Range** by the following numbers in the tables provided.

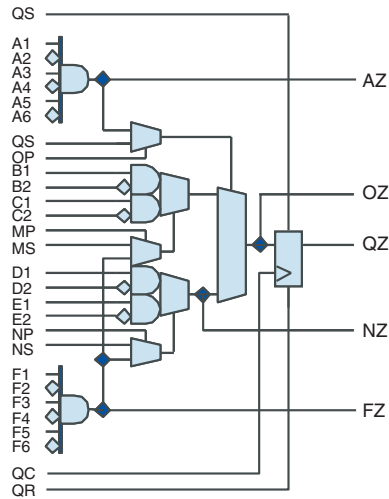

Figure 3: QuickRAM Logic Cell

Table 1: Logic Cell

Symbol	Parameter	Propagation Delays (ns) Fanout (5)				
		1	2	3	4	5
t_{PD}	Combinatorial Delay ^a	1.4	1.7	1.9	2.2	3.2
t_{SU}	Setup Time ^a	1.7	1.7	1.7	1.7	1.7
t_H	Hold Time	0.0	0.0	0.0	0.0	0.0
t_{CLK}	Clock to Q Delay	0.7	1.0	1.2	1.5	2.5
t_{CWHI}	Clock High Time	1.2	1.2	1.2	1.2	1.2
t_{CWLO}	Clock Low Time	1.2	1.2	1.2	1.2	1.2
t_{SET}	Set Delay	1.0	1.3	1.5	1.8	2.8
t_{RESET}	Reset Delay	0.8	1.1	1.3	1.6	2.6
t_{SW}	Set Width	1.9	1.9	1.9	1.9	1.9
t_{RW}	Reset Width	1.8	1.8	1.8	1.8	1.8

a. These limits are derived from a representative selection of the slowest paths through the QuickRAM logic cell including typical net delays. Worst case delay values for specific paths should be determined from timing analysis of your particular design.

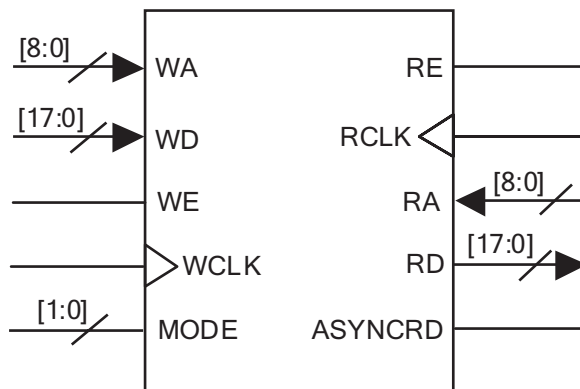

Figure 4: QuickRAM Module

Table 2: RAM Cell Synchronous Write Timing

Symbol	Parameter	Propagation Delays (ns) Fanout				
		1	2	3	4	5
t _{SWA}	WA Setup Time to WCLK	1.0	1.0	1.0	1.0	1.0
t _{HWA}	WA Hold Time to WCLK	0.0	0.0	0.0	0.0	0.0
t _{SWD}	WD Setup Time to WCLK	1.0	1.0	1.0	1.0	1.0
t _{HWD}	WD Hold Time to WCLK	0.0	0.0	0.0	0.0	0.0
t _{SWE}	WE Setup Time to WCLK	1.0	1.0	1.0	1.0	1.0
t _{HWE}	WE Hold Time to WCLK	0.0	0.0	0.0	0.0	0.0
t _{WCRD}	WCLK to RD (WA=RA) ^a	5.0	5.3	5.6	5.9	7.1

a. Stated timing for worst case Propagation Delay over process variation at V_{CC} = 3.3 V and TA = 25°C. Multiply by the appropriate Delay Factor, K, for speed grade, voltage and temperature settings as specified in the Operating Range.

Table 3: RAM Cell Synchronous Read Timing

Symbol	Parameter	Propagation Delays (ns) Fanout				
		1	2	3	4	5
Logic Cells						
t _{SRA}	RA Setup Time to RCLK	1.0	1.0	1.0	1.0	1.0
t _{HRA}	RA Hold Time to RCLK	0.0	0.0	0.0	0.0	0.0
t _{SRE}	RE Setup Time to RCLK	1.0	1.0	1.0	1.0	1.0
t _{HRE}	RE Hold Time to RCLK	0.0	0.0	0.0	0.0	0.0
t _{RCD}	RCLK to RD ^a	4.0	4.3	4.6	4.9	6.1

a. Stated timing for worst case Propagation Delay over process variation at V_{CC} = 3.3 V and TA = 25°C. Multiply by the appropriate Delay Factor, K, for speed grade, voltage and temperature settings as specified in the Operating Range.

Table 4: RAM Cell Asynchronous Read Timing

Symbol	Parameter	Propagation Delays (ns) Fanout				
		1	2	3	4	5
RPDRD	RA to RD ^a	3.0	3.3	3.6	3.9	5.1

a. Stated timing for worst case Propagation Delay over process variation at $V_{CC} = 3.3\text{ V}$ and $T_A = 25^\circ\text{C}$. Multiply by the appropriate Delay Factor, K, for speed grade, voltage and temperature settings as specified in the Operating Range.

Table 5: Input-Only / Clock Cells

Symbol	Parameter	Propagation Delays (ns) Fanout						
		1	2	3	4	8	12	24
t_{IN}	High Drive Input Delay	1.5	1.6	1.8	1.9	2.4	2.9	4.4
t_{INI}	High Drive Input, Inverting Delay	1.6	1.7	1.9	2.0	2.5	3.0	4.5
t_{ISU}	Input Register Set-Up Time	3.1	3.1	3.1	3.1	3.1	3.1	3.1
t_{IH}	Input Register Hold Time	0.0	0.0	0.0	0.0	0.0	0.0	0.0
t_{iCLK}	Input Register Clock To Q	0.7	0.8	1.0	1.1	1.6	2.1	3.6
t_{IRST}	Input Register Reset Delay	0.6	0.7	0.9	1.0	1.5	2.0	3.5
t_{IESU}	Input Register Clock Enable Setup Time	2.3	2.3	2.3	2.3	2.3	2.3	2.3
t_{IEH}	Input Register Clock Enable Hold Time	0.0	0.0	0.0	0.0	0.0	0.0	0.0

Table 6: Clock Cells

Symbol	Parameter	Propagation Delays (ns) Fanout ^a						
		1	2	3	4	8	10	11
t_{ACK}	Array Clock Delay	1.2	1.2	1.3	1.3	1.5	1.6	1.7
t_{GCKP}	Global Clock Pin Delay	0.7	0.7	0.7	0.7	0.7	0.7	0.7
t_{GCKB}	Global Clock Buffer Delay	0.8	0.8	0.9	0.9	1.1	1.2	1.3

a. The array distributed networks consist of 40 half columns and the global distributed networks consist of 44 half columns, each driven by an independent buffer. The number of half columns used does not affect clock buffer delay. The array clock has up to eight loads per half column. The global clock has up to 11 loads per half column.

Table 7: I/O Cell Input Delays

Symbol	Parameter	Propagation Delays (ns) Fanout ^a					
		1	2	3	4	8	10
t _{I/O}	Input Delay (bidirectional pad)	1.3	1.6	1.8	2.1	3.1	3.6
t _{ISU}	Input Register Set-Up Time	3.1	3.1	3.1	3.1	3.1	3.1
t _{IH}	Input Register Hold Time	0.0	0.0	0.0	0.0	0.0	0.0
t _{IOCLK}	Input Register Clock to Q	0.7	1.0	1.2	1.5	2.5	3.0
t _{IORST}	Input Register Reset Delay	0.6	0.9	1.1	1.4	2.4	2.9
t _{IESU}	Input Register Clock Enable Set-Up Time	2.3	2.3	2.3	2.3	2.3	2.3
t _{IEH}	Input Register Clock Enable Hold Time	0.0	0.0	0.0	0.0	0.0	0.0

a. Stated timing for worst case Propagation Delay over process variation at V_{CC} = 3.3 V and TA = 25°C. Multiply by the appropriate Delay Factor, K, for speed grade, voltage and temperature settings as specified in the Operating Range.

Table 8: I/O Cell Output Delays

Symbol	Parameter	Propagation Delays (ns) Output Load Capacitance (pF)				
		3	50	75	100	150
t _{OUTLH}	Output Delay Low to High	2.1	2.5	3.1	3.6	4.7
t _{OUTH}	Output Delay High to Low	2.2	2.6	3.2	3.7	4.8
t _{PZH}	Output Delay Tri-state to High	1.2	1.7	2.2	2.8	3.9
t _{PZL}	Output Delay Tri-state to Low	1.6	2.0	2.6	3.1	4.2
t _{PHZ}	Output Delay High to Tri-state ^a	2.0	-	-	-	-
t _{PLZ}	Output Delay High to Tri-state ^a	1.2	-	-	-	-

a. These loads are used for t_{PXZ} (see Figure 5)

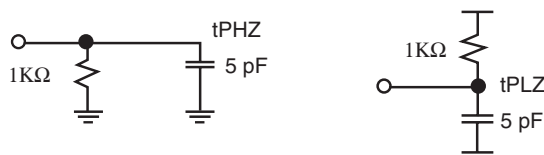

Figure 5: Loads used for t_{PXZ}

DC Characteristics

The DC specifications are provided in the tables below.

Table 9: Absolute Maximum Ratings

Parameter	Value	Parameter	Value
V _{CC} Voltage	-0.5 V to 4.6 V	DC Input Current	±20 mA
V _{CCIO} Voltage	-0.5 V to 7.0 V	ESD Pad Protection	±2000 V
Input Voltage	-0.5 V to V _{CCIO} +0.5 V	Storage Temperature	-65°C to +150°C
Latch-up Immunity	±200 mA	Lead Temperature	300°C

Table 10: Operating Range

Symbol	Parameter	Military		Industrial		Commercial		Unit	
		Min	Max	Min	Max	Min	Max		
V _{CC}	Supply Voltage	3.0	3.6	3.0	3.6	3.0	3.6	V	
V _{CCIO}	I/O Input Tolerance Voltage	3.0	5.5	3.0	5.5	3.0	5.25	V	
TA	Ambient Temperature	-55	-	-40	85	0	70	°C	
TC	Case Temperature	-	125	-	-	-	-	°C	
K	Delay Factor	-0 Speed Grade	0.42	2.03	0.43	1.90	0.46	1.85	n/a
		-1 Speed Grade	0.42	1.64	0.43	1.54	0.46	1.50	n/a
		-2 Speed Grade	0.42	1.37	0.43	1.28	0.46	1.25	n/a
		-3 Speed Grade			0.43	0.90	0.46	0.88	n/a
		-4 Speed Grade			0.43	0.82	0.46	0.80	n/a

Table 11: DC Characteristics

Symbol	Parameter	Conditions	Min	Max	Units
VIH	Input HIGH Voltage		$0.5 V_{CC}$	$V_{CCIO} + 0.5$	V
VIL	Input LOW Voltage		-0.5	$0.3 V_{CC}$	V
VOH	Output HIGH Voltage	IOH = -12 mA	2.4		V
		IOH = -500 μ A	$0.9V_{CC}$		V
VOL	Output LOW Voltage	IOL = 16 mA ^a		0.45	V
		IOL = 1.5 mA		$0.1 V_{CC}$	V
II	I or I/O Input Leakage Current	VI = V_{CCIO} or GND	-10	10	μ A
IOZ	3-State Output Leakage Current	VI = V_{CCIO} or GND	-10	10	μ A
CI	Input Capacitance ^b			10	pF
IOS	Output Short Circuit Current ^c	VO = GND	-15	-180	mA
		VO = VCC	40	210	mA
ICC	D.C. Supply Current ^d	VI, VIO = V_{CCIO} or GND	0.50 (typ)	2	mA
ICCIO	D.C. Supply Current on VCCIO		0	100	μ A

- a. Applies only to -1/-2/-3/-4 commercial grade devices. These speed grades are also PCI-compliant. All other devices have 8 mA IOL specifications.
- b. Capacitance is sample tested only. Clock pins are 12 pF maximum.
- c. Only one output at a time. Duration should not exceed 30 seconds.
- d. For -1/-2/-3/-4 commercial grade devices only. Maximum ICC is 3 mA for -0 commercial grade and all industrial grade devices and 5 mA for all military grade devices. For AC conditions, contact QuickLogic customer applications group (see [Contact Information](#))

Kv and Kt Graphs

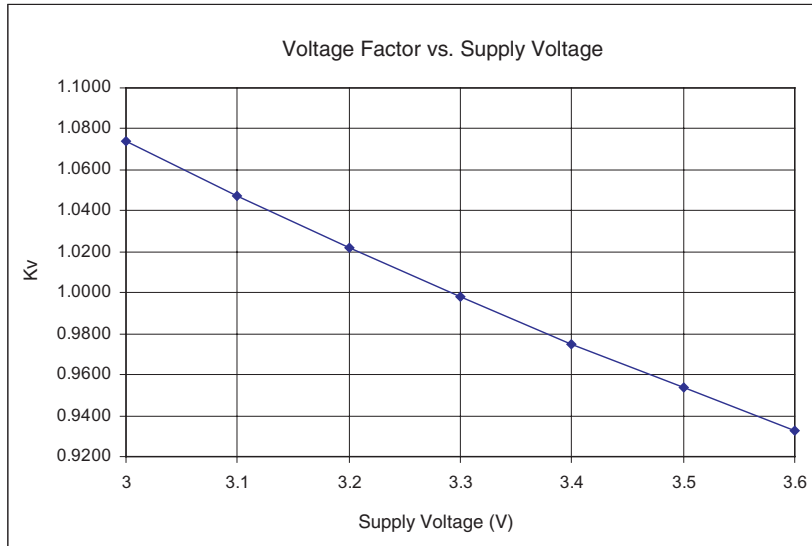

Figure 6: Voltage Factor vs. Supply Voltage

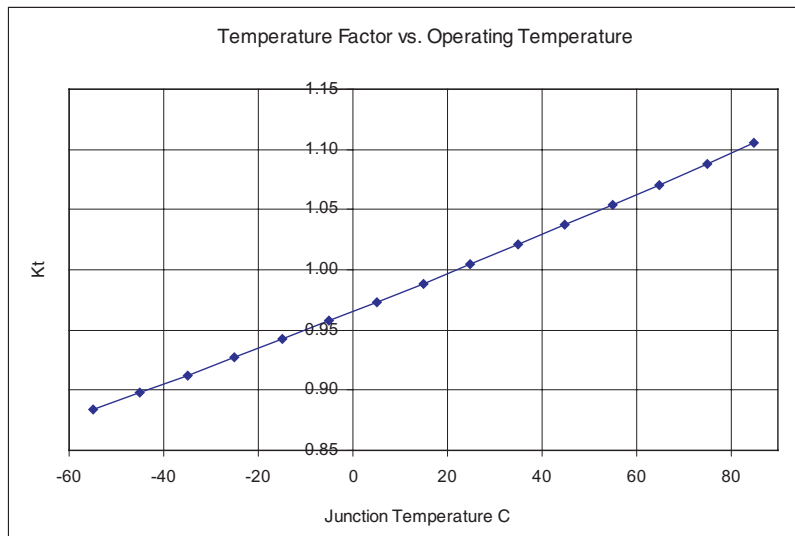

Figure 7: Temperature Factor vs. Operating Temperature

Power-up Sequencing

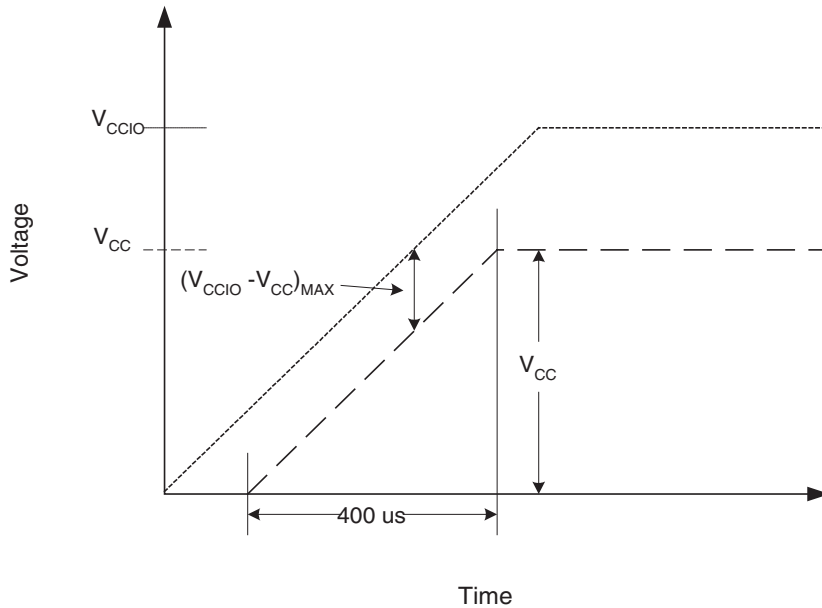

Figure 8: Power-up Requirements

The following requirements must be met when powering up the device (see **Figure 8**):

- When ramping up the power supplies keep $(V_{CCIO} - V_{CC})_{MAX} \leq 500$ mV. Deviation from this recommendation can cause permanent damage to the device.
- V_{CCIO} must lead V_{CC} when ramping the device.
- The power supply must take greater than or equal to $400 \mu s$ to reach V_{CC} . Ramping to V_{CC}/V_{CCIO} earlier than $400 \mu s$ can cause the device to behave improperly.

An internal diode is present in-between V_{CC} and V_{CCIO} , as shown in **Figure 9**.

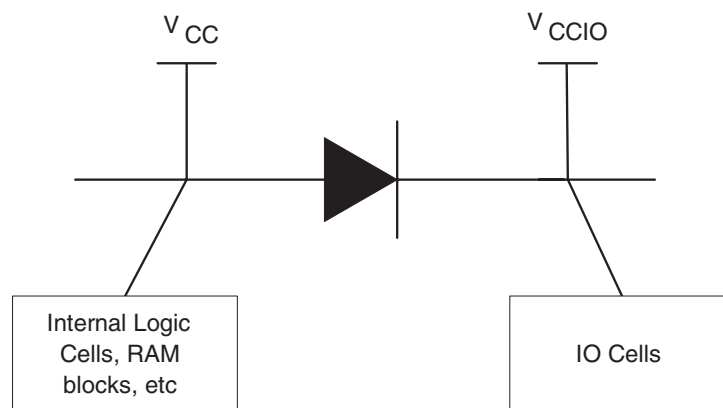

Figure 9: Internal Diode Between VCC and VCCIO

JTAG

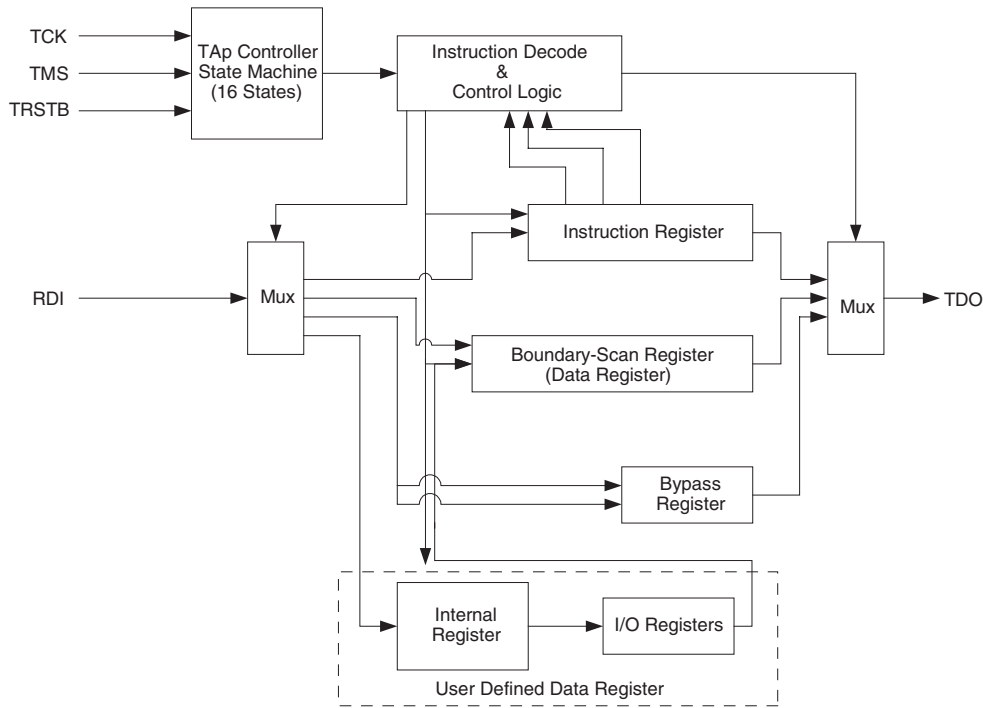

Figure 10: JTAG Block Diagram

Microprocessors and Application Specific Integrated Circuits (ASICs) pose many design challenges. One of these challenges concerns the accessibility of test points. The Joint Test Access Group (JTAG) formed in response to this challenge, resulting in IEEE standard 1149.1, the Standard Test Access Port and Boundary Scan Architecture.

The JTAG boundary scan test methodology allows complete observation and control of the boundary pins of a JTAG-compatible device through JTAG software. A Test Access Port (TAP) controller works in concert with the Instruction Register (IR); these allow users to run three required tests, along with several user-defined tests.

JTAG tests allow users to reduce system debug time, reuse test platforms and tools, and reuse subsystem tests for fuller verification of higher level system elements.

The JTAG 1149.1 standard requires the following three tests:

- **Extest Instruction.** The Extest instruction performs a PCB interconnect test. This test places a device into an external boundary test mode, selecting the boundary scan register to be connected between the TAP's Test Data In (TDI) and Test Data Out (TDO) pins. Boundary scan cells are preloaded with test patterns (via the Sample/Preload Instruction), and input boundary cells capture the input data for analysis.
- **Sample/Preload Instruction.** This instruction allows a device to remain in its functional mode, while selecting the boundary scan register to be connected between the TDI and TDO pins. For this test, the boundary scan register can be accessed via a data scan operation, allowing users to sample the functional data entering and leaving the device.
- **Bypass Instruction.** The Bypass instruction allows data to skip a device's boundary scan entirely, so the data passes through the bypass register. The Bypass instruction allows users to test a device without passing through other devices. The bypass register connects the TDI and TDO pins, allowing serial data to be transferred through a device without affecting the operation of the device.

Pin Descriptions

Table 12: Pin Descriptions

Pin	Function	Description
TDI/RSI	Test Data In for JTAG /RAM init. Serial Data In	Hold HIGH during normal operation. Connects to serial PROM data in for RAM initialization. Connect to V _{CC} if unused.
TRSTB/RRO	Active low Reset for JTAG /RAM init. reset out	Hold LOW during normal operation. Connects to serial PROM reset for RAM initialization. Connect to GND if unused.
TMS	Test Mode Select for JTAG	Hold HIGH during normal operation. Connect to VCC if not used for JTAG.
TCK	Test Clock for JTAG	Hold HIGH or LOW during normal operation. Connect to V _{CC} or ground if not used for JTAG.
TDO/RCO	Test data out for JTAG /RAM init. clock out	Connect to serial PROM clock for RAM initialization. Must be left unconnected if not used for JTAG or RAM initialization.
STM	Special Test Mode	Must be grounded during normal operation.
I/ACLK	High-drive input and/or array network driver	Can be configured as either or both.
I/GCLK	High-drive input and/or global network driver	Can be configured as either or both.
I	High-drive input	Use for input signals with high fanout.
I/O	Input/Output pin	Can be configured as an input and/or output.
VCC	Power supply pin	Connect to 3.3 V supply.
VCCIO	Input voltage tolerance pin	Connect to 5.0 V supply if 5 V input tolerance is required, otherwise connect to 3.3 V supply.
GND	Ground pin	Connect to ground.
GND/THERM	Ground/Thermal pin	Available on 456-PBGA only. Connect to ground plane on PCB if heat sinking desired. Otherwise may be left unconnected.

Ordering Information

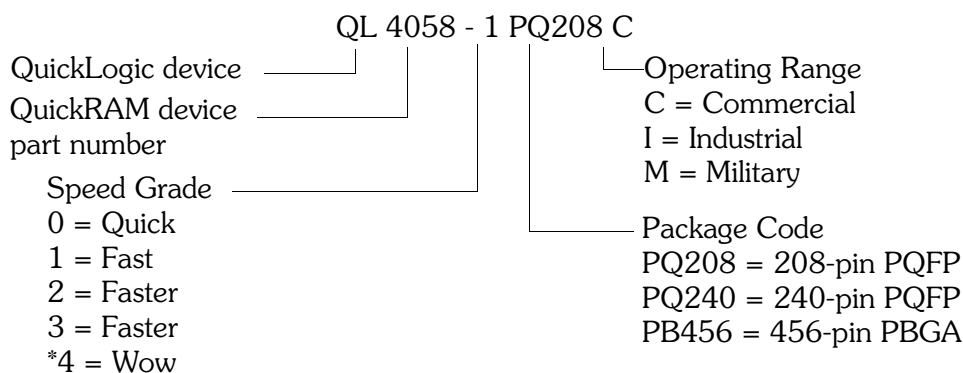

* Contact QuickLogic regarding availability

208 and 240 PQFP Pinout Diagrams

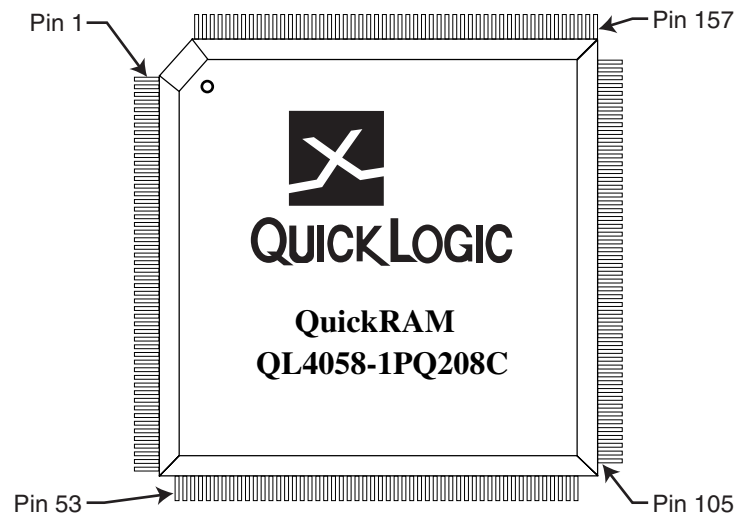

Figure 11: Top View of 208 Pin PQFP

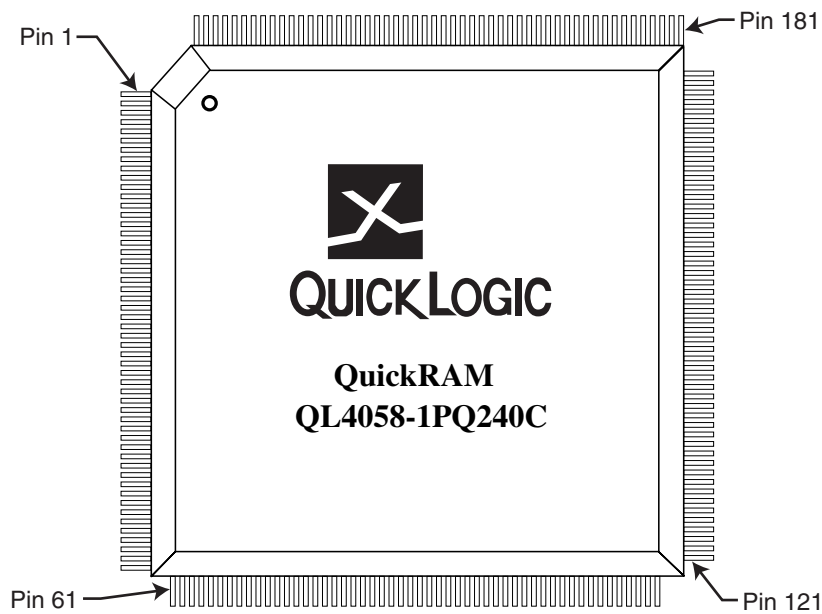

Figure 12: Top View of 240 Pin PQFP

208 and 240 PQFP Pinout Table

Table 13: 208/240 PQFP Pinout Table

240 PQFP	208 PQFP	Function	240 PQFP	208 PQFP	Function	240 PQFP	208 PQFP	Function	240 PQFP	208 PQFP	Function	240 PQFP	208 PQFP	Function
1	208	I/O	51	43	GND	98	84	I/O	145	125	I/O	194	168	I/O
2	1	I/O	52	44	I/O	99	85	I/O	146	126	I/O	195	169	I/O
3	2	I/O	53	45	I/O	100	86	I/O	147	127	GND	196	NC	I/O
4	3	I/O	54	46	I/O	101	87	I/O	148	128	I/O	197	170	I/O
5	4	I/O	55	47	I/O	102	88	I/O	149	NC	I/O	198	171	I/O
6	5	I/O	56	48	I/O	103	89	I/O	150	129	GLCK/I	199	172	I/O
7	NC	I/O	57	NC	I/O	104	90	I/O	151	130	ACLK/I	200	173	I/O
8	6	I/O	58	49	I/O	105	91	I/O	152	131	VCC	201	174	I/O
9	7	I/O	59	50	I/O	106	92	I/O	153	132	GLCK/I	202	175	I/O
10	8	I/O	60	51	I/O	107	NC	I/O	154	133	GLCK/I	203	NC	I/O
11	9	I/O	NC	52	I/O	108	93	I/O	155	134	VCC	204	176	I/O
12	10	VCC	NC	53	I/O	109	94	I/O	156	135	I/O	205	177	GND
13	11	I/O	61	54	TDI	110	95	GND	157	136	I/O	206	178	I/O
14	12	GND	62	NC	I/O	NC	96	I/O	158	NC	I/O	207	179	I/O
15	13	I/O	63	NC	I/O	111	97	VCC	159	137	I/O	208	NC	I/O
16	14	I/O	64	55	I/O	NC	98	I/O	160	NC	GND	209	180	I/O
17	NC	I/O	65	56	I/O	NC	99	I/O	161	138	I/O	210	181	I/O
18	15	I/O	66	NC	I/O	112	100	I/O	162	139	I/O	211	182	GND
19	16	I/O	67	57	I/O	113	NC	I/O	163	140	I/O	212	NC	VCC
20	17	I/O	68	58	I/O	114	101	I/O	164	141	I/O	213	183	I/O
21	18	I/O	69	59	GND	115	NC	I/O	165	142	I/O	214	184	I/O
22	19	I/O	70	60	I/O	116	102	I/O	166	NC	I/O	215	185	I/O
23	20	I/O	71	61	VCC	117	NC	I/O	167	143	I/O	216	186	I/O
24	NC	I/O	72	62	I/O	118	NC	I/O	168	144	I/O	217	187	VCCIO
25	21	I/O	73	63	I/O	119	103	TRSTB	169	145	VCC	218	188	I/O
26	22	I/O	74	64	I/O	120	104	TMS	170	NC	I/O	219	NC	I/O
27	23	GND	75	NC	I/O	121	105	I/O	171	146	I/O	220	189	I/O
28	24	I/O	76	65	I/O	122	NC	I/O	172	147	GND	221	190	I/O
29	25	GCLK/I	77	66	I/O	123	106	I/O	173	148	I/O	222	191	I/O
30	26	ACLK/I	78	67	I/O	124	107	I/O	174	149	I/O	223	192	I/O
31	27	VCC	79	NC	I/O	125	108	I/O	175	150	I/O	224	193	I/O
32	28	GCLK/I	80	68	I/O	126	109	I/O	176	151	I/O	225	194	I/O
33	29	GCLK/I	81	69	I/O	127	NC	I/O	177	152	I/O	226	NC	I/O
34	30	VCC	82	70	I/O	128	110	I/O	178	153	I/O	227	195	I/O
35	31	I/O	83	NC	I/O	129	111	I/O	179	154	I/O	228	196	I/O
36	32	I/O	NC	71	I/O	130	112	I/O	180	155	I/O	229	197	I/O
37	NC	GND	84	NC	I/O	131	113	I/O	NC	156	I/O	230	198	I/O
38	33	I/O	85	72	I/O	132	114	VCC	181	157	TCK	231	NC	I/O
39	NC	I/O	86	73	GND	133	115	I/O	182	158	STM	232	199	GND
40	34	I/O	87	74	I/O	134	116	GND	183	NC	I/O	233	200	I/O
41	35	I/O	88	NC	VCC	135	117	I/O	184	159	I/O	234	201	VCC
42	36	I/O	89	75	I/O	136	NC	I/O	185	160	I/O	235	202	I/O
43	NC	I/O	90	76	I/O	137	118	I/O	186	161	I/O	236	203	I/O
44	37	I/O	91	77	I/O	138	119	I/O	187	162	I/O	237	204	I/O
45	38	I/O	92	78	GND	139	120	I/O	188	163	GND	238	205	I/O
46	39	I/O	93	79	I/O	140	121	I/O	189	164	I/O	239	206	I/O
47	NC	I/O	94	80	I/O	141	NC	I/O	190	165	VCC	240	207	TDO
48	40	I/O	95	81	I/O	142	122	I/O	191	166	I/O			
49	41	VCC	96	82	I/O	143	123	I/O	192	NC	I/O			
50	42	I/O	97	83	VCCIO	144	124	I/O	193	167	I/O			

208 and 240 PQFP Mechanical Drawing

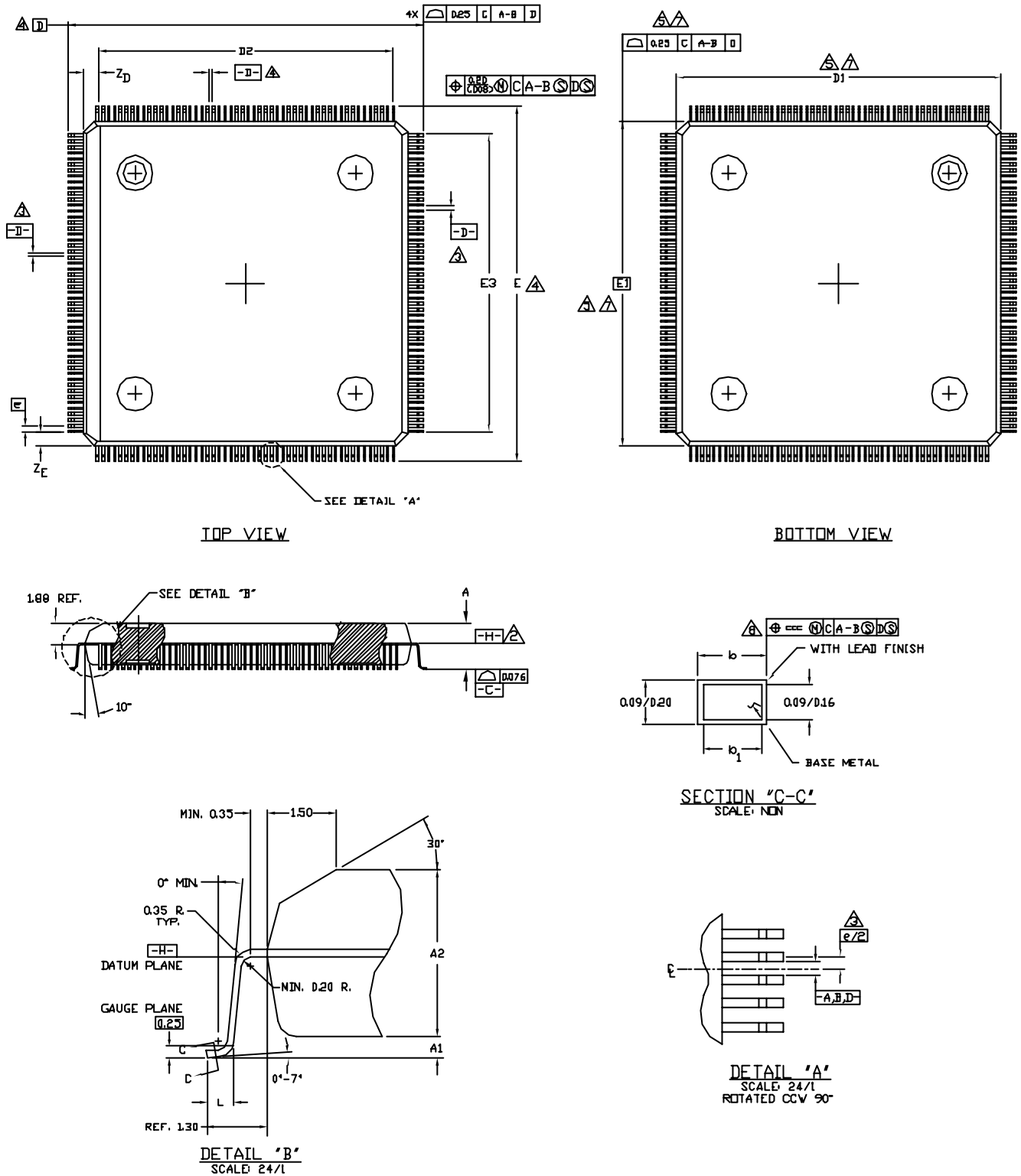

Figure 13: 208 PQFP Mechanical Drawing

456 PBGA Pinout Diagram

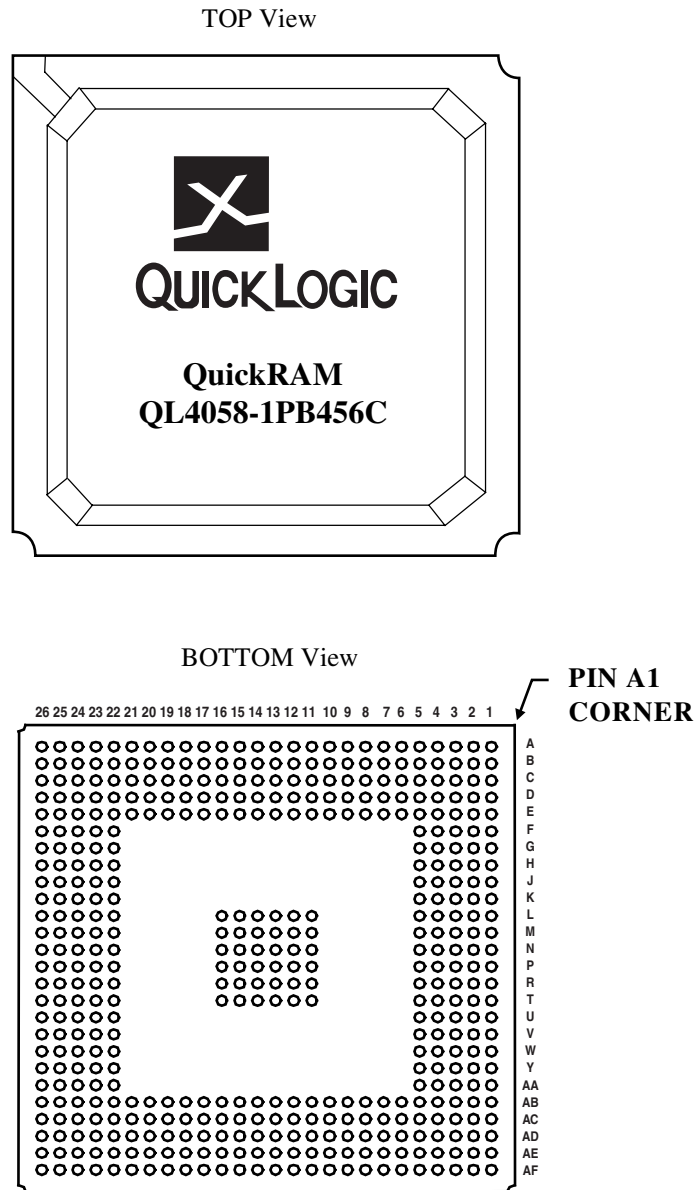

Figure 14: 456 PBGA Pinout Diagram

456 PBGA Pinout Table

Table 14: 456 PBGA Pinout Table

456	Function	456	Function	456	Function	456	Function	456	Function
A1	I/O	C1	I/O	E1	I/O	H23	NC	M23	NC
A2	I/O	C2	I/O	E2	I/O	H24	I/O	M24	I/O
A3	I/O	C3	I/O	E3	I/O	H25	NC	M25	I/O
A4	I/O	C4	TDO	E4	I/O	H26	I/O	M26	I/O
A5	I/O	C5	I/O	E5	GND	J1	I/O	N1	GCLK/I
A6	I/O	C6	I/O	E6	VCC	J2	I/O	N2	I/O
A7	I/O	C7	I/O	E7	GND	J3	I/O	N3	I/O
A8	I/O	C8	I/O	E8	NC	J4	NC	N4	GCLK/I
A9	NC	C9	I/O	E9	GND	J5	GND	N5	VCC
A10	I/O	C10	I/O	E10	I/O	J22	NC	N11	GND/THERM
A11	I/O	C11	I/O	E11	GND	J23	NC	N12	GND/THERM
A12	VCCIO	C12	I/O	E12	GND	J24	I/O	N13	GND/THERM
A13	I/O	C13	I/O	E13	VCC	J25	I/O	N14	GND/THERM
A14	I/O	C14	I/O	E14	GND	J26	I/O	N15	GND/THERM
A15	NC	C15	I/O	E15	GND	K1	NC	N16	GND/THERM
A16	I/O	C16	I/O	E16	GND	K2	NC	N22	GND
A17	NC	C17	NC	E17	NC	K3	I/O	N23	I/O
A18	I/O	C18	NC	E18	GND	K4	I/O	N24	I/O
A19	I/O	C19	I/O	E19	NC	K5	VCC	N25	NC
A20	I/O	C20	I/O	E20	GND	K22	GND	N26	I/O
A21	NC	C21	I/O	E21	VCC	K23	I/O	P1	I/O
A22	I/O	C22	I/O	E22	GND	K24	I/O	P2	I/O
A23	NC	C23	I/O	E23	I/O	K25	NC	P3	NC
A24	I/O	C24	I/O	E24	I/O	K26	I/O	P4	I/O
A25	I/O	C25	TCK	E25	I/O	L1	I/O	P5	NC
A26	I/O	C26	NC	E26	I/O	L2	I/O	P11	GND/THERM
B1	I/O	D1	I/O	F1	I/O	L3	I/O	P12	GND/THERM
B2	NC	D2	I/O	F2	I/O	L4	I/O	P13	GND/THERM
B3	I/O	D3	I/O	F3	NC	L5	NC	P14	GND/THERM
B4	NC	D4	GND	F4	NC	L11	GND/THERM	P15	GND/THERM
B5	NC	D5	NC	F5	VCC	L12	GND/THERM	P16	GND/THERM
B6	NC	D6	NC	F22	VCC	L13	GND/THERM	P22	NC
B7	NC	D7	I/O	F23	NC	L14	GND/THERM	P23	GCLK / I
B8	NC	D8	I/O	F24	I/O	L15	GND/THERM	P24	GCLK / I
B9	I/O	D9	GND	F25	I/O	L16	GND/THERM	P25	NC
B10	NC	D10	I/O	F26	I/O	L22	NC	P26	ACLK / I
B11	NC	D11	I/O	G1	I/O	L23	I/O	R1	NC
B12	I/O	D12	GND	G2	I/O	L24	I/O	R2	I/O
B13	I/O	D13	I/O	G3	I/O	L25	NC	R3	I/O
B14	NC	D14	I/O	G4	I/O	L26	I/O	R4	NC
B15	I/O	D15	GND	G5	NC	M1	ACLK / I	R5	NC
B16	I/O	D16	I/O	G22	GND	M2	GCLK/I	R11	GND/THERM
B17	I/O	D17	I/O	G23	NC	M3	I/O	R12	GND/THERM
B18	I/O	D18	GND	G24	I/O	M4	NC	R13	GND/THERM
B19	I/O	D19	I/O	G25	I/O	M5	GND	R14	GND/THERM
B20	I/O	D20	NC	G26	I/O	M11	GND/THERM	R15	GND/THERM
B21	I/O	D21	NC	H1	NC	M12	GND/THERM	R16	GND/THERM
B22	I/O	D22	I/O	H2	I/O	M13	GND/THERM	R22	VCC
B23	NC	D23	GND	H3	NC	M14	GND/THERM	R23	NC
B24	I/O	D24	I/O	H4	I/O	M15	GND/THERM	R24	NC
B25	I/O	D25	I/O	H5	NC	M16	GND/THERM	R25	I/O
B26	STM	D26	I/O	H22	NC	M22	NC	R26	GCLK / I

(Sheet 1 of 2)

Table 14: 456 PBGA Pinout Table (Continued)

456	Function	456	Function	456	Function	456	Function	456	Function
T1	I/O	W5	NC	AB15	VCC	AD3	I/O	AE17	I/O
T2	I/O	W22	NC	AB16	I/O	AD4	I/O	AE18	I/O
T3	I/O	W23	I/O	AB17	NC	AD5	I/O	AE19	I/O
T4	I/O	W24	I/O	AB18	VCC	AD6	I/O	AE20	I/O
T5	VCC	W25	I/O	AB19	GND	AD7	I/O	AE21	I/O
T11	GND/THERM	W26	NC	AB20	NC	AD8	I/O	AE22	NC
T12	GND/THERM	Y1	NC	AB21	VCC	AD9	NC	AE23	NC
T13	GND/THERM	Y2	I/O	AB22	GND	AD10	I/O	AE24	TMS
T14	GND/THERM	Y3	NC	AB23	I/O	AD11	NC	AE25	I/O
T15	GND/THERM	Y4	I/O	AB24	NC	AD12	I/O	AE26	I/O
T16	GND/THERM	Y5	I/O	AB25	I/O	AD13	I/O	AF1	I/O
T22	GND	Y22	GND	AB26	I/O	AD14	I/O	AF2	NC
T23	I/O	Y23	I/O	AC1	I/O	AD15	I/O	AF3	I/O
T24	I/O	Y24	NC	AC2	I/O	AD16	I/O	AF4	NC
T25	NC	Y25	I/O	AC3	NC	AD17	I/O	AF5	I/O
T26	I/O	Y26	I/O	AC4	GND	AD18	I/O	AF6	I/O
U1	NC	AA1	I/O	AC5	NC	AD19	NC	AF7	I/O
U2	I/O	AA2	I/O	AC6	NC	AD20	NC	AF8	I/O
U3	I/O	AA3	NC	AC7	NC	AD21	I/O	AF9	I/O
U4	I/O	AA4	NC	AC8	NC	AD22	I/O	AF10	I/O
U5	GND	AA5	VCC	AC9	NC	AD23	TRSTB	AF11	NC
U22	NC	AA22	VCC	AC10	NC	AD24	NC	AF12	I/O
U23	I/O	AA23	NC	AC11	I/O	AD25	I/O	AF13	I/O
U24	I/O	AA24	I/O	AC12	NC	AD26	I/O	AF14	NC
U25	I/O	AA25	I/O	AC13	I/O	AE1	TDI	AF15	NC
U26	I/O	AA26	I/O	AC14	VCCIO	AE2	I/O	AF16	I/O
V1	I/O	AB1	NC	AC15	NC	AE3	I/O	AF17	I/O
V2	I/O	AB2	I/O	AC16	NC	AE4	I/O	AF18	I/O
V3	NC	AB3	I/O	AC17	NC	AE5	I/O	AF19	NC
V4	NC	AB4	I/O	AC18	NC	AE6	I/O	AF20	I/O
V5	NC	AB5	GND	AC19	I/O	AE7	I/O	AF21	I/O
V22	GND	AB6	VCC	AC20	I/O	AE8	I/O	AF22	I/O
V23	NC	AB7	NC	AC21	I/O	AE9	I/O	AF23	I/O
V24	I/O	AB8	NC	AC22	NC	AE10	I/O	AF24	I/O
V25	NC	AB9	NC	AC23	GND	AE11	I/O	AF25	I/O
V26	I/O	AB10	VCC	AC24	NC	AE12	I/O	AF26	I/O
W1	I/O	AB11	GND	AC25	I/O	AE13	I/O		
W2	I/O	AB12	NC	AC26	I/O	AE14	I/O		
W3	I/O	AB13	I/O	AD1	I/O	AE15	I/O		
W4	I/O	AB14	GND	AD2	NC	AE16	I/O		

(Sheet 2 of 2)

456 PBGA Mechanical Drawing

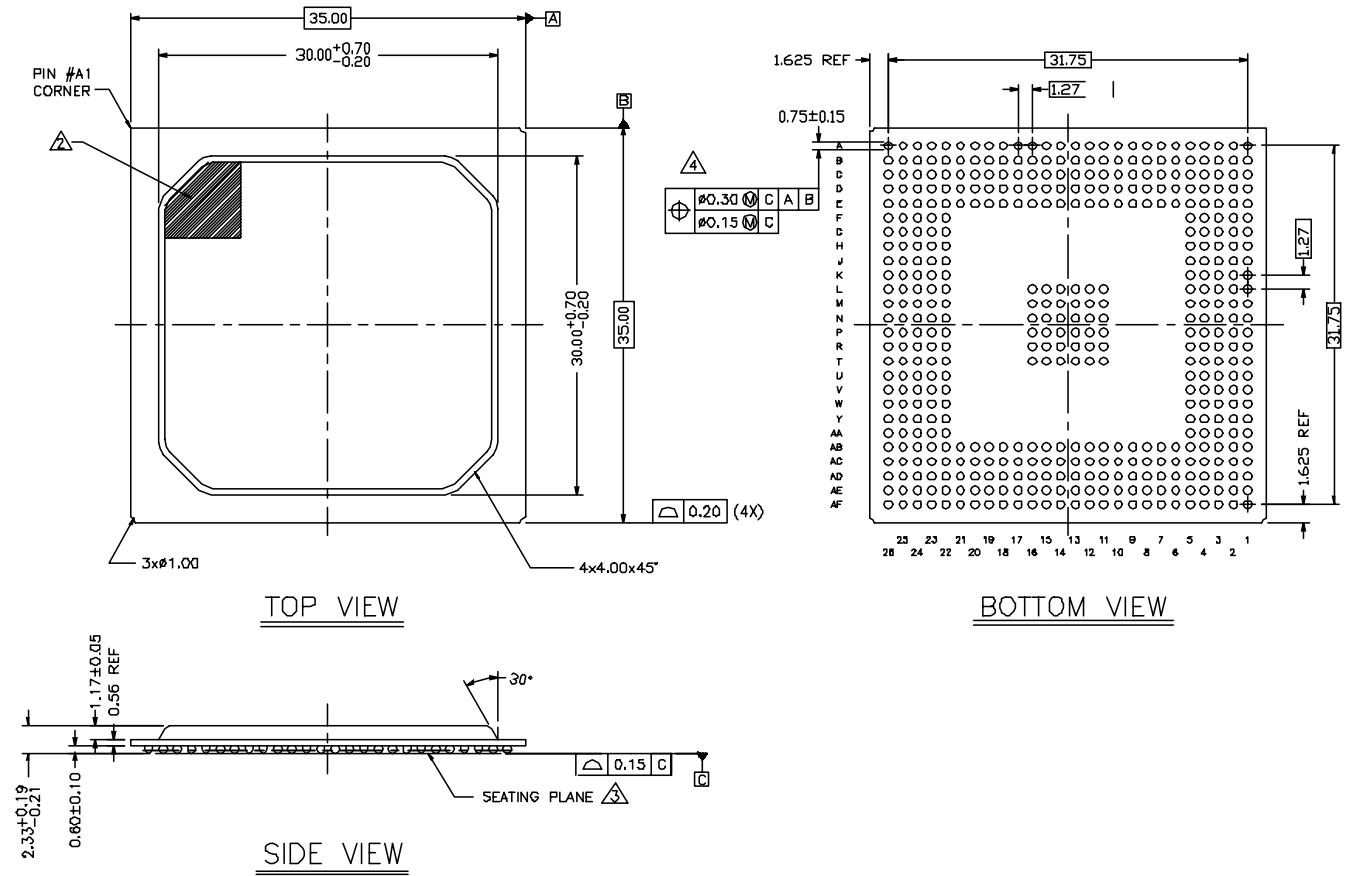

Figure 15: 456 PBGA Mechanical Drawing

Contact Information

Telephone: 408 990 4000 (US)
 416 497 8884 (Canada)
 44 1932 57 9011 (Europe)
 49 89 930 86 170 (Germany)
 852 8106 9091 (Asia)
 81 45 470 5525 (Japan)

E-mail: info@quicklogic.com

Support: support@quicklogic.com

Web site: <http://www.quicklogic.com/>

Revision History

Table 15: Revision History

Revision	Date	Comments
A	not avail.	First release.
B	not avail.	
C	not avail.	
D	not avail.	
E	not avail.	
F	not avail.	
G	May 2000	Update of AC/DC Specs and reformat
H	May 2002	Added Kfactor, Power-up, JTAG and mechanical drawing information. Reformatted.

Copyright Information

Copyright © 2002 QuickLogic Corporation.

All Rights Reserved.

The information contained in this product brief, and the accompanying software programs are protected by copyright. All rights are reserved by QuickLogic Corporation. QuickLogic Corporation reserves the right to make periodic modifications of this product without obligation to notify any person or entity of such revision. Copying, duplicating, selling, or otherwise distributing any part of this product without the prior written consent of an authorized representative of QuickLogic is prohibited.

QuickLogic, pASIC, and ViaLink are registered trademarks, and SpDE and QuickWorks are trademarks of QuickLogic Corporation.

Verilog is a registered trademark of Cadence Design Systems, Inc.