

PRELIMINARY DATA SHEET

SKY42068: 400-1000 MHz High Dynamic Range Active Mixer

Applications

- GSM/EDGE/CDMA/AMPS/TETRA
- Mobile radio systems
- Industrial, Scientific, Medical (ISM) band applications

Features

- High, 3rd Order Input Intercept Point (IIP3) mixer
- Wideband RF input frequency range (400 to 1000 MHz)
- CMOS-compatible control interface
- +5 V supply operation
- -40 °C to +85 °C operating range
- Supports frequency hopping applications
- QFN (20-pin, 5 x 5 mm) Pb-free package (MSL3, 260 °C per JEDEC J-STD-020)

Description

The SKY42068 is an integrated, high-dynamic range low-noise receiver down converter. It includes a double-balanced active mixer, Local Oscillator (LO) amplifiers, and dual LO inputs selected by an external switch interface. The LO switch function is managed using an externally controlled CMOS-compatible interface.

The 20-pin Quad Flat No-Lead (QFN) device package and pinout are shown in Figure 1. Figure 2 shows a functional block diagram for the SKY42068.



Skyworks offers lead (Pb)-free, RoHS (Restriction of Hazardous Substances) compliant packaging.

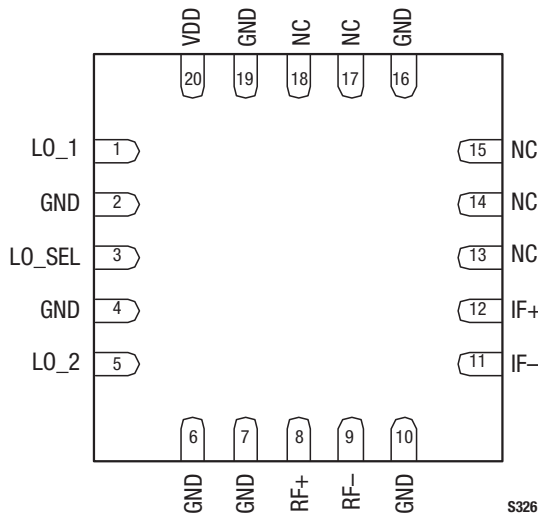

Figure 1. SKY42068 Pinout – 20-Pin QFN (Top View)

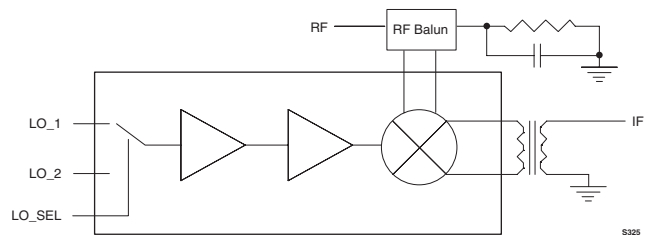

Figure 2. SKY42068 Block Diagram

Table 1. SKY42068 Signal Descriptions

Pin #	Name	Description	Pin #	Name	Description
1	LO_1	Local oscillator 1 input	11	IF-	Negative IF output
2	GND	Ground	12	IF+	Positive IF output
3	LO_SEL	Select control for LO_1 and LO_2	13	NC	No connection
4	GND	Ground	14	NC	No connection
5	LO_2	Local oscillator 2 input	15	NC	No connection
6	GND	Ground	16	GND	Ground
7	GND	Ground	17	NC	No connection
8	RF+	Positive RF input	18	NC	No connection
9	RF-	Negative RF input	19	GND	Ground
10	GND	Ground	20	VDD	Supply voltage

Table 2. SKY42068 Absolute Maximum Ratings

Parameter	Symbol	Minimum	Typical	Maximum	Units
Positive DC power supply	VDD			5.5	V
Power dissipation	P _D			1.7	W
Input power	P _{IN}			22	dBm
Thermal resistance	R _{TH}		25		°C/W
Operating case temperature	T _{OPR}	-40		+85	°C
Storage case temperature	T _{STG}	-40		+125	°C

Note: Exposure to maximum rating conditions for extended periods may reduce device reliability. There is no damage to device with only one parameter set at the limit and all other parameters set at or below their nominal value.

Table 3. SKY42068 Recommended Operating Conditions

Parameter	Symbol	Minimum	Typical	Maximum	Units
Positive DC supply voltage	VDD	4.75	5.0	5.25	V
Power dissipation	P _D		1.1		W
Operating case temperature	T _{OPR}	-40		+85	°C

Functional Description

The SKY42068 consists of a high dynamic active mixer, LO amplifiers, and a selectable LO input. The SKY42068 was specifically designed to meet the needs of high performance receivers.

The mixer shares two independent LO signals, LO_1 and LO_2, that are selected using a common CMOS-compatible control signal. With this ability, the device can be used in applications where frequency hopping is required.

Electrical and Mechanical Specifications

Signal pin assignments and functional pin descriptions are described in Table 1. The absolute maximum ratings of the SKY42068 are provided in Table 2. The recommended operating conditions are specified in Table 3 and electrical specifications are provided in Table 4.

Table 4. SKY42068 Electrical Specifications**(voltage supply = +5 V, T_c = +25 °C, LO = 0 dBm, RF frequency = 900 MHz, IF frequency = 71 MHz, unless otherwise noted)**

Parameter	Symbol	Test Condition	Min	Typical	Max	Units
RF						
RF input frequency			400		1000	MHz
RF input VSWR (Note 1)				1.5:1	2.0:1	
Mixer (Note 2)						
Conversion gain				2.5		dB
Single side band noise figure				9.5		dB
Input IP3		1 MHz tone spacing		36		dBm
RF to IF leakage (Note 3)				-40		dBm
LO to IF leakage				-25		dBm
Input -1 dB compression point			+14	+17		dBm
2x2 product suppression (Note 4)				-70		dBc
Local Oscillator						
LO input frequency (Note 5)			450		1200	MHz
LO input VSWR (Note 1)				1.5:1	2.0:1	
LO level input			-5	0	+5	dBm
L01 to L02 isolation			40			dB
Intermediate Frequency						
IF output frequency			50		250	MHz
IF output VSWR (Note 1)		IF = 50 MHz to 200 MHz		1.5:1	2.0:1	

Note 1: In a 50 Ω system obtained with external matching components on input/output ports.

Note 2: Include RF balun and IF transformer losses.

Note 3: Measured with an RF input power of -10 dBm.

Note 4: Measured with an RF input power of -16 dBm.

Note 5: Use high side LO injection for RF frequencies below 500 MHz.

Evaluation Board Description

The SKY42068 Evaluation Board is used to test the SKY42068 mixer performance. The SKY42068 Evaluation Board schematic diagram is shown in Figure 3. Figure 4 displays the Evaluation Board layout. The Bill of Materials (BOM) is provided in Table 5.

Circuit Design Configurations

The following design considerations are general in nature and must be followed regardless of final use or configuration:

1. Paths to ground should be made as short as possible.
2. The ground pad of the SKY42068 mixer has special electrical and thermal grounding requirements. This pad is the main thermal conduit for heat dissipation. Since the circuit board acts as the heat sink, it must shunt as much heat as possible from the mixer. As such, design the connection to the ground pad to dissipate the maximum wattage produced to the circuit board. Multiple vias to the grounding layer are required.

3. Two external output bypass capacitors are required on the VDD pin. The values of these capacitors will change with respect to the desired RF frequency. One capacitor should be used for low frequency bypassing and the other capacitor for high frequency bypassing. Special attention should be given so that the smaller value capacitor does not go into self-resonance at the desired RF frequency.
4. The RF input must be driven differentially. A 1:1 impedance ratio balun is recommended with a center tap on the secondary side that is a DC path to ground.

Mixer Testing Procedure

Use the following procedure to set up the SKY42068 Evaluation Board for mixer testing. Refer to Figure 5 for guidance:

1. Connect the SKY42068 Evaluation Board (J1) to a +5 VDC power supply using insulated supply cables. If available, enable the current limiting function of the power supply to 250 mA.

2. Connect a signal generator to the LO1 input port (J3). Set the generator to the desired LO frequency at a power level of 0 dBm, but **do not enable**.
3. Connect a signal generator to the mixer RF input port (J7). Set the generator to the desired RF frequency at a power level of 0 dBm, but **do not enable**.
4. Connect a spectrum analyzer to the IF output port of the mixer (J6).
5. Enable the power supply.
6. Enable the LO signal.
7. Enable the RF signal and take measurements.
8. If LO2 is desired, connect the LO signal generator to the LO2 input port (J8) and pull the LO_SEL jumper (J2).

Package Dimensions

Figure 6 shows the package dimensions for the 20-pin QFN and Figure 7 provides the tape and reel dimensions.

Package and Handling Information

Since the device package is sensitive to moisture absorption, it is baked and vacuum packed before shipping. Instructions on the shipping container label regarding exposure to moisture after the container seal is broken must be followed. Otherwise, problems related to moisture absorption may occur when the part is subjected to high temperature during solder assembly.

The SKY42068 is rated to Moisture Sensitivity Level 3 (MSL3) at 260 °C. It can be used for lead or lead-free soldering.

Care must be taken when attaching this product, whether it is done manually or in a production solder reflow environment. Production quantities of this product are shipped in a standard tape and reel format. For packaging details, refer to the Skyworks Application Note, *Tape and Reel*, document number 101568.

Electrostatic Discharge (ESD) Sensitivity

The SKY42068 is a static-sensitive electronic device. Do not operate or store near strong electrostatic fields. Take proper ESD precautions.

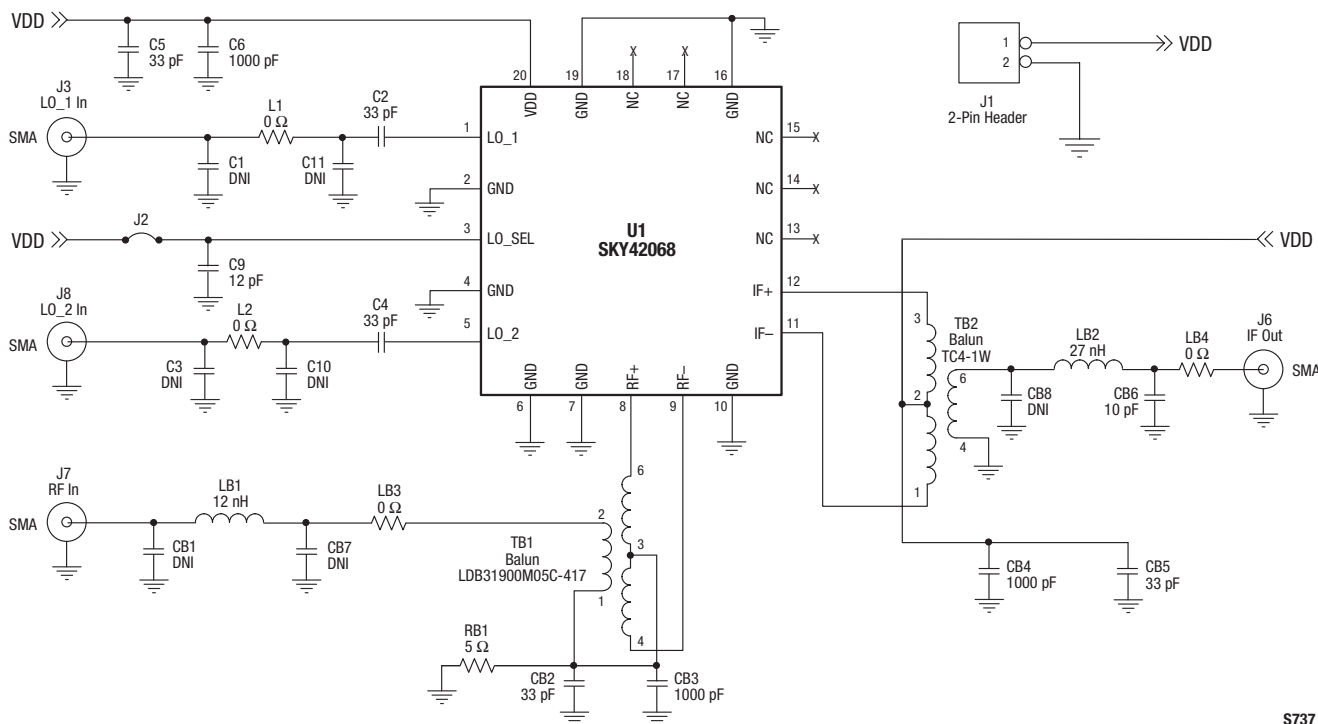
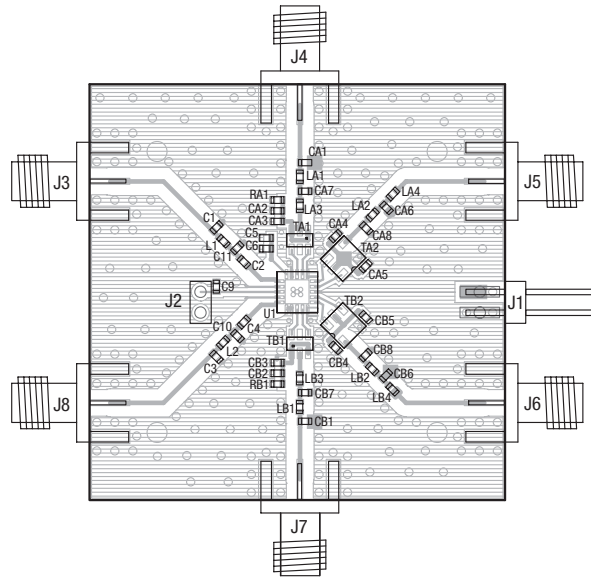
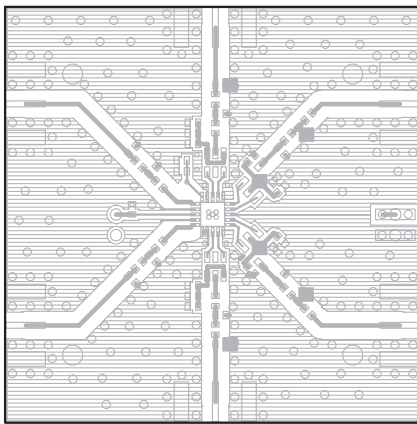

Figure 3. SKY42068 Evaluation Board Schematic (900 MHz)

S737



Component Placement



Top Layer



Layer 2

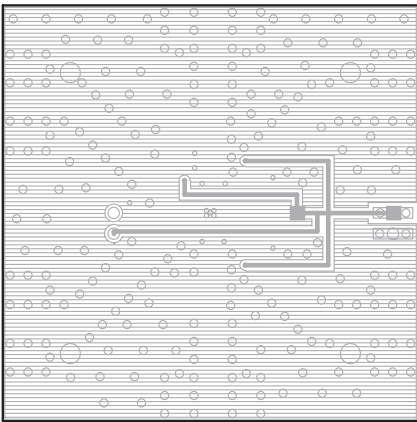

Layer 3



Bottom Layer

S739

Figure 4. SKY42068 Evaluation Board Assembly Diagram (900 MHz)

Table 5. SKY42068 Evaluation Board Component Values (900 MHz)

Reference Designator	Quantity	Value	Manufacturer	Part Number
C1, C3, C10, C11, CA1, CA2, CA3, CA4, CA5, CA6, CA7, CA8, CB1, CB7, CB8, J4, J5, LA1, LA2, LA3, LA4, RA1, TA1, TA2	24	DNI		
C2, C4, C5, CB2, CB5	5	33 pF		
C6, CB3, CB4	3	1000 pF		
C9	1	12 pF		
CB6	1	10 pF		
J1	1	Two-pin header connector		
J2	1	Jumper		
J3, J6, J7, J8	4	SMA connector		
L1, L2, LB3, LB4	4	0 Ω		
LB1	1	12 nH		
LB2	1	27 nH		
RB1	1	5 Ω		
TB1	1	1:1 (800-1000 MHz)	Murata	LDB31900M05C-417
TB2	1	4:1 (3-800 MHz)	Mini-Circuits	TC4-1W
U1	1	–	Skyworks	SKY42068-11

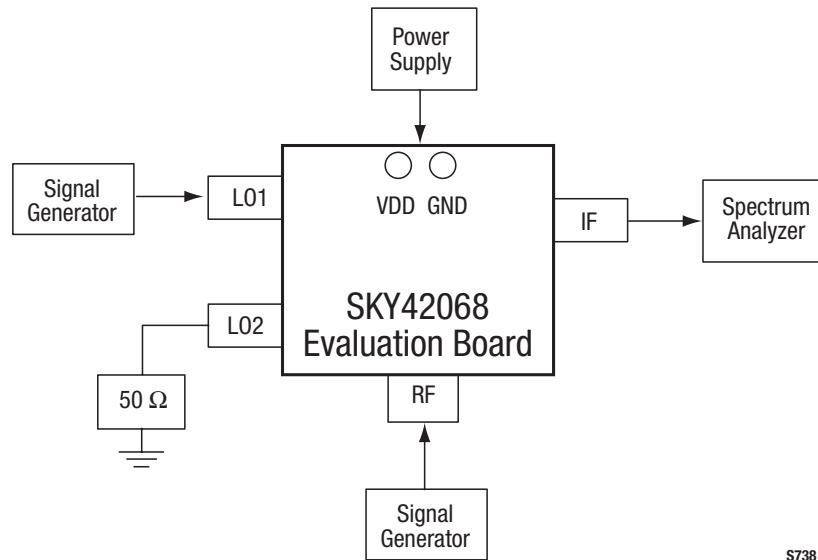

S738

Figure 5. SKY42068 Evaluation Board Mixer Testing Configuration

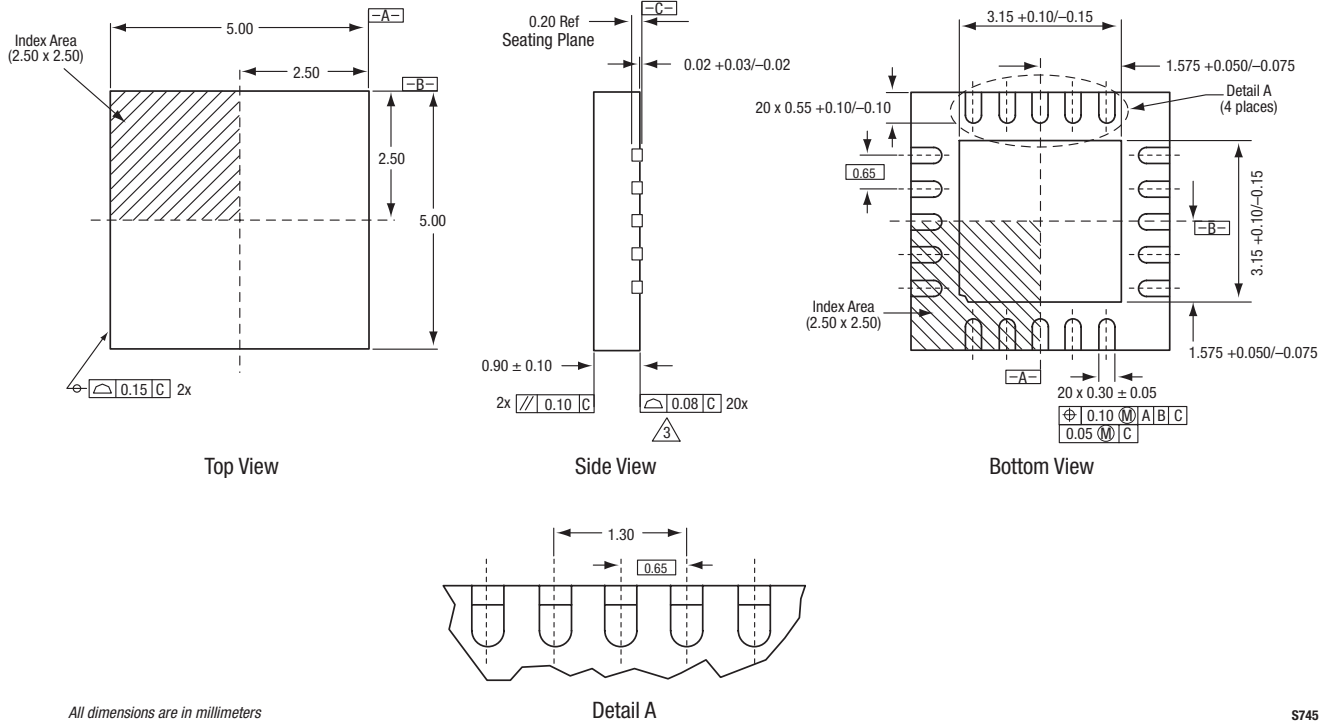

S745

Figure 6. SKY42068 20-Pin QFN Package Dimensions

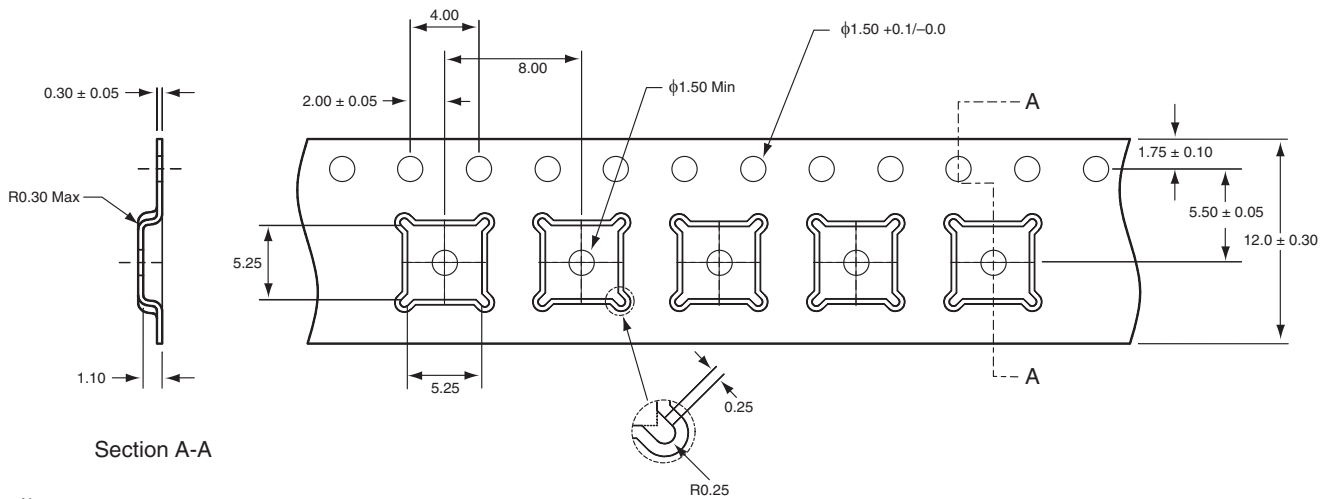

Notes:

1. Carrier tape: black conductive polycarbonate or polystyrene.
2. Cover tape material: transparent conductive PSA.
3. All dimensions are in millimeters.

S379

Figure 7. SKY42068 20-Pin QFN Tape and Reel Dimensions

Ordering Information

Model Name	Manufacturing Part Number	Evaluation Kit Part Number
SKY42068 Active Mixer	SKY42068-11 (Pb-free package)	TW12-D761

Copyright © 2006, Skyworks Solutions, Inc. All Rights Reserved.

Information in this document is provided in connection with Skyworks Solutions, Inc. ("Skyworks") products or services. These materials, including the information contained herein, are provided by Skyworks as a service to its customers and may be used for informational purposes only by the customer. Skyworks assumes no responsibility for errors or omissions in these materials or the information contained herein. Skyworks may change its documentation, products, services, specifications or product descriptions at any time, without notice. Skyworks makes no commitment to update the materials or information and shall have no responsibility whatsoever for conflicts, incompatibilities, or other difficulties arising from any future changes.

No license, whether express, implied, by estoppel or otherwise, is granted to any intellectual property rights by this document. Skyworks assumes no liability for any materials, products or information provided hereunder, including the sale, distribution, reproduction or use of Skyworks products, information or materials, except as may be provided in Skyworks Terms and Conditions of Sale.

THE MATERIALS, PRODUCTS AND INFORMATION ARE PROVIDED "AS IS" WITHOUT WARRANTY OF ANY KIND, WHETHER EXPRESS, IMPLIED, STATUTORY, OR OTHERWISE, INCLUDING FITNESS FOR A PARTICULAR PURPOSE OR USE, MERCHANTABILITY, PERFORMANCE, QUALITY OR NON-INFRINGEMENT OF ANY INTELLECTUAL PROPERTY RIGHT; ALL SUCH WARRANTIES ARE HEREBY EXPRESSLY DISCLAIMED. SKYWORKS DOES NOT WARRANT THE ACCURACY OR COMPLETENESS OF THE INFORMATION, TEXT, GRAPHICS OR OTHER ITEMS CONTAINED WITHIN THESE MATERIALS. SKYWORKS SHALL NOT BE LIABLE FOR ANY DAMAGES, INCLUDING BUT NOT LIMITED TO ANY SPECIAL, INDIRECT, INCIDENTAL, STATUTORY, OR CONSEQUENTIAL DAMAGES, INCLUDING WITHOUT LIMITATION, LOST REVENUES OR LOST PROFITS THAT MAY RESULT FROM THE USE OF THE MATERIALS OR INFORMATION, WHETHER OR NOT THE RECIPIENT OF MATERIALS HAS BEEN ADVISED OF THE POSSIBILITY OF SUCH DAMAGE.

Skyworks products are not intended for use in medical, lifesaving or life-sustaining applications, or other equipment in which the failure of the Skyworks products could lead to personal injury, death, physical or environmental damage. Skyworks customers using or selling Skyworks products for use in such applications do so at their own risk and agree to fully indemnify Skyworks for any damages resulting from such improper use or sale.

Customers are responsible for their products and applications using Skyworks products, which may deviate from published specifications as a result of design defects, errors, or operation of products outside of published parameters or design specifications. Customers should include design and operating safeguards to minimize these and other risks. Skyworks assumes no liability for applications assistance, customer product design, or damage to any equipment resulting from the use of Skyworks products outside of stated published specifications or parameters.

Skyworks, the Skyworks symbol, and "Breakthrough Simplicity" are trademarks or registered trademarks of Skyworks Solutions, Inc., in the United States and other countries. Third-party brands and names are for identification purposes only, and are the property of their respective owners. Additional information, including relevant terms and conditions, posted at www.skyworksinc.com, are incorporated by reference.