

Modular DAA with 2/4 Wire Convertor

Description

The XE0002D is a compact DAA module designed for applications requiring voice, data or fax transfer. It complies with FCC Part 68 rules for direct connection to the public switched telephone network and also supports leased line applications.

The XE0002D provides a complete telephone interface. It includes the 2/4 wire convertor to separate transmit and receive signals, ring detection, integral switch hook and telephone line transformer. All of this circuitry is integrated into a module requiring only 1.25 inches of board space.

Features:

- Small Size: just 1.25 inches by 1.0 inches by 0.32 inches high
- FCC Part 68 Compliant
- User selectable 2-4 wire convertor
- Active Low Ring Detection
- Integral Switch Hook
- Supports V.32 Data Transfer
- Supports both dial-up and leased line applications
- Extended Operating Temperature Range (-40C to +85C) available

XE0002D Block Diagram

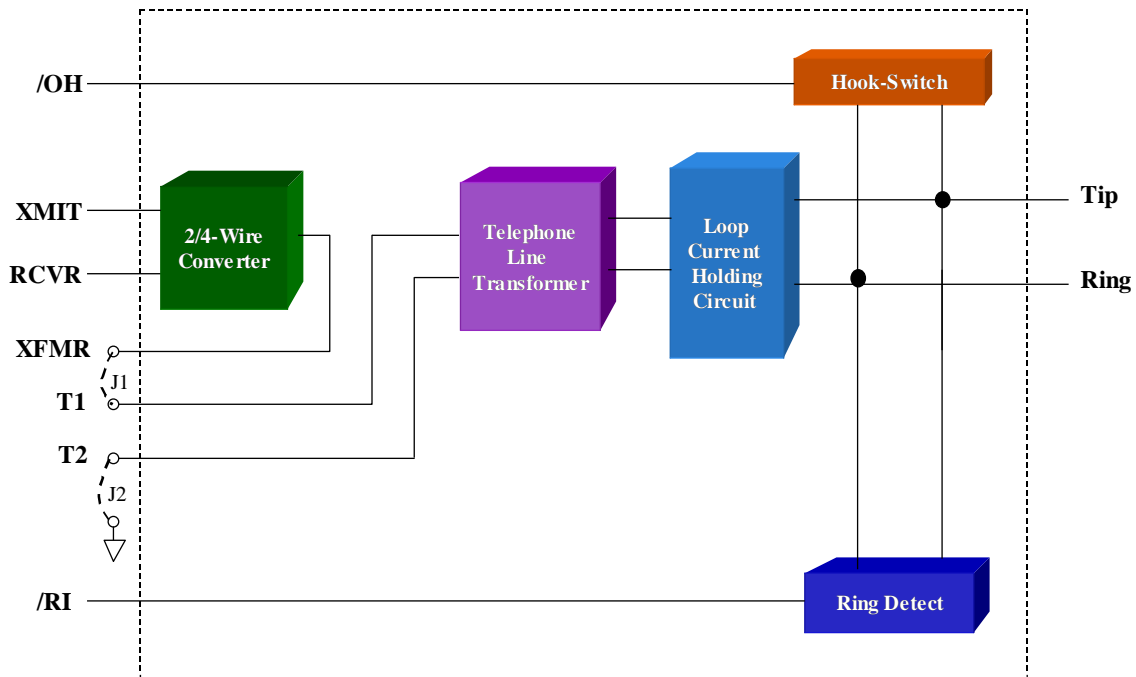

Jumpers J1 and J2 must be installed to connect the 2 to 4 wire convertor.

XE0002D Mechanical Specifications

Dim	Inches		Millimeters	
	Min	Max	Min	Max
A	1.235	1.265	31.37	32.13
B	0.985	1.015	25.02	25.78
C	0.490	0.510	12.45	12.95
D	0.890	0.910	22.61	23.11
E	0.890	0.910	22.61	23.11
F	0.125	-	3.18	-
G	0.040	0.060	1.02	1.52
H	0.165	0.185	4.19	4.70
J	0.090	0.110	2.29	2.79
K	0.020	0.025	0.51	0.64

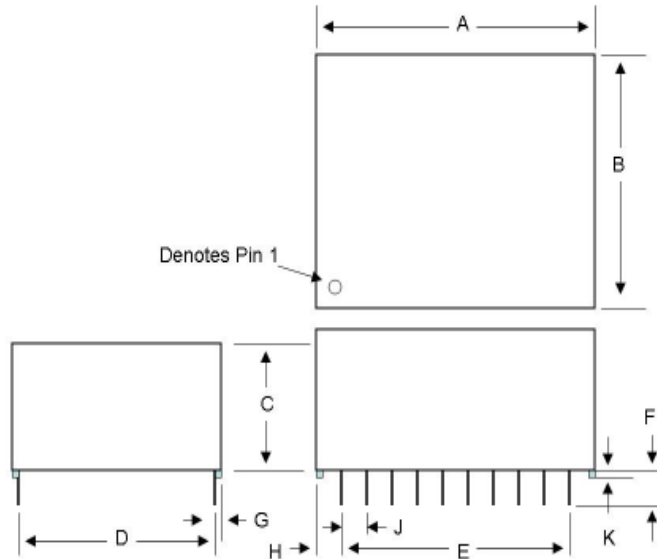

XE0002D Pin Configuration

VDD	● 1		20 ●	TIP
VCC	● 2			
/RI	● 3	(Top View)		
RCVR	● 4		17 ●	RING
XMIT	● 5			
XFMR	● 6			
T1	● 7		14 ●	N/C
OH	● 8		13 ●	N/C
Gnd	● 9		12 ●	N/C
T2	● 10		11 ●	N/C

XE0002D Pin Descriptions

Pin	Name	Description
1	VDD	VDD supplies -5 Volt power to the XE0002D's 2 to 4 wire converter.
2	VCC	VCC supplies +5 Volts power to the XE0002D
3	/RI	Ring Indicate, output, active low, TTL. /RI indicates the XE0002D is receiving a ring signal. /RI remains low for the duration of each ring.
4	RCVR	RCVR acts as the analog output from the XE0002D's 2 to 4 wire converter. Signals pass from the telephone line to the host via RCVR
5	XMIT	XMIT provides the analog input to the XE0002D's 2 to 4 wire converter. Signals placed on XMIT are sent out onto the telephone line.
6	XFMR	XFMR is provided to connect the internal 2 to 4 wire converter to the telephone line transformer. A jumper is required from XFMR to T1 whenever the 2 to 4 wire circuit is required.
7	T1	T1 is one of two direct connections to the internal telephone line transformer. T1 must be connected to the XE0002D XFMR lead to use the internal 2 to 4 wire converter. If the 2 to 4 wire converter is not required, Signals for the telephone line can be passed across T1 and T2.
8	OH	Hookswitch relay control. A high on OH closes the internal relay and connects the equipment to the telephone line.
9	Gnd	Gnd provides the ground reference connection to the XE0002D.
10	T2	T2 is one of two direct connections to the internal telephone line transformer. T2 must be connected to Ground to use the internal 2 to 4 wire converter. If the 2 to 4 wire converter is not required, Signals for the telephone line can be passed across T1 and T2.
11-14		No Connection
17	Ring	Ring is one wire of the two-wire telephone line connection (RJ11 Pin 4). FCC Part 68 Rules require a 1500 volt isolation barrier between the telephone line and all other circuits. This isolation must be preserved throughout the system. Xecom recommends 0.100 inch spacing between traces connected to Ring and all other conductors to preserve this isolation
20	Tip	Tip is one wire of the two-wire telephone line connection (RJ11 Pin 3). The telephone company places a DC "Battery" voltage across Tip and Ring on all public switched telephone lines. The XE0002D accept this line battery voltage without regard to its polarity.

XE0002D Electrical Specifications (VCC = 5V + 10%, Ta = 0 to 70C)

Parameter	Conditions	Min	Typ	Max	Units
Power Supply Current	VCC		10		mA
	VDD		4		mA
Transmit Insertion loss	600 Ohm Impedance, 1000 Hz		0		dB
Receive Insertion loss	600 Ohm Impedance, 1000 Hz		0		dB
Line Matching Resistor (Rm)	for 600 ohm telephone line		340		ohms
Line Impedance	At 1000 Hz, Rm equal to 340 ohms without internal 2/4 wire convertor	540	600	660	Ohms
Transhybrid Loss	Attenuation between transmitter input and receiver output at 1KHz with 600 ohm line termination	10	18		dB
Transmit Input Impedance	At XMIT, 1800 Hz	8	10	12	Kohm
Receive Output Impedance	At RCVR, 1800 Hz		10	100	ohms
Ring Detect Sensitivity	Min. AC voltage between Tip & Ring Type B ringer	38			Vrms
Ring Indicate Output	Ring Voltage present on Tip and Ring		0.2	0.5	Volts
Hook Switch Control Voltage	ON: (off-hook)	4.0			Volts
	OFF: (on-hook)			0.8	Volts
Hook Switch Control Current	Off-Hook			0.5	mA
Telephone Line Loop Current	Off-Hook	20		100	mA

XE0002D Absolute Maximum Ratings

Storage Temperature	-25C to +85C
Operating Temperature Range	0C to +70C
Maximum Lead Temperature (soldering 2 seconds per wave)	260 ^o C

XE0002D Typical Connection Diagram with Internal 2/4 Wire Converter

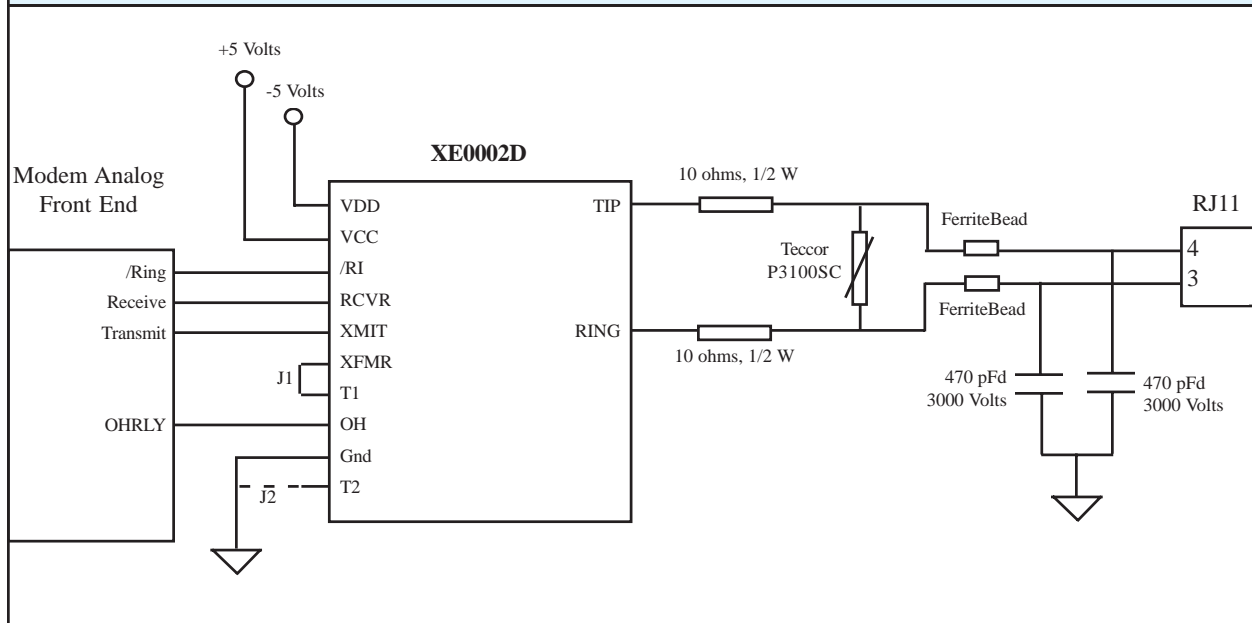

XE0002D Typical Connection Diagram without Internal 2/4 Wire Converter

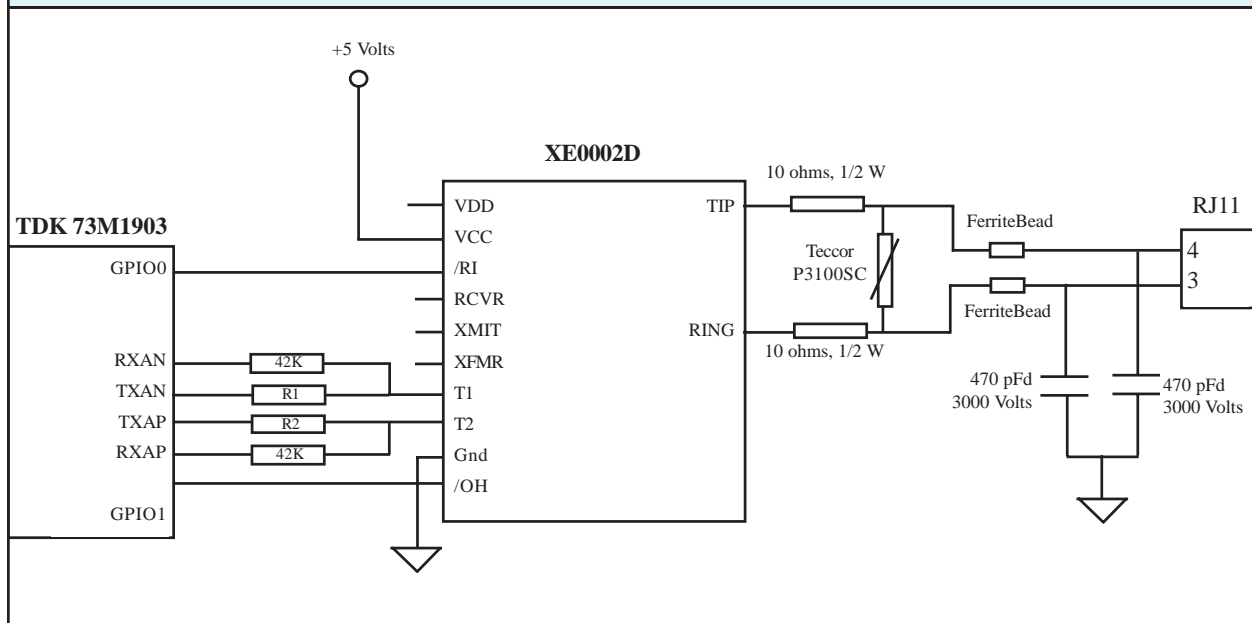

Note:

R1 and R2 each equal one half of the ideal line matching impedance, 170 ohms.

XE0002D FCC Instructions

When developing a product to be connected to the telephone line, it is necessary to use a circuit described as a Data Access Arrangement (DAA) which is approved by the appropriate governmental agency. In the US, for example, this agency is the Federal Communications Commission (FCC), while in Canada it is the Department of Communications (DOC). These agencies test and approve the product to ensure that it meets their specifications, thereby protecting the telephone system from damage and protecting the user from high voltage transients (such as lightning strikes) which may come down the telephone line.

The XE0002D has been designed to meet all FCC Part 68 requirements for hazardous voltage, surge protection and leakage current. If the system developed transmits data, or DTMF tones on the telephone line, the user must certify that the signals transmitted meet basic FCC requirements for maximum transmission levels, out of band energy and billing delay. Full details may be obtained from the FCC under Part 68 of the FCC Rules and Regulations, or in Title 47 of the Code of Federal Regulations, however the basic requirements are as follows:

1. Maximum Transmit Level

For the normal “permissive” (standard) telephone line, equipment which transmits data (such as a modem) must not exceed a transmission level of -9 dBm.

2. Out of Band Energy

Data equipment must not transmit “out of band” energy on the telephone line which exceeds the following limits:

Frequency		Range	Max. Power
200Hz	to	3990Hz	-9 dBm
3990Hz	to	4005Hz	-27 dBm
4005Hz	to	16kHz	-16 dBm
8kHz	to	94kHz	-47 dBm
86kHz	to	270kHz	-46 dBm
270kHz	to	6MHz	-6 dBm

3. DTMF Transmission Level

If the system is capable of DTMF dialing, the maximum DTMF transmission level must be less than 0 dBm averaged over a 3 second interval.

4. Billing Delay

A delay of 2 seconds or greater is required after the time the XE0002D is taken “off hook” and before any information is transmitted. This is required to ensure that billing information may be exchanged between telephone company central offices without interference.

The user of the XE0002D must certify to the FCC that the final system meets the requirements of Part 68 which include the criteria above as well as the high voltage protection provided by the XE0002D. This is generally accomplished through an independent testing lab which tests the System and submits the proper paperwork to the FCC for approval. Since the XE0002D already complies with FCC Part 68 rules, this is a relatively simple process.

Terms of Sale

Devices sold by XECOM are covered by the warranty provisions appearing in its Terms of Sale only. XECOM makes no warranty, express, statutory, implied, or by description regarding the information set forth herein, or regarding the freedom of the described devices from patent infringement. XECOM makes no warranty of merchantability or fitness for any purposes. XECOM reserves the right to discontinue production and change specifications and prices at any time and without notice. This product is intended for use in normal commercial applications. Applications requiring extended temperature range, unusual environmental requirements, or high reliability applications, such as military, medical life-support or life-sustaining equipment, are specifically not recommended without additional processing and authorization by XECOM for such application.

Xecom assumes no responsibility for the use of any circuitry other than circuitry embodied in a Xecom product. No other circuits, patents, or licenses are implied.

Life Support Policy

Xecom's products are not authorized for use as Critical Components in Life Support Devices or Systems.

Life Support Devices or Systems are devices or systems which, (a) are intended for surgical implant into the body, or (b) support or sustain life, and whose failure to perform, when properly used in accordance with instructions provided in the labeling, can be reasonably expected to result in significant injury to the user.

A **Critical Component** is any component of a life support device or system whose failure to perform can be reasonably expected to cause failure of the life support device or system, or to affect its safety or effectiveness.

Copyright, Xecom © 2005

While Xecom, Inc. has made every effort to ensure that the information presented here is accurate, Xecom will not be liable for any damages arising from errors or omission of fact. Xecom reserves the right to modify specifications and/or prices without notice. Product mentioned herein are used for identification purposes only and may be trademarks and/or registered trademarks of their respective companies.

The logo for Xecom, featuring the word "xecom" in a bold, lowercase, sans-serif font with a registered trademark symbol (®) to the upper right. The text is white and set against a black rectangular background.

Xecom Incorporated
374 Turquoise Street, Milpitas, CA 95035
Ph:408-942-2200 Fax:408-942-1346
Email: info@xecom.com
www.xecom.com